

Elite Gourmet

2.1 QT. OIL-FREE AIR FRYER

MODEL: EAF-0201 (A~Z)

INSTRUCTION MANUAL

Before operating your new appliance, please read all instructions carefully and keep for future reference.



Intertek



Questions? Elite's customer service team is ready to help.
For more Elite products, visit us at shopelitegourmet.com.
Recipes are included in this manual.



TABLE OF CONTENTS

IMPORTANT SAFEGUARDS	2
SHORT CORD PURPOSE	4
POLARIZED PLUG	4
INTRODUCTION	4
PARTS IDENTIFICATION	5
CONTROL PANEL	6
BEFORE FIRST USE	6
HOW TO USE	7
CLEANING AND MAINTENANCE	9
COOKING TIME CHART	9
HINTS AND TIPS	11
AIR FRYER RECIPES	12
TROUBLESHOOTING GUIDE	18
WARRANTY POLICY	19
RETURN INSTRUCTIONS	20

IMPORTANT SAFEGUARDS

The Elite Brand takes consumer safety very seriously. Products are designed and manufactured with our valued consumers' safety in mind. Additionally, we ask that you exercise a level of caution when using any electrical appliance by following all instructions and important safeguards.

READ ALL INSTRUCTIONS BEFORE USE AND SAVE FOR FUTURE REFERENCE

WARNING: When using electrical appliances, basic safety precautions should always be followed as below:

1. Read all instructions before using your Elite Platinum Air Fryer.
2. Never immerse the power cord, plug or housing in water or under the tap.
3. Make sure no liquid enters the appliance to prevent electric shock or short-circuit.
4. Do not cover the air inlet and outlet of the appliance during operation.
5. Always place foods to be cooked on the rack, foods should never come into direct contact with the heating elements.
6. Never fill the pan with oil as this may cause a fire hazard and damage to the appliance.
7. Never touch the inside of the appliance during operation.
8. Make sure that your output voltage corresponds to the voltage stated on the rating label of the appliance.
9. It is recommended to regularly inspect the appliance to avoid a hazard. Do not operate any appliance with a damaged cord or plug or after the appliance malfunctions or has been damaged in any manner. Return appliance to the nearest authorized service facility for examination, repair, or adjustment.
10. If the supply cord is damaged, it must be replaced by a special cord or assembly available from the manufacture or its service agent.
11. Never attempt to repair the appliance yourself, otherwise the warranty becomes invalid.
12. This appliance is not intended for use by persons (including children) with reduced physical, sensory or mental capabilities, or lack of experience and knowledge, unless they have been given supervision or instruction concerning use of the appliance by a person responsible for their safety.
13. Close supervision is necessary when appliance is used near children.
14. NEVER ALLOW A CHILD TO USE THIS PRODUCT.
15. DO NOT let the power cord hang over the edge of the table or work-top, and keep it away from any hot surfaces.
16. Do not plug in the appliance or operate the control panel with wet hands.
17. Do not place or use the appliance on or near combustible materials, such as a tablecloth, curtains or wallpaper.
18. Only connect the appliance to a grounded wall socket. Always make sure that the plug is inserted into the wall socket properly.
19. Never connect this appliance to an external timer switch in order to avoid a hazardous situation.
20. Never leave appliance unattended.
21. Appliance surfaces may become hot during use.

IMPORTANT SAFEGUARDS (cont.)

22. The appliance should be placed on a horizontal and stable surface when using. Do not place on plastics, board or any other easy-wear surface.
23. Do not place the appliance against wall or other appliances, leave around 4 inches of space from nearby objects. Do not place anything on the top of appliance.
24. Do not use the appliance beyond the specification of this manual.
25. During operation, hot steam will exhaust through the hind side air outlet. Keep your hands and face at a safe distance from the steam and the air outlet openings. Also be careful of hot steam and air when you remove the pan from the appliance.
26. If food burns and dark smoke releases from the air outlet, unplug immediately and wait for smoke release to stop, then clean the food and oil from the pan and rack.
27. After use, turn off power to the appliance then unplug from the wall outlet.
28. Do not use any accessories that have not been provided with the appliance.
29. Unplug the appliance from outlet when it is not in use or before cleaning. Allow it to cool down first before cleaning.
30. This appliance is intended to be used indoors. Do not use outdoors.
31. Clean and wipe and dry the pan and the rack before placing food inside.
32. Always unplug the appliance when not in use.
33. If the appliance is of the grounded type, the extension cord should be a grounded cord.
34. To ensure continued protection against risk of electric shock, connect to properly grounded outlets only.
35. Some countertop and table surfaces, such as Corian®, wood and / or laminates, are not designed to withstand prolonged heat generated by certain appliances. It is recommended by countertop manufacturers and Maxi-Matic that a hot pad or trivet be placed under your appliance to prevent possible damage to the surface.

**SAVE THESE INSTRUCTIONS.
THIS PRODUCT IS FOR
HOUSEHOLD USE ONLY.**

SHORT CORD PURPOSE

Longer power-supply cords or extension cords may be used if care is exercised in their use.

If an extension cord is used: (1) the marked electrical rating of the extension cord should be at least as great as the electrical rating of the product; (2) the extension cord should be arranged so that it will not drape over the countertop or tabletop where it can unintentionally be pulled on or tripped over by children or pets.

POLARIZED PLUG

If this appliance is equipped with a *polarized plug* (one blade is wider than the other), please follow the below instructions:

To reduce the risk of electrical shock, this plug is intended to fit into a polarized outlet only one way. If you are unable to fit the plug into the electrical outlet, try reversing the plug. If the plug still does not fit, contact a qualified electrician. Never use the plug with an extension cord unless the plug can be fully inserted into the extension cord. Do not alter the plug of the product or any extension cord being used with this product. Do not attempt to defeat the safety purpose of the polarized plug.

INTRODUCTION

Thank you for purchasing the Elite Gourmet Air Fryer. Your new Air Fryer has a variety of functions to handle a wide array of cooking tasks. With its easy to use temperature and timer knobs, you can fry, cook, or even bake your favorite meals and snacks with ease! Best of all you will be cooking healthier without the addition of oil. Not only can you cook foods without the mess of oil but you can cook faster which saves you time and energy. Unlike most conventional deep fryers, the Air Fryer's unique vapor system combined with circulating hot air will automatically make foods crispier and of course healthier without oil. We hope you enjoy your new Elite Gourmet Air Fryer and start cooking healthier today!



NOTE:

A short power cord is provided to reduce the risk of personal injury resulting from becoming entangled in or tripping over a long cord.

PARTS IDENTIFICATION

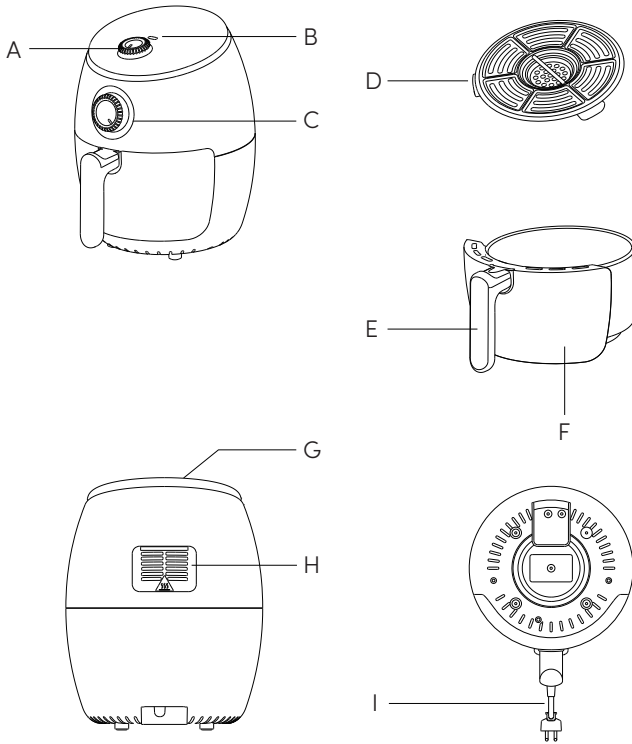

- A. Temperature Knob
- B. Power Indicator
- C. Timer Knob
- D. Frying Rack
- E. Handle
- F. Pull-Out Drawer Pan
- G. Air Inlet
- H. Air Outlet
- I. Power Cord



NOTE:

The Frying Rack consists of a non-stick surface. To avoid scratching the non-stick surface, please use wooden or heat-proof silicone utensils.

CONTROL PANEL

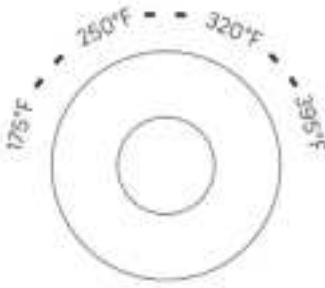

TEMPERATURE CONTROL KNOB

Use this knob to set the temperature between 175°F up to 395°F.

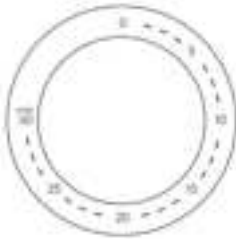

TIMER CONTROL KNOB

Use this knob to set the desired time setting between 1-minute and 30-minutes. The timer knob **MUST** be set in order for the appliance to begin heating

PFOA-FREE NONSTICK COATING

The cooking surface is coated with a PFOA-Free nonstick finish. This minimizes the need for oil, prevents food from sticking, and makes cleaning easier.

Do not use metal cooking utensils or abrasive cleaning tools on nonstick surfaces as they will damage the coating. Use only warm soapy water and remove stubborn residue with a non-abrasive plastic scouring pad or nylon brush.

NOTE: Do not use nonstick cooking spray as they can impact the performance of the nonstick surface.

BEFORE FIRST USE

1. Before using your Air Fryer for the first time, carefully remove all packaging material and recycle appropriately.
2. Remove the parts from the box and wash the Drawer Pan and Frying Rack with warm, soapy water and a non-abrasive sponge.
IMPORTANT: DO NOT IMMERSE THE MAIN HOUSING IN WATER. Wipe the interior and exterior of appliance clean with a damp cloth.
IMPORTANT: THIS IS NOT A DEEP FRYER. DO NOT FILL THE APPLIANCE OR ITS DRAWER WITH OIL OR FRYING FAT.
3. Place the appliance on a flat, horizontal and stable surface (make sure surface is heat-resistant). Place away from walls and other appliances. Leave approximately 4 inches of space from nearby objects.

HOW TO USE

1. Carefully pull out the Drawer Pan from the Main Fryer Body by pulling forward on the Handle.
TIP: Never place food directly into the Drawer Pan without the Frying Rack inside. In place of using the Frying Rack, an oven-safe plate or bowl (not included) can be placed onto a wire rack (not included) into the Drawer Pan.
2. Place the Frying Rack into the Drawer Pan (Figure 1).
3. Place ingredients onto Frying Rack.
TIP: Do not fill the Drawer Pan over the MAX fill position. If cooking food that expands, make sure the cooked capacity will not exceed the MAX fill position.
4. Slide Drawer Pan back into the Main Body.



FIGURE 1

HOW TO PROGRAM FRYING TIME AND TEMPERATURE:

1. Plug Power Cord into an electrical outlet.
2. Turn the Temperature Control Knob to the desired temperature and then turn the Timer Control Knob to the desired time setting (the Timer must be set in order for the unit to begin heating).
TIP: It is recommended to preheat the air fryer on empty for 3 minutes if the appliance is cold or you can add 3 minutes to your desired time setting in order to pre-heat. The initial 15 minutes of use may result in minimal smell and smoke. This is normal and harmless and comes from the protective substance applied to the heating elements during manufacturing.
3. The Power Indicator will illuminate.
4. The Air Fryer will automatically Pause if the Drawer Pan is removed during the cooking cycle. Once replaced back into the fryer, the unit will continue its cooking cycle.
5. **NOTE:** Any excess oil from food will collect at the bottom of the Drawer Pan.



CAUTION:

Never place anything on top of the Main Body, for this will block the air flow and reduce the effect of hot air heating.



CAUTION:

Do not touch the Drawer Pan during and immediately after use, as it gets very hot. Only hold the Drawer Pan by the Handle.



NOTE:

Any excess oil from food will collect at the bottom of the Drawer Pan.

HOW TO USE (cont.)

DURING THE COOKING/FRYING PROCESS:

1. Some recipes require stirring/mixing the contents mid-way through cooking (see Cooking Time Chart on page 9). You can do this in the middle of the cooking process by pulling the Drawer Pan out from the Main Fryer Body. Shake or stir the contents on the rack using a non-metallic utensil and then slide Drawer Pan back into the Main Fryer Body.

TIP: If you set the timer to half the required cook time, you will hear the timer indicator when you have to stir the ingredients. However, this means that you will need to set the timer again to the remaining cook time after stirring.

2. The air fryer will resume cooking once the Drawer Pan is closed.

WHEN FRYING IS COMPLETE:

1. When the timer completes its countdown, the timer bell will ring and the air fryer will stop heating - this signals it is time to remove your food.
2. Carefully pull out the Drawer Pan from the Main Fryer Body by pulling forward on the Drawer Pan Handle and place on a flat, heat resistant surface.
3. Check that your foods are ready. If not, then place the Drawer Pan back into the Main Fryer Body and set the timer for a few more minutes.
4. Empty the contents of the Drawer Pan into a bowl or onto a plate using non-metallic tongs or a scoop.

TIP: Do not turn the Drawer Pan and Frying Rack upside down together, as any excess oil that has collected in the bottom of the Drawer Pan will be poured onto the foods.

5. When the next batch of ingredients is ready, the air fryer is instantly ready to use again.
6. When cooking is complete, remove the Power Cord from the electrical outlet.

CLEANING & MAINTENANCE

The Air Fryer should be cleaned thoroughly after every use.

1. Make sure the Power Cord is disconnected from the electrical outlet and that the appliance has cooled down before attempting to clean.
2. The Drawer Pan, Frying Rack and the inside of the appliance have a nonstick coating. Do not use metal utensils or abrasive cleaning materials on them, as this can damage the non-stick coating.
3. Wipe the outside of the appliance with a damp cloth.



CAUTION:

During cooking, the Drawer Pan and Frying Rack will be very hot, only use the Drawer Pan Handle or oven mitts.



NOTE:

You can also switch off the appliance manually by turning the Timer Control Knob to 0 at any time during the cooking process.



CAUTION:

- When sliding out the Drawer Pan, be careful of hot air and steam. Keep hands and face away from the opening.

- After cooking, the Drawer Pan and Frying Rack will be extremely hot to the touch. Do not touch surfaces of the Drawer Pan or Frying Rack directly.

CLEANING & MAINTENANCE (cont.)

- Lift the Frying Rack upwards out of the Drawer Pan (Figure 2) and clean both with hot water, dishwashing soap and a non-abrasive sponge.
- You can use a degreaser to remove any stuck-on residue.
TIP: If food residue is stuck to the Frying Rack or the bottom of the Drawer Pan, place the Frying Rack into the Drawer Pan and fill with dishwashing soap and water and let soak for 10 minutes.
- Clean the inside of the appliance with hot water and a non-abrasive sponge.
- Never immerse the power cord, plug or the appliance body in water or any other liquids.
- Dry all parts after each use, re-assemble and store in a cool, dry location.



FIGURE 2



NOTE:

The Drawer Pan and Frying Rack are dishwasher-safe (top rack only).

COOKING TIME CHART

INGREDIENTS	AMOUNT (ounces)	TIME (minutes)	TEMP. (°F)	STIR	NOTES
POTATOES					
Thin frozen fries	15 ~ 25	12-21	390	STIR	
Thick frozen fries	15 ~ 25	19-26	395	STIR	
Homemade fries (0.3"x0.3")	15 ~ 30	21-26	395	STIR	add 1/2 tbsp of oil
Homemade potato wedges	15 ~ 30	25-28	355	STIR	add 1/2 tbsp of oil
Homemade potato cubes	15 ~ 25	20-24	355	STIR	add 1/2 tbsp of oil
Homemade potato chips	10	13-14	320		

STIR means the recipe requires mixing the contents mid-way through cooking. You can do this by carefully pulling out the Drawer Pan using the Handle, which will automatically pause the cooking process. Stir the contents using a non-metallic utensil. Cooking will resume after you slide the Drawer Pan back into the Main Fryer Body.

Questions? We're here to help!
Visit: shopelitegourmet.com for support on this product.

INGREDIENTS	AMOUNT (ounces)	TIME (minutes)	TEMP. (°F)	STIR	NOTES
MEAT					
Steaks	6 ~ 18	13-16	355		
Porkchops	6 ~ 18	14-18	355		
Hamburgers	6 ~ 18	10-16	355		
Drumsticks	6 ~ 18	26-29	355		
Chicken wings	15 ~ 20	21-23	395		
Chicken strips	6 ~ 18	17-19	355		
SNACKS					
Egg rolls	6 ~ 18	13-14	395	STIR	Use oven-ready
Frozen chicken nuggets	6 ~ 18	10-13	395	STIR	Use oven-ready
Frozen fish sticks	6 ~ 14	10-13	395		Use oven-ready
Fish fillet in batter	6 ~ 18	13-19	355	STIR	
Battered shrimp	6 ~ 18	11-16	355	STIR	
Frozen cheese sticks	6 ~ 14	12-13	355		Use oven-ready
Stuffed veggies	6 ~ 14	14	320		
Mushrooms	6 ~ 14	14	320		
Onion rings	6 ~ 18	12-17	355		
BAKING					
Cake	10	30	320		Use oven-safe dish
Quiche	15	30	355		Use oven-safe dish
Muffins	10	26-30	395		Use oven-safe muffin cups
Sweet snacks	15	30	320		Use oven-safe dish



NOTE:

All information is for reference only and can be adjusted according to the user's preference. They are approximations as foods differ in size and density. Cooking temperatures and times cannot be guaranteed.

HINTS & TIPS

- Smaller cuts of food usually require a slightly shorter cooking time than larger foods.
- A larger amount of food only requires a slightly longer cooking time and a smaller amount of food only requires a slightly shorter cooking time.
- Stirring or shaking smaller foods mid-way through the cooking process will improve the end result and can help cook more evenly.
- Adding a small amount of oil to fresh potatoes can result in a crispier result. Cook your ingredients in the air fryer within a few minutes after adding the oil.
- Do not air fry extremely greasy foods such as sausages in the air fryer.
- Snacks that can be prepared in an oven can also be prepared in the air fryer.
- The air fryer can also reheat foods. To reheat foods, set the temperature to 300°F for up to 10 minutes.
- To cook frozen foods, add an additional 3-5 minutes to your cook time.

BAKING/STEAMING FOODS:

- Place a wire rack (not included) onto the bottom of the Drawer Pan and place an oven-safe dish onto the wire rack if you want to bake a cake/quiche, steam foods or if you want to air fry delicate foods or foods with fillings.
- Use pre-made dough to prepare foods with fillings quickly and easily. Pre-made dough also requires a shorter cooking time than home-made dough.
- For steaming foods, generally, 1-2 cups of water provides approximately 5-10 minutes of steam time. Add water to the Drawer Pan. Place wire rack (not included) into the Drawer Pan. Place food into an oven-safe dish (not included) and place dish onto the wire rack.

HOMEMADE FRENCH FRIES:

- The optimum amount for air frying crispy fries is 17.5oz. or a little over 1 lb.
- When making your own French fries, follow these steps:
 1. Peel potatoes and slice them into strips.
 2. Wash and dry them thoroughly.
 3. Mix potato strips in a bowl with ½ tablespoon of olive oil, make sure they are evenly coated.
 4. Using your hands or tongs, place the potato strips onto the frying rack.



NOTE:

- Add 3 minutes to the cooking time if you begin cooking while the air fryer is still cold.
- When cooking/baking foods that rise, the Drawer Pan should not be filled more than halfway.
- Do not pour the potato sticks from the bowl onto the Frying Rack to avoid transferring any excess oil into the Drawer Pan.
- Do not cook frozen, raw foods in the air fryer.

AIR FRYER RECIPES

GOLDEN FRIED ONION RINGS

6 med. mild white onions	1/4 cup olive oil
1 1/8 cup sifted flour	1 cup milk
1/2 tsp. salt	1 egg, slightly beaten

1. Slice onion 1/4 inch thick and separate into rings.
 2. Preheat air fryer to 395°F for 3 minutes.
 3. Combine remaining ingredients in a bowl and stir just until dry ingredients are moistened.
 4. Dip onion rings into flour mixture.
 5. Place into air fryer and program to cook at 395°F for 21-24 minutes.
 6. Repeat process until all onion rings are cooked.
-

BUFFALO WINGS

24 wings (4lbs.)	1/4 cup butter
Salt & pepper (optional)	2 to 5 tsp. hot sauce
2 tbsp. vegetable oil	1 tsp. white vinegar

1. Sprinkle wings with salt and pepper, to taste.
 2. Preheat air fryer to 395°F for 3 minutes.
 3. Place wings into air fryer and program to cook at 395°F for 23-29 minutes.
 4. When wings are golden brown and crisp, remove from air fryer. Add rest of wings; repeat process.
 5. Meanwhile, melt butter in saucepan; add hot sauce, to taste and vinegar. Pour sauce over wings and mix well to cover.
 6. Serve with Blue Cheese Dressing and celery sticks.
-

POTATO CROQUETTES

2 tbsp. milk	3 tbsp. flour
salt	4 c. mashed potatoes
1/2 tsp. pepper	1 egg, beaten
1/2 tsp. chopped green onion	Sifted dried bread crumbs
2 egg yolks, beaten	2 tbsp. peanut oil

1. Add milk, salt, pepper, chopped green onion, oil, beaten egg yolks and flour to mashed potatoes.
2. Preheat air fryer at 395°F for 3 minutes.
3. Chill and shape using an ice cream scoop. Dip in the beaten egg, then roll through bread crumbs. Place into air fryer and program to cook at 395°F for 12-14 minutes or until golden brown.
4. Note: Cook in small batches, giving each croquette at least 2 inches of space around it to not overcrowd the rack. Repeat process until all croquettes have been cooked.

HOMEMADE BLACK PEPPER POTATO CHIPS

6 Yukon gold potatoes, unpeeled
2 tbsp. canola or vegetable oil
Kosher salt and black pepper

1. Preheat air fryer to 395°F.
2. Wash and clean the potatoes in cold running water. Using a mandoline, or vegetable peeler, finely slice the potatoes into chips. Drop the chips into a bowl of ice water as you work to prevent them from going brown. This will also remove any excess starch. Soak in water for 30 minutes and change the water at least 4 times.
3. Toss the chips in the canola or vegetable oil.
4. Place chips into air fryer and program to cook at 395°F for 23 minutes. Stir the potatoes. Then cook for another 23 minutes.
5. When finished cooking, immediately sprinkle on salt and a lot of black pepper. Repeat with the rest of the potatoes. Serve very soon after frying.

FRIED GREEN TOMATOES

3 to 4 large green tomatoes	1 tbsp. seasoning salt
2 cup flour	2 eggs
1 tbsp. salt	2 cup milk
1 tbsp. pepper	1/4 cup olive oil

1. Cut tomatoes into almost 1/2 inch thick slices.
2. Mix flour, salt, pepper and seasoning salt in one bowl.
3. Preheat air fryer to 395°F for 3 minutes.
4. Mix eggs, oil and milk in another bowl. Dip each tomato slice into the milk mixture, then into the flour, back to the milk and then to the flour again, coating well.
5. Place tomato slices into air fryer and program to cook at 395°F for 19-22 minutes. Repeat process until all tomatoes are fried.

CORN DOGS

1/2 c. yellow cornmeal	6 skewers or sticks
1/2 c. flour	1 tbsp. sugar
1/4 tsp. dry mustard	1 tsp. baking powder
1/2 tsp. salt	1/2 c. milk
1 egg, lightly beaten	1 tbsp. melted shortening
6-8 hot dogs / frankfurter	2 tbsp. vegetable oil

- Combine the cornmeal, flour, sugar, mustard, baking powder and salt, mixing well. Add the milk, egg, oil and shortening, mixing until very smooth. Preheat air fryer to 395°F for 3 minutes. Pour the mixture into a tall glass. Put the frankfurters on sticks. Dip them into the cornmeal batter to coat them evenly.
- Place into air fryer and program to cook at 395°F for 15-21 minutes or until evenly cooked. Repeat process until all hot dogs are cooked.

BEER BATTERED FISH FILETS

1 cup flour	1/2 cup milk	SAUCE
1 tsp. salt	2 eggs	1 cup Pea Shoots
1 tsp. baking powder	2 pounds cod fillets	1 cup baby lettuce leaves
1/2 tsp. dried dill weed	2 tbsp. vegetable oil	1/3 cup lowfat mayonnaise
3/4 cup beer		1/3 cup lowfat plain yogurt

- In a large bowl, mix together flour, salt, baking powder, and dill. Add beer, milk, oil, and eggs; mix well.
- Place fish fillets in batter mixture, coat well, and let stand for 15 minutes.
- Preheat air fryer to 395°F for 3 minutes. Place fish into air fryer and program to cook at 395°F for 15-21 minutes. Repeat process until all fish is cooked.
- For sauce, puree everything up in a food processor and sprinkle with paprika (optional).

MAPLE SALMON

1/4 cup maple syrup	1/4 tsp. garlic salt
2 tbsp. soy sauce	1/8 tsp. ground black pepper
1 clove minced garlic	1 pound salmon

- In a small bowl, mix the maple syrup, soy sauce, garlic, garlic salt, and pepper.
- Place salmon in a shallow glass baking dish, and coat with the maple syrup mixture. Cover the dish, and marinate salmon in the refrigerator 30 minutes, turning once.
- Preheat air fryer to 395°F. Place salmon onto frying rack. Program to cook at 395°F for 14-18 minutes or until easily flaked with a fork.
- Serve on bed of greens.

FISH STICKS WITH YOGURT DIP

8 oz. center-cut salmon fillet, skinned	1 cup seasoned bread crumbs
1/2 cup flour	olive oil, for drizzling
1/2 tsp. fine sea salt	1/3 cup lowfat mayonnaise
1/4 tsp. freshly ground black pepper	1/3 cup lowfat plain yogurt
3 egg whites	1 tbsp. dijon mustard
1 cup grated parmesan	1 tbsp. chopped fresh parsley or chives

1. Preheat air fryer to 395°F. Rinse salmon fillet and pat dry with paper towels. Slice fish so all the pieces are equally about 1/2 by 1/2 by 4 1/2-inches in size.
2. Place flour, salt, and pepper in a medium bowl. Place egg whites in another bowl and beat until frothy, about 30 seconds. Combine grated parmesan and bread crumbs in a third bowl.
3. Coat salmon pieces in the flour and pat to remove any excess flour. Dip floured fish sticks in egg whites and then into the parmesan mixture.
4. Place the breaded fish sticks into air fryer and lightly drizzle with olive oil. Program to cook at 395°F for 16-21 minutes or until golden brown. Repeat process until all fish sticks are cooked.
5. For dipping sauce: mix mayo, yogurt, dijon, and parsley (or chives) in a small dipping bowl.

CHICKEN TENDERS WITH HONEY MUSTARD SAUCE

2 pounds boneless, skinless chicken breasts	1 tsp. garlic powder	HONEY MUSTARD:
3 eggs	1 tsp. lemon pepper	1/2 cup dijon mustard
1 cup flour	1/2 tsp. cayenne	1/2 cup honey
2 cups panko bread crumbs	1/2 tsp. salt	2 tbsp. mayonnaise
	1/2 tsp. pepper	1 tbsp. lemon juice
		Salt and pepper

1. Preheat air fryer to 330°F. Cut the chicken breasts into long strips and set aside.
2. Beat the 3 eggs in a separate bowl and place the flour into another separate dish. Pour the panko into a pie plate or shallow bowl and season with garlic powder, lemon pepper, cayenne, salt and pepper.
3. Dip the chicken strips into the flour, then beaten egg and the dredge them into the seasoned panko. Place chicken tenders into air fryer and program at 330°F for 15-20 minutes. Mid-way through cooking, toss/stir the chicken tenders. Repeat process until all chicken is cooked. Serve with honey mustard sauce.
4. Honey mustard: mix all the ingredients in a small bowl and season with salt and pepper. process until all tomatoes are fried.

SWEET & SOUR CHICKEN

4 cornish game hens	24 cloves garlic
salt and pepper to taste	1/3 cup white wine
1 lemon, quartered	1/3 cup low-sodium chicken broth
4 sprigs fresh rosemary	4 sprigs fresh rosemary for garnish
3 tbsp. olive oil	

1. Combine marinade ingredients in a small bowl. Add chicken, mix well. Let stand 30 min.
2. Combine batter ingredients in a medium bowl until just mixed. Do not stir to blend.
3. Combine sweet & sour sauce, chicken broth, water and cornstarch in a small bowl, set aside.
4. Preheat air fryer to 395°F for 3 minutes.
5. Coat each piece of chicken with batter and place into air fryer. Program to cook at 395°F for 18-30 minutes, checking for doneness. Repeat until all chicken is cooked.
6. Using a fry pan, place oil, heat to medium. Stir-fry green peppers, carrots and water chestnuts for 2 minutes. Add sweet & sour sauce mixture. Stir in pineapple. Stir-fry until sauce has thickened. Remove from heat. Stir in chicken and serve immediately. Makes 4 servings.

SKIRT STEAK WITH CILANTRO GARLIC SAUCE

STEAK:	SAUCE:
1 tsp. ground cumin	1 medium garlic clove
1/2 tsp. salt	1/2 tsp. salt
1/2 tsp. black pepper	1 cup coarsely chopped fresh cilantro
Two 16oz skirt steaks	1/4 cup olive oil
	2 tbsp. fresh lemon juice
	1/8 tsp. cayenne

1. For the sauce: mince garlic and mash to a paste with salt. Transfer to a blender and add remaining sauce ingredients, then blend until smooth.
2. Preheat air fryer to 395°F. Stir together cumin, salt, and pepper in a small bowl. Pat steak dry, then rub both sides of steaks with cumin mixture.
3. Place into air fryer and program to 395°F for 15-18 minutes (medium rare). Repeat process for 2nd steak. Serve steak drizzled with sauce.

CHURROS

1 cup water	1 cup flour
1/2 cup margarine or butter	3 eggs
1/4 tsp. salt	1/4 cup sugar
	1/4 tsp. ground cinnamon

1. Preheat air fryer to 355°F for 3 minutes.
2. To make churro dough, heat water, margarine and salt to a rolling boil in sauce-pan; stir in flour. Stir vigorously over low heat until mixture forms a ball, about 1 minute; remove from heat.
3. Beat eggs all at once; continue beating until smooth and then add to saucepan while stirring mixture. Spoon mixture into cake decorator's tube with large star tip (like the kind use to decorate cakes).
4. Squeeze 6-inch loops of dough into drawer pan. Do not overlap. Program to cook at 355°F for 23-30 minutes. Repeat process until all churros are cooked.
5. Mix sugar and the optional cinnamon; roll churros in sugar mixture.

MINI CHEESECAKES**FILLING:**

1 (8oz) package cream cheese, softened	1/2 tsp. grated lemon zest
1/4 cup white sugar	1/4 tsp. vanilla extract
1 1/2 tsp. lemon juice	1 egg

CRUST:

1/3 cup graham cracker crumbs
1 tbsp. white sugar
1 tbsp. margarine, melted

1. Preheat air fryer to 330°F for 3 minutes. Grease 12 mini muffin cups.
2. In a medium bowl, mix together the graham cracker crumbs, sugar, and margarine with a fork until combined. Measure a rounded tablespoon of the mixture into the bottom of each muffin cup, pressing firmly.
3. Place muffin cups into air fryer. Program at 330°F for 9 minutes, then remove to cool. Beat together the cream cheese, sugar, lemon juice, lemon zest and vanilla until fluffy. Mix in the egg. Pour the cream cheese mixture into the muffin cups, filling each until 3/4 full.
4. Program at 330°F for 19-22 minutes. Repeat process until all cheesecakes are cooked.

APRICOT POCKET PIES

4 apricots	cinnamon, for sprinkling
4 tsp. butter	14 oz. store bought pie dough
8 tsp. brown sugar	

1. Preheat air fryer to 345°F. Halve the 4 apricots and remove pits.
2. Place 1/2 tsp. butter, 1 tsp. brown sugar, and a pinch of cinnamon inside each of the 2 halves, then put the halves back together.
3. Roll out a 14 oz (9-inch) store-bought pie crust dough and cut four 6-inch circles. Wrap each whole apricot in a circle of dough and pinch the edges to enclose fully. Sprinkle the tops of the pies with the sanding sugar.
4. Place pocket pies pinch side down into air fryer. Program to 345°F for 30 minutes or until golden

TROUBLESHOOTING GUIDE

PROBLEM	POSSIBLE CAUSE	SOLUTION
The airfryer does not work.	The appliance is not plugged in.	Plug the Power Cord into an electrical outlet.
	You have failed to set the timer.	Turn the timer knob to set the right time needed for cooking.
	The appliance is defective.	Contact customer service at shopelitegourmet.com
Food is not completely cooked/fried.	There is too much food in the Drawer Pan.	Use smaller batches of food in the Drawer Pan. Small batches of food will cook more evenly.
	The cooking temperature is set too low.	Increase the temperature setting. Check "Cooking Time Chart" found in this manual.
	The cooking time is too short.	Increase the time setting. Check "Cooking Time Chart" found in this manual.
	Food is raw and frozen solid.	Raw frozen foods should be thawed before cooking in the air fryer. Exceptions to this are pre-cooked frozen foods.
Food is unevenly cooked.	Certain foods need to be stirred mid-way through the cooking process.	Foods that overlap inside the Drawer Pan need to be stirred mid-way through cooking.
Fried snacks are not crispy.	You used a type of snack meant to be prepared in a traditional deep fryer.	Use oven snacks or lightly brush some oil onto the snacks for a crispier result.
I cannot close the Drawer Pan properly.	The Drawer Pan is too full.	Do not overfill the Drawer Pan.
	The Drawer Pan is not properly placed inside.	Make sure there is no obstruction for the Drawer Pan to close properly.
White smoke is emitting out of the appliance during use.	You are preparing food with a high oil content.	When cooking with oily foods, oil will drain into the Drawer Pan. When the air fryer heats up, the pan heats up the oil and produces white smoke. This does not adversely affect the air fryer or your cooking process.
	The pan has built-up oil residue from previous uses.	White smoke is caused by oil leftover in the Drawer Pan. Make sure to thoroughly clean the Drawer Pan after every use.
Home-made French fries are coming out unevenly cooked.	Your potatoes are not fresh or are frozen.	Make sure to use fresh and firm potatoes, not frozen potatoes, for home-made French fries.
	Potato strips were not well rinsed prior to frying.	Thoroughly rinse sliced potato to remove all starch prior to frying.
Home-made French fries are not crispy after air frying.	Crispy results are directly linked to the amount of oil used and water content of the potato.	Potato strips need to be thoroughly dried before adding oil.
		Slice potato strips thinner if you want them crispier.
		Use a bit more oil on the potato strips prior to frying if you want crispier results.

LIMITED WARRANTY* ONE (1) YEAR
WARRANTY IS ONLY VALID WITH A DATED PROOF OF PURCHASE

PLEASE DO NOT RETURN TO STORE OF PURCHASE.

If you have any problems with this unit, contact Customer Service for support.

1. Your small kitchen appliance is warranted to the original purchaser to be free from any manufacturing defects under normal use and conditions for one (1) year, cord excluded. This Warranty applies only to the original purchaser of this product.
2. Retail stores/merchants selling this product do not have the right to alter, modify, or in any way revise the terms and conditions of the warranty.
3. If you use your appliance for household use and according to instructions, it should give you years of satisfactory service.
4. At its sole discretion, Maxi-Matic USA will either repair or replace the product found to be defective during the warranty period.
5. The repaired or replacement product will be in warranty for the remaining balance of the one-year warranty period and an additional one-month period.
6. Consumer's remorse is not an acceptable reason to return a product to our Service Center.
7. This limited warranty covers appliances purchased and used within the 50 U.S. states plus the District of Columbia and does **NOT** cover normal wear of parts or:
 - Damages caused by unreasonable use, neglect, normal wear and tear, commercial use, improper assembly or installation of product.
 - Damages caused in shipping.
 - Damages caused by replacement or resetting of house fuses or circuit breakers.
 - Defects other than manufacturing defects.
 - Breakage caused by misuse, abuse, accident, alteration, lack of proper care and maintenance, or incorrect current or voltage.
 - Lost or missing parts of the product. Parts will need to be purchased separately.
 - Damages of parts that are not electrical; i.e. cracked or broken plastic/glass, scratched/dented inner pots.
 - Damage from service or repair by unauthorized personnel.
 - Extended warranties purchased via a separate company or reseller.
 - Acts of nature such as fire, floods, hurricanes, tornadoes, etc.

8. This warranty does not apply to re-manufactured merchandise.

Maxi-Matic, USA shall not be liable for any incidental or consequential damages caused by the breach of any express or implied warranty. Apart from the extent prohibited by applicable law, any implied warranty of merchantability or fitness for a particular purpose is limited in time to the duration of the warranty.

*One Year Limited Warranty valid only in the 50 U.S. states plus the District of Columbia, excluding Puerto Rico and the Virgin Islands.

This warranty is effective only if the product is purchased and operated in the USA; product usage which is in violation of the written instructions provided with the unit will void this warranty. For international warranty, please contact the local distributor.

This warranty gives you special legal rights and you may also have other rights to which you are entitled which may vary by state, province, and/or jurisdiction.

**Any instruction or policy included in this manual may be subject to change at any time.

MAXI-MATIC, USA

18401 E. Arenth Ave. City of Industry, CA 91748

Visit: shopelitegourmet.com for Live Chat Support and Contact Us Form

RETURN INSTRUCTIONS

RETURNS:

- A. Any return of defective merchandise to the manufacturer must be processed accordingly by first contacting customer service to obtain an RA # (Return Authorization Number). We will not accept any returns of merchandise without an applicable RA #.
- B. **IMPORTANT RETURN INSTRUCTIONS.** Your Warranty depends on your following these instructions if you are returning the unit to Maxi-Matic, USA:
1. Carefully pack the item in its original carton or other suitable box with sufficient cushioning to avoid damage in shipping.
 2. Before packing your unit for return, be sure to enclose:
 - a) Your name, full address with zip code, daytime telephone number, and RA#,
 - b) A dated sales receipt or PROOF OF PURCHASE,
 - c) The model number of the unit and the problem you are having (Enclose in an envelope and tape directly to the unit before the box is sealed,) and
 - d) Any parts or accessories related to the problem.
 3. Maxi-Matic, USA recommends that you ship the package via UPS ground service for tracking purposes. **We cannot assume responsibility for lost or damaged products returned to us during incoming shipment.** For your protection, always carefully package the product for shipment and insure it with the carrier. C.O.D shipments cannot be accepted.
 4. **All return shipping charges must be prepaid by you.**
 5. Once your return has been received by our warehouse, Maxi-Matic, USA will repair or replace the product if it is defective in material or workmanship, subject to the conditions in paragraph B.
 6. **Maxi-Matic will pay the shipping charges to ship the repaired or replacement product back to you.**

Elite Gourmet

Elite Customer Service Center

Mail: Maxi-Matic, USA
18401 E. Arenth Ave
City of Industry, CA
91748-1227

Website: shopelitegourmet.com
Visit our website for Live Chat Support
& Contact Us Form
Register your product online



We take pride in the fact that Elite Gourmet products are continuously improving. To keep you well informed of these changes and to reduce paper consumption, we've included this QR code for you to scan and easily download the most recent updates to your product to your mobile device.

It's simple, just access your camera, point at the QR code & your mobile device will do the rest.



[elitebymaximatic](https://www.facebook.com/elitebymaximatic)



[@elite_by_maximatic](https://www.instagram.com/elite_by_maximatic)

Elite is a registered trademark of Maxi-Matic, USA.
Copyright Elite by Maxi-Matic.

Actual product may vary from the images/illustrations in this manual due to continual product improvement.

MODEL: EAF-0201(A~Z)