

Liv EZ
Built-in Filtered Water Dispenser
Non-Refrigerated

ELKAY[®]

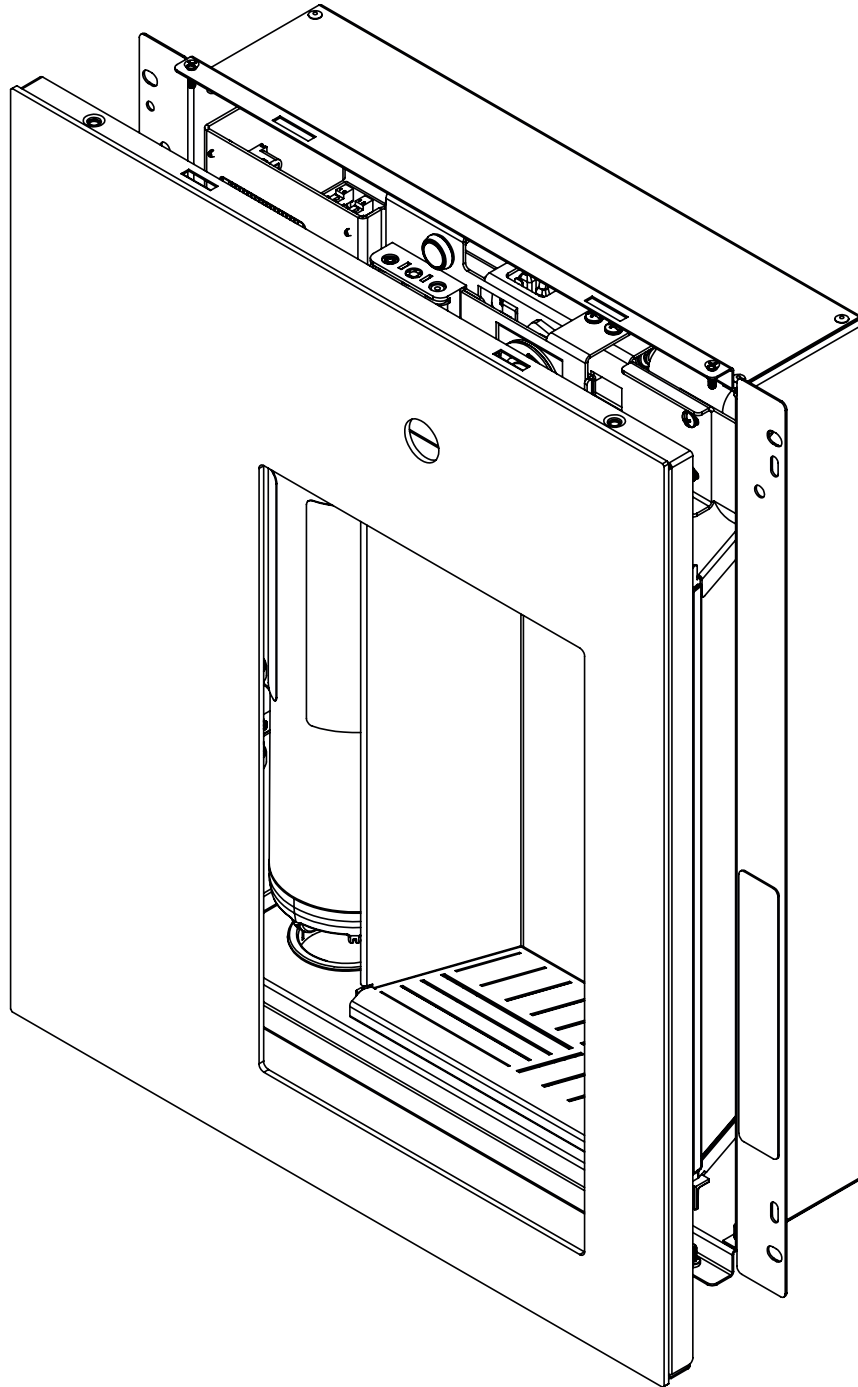

Installation & Ownership Manual

Congratulations on Your New Liv EZ Built-in Filtered Water Dispenser!

Let's get it set up so you can start drinking
cleaner, safer water in no time.

Table of Contents

General Information	6
About the Manual	6
Models Covered in Manual	6
Serial Number Location	6
Contact Information	6
Disclaimer	7
Notice of Changes	7
Safety	7
General Safety	7
Safety Alert Symbol	7
Personal Safety	7
Property Damage	8
Preparing to Install	8
Get to Know Your Liv	9
Components	9
Key Features	10
What's in the Box	10
Easy Installation	11
Tools You'll Need	11
Critical Depth Check and Mounting Dimensions	12
Installation	12
Startup	14
Prepare for First Use	14
Filter Status Light	15
Replacing the Filter and Batteries	16
Reset Filter Status Light and Battery Replacement	17
Replacement Parts	18
Troubleshooting	19

What to Expect From Elkay®

This isn't our first rodeo — in fact, your new Liv EZ water dispenser is based on Elkay's award-winning bottle filling station you've seen in schools, airports and other public spaces. Now enjoy the same powerful water filtration for safer, better-tasting water right at home.

Elkay's Liv EZ Gives You:

- Industry-leading filtration
- Convenient access to hydration in any room where there's a water line
- An intuitive design that's easy to install and maintain
- A sustainable, space-saving alternative to disposable plastic bottles and jugs

As a long-time advocate for sustainability, Elkay continues to make a positive environmental impact. Our bottle filling stations alone have saved 103 billion disposable single-use plastic bottles from ending up in landfills. We're delighted to have you on this sustainable journey with us and hope that you enjoy your new Liv EZ water dispenser for years to come.

- Your drinking water experts at Elkay

General Information

Installation Manual

Carefully read, understand and follow all instructions in this manual before starting installation, and familiarize yourself with all components of your Liv EZ. The installation of this product requires connection to a cold water line. If you are unsure or not qualified to make these connections, consult a qualified plumber or Elkay Installation Services. This manual contains step-by-step installation instructions for the Liv EZ built-in filtered water dispenser. Followed carefully, these instructions will result in trouble-free installation. Additional use and care documents can be found at elkay.com/support.

Any deviations, additions or deletions from the described methods, without the prior written approval of our Customer Care department, will void the warranty covering this product. Make sure the installation and use of this product meet all local, state and federal plumbing codes. This product is covered by a Limited Warranty and Elkay will not be held responsible for damage of any kind in connection with the installation of the product. View warranty at elkay.com/warranty and select "drinking water products."

WARNING

Improper installation, use or maintenance of this product could cause a dangerous situation resulting in personal injury or even death. Do not operate power tools unless you read and understand the instructions and warnings in this and all other applicable manuals. Proper use of tools and the products described in this manual is your responsibility.

NOTICE

Failure to follow these instructions could also cause a situation that results in water damage, or other damage to floors, walls, pipes or electrical wiring.

Models Covered in Manual

LBWDM0BKBC Midnight
LBWDM0WHBC Aspen White
LBWDM0SSBC Steel Gray

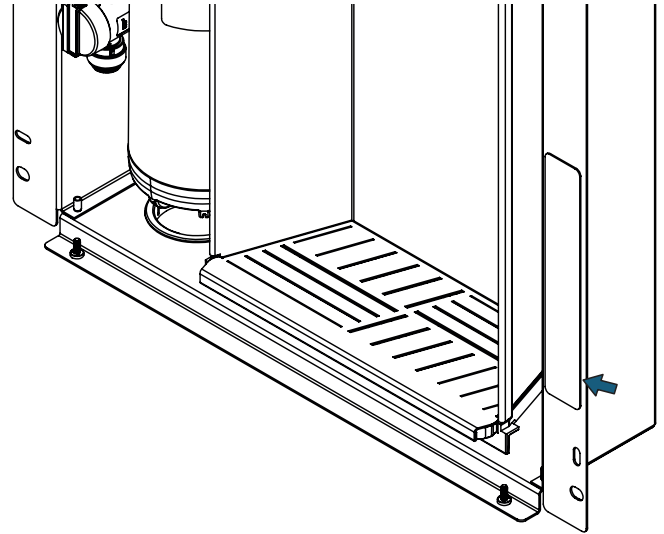

Serial Number Location

Locate the serial number under the front panel, as shown. Use when contacting Elkay Customer Care with questions concerning the installation of this product.

Contact Information

General Information

Elkay Manufacturing Company
1333 Butterfield Road Suite 200
Downers Grove, IL 60515
Phone: 630.574.8484
Email: consumer@elkay.com
Website: elkay.com

USA/Canada Customer Care
Phone: 800.476.4106
Phone: 800.260.6640 (Repair Service)
Email: CustCare@elkay.com

International Customer Care
Phone: 630.575.4755
Email: IntlCare@elkay.com

Installation Services
Phone: 800.952.8064
Email: installservice@elkay.com
Website: elkay.com/contact-us/install

Disclaimer

The information contained in this manual is given free of charge and is based on reliable technical data, intended for people with the technical knowledge to install, use and maintain this product at their own discretion and risk. Elkay assumes no responsibility for results obtained or damage incurred from the use of this material either in whole or in part by the buyer.

Notice of Changes

The information, specifications and illustrations in this manual are based on the information that was available at the time this material was written and can change at any time.

Safety

General Safety

The Elkay Manufacturing Company (Elkay) cannot anticipate every possible circumstance that might involve a potential hazard during the installation or maintenance of this product. The warnings and instructions in this installation manual are, therefore, not all-inclusive. If a tool, installation procedure or work method that is not specifically recommended by Elkay is used, you must be satisfied that it is safe for yourself and others. You should also make sure that the product will not be damaged by the methods you choose.

As you install and maintain this product, be aware of potential hazards. You should also have the necessary training, skills and tools to perform any installation or maintenance procedure.

Safety Alert Symbol

This is the safety alert symbol. It is used to alert you to potential personal injury hazards. Obey all safety messages that follow this symbol to avoid possible injury or death. This manual contains WARNINGS, CAUTIONS, NOTICES, SAFETY INSTRUCTIONS and NOTES, which must be followed to prevent the possibility of improper service, damage to the equipment, personal injury or death.

Personal Safety

WARNING

- For use with clean, clear potable drinking water only. Do not use with water that is microbiologically unsafe or of unknown quality without adequate disinfection before the system

- Installation and connection to water must comply with local and national laws
- All installation and service work must be performed by authorized service personnel

Personal Protection



To avoid eye injury, always wear protective glasses with side shields when using power tools. Make sure no one else can be injured by flying particles when using power tools.



Always wear ear protection, such as earmuffs or earplugs, when using power tools.



Wear protective, cut-resistant gloves during installation to protect against sharp edges from sheet metal components.



Power Tool Hazard

To prevent personal injury or possible death, always follow the electrical safety recommendations of the power tool's manufacturer.

- Do not use power tools in an unsafe manner
- Power tools should only be connected to a circuit protected by a ground-fault circuit interrupter (GFCI)
- If an extension cord is required, always use an appropriate one



Shock and Electrocutation Hazards

Failure to follow these instructions could result in severe electrical burns, significant injuries and even death.



Coming into contact with a source of electricity and water simultaneously will create a short circuit, which could result in injury or death.



- Never use electric power tools around water or wet floors or surfaces
- Keep all liquids away from electrical cords and power tools
- Always use an appropriate extension cord if one is required
- Make sure all related circuit breakers are turned OFF

⚠️ WARNING



Prior to installation, test for live circuits or wiring inside the wall before cutting or drilling into the wall. Before working near any electrical circuit or wiring, disconnect power and use a circuit tester to verify the power has been disconnected.

⚠️ CAUTION

These cautions indicate a potentially hazardous situation which, if not avoided, may result in minor or moderate injury.

Follow all instructions related to installation and/or maintenance of this product. This appliance can be used by children ages 8 years and older and by people with reduced physical, sensory or mental capabilities or lack of experience and knowledge, if they have been instructed how to use the product safely. Children should not play with the appliance. Children should not clean or maintain the product without adult supervision.



Tripping Hazard

Personal injury can result from tripping over power cords, tools or other installation items. DO NOT leave items laying around the work area.



Cutting Hazard

The installation of this product requires use of power tools. Keep hands away from the cutting edge of any tool used in the installation of our product. Placing fingers in or around the cutting blades could result in serious injury.



Use Proper Tools

Always use proper tools which are in good working condition during the installation of the product.

Property Damage

⚠️ NOTICE



Inspect Before Cutting

Make sure no electrical wiring or plumbing is present before cutting into a wall.

Preparing to Install

For correct and safe installation, please read these instructions completely.

⚠️ DANGER

Disconnect electrical supply serving the installation area to reduce risk of electrocution. Unit not suitable for installations where water jets might be used.

⚠️ WARNING

- Shut off water supply serving the installation area to reduce risk of water damage
- Flush all water lines and fittings before connecting to your water dispenser
- Warranty is void if installation is not performed in accordance with current manufacturing instructions

⚠️ CAUTION

Hose sets are not to be used for connecting the water dispenser to water mains. If inlet pressure is above 105 psi (0.72 MPa), a pressure regulator must be installed in the water supply line. Any damage caused by connecting this product to a water supply line with a pressure outside its rated pressure is not covered by warranty.

⚠️ NOTICE

- This water dispenser is designed for indoor use only and should not be installed outdoors, on exterior walls or in a humid environment
- Make sure the water supply pressure to the product is between 40 and 105 psi to avoid damage; product used with filter requires 40 psi, but 60 psi is optimal. Noise level is lower than 70 dB
- Use care when opening and removing the packaging to prevent damage to the product
 - Inspect the product for any shipping damage and report it immediately to the location of purchase. Installation of a damaged product will void the warranty
 - Confirm you've received all included parts for proper installation of this product. Contact the location of purchase if damaged parts are found or parts are missing
- Make sure no electrical wiring, potable water inlet pipes or drain water outlet pipes will be damaged during installation of the product

Get to Know Your Liv

Components:

1. Dispensing Spout
2. Bottles Saved Green Ticker™
3. Filter Replacement Light
4. 12"-High Stainless Steel Alcove
5. Mechanical Push Button
6. Drip Tray
7. Removable Glass Front Panel
8. Phillips head screws

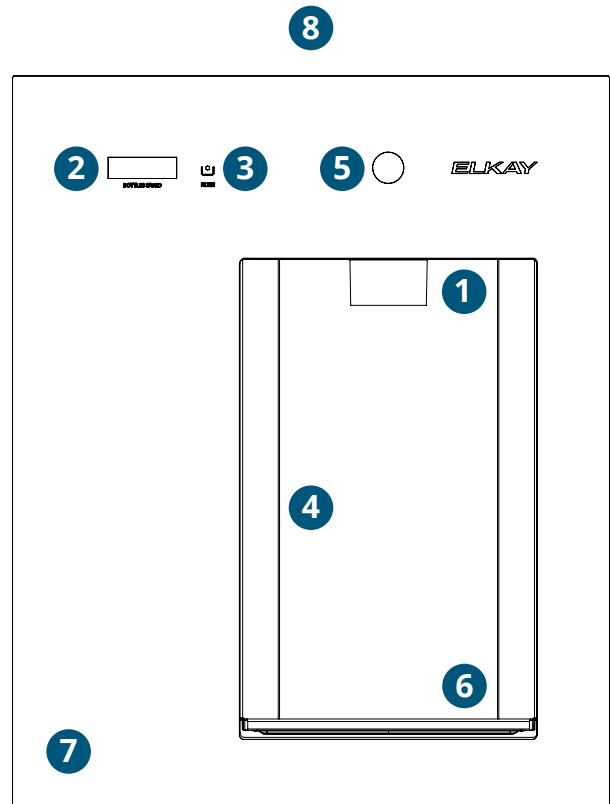

Components:

1. Battery Compartment
2. Filter
3. Water Line Connection
4. Filter Reset Button

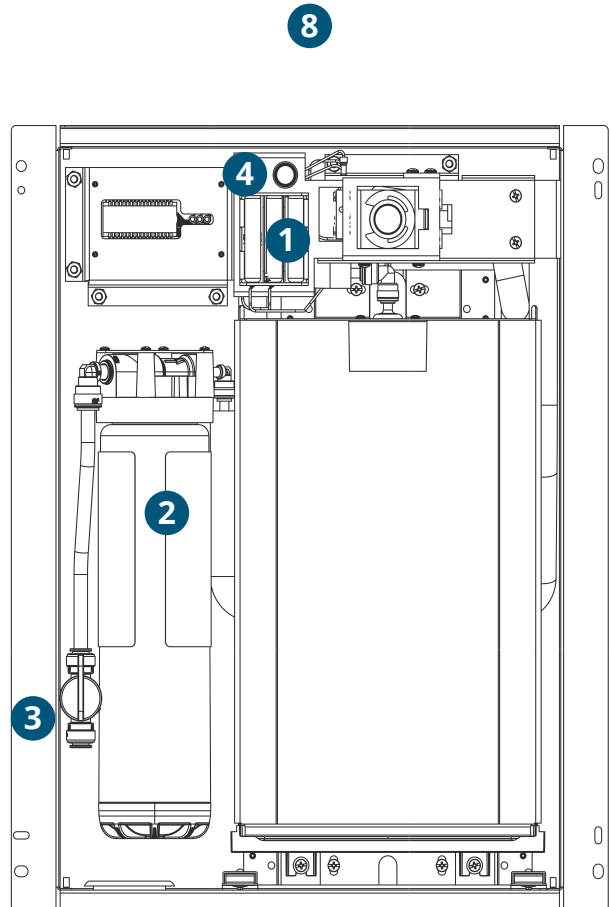

Key Features



Built-in Design

Install into the walls of convenient areas of the home



Easy to Install

No electricity required; only one water line needed



Filtered Water

Filter is tested and certified to NSF/ANSI 42, 53, 372 and 401 to reduce PFOA/PFOS, lead, microplastics and more

FILTER STATUS



Never Miss a Filter Change

LED status light indicates when a filter change is needed



See Plastic Saved

Green Ticker™ counts number of disposable, single-use plastic bottles saved



Battery Powered

Conveniently uses 3 AA batteries that last up to a year



Seamless Design

Fits into the wall for a sleek aesthetic



Easy to Maintain

Panel is easy to remove to reveal filter and batteries

What's in the Box

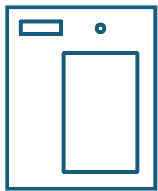

(1) Liv EZ water dispenser



(1) Elkay WaterSentry® 71300C filter



(4) Phillips Head Screws

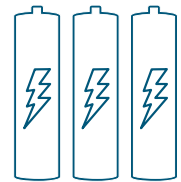

(3) AA Batteries

Easy Installation

Tools You'll Need



Safety Glasses

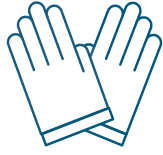

Protective Gloves



Phillips Head Screwdriver



Tape Measure

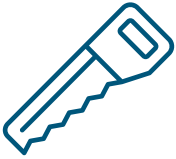

Wall Cutting Tool



Level



**Various Plumber's
Hand Tools**



**(4) Screws for Wall
Installation (Not Included)**

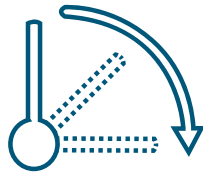

**Quarter-Turn Shutoff
Valve for Main Water
Supply (Not Included)**

Critical Depth Check and Mounting Dimensions

Make sure the wall cavity is deep enough to house the water dispenser (dimension E). Water dispenser is 3-1/2" (89 mm) deep.

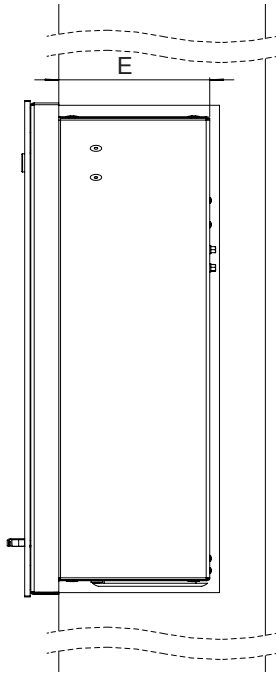

Dimension E is a minimum depth requirement.

Recommended Dimensions

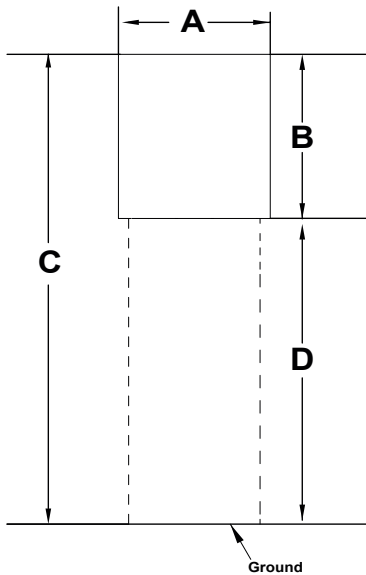

- A- Unit width opening should be 14-1/2" (368 mm) wide
- B- Unit height opening should be 19-1/2" (495-3/10 mm)
- C- Suggested unit height from the floor is 59-2/5" (1,508 mm)
- D- Optional cut from bottom of water dispenser to floor for plumbing access

Plumbing Connections

- 1 - 3/8" flexible water tubing
- 2 - 1/4" flexible water tubing

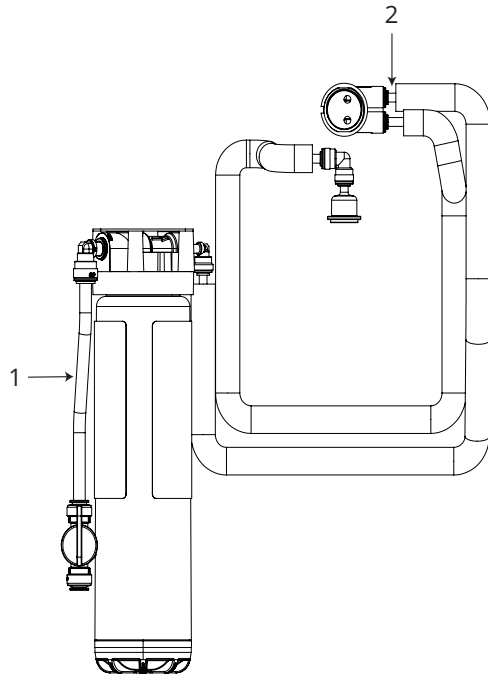

Note: Always consult local plumbing codes prior to installation.

Installation

Preinstallation: Elky recommends installing a shutoff valve at the source of the water supply for the water dispenser.

1. Cut an opening into the wall using the recommended mounting dimensions as a guide: 19-1/2"H x 14-1/2"W; recommended height from floor is 59-2/5".

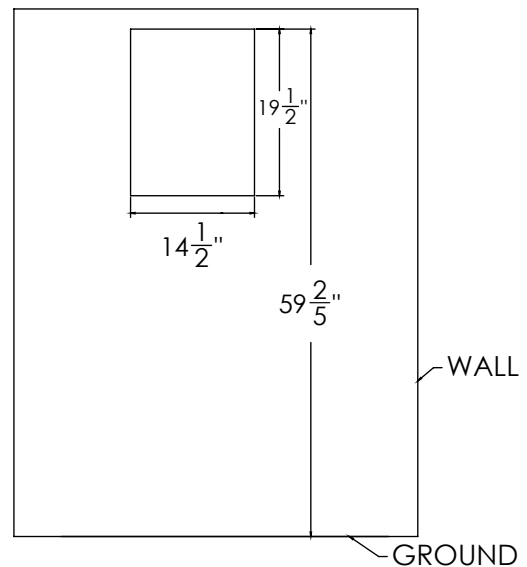

2. Route the 3/8" water line through the designated opening at the base of the dispenser. Carefully tilt the dispenser to position it within the wall cavity.

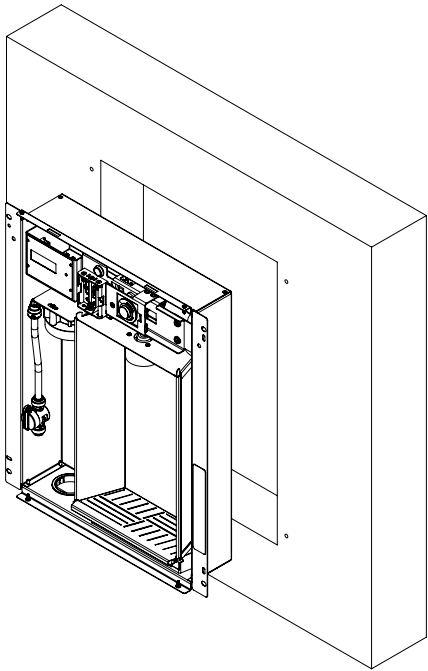

4. Using a bubble level, straighten the water dispenser and attach it to the wall studs using (4) screws (not included).

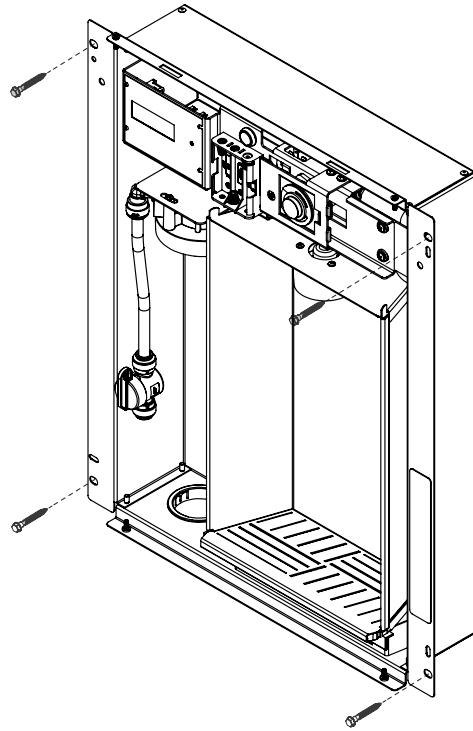

3. Place the water dispenser into the wall cavity and slide it up against the drywall at the top of the opening. The unit is designed with 1/4" overlap to conceal any irregularities at the top of the wall opening.

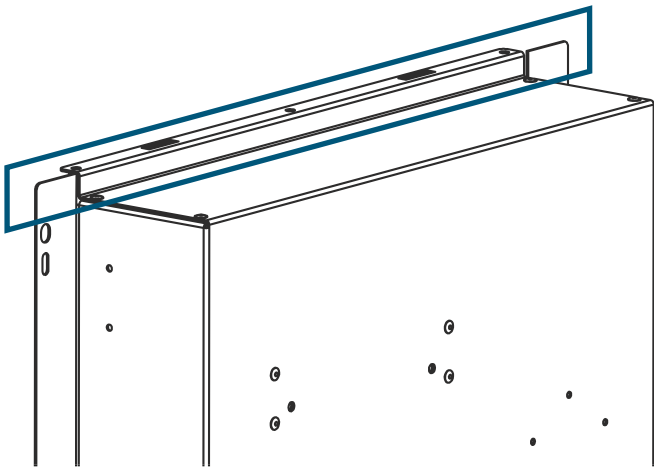

5. Install 3-AA batteries

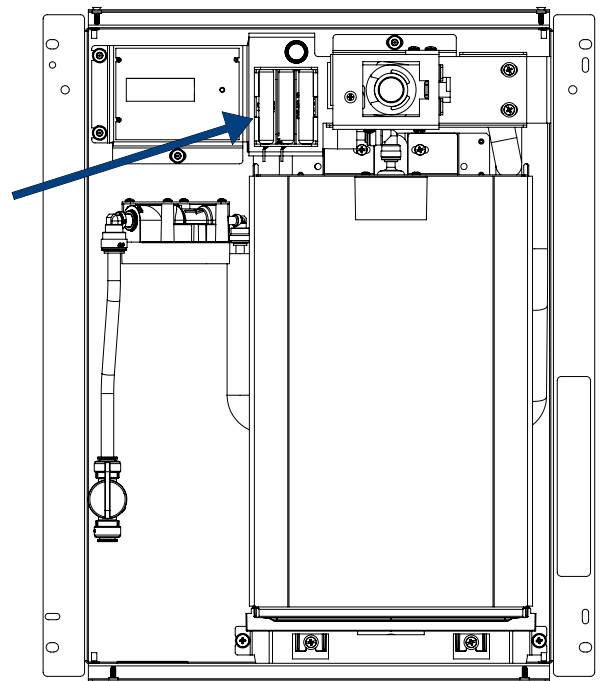

Startup

Prepare for First Use

6. Install the new filter by inserting it into the filter head and turning it clockwise to lock in place.

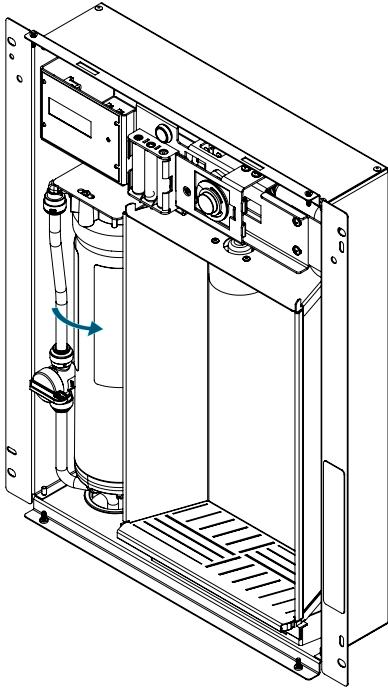

1. Open the shutoff valves in the water dispenser and at the water supply. Check for any water leaks.

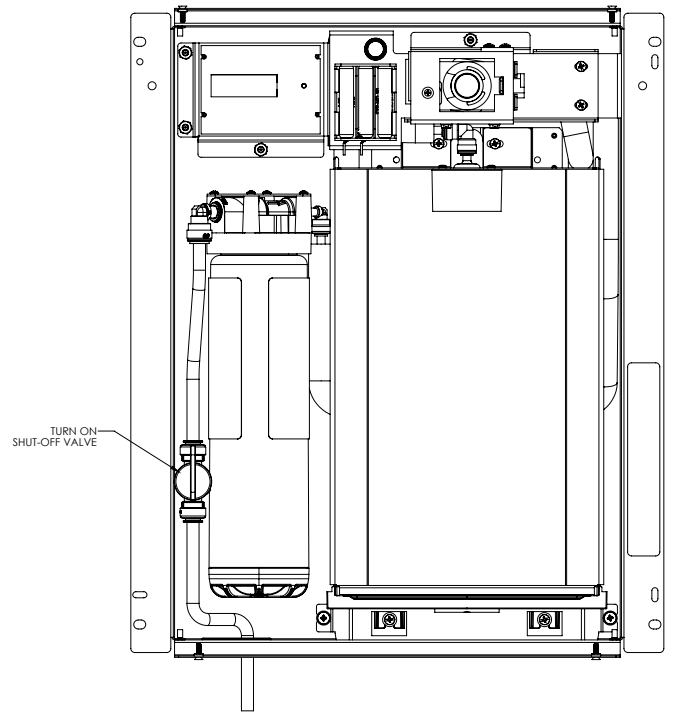

- 7.
8. Connect the 3/8" water line to the shutoff valve, located at the filter's inlet.

2. Place a container under the water dispenser spout and push the button to dispense at least one gallon of water. This is to release any trapped air from the supply lines and filter and to flush fine carbon particles from the filter.

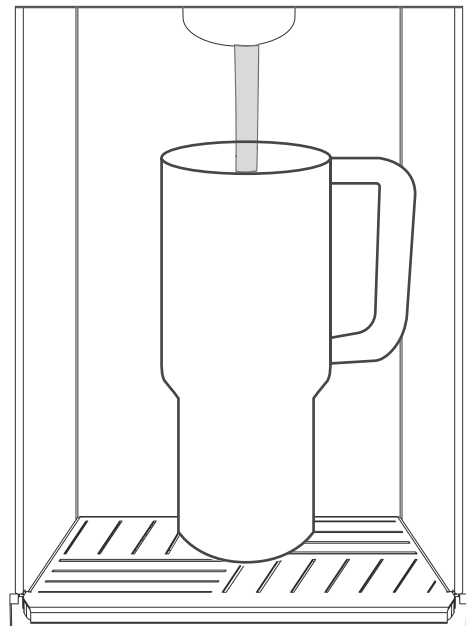
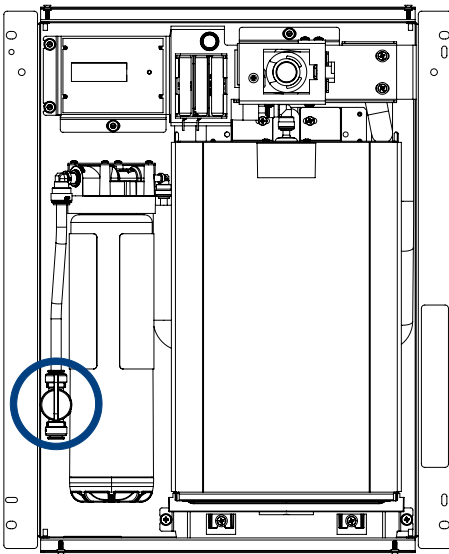

Follow startup instructions on the next page to start enjoying your new Liv EZ water dispenser.

3. Check for any water leaks.

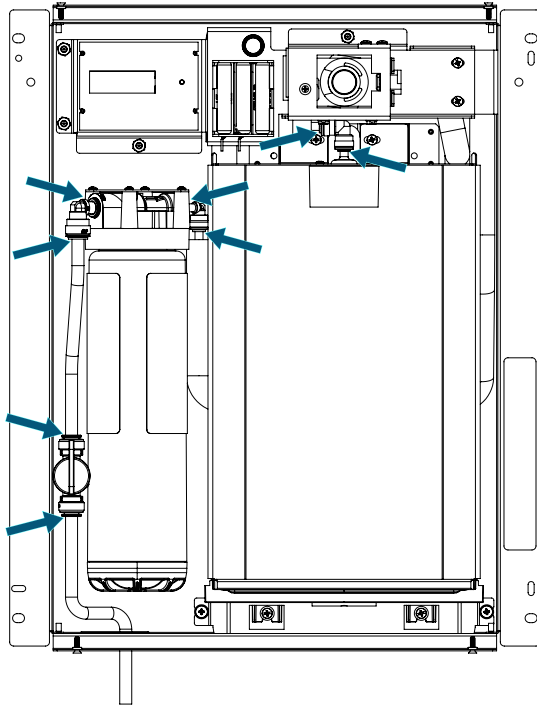

5. Attach the water dispenser glass front cover using the Phillips Head screwdriver and (4) included Phillips head screws. Your Liv EZ is ready to be used - enjoy!

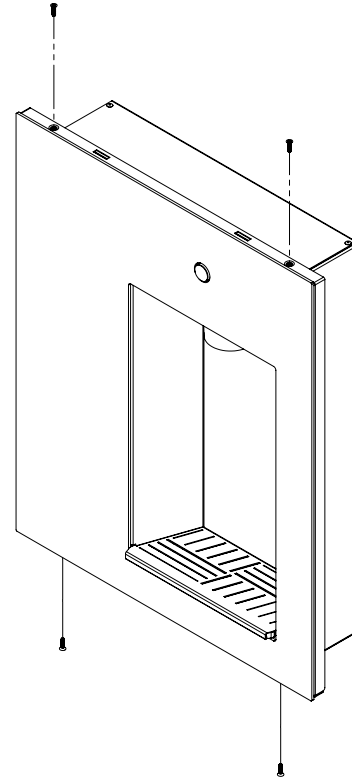

4. Upon initial startup, the Bottles Saved indicator panel will display a number proportionate to the amount of water used during startup.

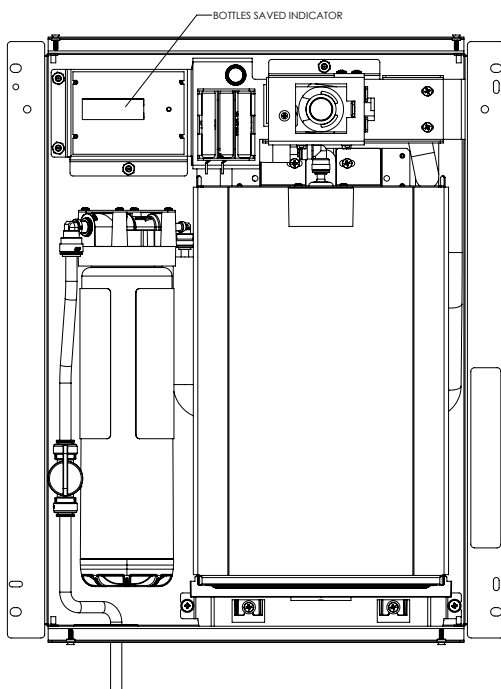

Filter Status Light

The red LED filter status indicator will illuminate during dispense when the life of the filter has reached 91.6% or is depleted and needs to be replaced:

- Pulsing red light: Indicates more than 91.6% of the filter has been used or approximately 11 months of usage
 - LED fades on for two seconds and off for three seconds
- Solid red light: Indicates 100% of the filter has been used or approximately 12 months of usage. Filter must be replaced
 - LED remains lit for the duration of dispense
 - When unit is inactive, LED blinks twice, pauses for ten seconds, then blinks twice again. Cycle repeats for 30 minutes until the filter is replaced and the light is reset

Replacing the Filter and Batteries

1. Remove the screws from the top and bottom of the front panel.

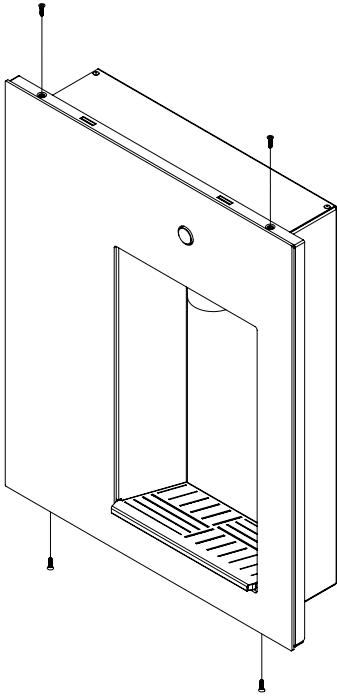

2. Rotate the door gently to loosen it and pull it toward you to remove. Set aside.

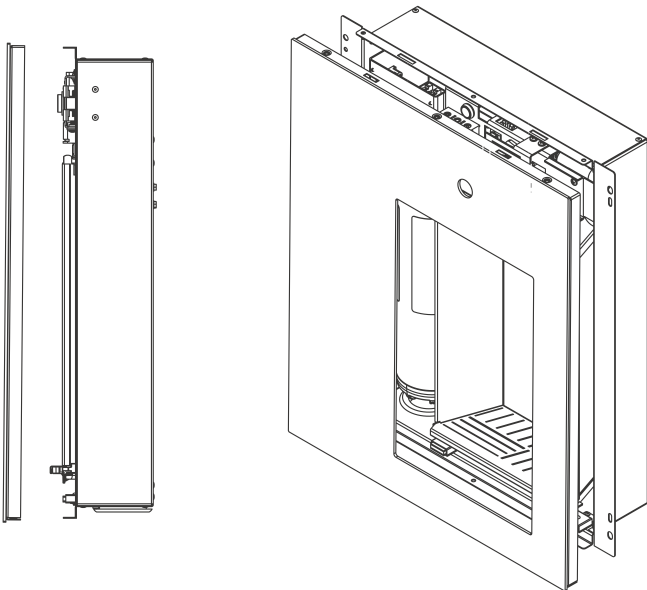

3. Turn off the water supply.

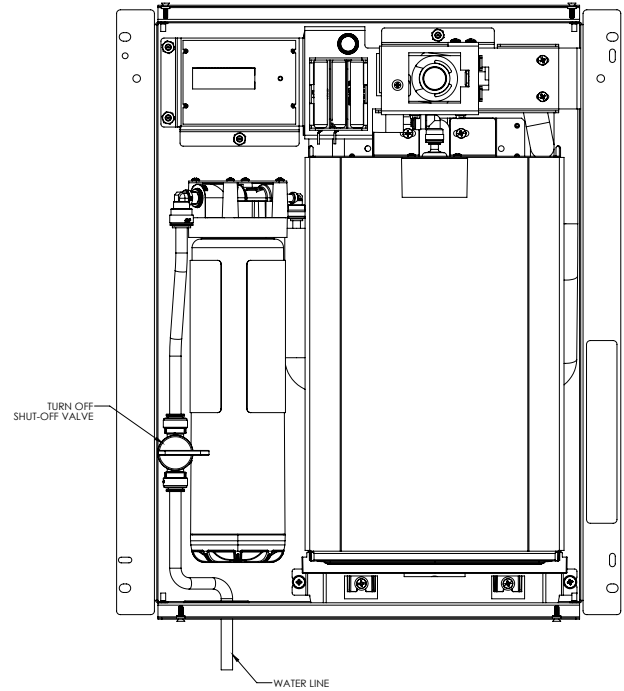

4. Rotate the filter counterclockwise to release it.

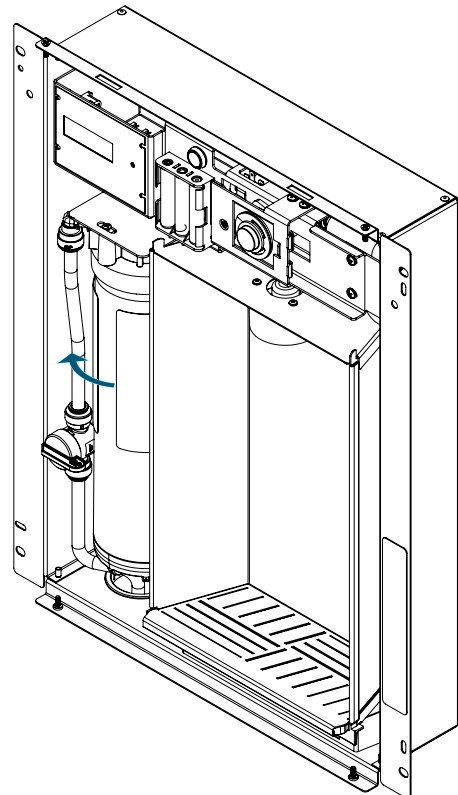

5. Install the new filter by inserting it into the filter head and turning it clockwise to lock in place. Remove existing 3 AAA batteries and replace with new

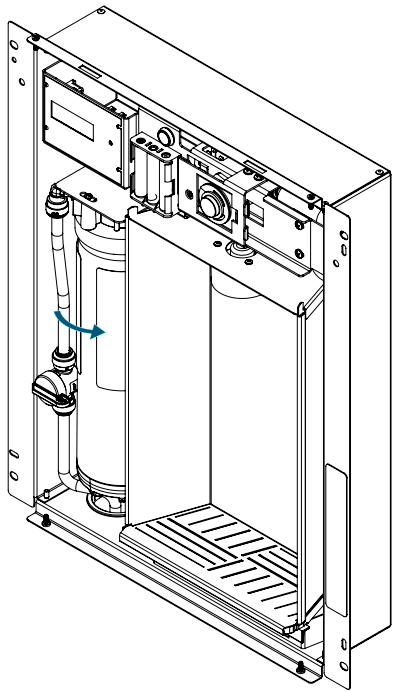

7. Push the reset button to access the menu and reset the filter light.

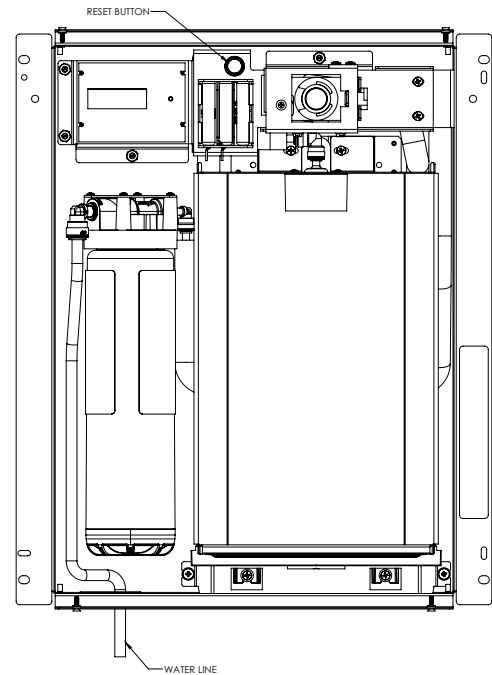

6. Turn on the water supply.

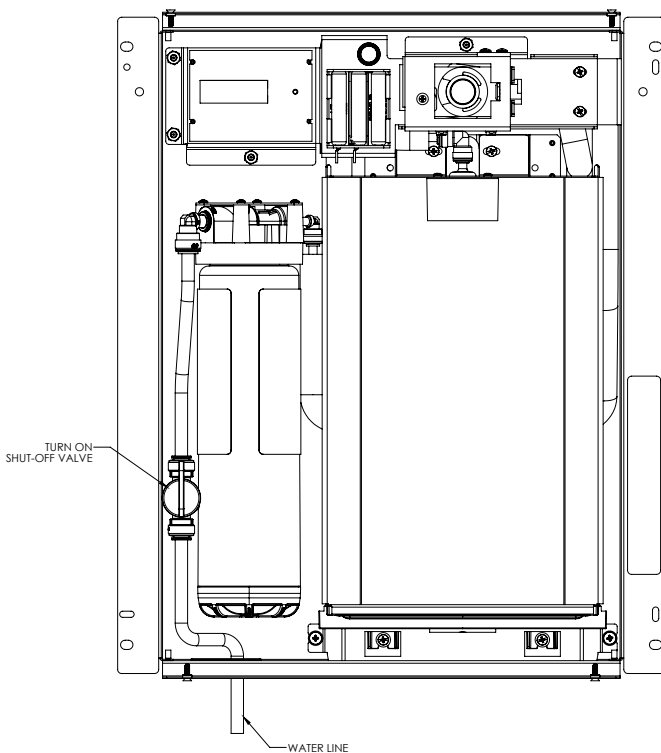

Reset Filter Status Light and Battery Replacement

After replacing the filter, reset the light by pressing the reset button above the battery compartment (p.9).

1. Press and hold the button: HLD 3SEC will appear on the LCD screen.
2. After pressing the button for three seconds, FLTR RST will appear on the screen.
3. Replace batteries and filter once a year.

Scan the QR code or visit elkay.com/products/details/71300C to order replacement filters.



Replacement Parts

Label	Part Number	Description
1	2000002268	Kit - Drain Tray
2	2000002267	Kit - Replacement Glass - Black
3	2000002272	Kit - Replacement Glass - White
4	2000002271	Kit - Replacement Glass - SS
5	2000002270	Kit - Control Board
6	2000002269	Kit - Filter Head and Screws
7	70793C	Elbow 1/4 O.D. X 90
8	2000002275	Kit - Connector & Aerator
9	2000002274	Kit - Alcove
10	1000001673	Kit - 1.0 GPM Regulator Kit
11	2000002036	Battery Box - Liv Harness
12	2000002034	Reset Switch Harness
13	2000002273	Kit - Push Button
14	71300C	PFOA/PFOS + Lead Replacement Filter
15	36333C	Switch - Micro

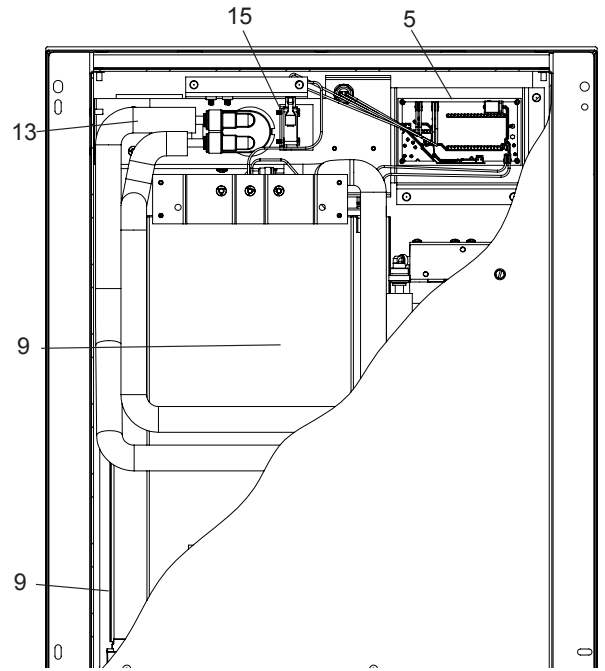

NOTE: Rear view shown with panel cut section

Rear View of Water Dispenser

Fig. 2

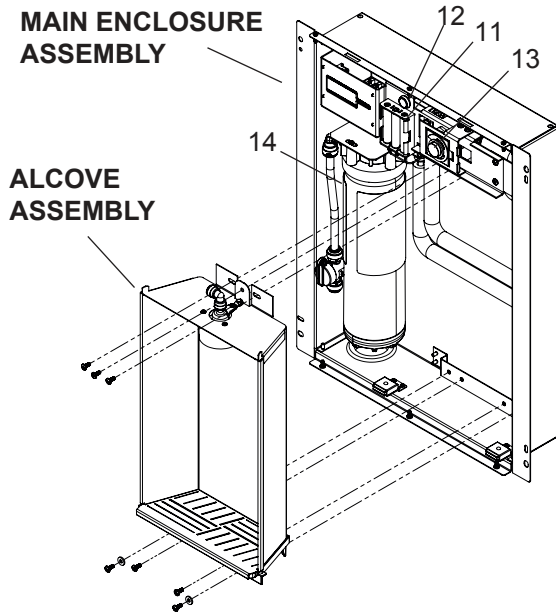
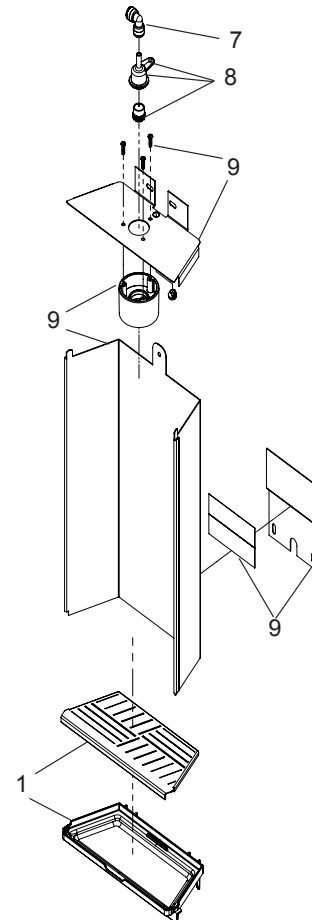

Fig. 1



Alcove Assembly

Fig. 3

Troubleshooting

Issue	Possible Cause	Remedy
Low water flow	Water supply pressure is less than what is required	Water pressure must be between 40 and 105 psi
	Filter is unplugged	Replace filter
No water flow	Water shut-off valve(s) are closed	Open all shut-off valves (one is located inside the filter box if filter is installed, and another may be located at the water source)
	Blocked or damaged water line	Locate affected line and remove blockage or damage

For installation help, scan the QR code or visit youtu.be/_sKmSkYLj3Q to watch our installation video.



Find frequently asked questions at elkay.com/liv

ELKAY

1333 Butterfield Road, Suite 200 | Downers Grove, IL 60515
630.574.8484 | elkay.com | ©2025 EMC Water LLC