



VAREC 2010B/2020B/3500B SERIES PRESSURE AND VACUUM RELIEF VALVE

INSTRUCTION, OPERATION AND MAINTENANCE MANUAL

Before installation, these instructions must be read carefully and understood.



FIGURE 1. 2010B, 2020B AND 3500B SERIES

DISCLAIMER OF WARRANTIES

The contract between Emerson Automation Solutions (Emerson) and our customer states Emerson entire obligation. The contents of this instruction manual shall not become part of or modify any prior or existing agreement, commitment or relationship between Emerson and our customer. There are no express or implied warranties set out in this instruction manual. The only warranties that apply are those in the existing contract between Emerson and our customer.

The Varec 2010B/2020B/3500B Series pressure and/or vacuum relief valve has not been tested by Emerson under all possible operational conditions and Emerson does not have all the data relative to your application. The information in this instruction manual is not all inclusive and does not and cannot take into account all unique situations. Consequently, you should review this product literature in view of your application. If you have any further questions, please contact Emerson for assistance.

LIMITATIONS OF SELLER'S LIABILITY

If it is determined that this instruction manual created some new warranties, Emerson liability shall be limited to repair or replacement under the standard warranty clause. In no case shall Emerson liability exceed that stated as Limitations of Remedy in the contract between Emerson and our customer.

GENERAL INFORMATION

The 2010B/2020B/3500B Series pressure and/or vacuum relief valves are designed to protect low pressure storage tanks, sludge digesters and gas holders from excessive pressure and/or vacuum. The valve is installed on the storage tank roof or digester cover. It may be used in combination with a flame arrester.

The 2010B Series valve relieves pressure directly to the atmosphere. A weatherhood and mesh screen protect the pressure pallet and guideposts. Vacuum pressure is relieved by inbreathing ambient air.

The 2020B Series valve relieves pressure through an enclosed outlet adapter. Product vapors may be piped away rather than relieving directly to the atmosphere. Vacuum pressure is relieved by inbreathing ambient air.

The 3500B Series valve is a vacuum relief valve that relieves negative pressure by inbreathing ambient air.

SAFETY PRECAUTIONS

Read and understand this instruction manual before installing, operating or performing maintenance on 2010B/2020B/3500B Series pressure and/or vacuum relief valve. Follow all precautions and warnings noted herein when installing, operating or performing maintenance on this equipment.

WARNING

Relief valve must be isolated from tank pressure before servicing. All gas must be blocked and pressure safely vented.

Safety precaution definitions

CAUTION

Damage to equipment may result if this precaution is disregarded.

WARNING

Direct injury to personnel or damage to equipment which can cause injury to personnel may result if this precaution is not followed.

TABLE OF CONTENTS

Disclaimer of Warranties	1
Limitations of Seller's Liability	1
General Information	1
Safety Precautions	1
Product Identification and Marking	2
Construction	2
Operation	4
Installation.....	5
Maintenance	6
Calibration	7
Dimensions and Weight	8
Replacement Parts.....	13

VAREC 2010B/2020B/3500B SERIES PRESSURE AND VACUUM RELIEF VALVE

INSTRUCTION, OPERATION AND MAINTENANCE MANUAL

PRODUCT IDENTIFICATION AND MARKING

Hazardous Locations

The 2010B/2020B Series pressure and vacuum relief valves (PVRVs) are available with outer housings of Carbon steel, Stainless steel or Aluminum as indicated.

 **II 1 G c T6** Outer Housing of Stainless steel, Carbon steel or Coated Aluminum

 **II 2 G c T6** Outer Housing of Uncoated Aluminum

Nameplate

The nameplate is attached to the valve, and contains the following information.

1. Connection Size (Size)
2. Serial Number (S/N)
3. Model Number (P/N) per Construction Table
4. Pressure Setting and Air Flow (2010B/2020B Series only)
5. Vacuum Setting and Air Flow
6. Notified Body Number
7. Category Number (**II 1 G c T6** or **II 2 G c T6**, as applicable)
8. Certificate Number

CONSTRUCTION

Standard materials of construction include cast body and cover(s). Pallets are dead weight loaded with lead or steel weights and include a flexible membrane sealing insert. The pallet is loosely guided through a center stem and pallet guide posts.

The "All-Weather" Models 2011B, 2021B and 3501B include a special coating on portions of the pallets, seat rings and guides to eliminate ice accumulation.

TABLE 1 - 2010B/2020B SERIES CONFIGURATION

Code	Type
20	Pressure /Vacuum Relief Valve
Code	Pressure Outlet
1	Vent to Atmosphere
2	Pipe Away
Code	Configuration
0B	Standard
1B	All Weather Type
Code	Size
2	2"
3	3"
4	4"
6	6"
8	8"
0	10"
1	12"
Code	Body/Trim Material
1	Aluminum/Aluminum
2	Aluminum/316 Stainless steel
3	Steel/316 Stainless steel
4	316 Stainless steel/316 Stainless steel
7	Steel/316 Stainless steel with TFE Coated Aluminum Vacuum Pallet Assembly
8	316 Stainless steel/316 Stainless steel with TFE Coated Aluminum Vacuum Pallet Assembly
Code	Insert Material
T	Fluorinated Ethylene Propylene (FEP)
B	Nitrile (NBR)
V	Fluorocarbon (FKM)
Code	Flange Drilling
F	150# ANSI Drilling (Fractional Studs)
M	150# ANSI Drilling (Metric Studs)
D	PN 16 DIN Drilling (Metric Studs)
Code	Flange Face
F	Flat Face Flange
R	Raised Face Flange (Not Available with Aluminum)
Code	Gasket/O-ring Material
O	Standard
B	Nitrile (NBR)
T	Polytetrafluoroethylene (PTFE)
V	Fluorocarbon (FKM)
Code	Retainer/Screen Material
P	Plastic
S	Stainless Steel
Code	Pressure/Vacuum Setting Ranges
0202	Low/Low
0204	Low/High
0402	High/Low
0404	High/High

NOTE

Materials for the 2010B/2020B Series valves are as indicated by the full 16-character model number as shown above.

VAREC 2010B/2020B/3500B SERIES PRESSURE AND VACUUM RELIEF VALVE

INSTRUCTION, OPERATION AND MAINTENANCE MANUAL

TABLE 2 - 3500B SERIES CONFIGURATION

Code	Type
350	Vacuum Relief Valve
Code	Configuration
0B	Standard
1B	All Weather Type
Code	Size
2	2"
3	3"
4	4"
6	6"
8	8"
0	10"
1	12"
Code	Body/Trim Material
1	Aluminum/Aluminum
2	Aluminum/316 Stainless steel
3	Steel/316 Stainless steel
4	316 Stainless steel/316 Stainless steel
7	Steel/316 Stainless steel with TFE Coated Aluminum Vacuum Pallet Assembly
8	316 Stainless steel/316 Stainless steel with TFE Coated Aluminum Vacuum Pallet Assembly
Code	Insert Material
T	Fluorinated Ethylene Propylene (FEP)
B	Nitrile (NBR)
V	Fluorocarbon (FKM)
Code	Flange Drilling
F	150# ANSI Drilling (Fractional Studs)
M	150# ANSI Drilling (Metric Studs)
D	PN 16 DIN Drilling (Metric Studs)
Code	Flange Face
F	Flat Face Flange
R	Raised Face Flange (Not Available with Aluminum)
Code	Gasket/O-ring Material
O	Standard
B	Nitrile (NBR)
T	Polytetrafluoroethylene (PTFE)
V	Fluorocarbon (FKM)
Code	Retainer/Screen Material
P	Plastic
S	Stainless Steel
Code	Vacuum Setting Ranges
02	Low
04	High

NOTE

Materials for the 3500B Series valves are as indicated by the full 14-character model number as shown above.

VAREC 2010B/2020B/3500B SERIES PRESSURE AND VACUUM RELIEF VALVE

INSTRUCTION, OPERATION AND MAINTENANCE MANUAL

OPERATION

2010B/2020B Series pressure relief valves

When the internal tank pressure approaches the valve setting, the pressure pallet begins to lift. As the pressure exceeds the valve setting, the pressure pallet lifts off the seat ring. Excess product vapor is allowed to vent to the atmosphere or through the pipe away system adapter, relieving the over pressure condition. The pallet automatically re-seats as the tank pressure drops below the valve setting.

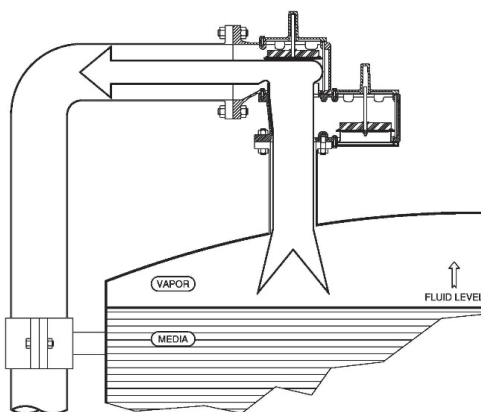

FIGURE 2. PRESSURE CONTROL OPERATION

TABLE 3 - 2010B/2020B SERIES PRESSURE SETTING

Series	Pressure Setting Low Range	Pressure Setting High Range
2010B	0.3 to 16 osig / 1.29 to 68.9 mbarg	16 to 32 osig / 68.9 to 138 mbarg
2020B	0.3 to 16* osig / 1.29 to 68.9* mbarg	16* to 32 osig / 68.9* to 138 mbarg

* 10 osig / 43.1 mbarg for 2" and 3" sizes.

2010B/2020B/3500B Series vacuum relief valves

If a vacuum within the tank approaches the valve setting, the vacuum pallet begins to lift. As the vacuum exceeds the valve setting, the vacuum pallet lifts off the seat ring. Atmospheric air is allowed to flow into the tank, relieving the excess vacuum condition. The pallet automatically re-seats as the vacuum drops below the valve setting.

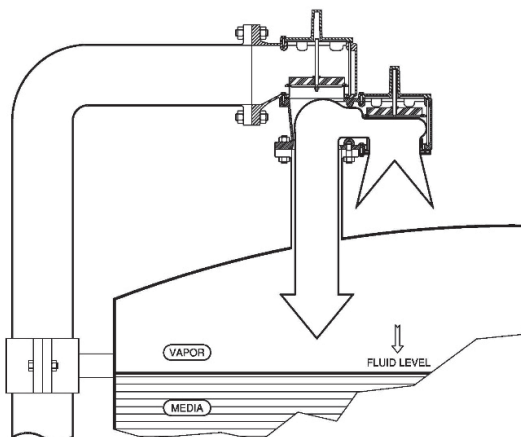

FIGURE 3. VACUUM CONTROL OPERATION

TABLE 4 - 2010B/2020B/3500B SERIES VACUUM SETTING

Series	Vacuum Setting Low Range	Vacuum Setting High Range
2010B	0.3 to 16* osig / 1.29 to 68.9* mbarg	16* to 32 osig / 68.9* to 138 mbarg
2020B	0.3 to 16* osig / 1.29 to 68.9* mbarg	16* to 32 osig / 68.9* to 138 mbarg
3500B	0.3 to 16* osig / 1.29 to 68.9* mbarg	16* to 32 osig / 68.9* to 138 mbarg

* 10 osig / 43.1 mbarg for 2" and 3" sizes.

VAREC 2010B/2020B/3500B SERIES PRESSURE AND VACUUM RELIEF VALVE

INSTRUCTION, OPERATION AND MAINTENANCE MANUAL

INSTALLATION (PLACING INTO SERVICE)

2010B/2020B/3500B Series pressure and vacuum relief valves must be mated with the appropriate flange(s). The nozzle must be plumb and the inlet flange face level to ensure proper operation of the relief valve.

1. Remove the valve from the shipping container. Check to see if extra loading weights were bagged and packed separately.
2. Remove the weatherhood and/or cover(s) and all packing material above the pallets and within the valve.

CAUTION

Whenever the weatherhood and/or cover(s) is removed and reinstalled, the end of the pallet stem must engage the stem guide in the weatherhood and/or the stem guide chamber in the cover(s) for proper seating and valve operation.

3. To load vacuum pallet weights, perform the following:
 - a. With vacuum cover and gasket removed, remove vacuum pallet assembly from body.
 - b. Remove grip ring from pallet stem.
 - c. Non-variable setting: locate weight marked "VACUUM" and place on top of compensating weight and/or pallet. Secure with grip ring.
Note: if setting is less than 2" WC, weight will be pre-loaded on the pallet.
 - d. Variable setting: each lead weight is calibrated from 1" WC increment. (Increments of ¼" WC and ½" WC may be supplied on special order). Those weights necessary for the initial specified setting will be tagged separately from any extra weight provided. Remove the packaging on the weights tagged from the initial specified setting and place the weights on top of the compensating weight. Secure with grip ring. Store remaining weights for future use (in case the setting needs to be increased).
 - e. Weigh entire pallet assembly (including installed weights). Using Table 5, confirm that the assembly is the proper weight to achieve the required setting. Allowable weight tolerance is +5%, -5%.
 - f. Remove any remaining packing material from valve body. Wipe vacuum seat ring, guide posts and pallet assembly with a soft cloth to remove any material which could affect valve operation.

- g. Place pallet assembly on valve body seat. Ensure that pallet moves freely within guide posts and rests flat on the seat ring.
- h. Replace the cover gasket and cover. Tighten cover screws uniformly.

CAUTION

The end of the pallet stem must engage the stem guide chamber in the cover for proper seating and valve operation.

4. To load pressure pallet weights, perform the following:
 - a. With weatherhood from Model 2010B, or pipe away adapter cover and gasket from Model 2020B removed, remove pressure pallet assembly from body.
 - b. Remove grip ring from pallet stem.
 - c. Non-variable setting: locate weight marked "PRESSURE" and place on top of compensating weight and/or pallet. Secure with grip ring. If setting is less than 2" WC, weight will be pre-loaded on the pallet.
 - d. Variable setting: each lead weight is calibrated from 1" WC increment. (Increments of ¼" WC and ½" WC may be supplied on special order). Those weights necessary for the initial specified setting will be tagged separately from any extra weight provided. Remove the packaging on the weights tagged from the initial specified setting and place the weights on top of the compensating weight. Secure with grip ring. Store remaining weights for future use (in case the setting needs to be increased).
 - e. Weigh entire pallet assembly (including installed weights). Using Table 5, confirm that the assembly is the proper weight to achieve the required setting. Allowable weight tolerance is +5%, -5%.
 - f. Remove any remaining packing material from valve body. Wipe pressure seat ring, guide posts and pallet assembly with a soft cloth to remove any material which could affect valve operation.

- g. Place pallet assembly on seat. Ensure that pallet moves freely within guide posts and rests flat on the seat ring.
- h. Replace the weatherhood on Model 2010B or the pressure cover and gasket on Model 2020B. Tighten all nuts and screws uniformly.

CAUTION

The end of the pallet stem must engage the stem guide in the weatherhood or the stem guide chamber in the cover for proper seating and valve operation.

5. Place the valve in a level position. Reach up through the inlet flange and carefully push up on the pressure pallet, then lower it onto the seat. Pallet should move up and down freely and rest flat on the seat ring.
6. Check the vacuum pallet by using a non-sparking tool which will pass through the center of the mesh screen. Push up on the vacuum pallet, then lower it onto the seat. Pallet should move freely and rest flat on the seat ring.
7. Mount the valve on the flanged nozzle or flame arrester using the appropriate full faced gasket.

CAUTION

DO NOT MATE A FLAT FACE FLANGE TO A RAISED FACE FLANGE.

If it necessary to mate an ANSI Class 125 F.F. Flange with an ANSI Class 150 R.F. Flange, use the proper spacer to convert the raised face to a flat face.

8. Verify that the valve is level to permit proper operation of the pallets. Install mounting hardware, and tighten uniformly.
9. When using Model 2020B Series, install connecting piping (if required) to outlet flange. Use a full faced gasket and tighten all mounting hardware uniformly.

NOTE

It is recommended that steel and iron valves be given a coat of paint immediately after installation is completed. Apply paint to external surfaces only.

VAREC 2010B/2020B/3500B SERIES PRESSURE AND VACUUM RELIEF VALVE

INSTRUCTION, OPERATION AND MAINTENANCE MANUAL

MAINTENANCE (ASSEMBLING AND DISMANTLING)

The valve should be inspected and cleaned at periodic intervals. The first inspection should be made approximately 30 days after commissioning. Subsequent inspections should be made every 30 days. The user may adjust the schedule for his own convenience and safety, depending upon the product being stored.

WARNING

- Relief valve must be isolated from tank pressure before servicing. All gas must be blocked and pressure safely vented. If no isolation valve is present, carefully open vacuum cover or lift pressure pallet, allowing pressure to vent slowly.
- Wear appropriate gloves and/or breathing apparatus if hazardous vapors are present.

1. To inspect valve proceed as follows:
 - a. Remove the weatherhood and/or cover(s).
 - b. Remove pallets one at a time. Identify the pallets to ensure they are returned to the correct valve seat.
 - c. Inspect pallet inserts for ripples, tears, or nicks, as well as seating surfaces for debris, abrasion or pitting. Pallet edges and guide posts should be free of burrs, corrosion or other obvious damage. Clean all components, replacing any showing excess wear or damage. On the "All-Weather" versions, inspect the PTFE coating for any damage that would affect operation.
 - d. Reassemble in reverse order.

CAUTION

The end of the pallet stem must engage the stem guide in the weatherhood and/or the stem guide chamber in the cover(s) for proper seating and valve operation.

CAUTION

During periods of freezing weather, extra maintenance is required for 2010B/2020B/3500B Series. Either remove the pallets or apply generous portions of silicone grease to the pallets, seat rings and guide posts. When using silicone grease, inspect valves at least weekly. This procedure is not required for "All-Weather" Models 2011B, 2021B or 3501B.

2. To replace pallet insert proceed as follows:
 - a. Remove weatherhood and/or cover(s) and then pallet assembly.
 - b. Remove nut from base of pallet stem. Remove retainer plate and insert. Clean all surfaces and threads. Install new insert, handling carefully to avoid damaging insert or pallet.
 - c. Reassemble pallet and place on seat of valve body. Ensure pallet assembly moves freely within guide posts and rests flat on seat ring.
 - d. Reinstall weatherhood and/or cover(s).

CAUTION

The end of the pallet stem must engage the stem guide in the weatherhood and/or the stem guide chamber in the cover(s) for proper seating and valve operation.

3. To replace pressure seat ring perform the following:
 - a. For Model 2010B, remove weatherhood, screen, spacer ring, pallet assembly and guide posts. For Model 2020B, remove pressure cover, spacer (high setting), gaskets, pallet assembly, outlet adapter, and guide posts.
 - b. Remove seat ring and O-Ring from valve body. Clean body, outlet adapter mating surfaces and O-Ring Groove.
 - c. Install new O-Ring into groove; insure that the O-Ring stays properly in groove while installing seat ring.
 - d. Install new seat ring carefully to avoid distortion. Reassemble guide posts (Model 2010B) or outlet adapter (Model 2020B) to secure seat. Ensure that seat is flush and level with valve body.
 - e. Reassemble guide posts (Model 2020B).
 - f. Place pallet assembly on valve body seat. Ensure pallet assembly moves freely within guide posts and rest flat on seat ring.
 - g. Reassemble remaining parts in reverse order.

CAUTION

The end of the pallet stem must engage the stem guide in the weatherhood and/or the stem guide chamber in the cover(s) for proper seating and valve operation.

4. To replace vacuum seat ring perform the following:
 - a. Remove vacuum cover, spacer (high setting), gaskets, pallet assembly, screen retainer, screen and guide posts.
 - b. Remove seat ring and O-Ring from valve body. Clean body mating surface and O-Ring groove.
 - c. Install new O-Ring into groove; insure that the O-Ring stays properly in groove while installing seat ring.
 - d. Install new seat ring carefully to avoid distortion. Reassemble screen and retaining ring to secure seat ring. Ensure that seat is flush and level with valve body.
 - e. Reassemble guide posts.
 - f. Place pallet assembly on valve body seat. Ensure pallet assembly moves freely within guide posts and rests flat on seat ring.
 - g. Reassemble spacer, cover and gaskets.

CAUTION

The end of the pallet stem must engage the stem guide chamber in the cover for proper seating and valve operation.

5. Seat ring repair:
 - a. Seat may be ground or ground and lapped (in place) to improve seal. Use a lapping plate and medium valve grinding compound, applying light pressure.
 - b. Finish lapping with a fine compound. Avoid scoring or removing excessive amounts of material.
 - c. Clean all compound from valve parts.
 - d. Hand buff seat with a medium grade 'Scotch-Brite' (#7447) pad and light oil.

CAUTION

Whenever the weatherhood and/or cover(s) is removed and reinstalled, the end of the pallet stem must engage the stem guide in the weatherhood and/or the stem guide chamber in the cover(s) for proper seating and valve operation.

VAREC 2010B/2020B/3500B SERIES PRESSURE AND VACUUM RELIEF VALVE

INSTRUCTION, OPERATION AND MAINTENANCE MANUAL

CALIBRATION

To verify setting, calculate the total necessary weight using the Table 5. Check this value against the actual weight of the pallet assembly (including loading weights). Adjust loading weights as required.

TABLE 5 - PALLET LOADING (INCLUDES WEIGHT OF PALLET)

Valve size	Ounces of weight required per ounce of setting	Ounces of weight required per inch of WC setting
2"	8.3	4.8
3"	16.8	9.7
4"	22.1	12.8
6"	43.4	25.1
8"	72.7	42.0
10"	120.1	69.4
12"	179.9	104.0

Weight tolerance: + 5%/- 5%
Setting tolerance: + 0%/- 10%

TABLE 6 - MODEL 2010B- LOW SETTING SIZES AND DIMENSIONS

Size	A in. (mm)	B in. (mm)	C in. (mm)	D in. (mm)
2"	14 ¹ / ₈ (359)	8 ¹ / ₂ (216)	9 ⁷ / ₈ (251)	10 ⁷ / ₁₆ (265)
3"	17 ⁷ / ₁₆ (446)	10 ³ / ₄ (273)	12 ¹ / ₄ (311)	12 ⁹ / ₁₆ (313)
4"	19 ¹ / ₈ (486)	13 ³ / ₈ (340)	12 ⁷ / ₁₆ (316)	14 ⁷ / ₁₆ (370)
6"	24 (610)	17 (432)	15 ⁹ / ₁₆ (395)	18 ¹ / ₄ (464)
8"	29 ⁷ / ₈ (759)	20 ⁵ / ₈ (524)	19 ⁷ / ₁₆ (497)	21 ³ / ₄ (552)
10"	38 ⁷ / ₁₆ (976)	27 (686)	24 ¹⁵ / ₁₆ (633)	27 ⁹ / ₁₆ (700)
12"	46 ³ / ₈ (1178)	34 (864)	29 ³ / ₈ (746)	32 ¹⁵ / ₁₆ (837)

FIGURE 4 - MODEL 2010B LOW SETTING
Drilling per ANSI Class 125 F.F.

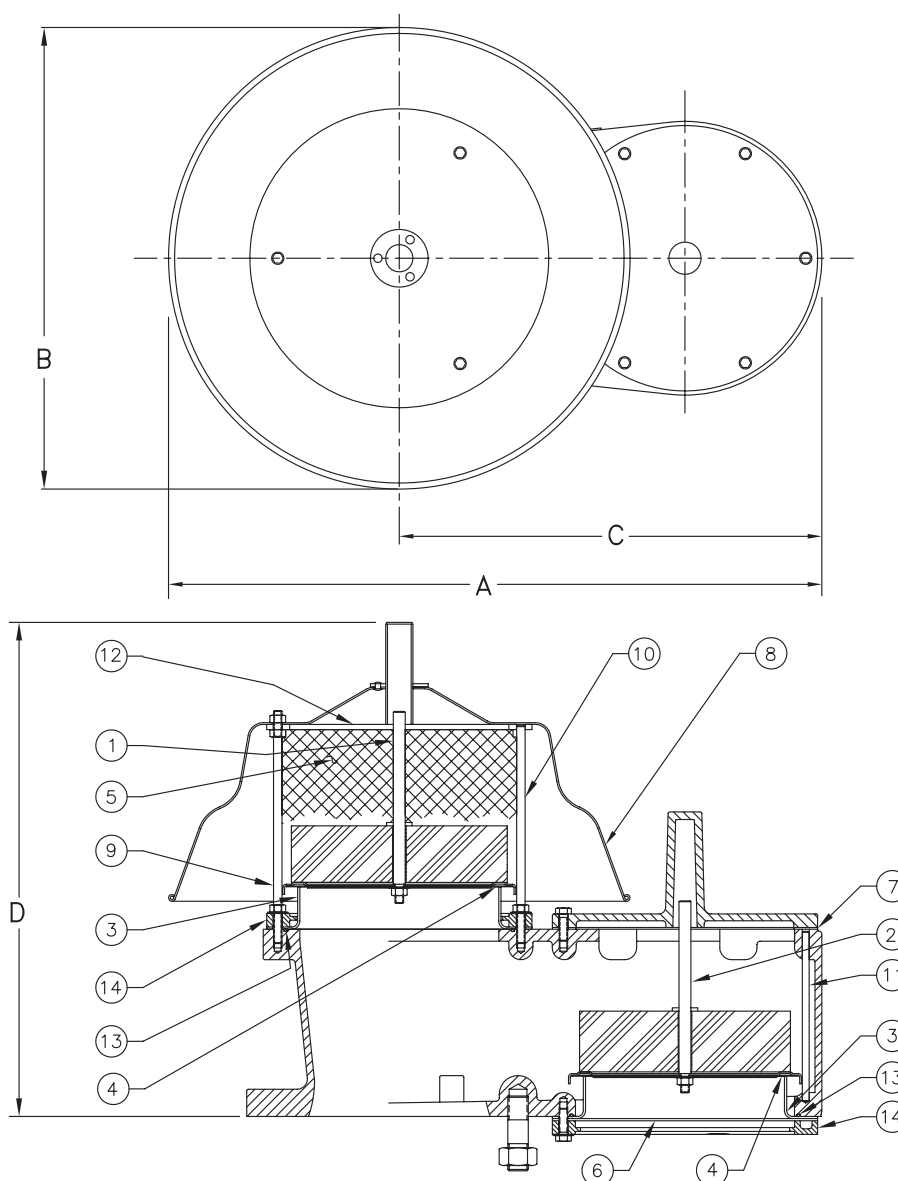

VAREC 2010B/2020B/3500B SERIES PRESSURE AND VACUUM RELIEF VALVE

INSTRUCTION, OPERATION AND MAINTENANCE MANUAL

FIGURE 5 - MODEL 2010B HIGH SETTING
Drilling per ANSI Class 125 F.F.

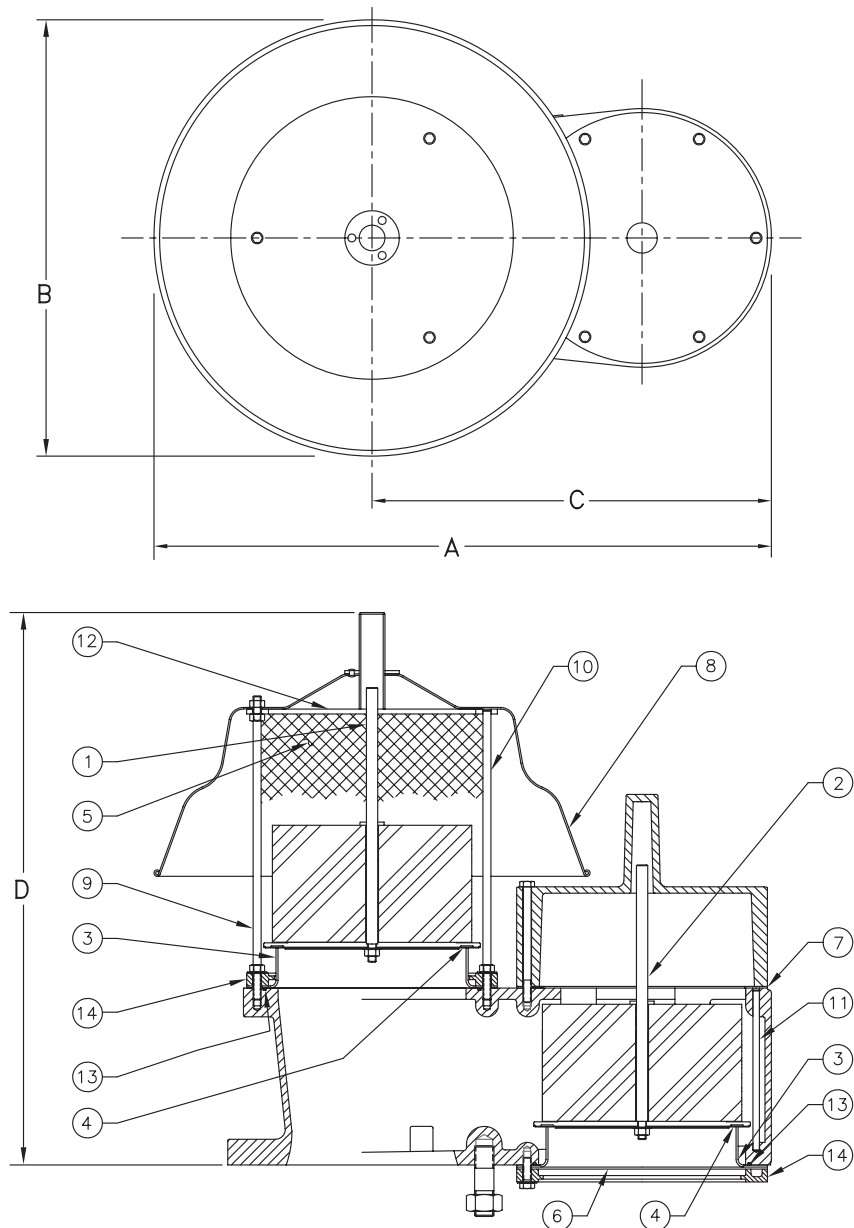

TABLE 7 - MODEL 2010B- HIGH SETTING SIZES AND DIMENSIONS

Size	A in. (mm)	B in. (mm)	C in. (mm)	D in. (mm)
2"	14 ¹ / ₈ (359)	8 ¹ / ₂ (216)	9 ⁷ / ₈ (251)	13 ⁷ / ₁₆ (338)
3"	17 ⁷ / ₁₆ (446)	10 ³ / ₄ (273)	12 ¹ / ₄ (311)	15 ¹ / ₄ (387)
4"	19 ¹ / ₈ (486)	13 ³ / ₈ (340)	12 ⁷ / ₁₆ (316)	17 ¹ / ₄ (438)
6"	24 (610)	17 (432)	15 ⁷ / ₁₆ (395)	21 ⁷ / ₁₆ (548)
8"	29 ⁷ / ₈ (759)	20 ⁷ / ₈ (524)	19 ⁷ / ₁₆ (497)	24 ¹³ / ₁₆ (630)
10"	38 ⁷ / ₁₆ (976)	27 (686)	24 ¹⁵ / ₁₆ (633)	29 ¹ / ₂ (749)
12"	46 ³ / ₈ (1178)	34 (864)	29 ³ / ₈ (746)	32 ¹⁵ / ₁₆ (837)

VAREC 2010B/2020B/3500B SERIES PRESSURE AND VACUUM RELIEF VALVE

INSTRUCTION, OPERATION AND MAINTENANCE MANUAL

FIGURE 6 - MODEL 2020B LOW SETTING
Drilling per ANSI Class 125 F.F.

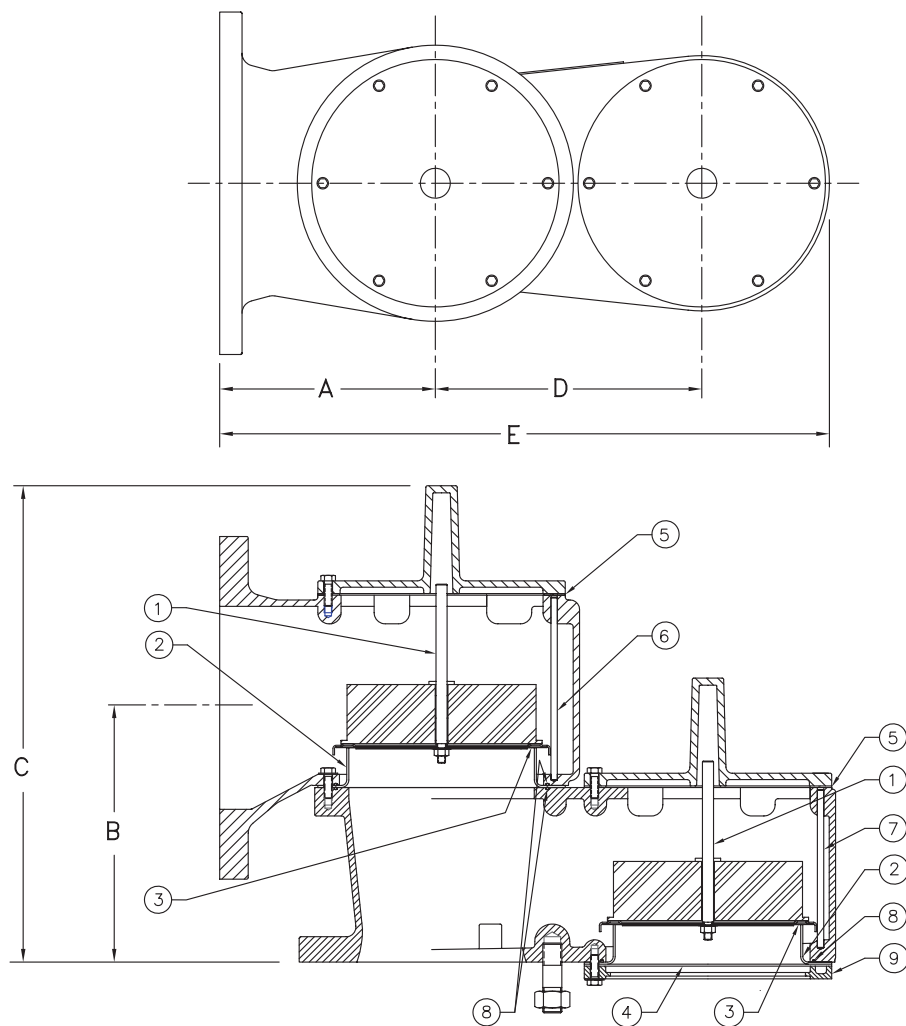

TABLE 8 - MODEL 2020B- LOW SETTING SIZES AND DIMENSIONS

Size Inlet	Outlet	A in. (mm)	B in. (mm)	C in. (mm)	D in. (mm)	E in. (mm)
2"	3"	4 ¹⁵ / ₁₆ (125)	5 ¹ / ₄ (133)	9 ¹ / ₁₆ (230)	6 ³ / ₄ (171)	14 ³ / ₄ (375)
3"	4"	6 ³ / ₈ (162)	5 ⁷ / ₈ (149)	10 ¹³ / ₁₆ (275)	8 ³ / ₈ (213)	18 ⁷ / ₁₆ (471)
4"	6"	8 (203)	6 ¹³ / ₁₆ (173)	12 ¹³ / ₁₆ (325)	8 ⁷ / ₁₆ (214)	20 ⁷ / ₁₆ (519)
6"	8"	8 ³ / ₄ (222)	10 (254)	18 ¹³ / ₁₆ (478)	10 ¹ / ₂ (267)	24 ¹ / ₄ (616)
8"	10"	11 ³ / ₁₆ (284)	12 ¹ / ₈ (308)	22 ¹ / ₈ (562)	13 ¹ / ₈ (333)	30 ³ / ₄ (781)
10"	12"	13 ⁵ / ₈ (346)	16 ¹ / ₄ (413)	27 ⁷ / ₁₆ (700)	16 ⁷ / ₈ (429)	38 ⁷ / ₁₆ (979)
12"	14"	15 ⁵ / ₈ (391)	18 ⁷ / ₈ (480)	32 ¹ / ₁₆ (814)	19 ³ / ₄ (502)	44 ³ / ₄ (1137)

VAREC 2010B/2020B/3500B SERIES PRESSURE AND VACUUM RELIEF VALVE

INSTRUCTION, OPERATION AND MAINTENANCE MANUAL

FIGURE 7 - MODEL 2020B HIGH SETTING
Drilling per ANSI Class 125 F.F.

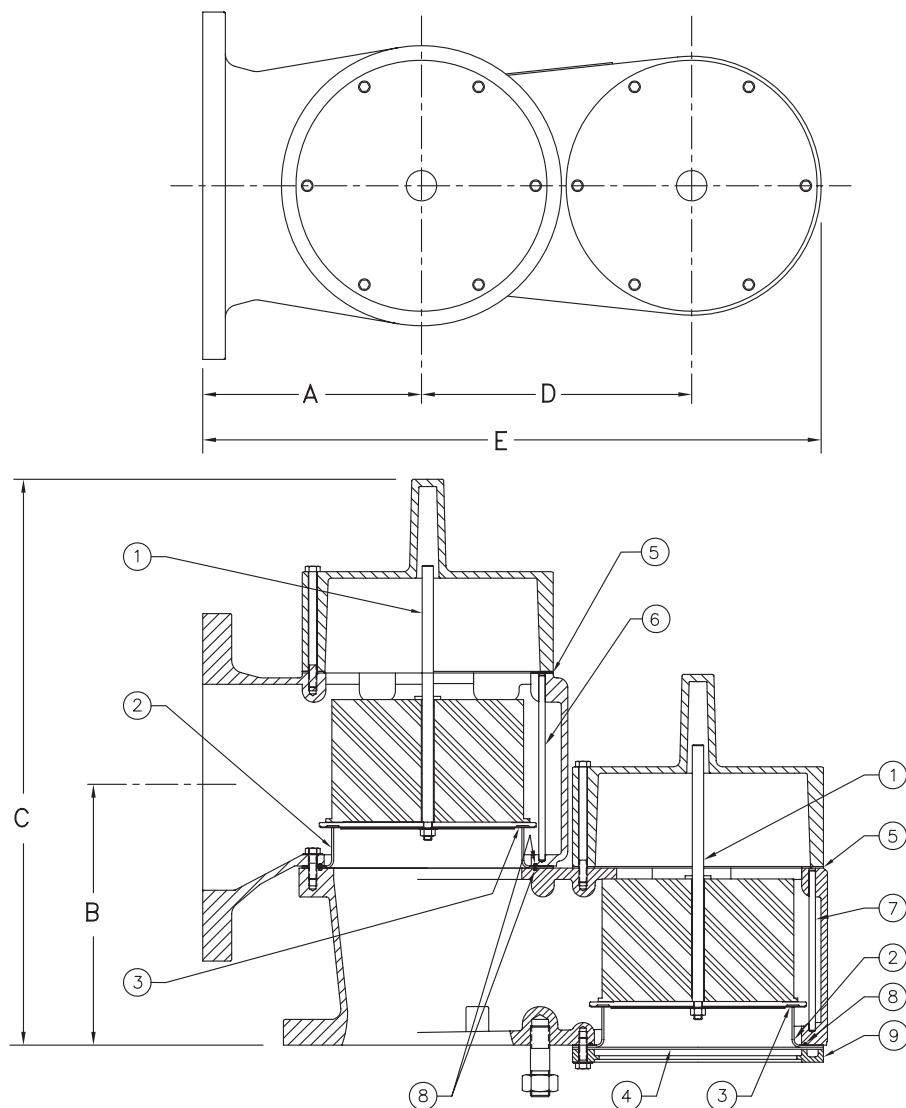

TABLE 9 - MODEL 2020B- HIGH SETTING SIZES AND DIMENSIONS

Size		A in.	B in.	C in.	D in.	E in.
Inlet	Outlet	(mm)	(mm)	(mm)	(mm)	(mm)
2"	3"	4 ¹⁵ / ₁₆ (125)	5 ¹ / ₄ (133)	13 ³ / ₈ (346)	6 ³ / ₄ (171)	14 ³ / ₄ (375)
3"	4"	6 ³ / ₈ (162)	5 ⁷ / ₈ (149)	15 ⁵ / ₁₆ (395)	8 ³ / ₈ (213)	18 ⁷ / ₁₆ (471)
4"	6"	8 (203)	6 ¹³ / ₁₆ (173)	16 ⁷ / ₈ (429)	8 ⁷ / ₁₆ (214)	20 ⁷ / ₁₆ (519)
6"	8"	8 ³ / ₄ (222)	10 (254)	22 ¹ / ₁₆ (560)	10 ¹ / ₂ (267)	24 ¹ / ₄ (616)
8"	10"	11 ³ / ₁₆ (284)	12 ¹ / ₈ (308)	24 ⁹ / ₈ (625)	13 ¹ / ₈ (333)	30 ³ / ₄ (781)
10"	12"	13 ³ / ₈ (346)	16 ¹ / ₄ (413)	29 ⁵ / ₁₆ (744)	16 ⁷ / ₈ (429)	38 ⁷ / ₁₆ (979)
12"	14"	15 ³ / ₈ (391)	18 ⁷ / ₈ (480)	32 ¹ / ₁₆ (814)	19 ³ / ₄ (502)	44 ³ / ₄ (1137)

VAREC 2010B/2020B/3500B SERIES PRESSURE AND VACUUM RELIEF VALVE

INSTRUCTION, OPERATION AND MAINTENANCE MANUAL

FIGURE 8 - MODEL 3500B LOW SETTING
Drilling per ANSI Class 125 F.F.

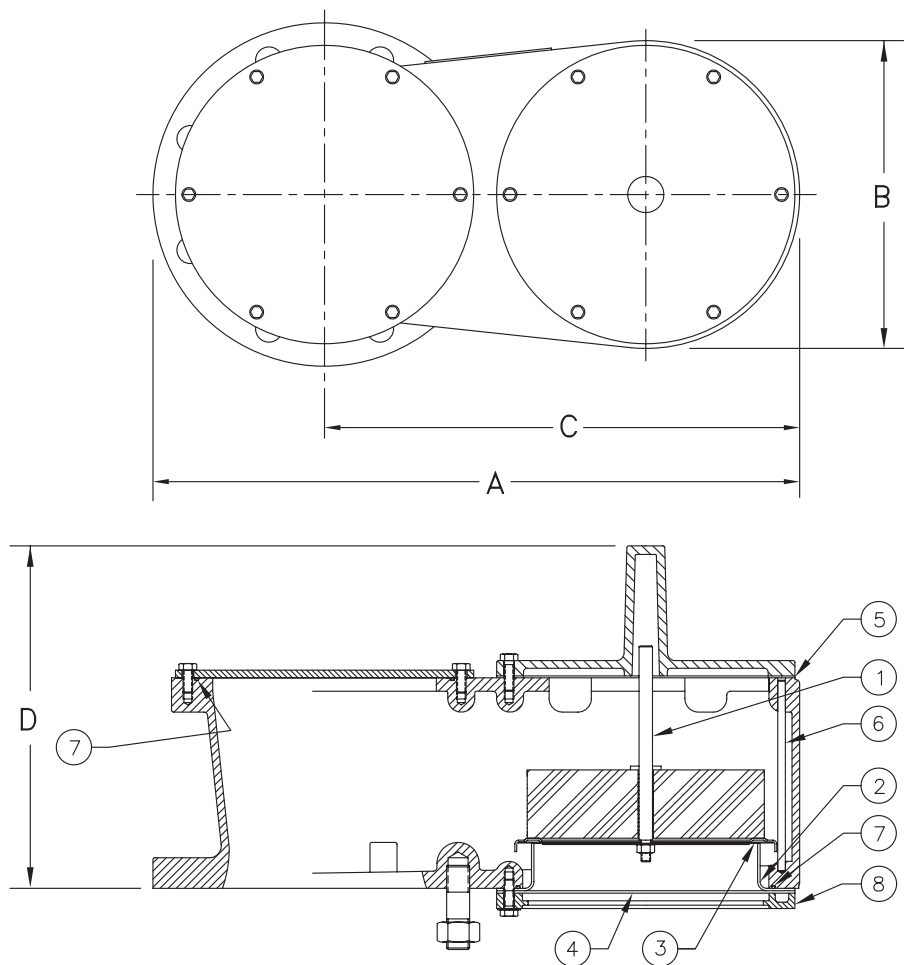

TABLE 10 - MODEL 3500B- LOW SETTING SIZES AND DIMENSIONS

Size	A in. (mm)	B in. (mm)	C in. (mm)	D in. (mm)
2"	13 ¹ / ₈ (333)	6 ³ / ₁₆ (157)	9 ⁷ / ₈ (251)	5 ⁷ / ₁₆ (141)
3"	16 ¹ / ₈ (409)	7 ⁵ / ₈ (194)	12 ¹ / ₄ (311)	6 ⁵ / ₈ (168)
4"	16 ¹⁵ / ₁₆ (430)	8 (203)	12 ⁷ / ₁₆ (316)	7 ⁷ / ₈ (194)
6"	21 ³ / ₁₆ (538)	10 ¹ / ₁₆ (256)	15 ⁵ / ₁₆ (395)	11 ¹ / ₄ (268)
8"	26 ⁵ / ₁₆ (668)	12 ⁷ / ₈ (327)	19 ⁹ / ₁₆ (497)	13 ¹ / ₄ (337)
10"	32 ¹⁵ / ₁₆ (837)	16 ¹ / ₈ (409)	24 ¹⁵ / ₁₆ (633)	16 ¹ / ₈ (409)
12"	38 ⁷ / ₈ (988)	19 ¹ / ₄ (489)	29 ⁹ / ₈ (746)	18 ¹³ / ₁₆ (478)

VAREC 2010B/2020B/3500B SERIES PRESSURE AND VACUUM RELIEF VALVE

INSTRUCTION, OPERATION AND MAINTENANCE MANUAL

FIGURE 9 - MODEL 3500B HIGH SETTING
Drilling per ANSI Class 125 F.F.

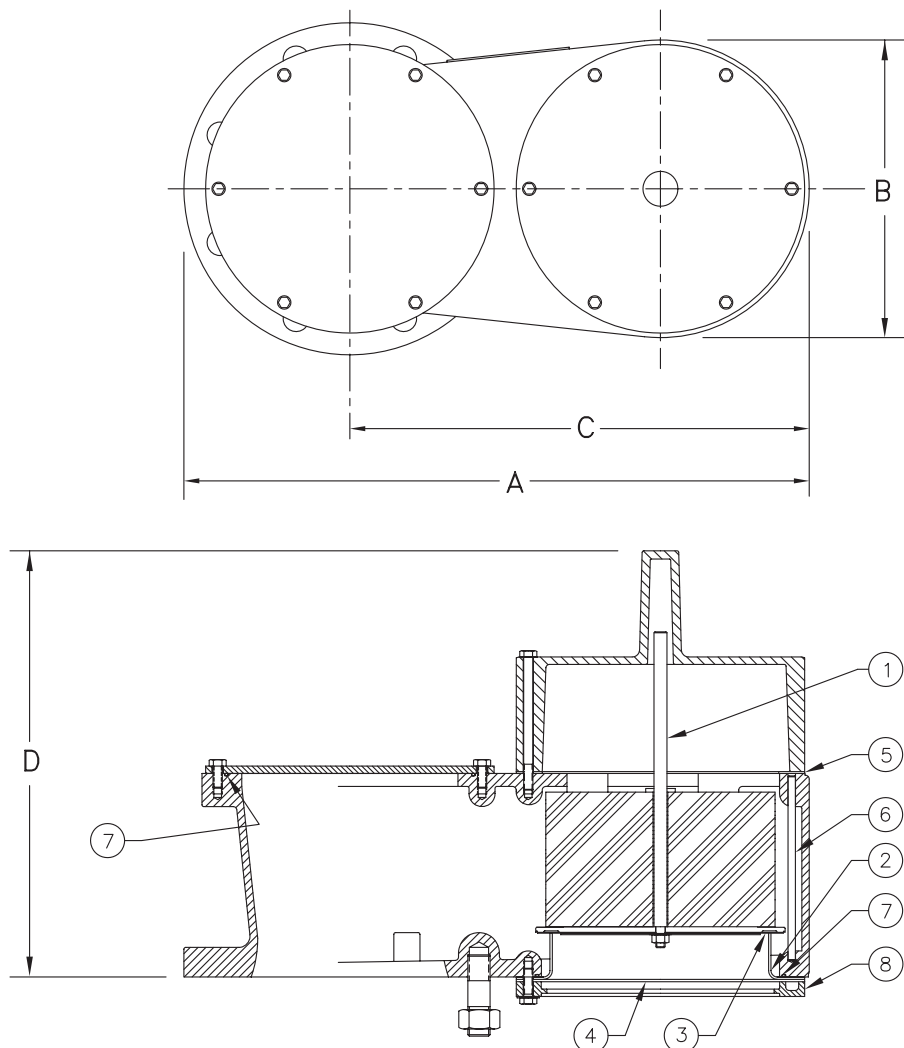

TABLE 11 - MODEL 3500B- HIGH SETTING SIZES AND DIMENSIONS

Size	A in. (mm)	B in. (mm)	C in. (mm)	D in. (mm)
2"	13 ¹ / ₈ (333)	6 ³ / ₁₆ (157)	9 ⁷ / ₈ (251)	10 ¹ / ₁₆ (256)
3"	16 ¹ / ₈ (409)	7 ⁵ / ₈ (194)	12 ¹ / ₄ (311)	11 ³ / ₈ (289)
4"	16 ¹⁵ / ₁₆ (430)	8 (203)	12 ⁷ / ₁₆ (316)	11 ¹¹ / ₁₆ (297)
6"	21 ³ / ₁₆ (538)	10 ¹ / ₁₆ (256)	15 ⁵ / ₁₆ (395)	14 ¹ / ₂ (368)
8"	26 ⁵ / ₁₆ (668)	12 ⁷ / ₈ (327)	19 ⁹ / ₁₆ (497)	15 ¹¹ / ₁₆ (398)
10"	32 ¹⁵ / ₁₆ (837)	16 ¹ / ₈ (409)	24 ¹⁵ / ₁₆ (633)	17 ¹³ / ₁₆ (452)
12"	38 ⁷ / ₈ (988)	19 ¹ / ₄ (489)	29 ⁹ / ₈ (746)	18 ¹³ / ₁₆ (478)

VAREC 2010B/2020B/3500B SERIES PRESSURE AND VACUUM RELIEF VALVE

INSTRUCTION, OPERATION AND MAINTENANCE MANUAL

2010B/2020B/3500B SERIES REPLACEMENT PARTS

When ordering replacement parts, specify relief valve by model number, pipe size and serial number. Identify replacement parts by part number, description and material where possible.

TABLE 12 - REPLACEMENT PARTS MODEL 2010B (SEE FIGURES 4 AND 5)

Item No.	Description	Usage	Material	Nominal pipe size						
				2"	3"	4"	6"	8"	10"	12"
1*	Pressure pallet assembly	Low set	Aluminum	06-11485-301	06-11485-401	06-11485-501	06-11485-601	06-11485-701	06-11485-801	06-11485-901
		High set	Aluminum	06-11486-101	06-11486-201	06-11486-301	06-11486-401	06-11486-501	06-11486-601	06-11486-701
		Low set	316 SST	06-11485-306	06-11485-406	06-11485-506	06-11485-606	06-11485-706	06-11485-806	06-11485-906
		High set	316 SST	06-11486-106	06-11486-206	06-11486-306	06-11486-406	06-11486-506	06-11486-606	06-11486-706
2*	Vacuum pallet assembly	Low set	Aluminum	06-11485-101	06-11485-201	06-11485-001	06-11485-601	06-11485-701	06-11485-801	06-11485-901
		High set	Aluminum	06-11486-101	06-11486-201	06-11486-301	06-11486-401	06-11486-501	06-11486-601	06-11486-701
		Low set	316 SST	06-11485-106	06-11485-206	06-11485-006	06-11485-606	06-11485-706	06-11485-806	06-11485-906
		High set	316 SST	06-11486-106	06-11486-206	06-11486-306	06-11486-406	06-11486-506	06-11486-606	06-11486-706
3*	Seat ring	All	Aluminum	02-10438-001	02-10251-001	02-05464-001	02-05478-001	02-05482-001	02-05487-001	02-05499-001
		All	316 SST	02-10438-006	02-10251-006	02-05464-006	02-05478-006	02-05482-006	02-05487-006	02-05499-006
4	Pallet insert	All	PTFE	02-10361-093	02-09704-093	B12741-093	B12742-093	B12743-093	B12744-093	B13288-093
5	Pressure screen	Low set	HDPE	02-10439-051	02-10323-051	B16209-351	B14390-151	B14390-251	B14390-351	B14390-451
		High set	HDPE	02-10439-151	02-10323-151	B16209-451	B14390-551	B14390-651	B14390-751	B14390-851
6	Vacuum screen	All	HDPE	02-11547-051	02-11547-151	02-11547-251	02-11547-351	02-11547-451	02-11547-551	02-11547-651
7	Cover and spacer gasket	Low set	Fiber	02-11380-071	02-11381-071	02-11382-071	02-11383-071	02-11384-071	02-11385-071	02-11386-071
		High set	Nitrile (NBR)	02-11380-075	02-11381-075	02-11382-075	02-11383-075	02-11384-075	02-11385-075	02-11386-075
8	Hood	Low press. set with low vac set	Aluminum	06-11136-01	06-11136-02	06-11136-08	06-11137-01	06-11137-02	06-11137-03	06-11137-04
			Steel	02-10455-003	02-10310-003	02-10066-103	D6064-203	C6433-203	C6436-203	C6500-203
			304 SST	02-10455-005	02-10310-005	02-10066-105	E2331-205	C7119-205	E2322-205	E2317-205
		High press. set with low vac set	Aluminum	06-11136-01	06-11136-02	06-11136-03	06-11137-01	06-11137-02	06-11137-03	06-11137-04
			Steel	02-10455-003	02-10310-003	02-10066-103	D6064-203	C6433-203	C6436-203	C6500-203
			304 SST	02-10455-005	02-10310-005	02-10066-105	E2331-205	C7119-205	E2322-205	E2317-205
		Low press. set with high vac set	Aluminum	06-11545-01	06-11545-02	06-11545-03	06-11137-05	06-11137-06	06-11137-07	06-11137-04
			Steel	02-11197-003	02-11199-003	02-11045-203	02-11004-003	02-11006-003	02-11007-003	C6500-203
			304 SST	02-11197-005	02-11199-005	02-11045-205	02-11004-005	02-11006-005	02-11007-005	E2317-205
		High press. set with high vac set	Aluminum	06-11545-01	06-11545-02	06-11545-04	06-11137-01	06-11137-02	06-11137-03	06-11137-04
	Steel	02-11197-103	02-11199-103	02-11045-303	D6064-203	C6433-203	C6436-203	C6500-203		
	304 SST	02-11197-105	02-11199-105	02-11045-305	E24331-205	C7119-205	E2322-205	E2317-205		
9*	Pressure guide post (hood attm't)	Low set	316 SST	02-11411-106	02-11411-206	02-11412-106	02-11413-106	02-11413-206	02-11415-106	02-11415-206
		High set	316 SST	02-11411-306	02-11411-406	02-11412-206	02-11413-306	02-11413-406	02-11415-306	02-11415-206
10*	Pressure guide post	Low set	316 SST	-	-	-	02-11414-106	02-11414-206	02-11416-106	02-11416-206
		High set	316 SST	-	-	-	02-11414-306	02-11414-406	02-11416-306	02-11416-206
11*	Vacuum guide post	All	316 SST	02-11015-106	02-11015-206	02-11432-106	B14384-106	B14384-206	B14384-506	02-11433-106
12	Spacer ring	All	Aluminum	-	-	-	B14389-011	B14439-011	B14449-011	B16113-011
		All	Steel	-	-	-	B14389-003	B14439-003	B14449-003	B16113-003
		All	316 SST	-	-	-	B14389-006	B14439-006	B14449-006	B16113-006
13	O-ring	All	Nitrile (NBR)	P014-03-285	P014-03-273	P014-03-286	P014-03-287	P014-03-288	P014-03-289	P014-03-290
14	Retaining ring	All	Polypropylene	02-11396	02-11397	02-11398	02-11399	02-11400	02-11401	02-11402

* For all weather parts, add -1 to end of listed part numbers.

VAREC 2010B/2020B/3500B SERIES PRESSURE AND VACUUM RELIEF VALVE

INSTRUCTION, OPERATION AND MAINTENANCE MANUAL

TABLE 13 - REPLACEMENT PARTS MODEL 2020B (SEE FIGURES 6 AND 7)

Item no.	Description	Usage	Material	Nominal pipe size (inlet x outlet)						
				2" x 3"	3" x 4"	4" x 6"	6" x 8"	8" x 10"	10" x 12"	12" x 14"
1*	Pallet assembly	Low set.	Aluminum	06-11485-101	06-11485-201	06-11485-001	06-11485-601	06-11485-701	06-11485-801	06-11485-901
		High set.	Aluminum	06-11486-101	06-11486-201	06-11486-301	06-11486-401	06-11486-501	06-11486-601	06-11486-701
		Low set.	316 SST	06-11485-106	06-11485-206	06-11485-006	06-11485-606	06-11485-706	06-11485-806	06-11485-906
2*	Seat ring	High set.	316 SST	06-11486-106	06-11486-206	06-11486-306	06-11486-406	06-11486-506	06-11486-606	06-11486-706
		All	Aluminum	02-10438-001	02-10251-001	02-05464-001	02-05478-001	02-05482-001	02-05487-001	02-05499-001
3	Pallet insert	All	316 SST	02-10438-006	02-10251-006	02-05464-006	02-05478-006	02-05482-006	02-05487-006	02-05499-006
		All	PTFE	02-10361-093	02-09704-093	B12741-093	B12742-093	B12743-093	B12744-093	B13288-093
4	Screen	All	HDPE	02-11547-051	02-11547-151	02-11547-251	02-11547-351	02-11547-451	02-11547-551	02-11547-651
5	Cover and spacer gasket	Low set.	Fiber	02-11380-071	02-11381-071	02-11382-071	02-11383-071	02-11384-071	02-11385-071	02-11386-071
		High set.	Nitrile (NBR)	02-11380-075	02-11381-075	02-11382-075	02-11383-075	02-11384-075	02-11385-075	02-11386-075
6*	Press. guide post	All	316 SST	02-11015-106	02-11015-306	02-11432-106	B16553-406	B16553-206	B16553-506	02-11433-106
7*	Vacuum guide post	All	316 SST	02-11015-106	02-11015-206	02-11432-106	B14384-106	B14384-206	B14384-506	02-11433-106
8	O-ring	All	Nitrile (NBR)	P014-03-285	P014-03-273	P014-03-286	P014-03-287	P014-03-288	P014-03-289	P014-03-290
9	Retaining ring	All	Polypropylene	02-11396	02-11397	02-11398	02-11399	02-11400	02-11401	02-11402

* For all weather parts, add -1 to end of listed part numbers.

TABLE 14 - REPLACEMENT PARTS MODEL 3500B (SEE FIGURES 8 AND 9)

Item no.	Description	Usage	Material	Nominal pipe size (inlet x outlet)						
				2" x 3"	3" x 4"	4" x 6"	6" x 8"	8" x 10"	10" x 12"	12" x 14"
1*	Pallet assembly	Low set.	Aluminum	06-11485-101	06-11485-201	06-11485-001	06-11485-601	06-11485-701	06-11485-801	06-11485-901
		High set.	Aluminum	06-11486-101	06-11486-201	06-11486-301	06-11486-401	06-11486-501	06-11486-601	06-11486-701
		Low set.	316 SST	06-11485-106	06-11485-206	06-11485-006	06-11485-606	06-11485-706	06-11485-806	06-11485-906
		High set.	316 SST	06-11486-106	06-11486-206	06-11486-306	06-11486-406	06-11486-506	06-11486-606	06-11486-706
2*	Seat ring	All	Aluminum	02-10438-001	02-10251-001	02-05464-001	02-05478-001	02-05482-001	02-05487-001	02-05499-001
		All	316 SST	02-10438-006	02-10251-006	02-05464-006	02-05478-006	02-05482-006	02-05487-006	02-05499-006
3	Pallet insert	All	PTFE	02-10361-093	02-09704-093	B12741-093	B12742-093	B12743-093	B12744-093	B13288-093
4	Screen	All	HDPE	02-11547-051	02-11547-151	02-11547-251	02-11547-351	02-11547-451	02-11547-551	02-11547-651
5	Cover and spacer gasket	All	Nitrile (NBR)	02-11380-075	02-11381-075	02-11382-075	02-11383-075	02-11384-075	02-11385-075	02-11386-075
6*	Pressure guide post	All	316 SST	02-11015-106	02-11015-206	02-11432-106	B14384-106	B14384-206	B14384-506	02-11433-106
7	O-ring	All	Nitrile (NBR)	P014-03-285	P014-03-273	P014-03-286	P014-03-287	P014-03-288	P014-03-289	P014-03-290
8	Retaining ring	All	Polypropylene	02-11396	02-11397	02-11398	02-11399	02-11400	02-11401	02-11402

* For all weather parts, add -1 to end of listed part numbers.

Neither Emerson, Emerson Automation Solutions, nor any of their affiliated entities assumes responsibility for the selection, use or maintenance of any product. Responsibility for proper selection, use, and maintenance of any product remains solely with the purchaser and end user.

Varec is a mark owned by one of the companies in the Emerson Automation Solutions business unit of Emerson Electric Co. Emerson Automation Solutions, Emerson and the Emerson logo are trademarks and service marks of Emerson Electric Co. All other marks are the property of their respective owners.

The contents of this publication are presented for informational purposes only, and while every effort has been made to ensure their accuracy, they are not to be construed as warranties or guarantees, express or implied, regarding the products or services described herein or their use or applicability. All sales are governed by our terms and conditions, which are available upon request. We reserve the right to modify or improve the designs or specifications of such products at any time without notice.