

Rebel EMP 205ic AC/DC



Spare parts list

Ordering number	Product	Notes
0558 102 553	Rebel EMP205ic AC/DC	CD341YY-XXXXXX

Spare parts may be ordered through your nearest ESAB dealer, see esab.com. When ordering, please state product type, serial number, denominations and ordering numbers according to the spare parts list. This facilitates dispatch and ensures correct delivery.

Maintenance and repair work should be performed by an experienced person, and electrical work only by a trained electrician. Use only recommended spare parts.

TABLE OF CONTENTS

SPARE PARTS **4**
 Housing assembly **4**
 Connection parts **6**
 User-interface assembly **8**
 Control/power module parts **9**
WEAR PARTS **11**

SPARE PARTS

Housing assembly

C=component designation in the circuit diagram					
Item	Qty	Ordering no.	Denomination	Notes	C
1	1	0558 102 397	Side Frame, Power Side		
2	2	0558 102 664	Barrel nut	M6×35	
3	1	0558 102 398	Side Frame, Spool Side		
4	2	0558 102 664	Barrel bolt	M6×175	
5	8		Socket head screw	M6×1×18	
6	4	0558 102 399	Handle		
7	1	0558 102 400	Top handle		
8	2		Flat washer	M6	
9	2		Washer split lock	M6	
10	2		Socket head screw	M6×1×45	
11	1	0558 102 401	Side door, power side		
12	6		Socket head low profile screw	M4×10	
13	1	0558 102 402	Front foot		
14	1	0558 102 403	Rear foot		
15	4		Socket head screw	M6×1×18	
16	1	0558 102 404	Side door, spool side		
17	1	0558 102 406	Hinge		
18	4		Washer	M4×8	
19	4		Cap screw	M4×8	
20	2	0558 102 407	Hinge pin		
21	2		Lock nut	M5	
22	1	0558 102 405	Roller latchassembly		
23	2		Screw	M4×16	
24	2		Flat washer	M4×9	
25	2		Lock nut	M4×0.7	

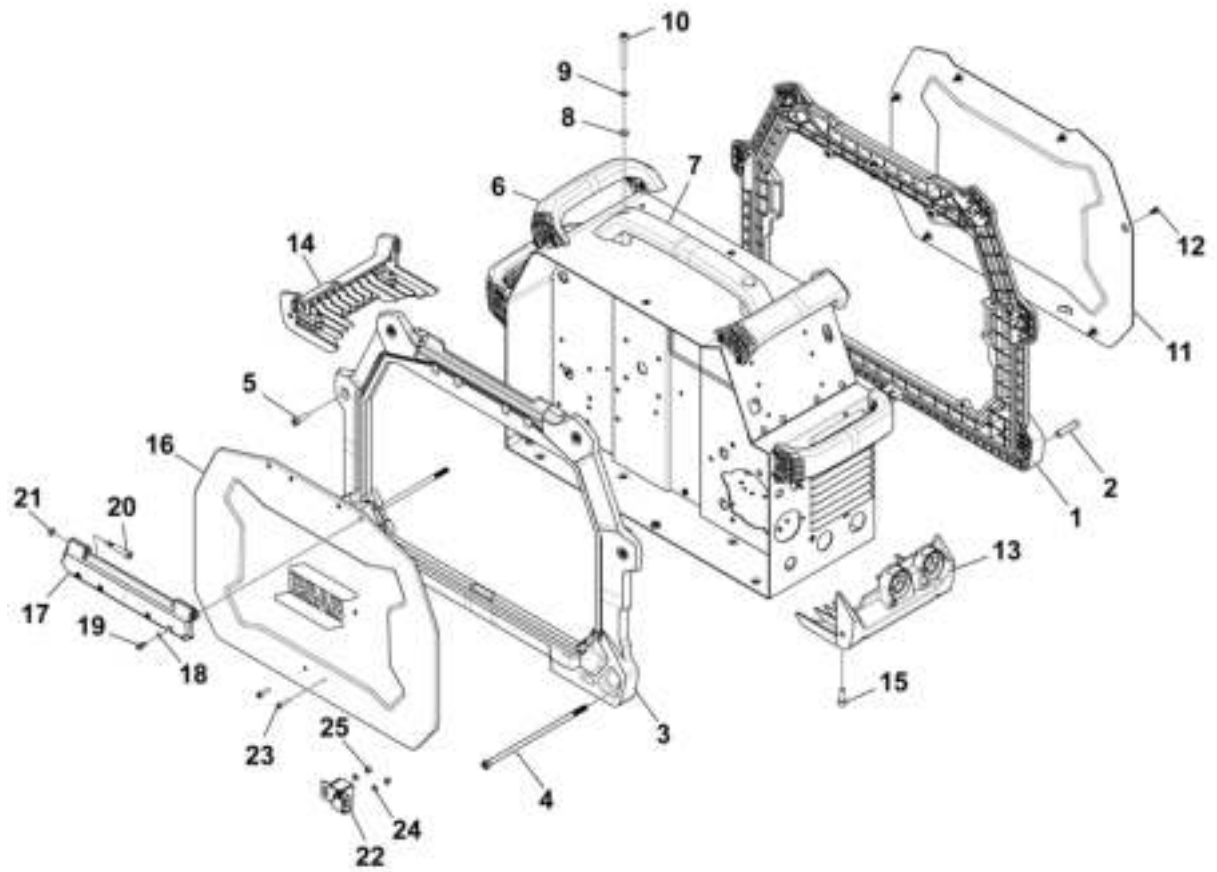

Connection parts

C=component designation in the circuit diagram					
Item	Qty	Ordering no.	Denomination	Notes	C
1	1	0558 102 408	Wire feeder mechanism		
2	1	0558 102 647	8-pin Remote Cable Assembly		
3	1	0558 102 411	Brake hub kit		
4	1	0558 102 648	MIG Solenoid Gas Assembly		GV1
5		0558 102 649	TIG Solenoid Gas Assembly		GV2
6	1	0558 102 925	Dual Solenoid Bracket		
7	1	0558 102 650	LED Wire Harness Assembly		
8	3	0558 102 414	Gas connector, CSA		
9	1	0558 102 415	Main supply switch		
10	1	0558 102 521	Circuit breaker		
11	1	0558 102 646	Fan Bracket Assembly		FM1&2
12	1	0558 102 651	Protective Mylar Sheet		
13	1	0558 102 410	Brake hub nut		
14	2	0558 102 418	OKC Contact, Female		
15	1	0558 102 419	Polarity Change Cable Assembly		
16	1	0464 751 087	110/230V connector assembly		
17	2	0464 751 088	Fuse		

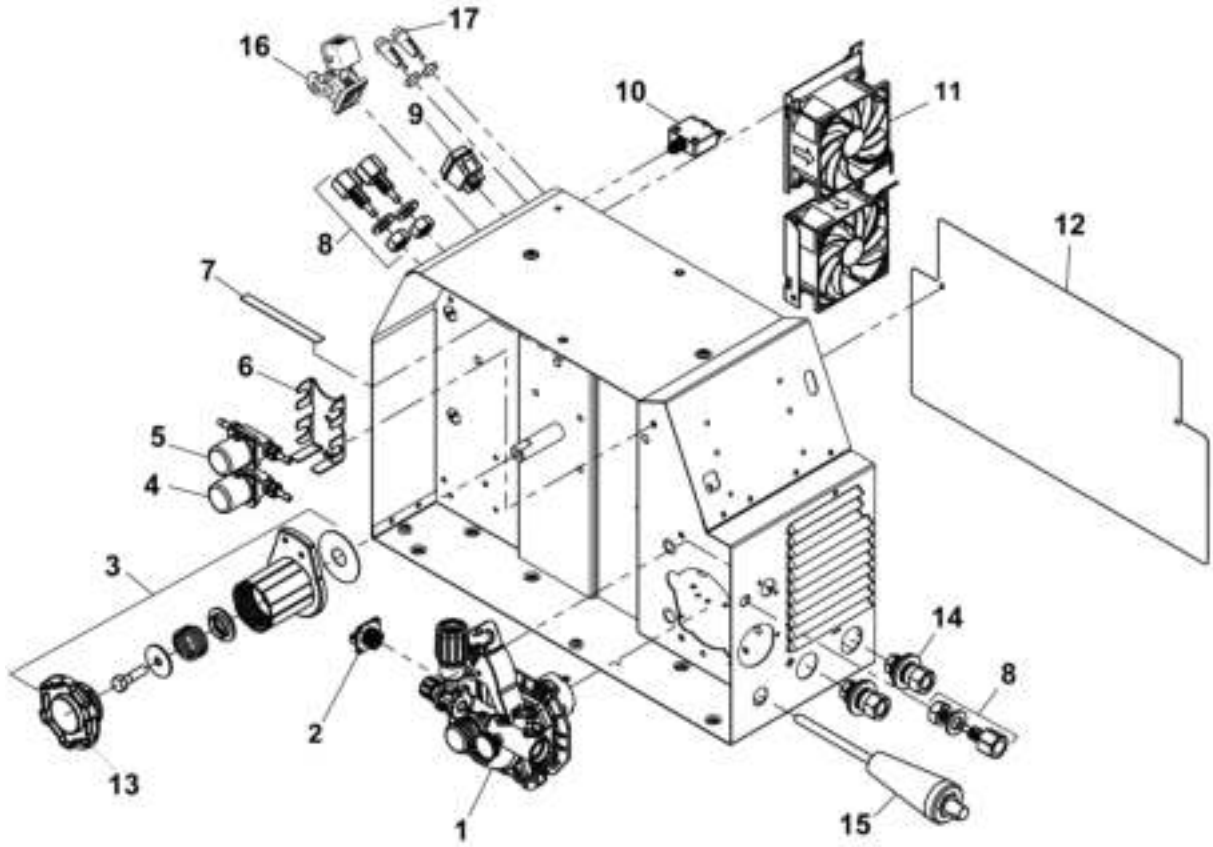

User-interface assembly

C=circuit designation in the circuit diagram					
Item	Qty	Ordering no.	Denomination	Notes	C
1	1	0464 663 074	EMP 205ic panel assembly		
2	2		Encoder for small knob		
3	1		Encoder for large knob		
4	1	0558 102 438	Replaceable display lens		
5	2	0558 102 440	Knob, small		
6	1	0558 102 441	Knob, large		
7	1	0558 102 653	EMP 205ic lens assembly kit		

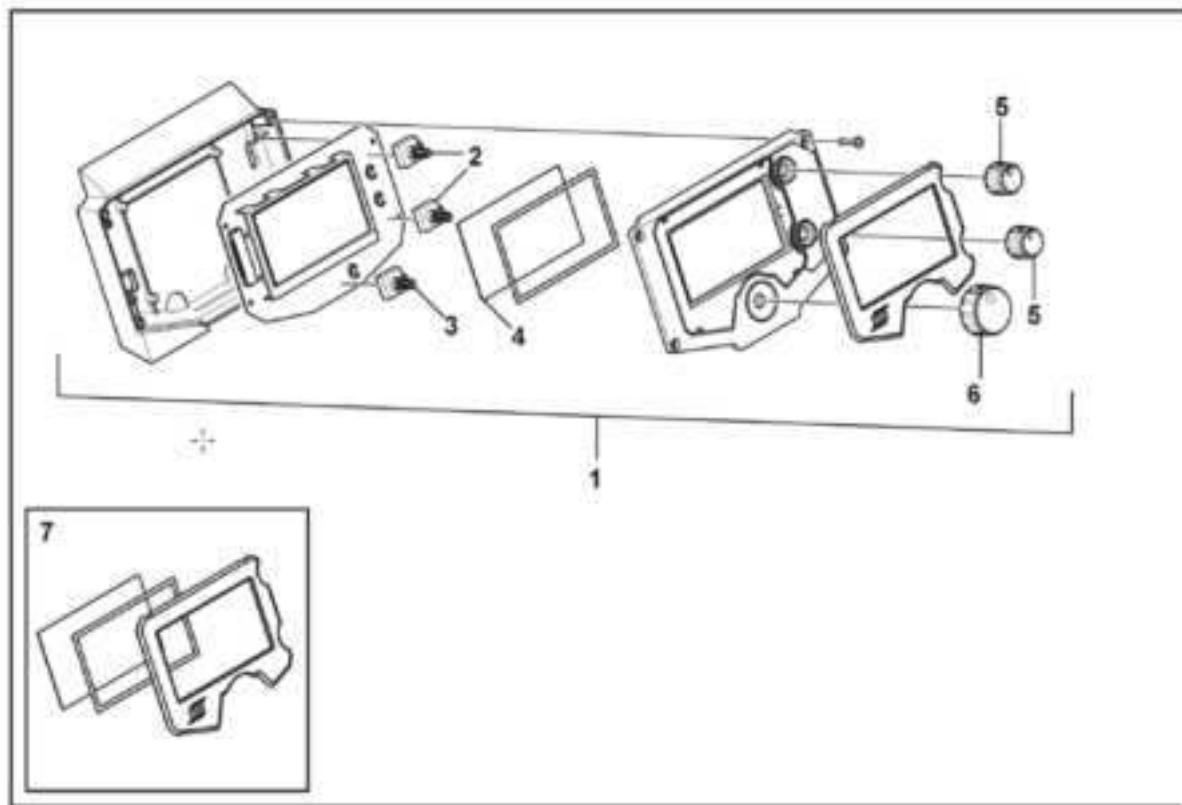

Control/power module parts

C=component designation in the circuit diagram					
Item	Qty	Ordering no.	Denomination	Notes	C
1	1	0558 102 655	AC/DC Module		15AP3
2	1	0558 102 654	Main Power PCBA		15AP1
3	1	0558 102 607	Control PCBA	PCB must be pre-configured before usage	20AP1
4	1	0558 102 659	Output Inductor Assembly		L2
5	1	0558 102 661	Main Transformer Assembly		T1
6	1	0464 637 011	HF Inductor Assembly		T2
7	1	0558 102 657	HF PCBA		15AP4
8	1	0464 637 012	HF Bypass PCBA		15AP5
9	1	0558 102 658	IPS PCBA		15AP2
10	1	0558 102 662	Strain relief assembly		
11	1	0464 637 014	Mains Cable with Input Power Plug		
12	1	0558 102 417	Current sensor		
13	1	0465 689 003	Fan management PCB		20AP2
14	1	0558 103 451	Wire Harness 1, Power PCB to Control PCB	CN4-CN19	
15	1	0558 103 452	Wire Harness 2, Power PCB to Control PCB	CN1-CN17	
16	1	0558 103 453	Wire Harness 1, IPS PCB to Control PCB	CN2-CN2	
17	1	0558 103 454	Wire Harness 2, IPS PCB to Control PCB	CN1-CN8	
18	1	0558 103 456	Wire Harness, Control PCB to HMI	CN6-CN3	
19	1	0558 103 460	Wire Harness, ACDC Inverter to HF Starter	CN2-CN1	

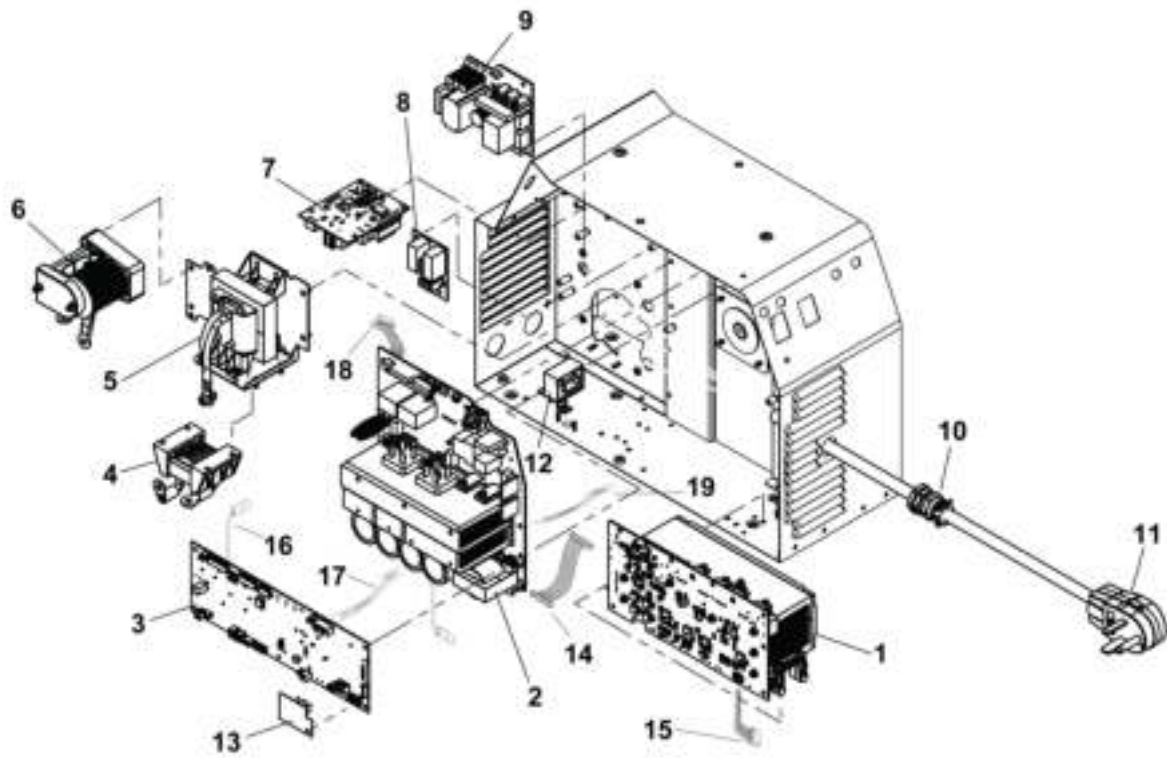

WEAR PARTS

Item	Qty	Ordering No.	Denomination	Wire type	Wire dimensions
1	1	0558 102 326	Wire outlet guide	Fe/SS/ Flux Cored	0.030 in. / 0.035 in. / 0.045 in. (0.7 mm / 0.8 mm / 1.1 mm)
	1	0558 102 327	Wire outlet guide	Fe/SS/ Flux Cored	0.024 in. (0.6 mm)
	1	0464 598 880	Wire outlet guide	Aluminium	
2	1	0558 102 328	Wire inlet guide	Fe/SS/ Flux Cored	0.024 in. / 0.030 in. / 0.035 in. / 0.045 in. (0.6 mm / 0.7 mm / 0.8 mm / 1.1 mm)
3	1	0558 102 334	Key-drive shaft	N/A	N/A
4	1	7977036	Feed roll "V" groove	Fe/SS	0.024 in. / 0.030 in. (0.6 mm / 0.7 mm)
	1	W4014800	Feed roll "V" groove	Fe/SS	0.024 in. / 0.035 in. (0.6 mm / 0.8 mm)
	1	7977732	Feed roll "V" knurled	Flux Cored	0.030 in. / 0.035 in. (0.7 mm / 0.8 mm)
	1	7044277	Feed roll "V" knurled	Flux Cored	0.045 in. (1.1 mm)
	1	0367 556 004	Feed roll "U" groove	N/A	0.039 in. / 0.047 in. (1.0 mm / 1.2 mm)
5	1	0558 102 518	Feed roller retaining knob	N/A	N/A
6	1	0558 102 331	Pressure arm complete assembly	N/A	N/A
7	1	0558 102 330	Screw	N/A	N/A
8	1	0558 102 332	MIG torch locking knob	N/A	N/A
9	1	0558 102 329	Locking knob (Wire tension)	N/A	N/A

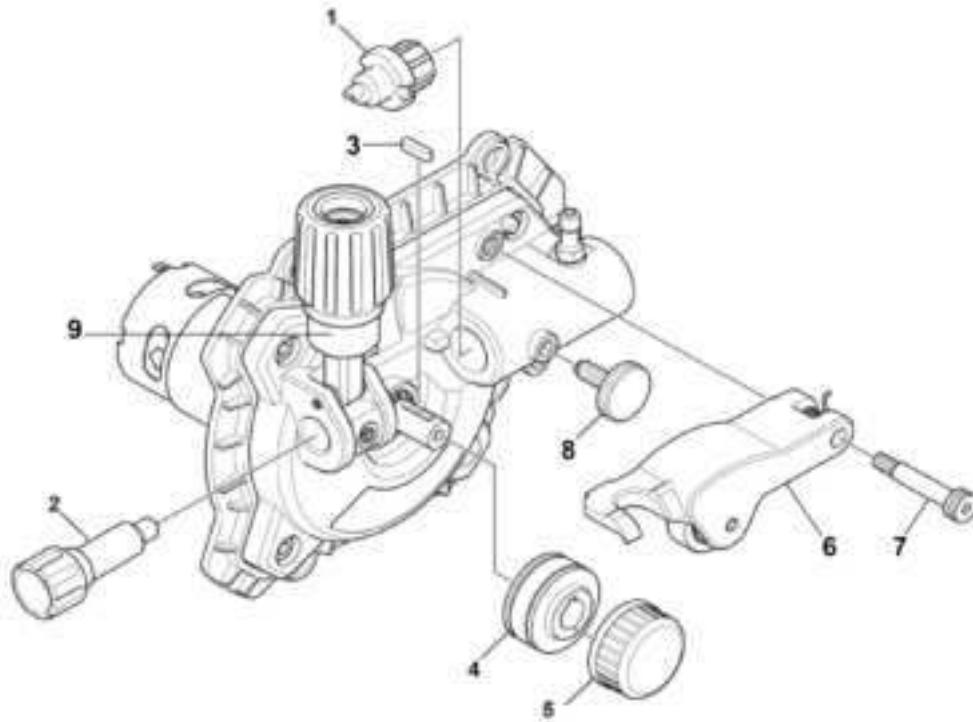



A WORLD OF PRODUCTS AND SOLUTIONS.



For contact information visit esab.com

ESAB Corporation, 2800 Airport Road Denton, TX 76207, USA, Phone +1 800 378 8123

manuals.esab.com

