

70.3 Electrical

Accessories integrating a MagSafe Charger Module shall comply with the electrical requirements in this section.

70.3.1 Power

Accessories integrating a MagSafe Charger Module shall provide power from either:

- An internal power supply.
- An external USB power source.

If the accessory integrates an [Internal Power Supply](#) (page 629), it:

- May accept external power using any of the following integrated connectors so long as the accessory actively conditions and regulates the power:
 - [USB-C Receptacle](#) (page 831).
 - [USB-C Plug](#) (page 829).
 - Non-USB connector.
- May consume some of the external power for its own purposes so long as all MagSafe Charger Module power requirements are met.

If the accessory relies on an [External USB Power Source](#) (page 629) to provide power to the MagSafe Charger Module and does not contain its own internal power supply, it:

- Shall connect to the external USB power source using a [USB-C Plug](#) (page 829).
- Shall not consume any power from the external USB power source.
- Shall not monitor or modify the USB D+/D- or CC signals from the external USB power source.

The accessory shall integrate reverse voltage protection (RVP) between the MagSafe Charger Module power and ground.

The MagSafe Charger Module maximum average current is 2.5 A at 9 V. The current is further limited based on the power source identification (for example, USB PD, USB D+/D- resistor network values, or USB enumeration).

The MagSafe Charger Module includes:

- Overvoltage protection (OVP).
- Overcurrent protection (OCP).
- Overtemperature protection (OTP).
- Foreign object detection (FOD).

70.3.1.1 Internal Power Supply

A MagSafe Charger Module powered by an accessory's internal power supply shall be configured to operate in 9 V mode using the [PowerMode](#) (page 635) command. After configuration, the USB D+/D- and CC pads shall be left Not Connected (NC) as specified in [Pads and Assignments](#) (page 630).

The accessory's internal power supply for the MagSafe Charger Module shall:

- Support a load of 0 W to 20 W (2.22 A at 9 V). Apple recommends supporting up to 22.5 W (2.5 A at 9 V).
- Regulate input voltage at the PWR pad of the MagSafe Charger Module to 9.0 V \pm 5% under any supported load.
- Hold PWR ripple below:
 - 180 mVpp from 1 kHz to 4 kHz under any supported load.
 - 400 mVpp below 1 kHz or above 4 kHz under any supported load.
- Have a PWR rise time (10% to 90%) of less than 10 ms during power on.
- Tolerate a transient current up to 4.5 A for up to 1 ms.

70.3.1.2 External USB Power Source

A MagSafe Charger Module powered by an external USB power source shall be configured to operate in USB mode using the [PowerMode](#) (page 635) command.

Accessories relying on an external USB power source to provide power to the MagSafe Charger Module shall:

- Have maximum 112 m Ω round trip DCR (USB VBUS to Ground) between the MagSafe Charger Module connector and the accessory's [USB-C Plug](#) (page 829).
- Have a VBUS DCR less than 92 m Ω assuming 1 m cable.
- Have a GND DCR less than 20 m Ω assuming 1 m cable.
- Have a D+/D- DCR less than 1013 m Ω assuming 1 m cable.
- Have a CC DCR less than 5580 m Ω assuming 1 m cable.
- Pass the USB-IF Full Speed signal quality test. See [Full Speed USB](#) (page 826) and [Full Speed USB](#) (page 837).
- Meet the USB-IF inrush current specification of 51.5 μ C.

See the USB-IF *Full and Low Speed Electrical and Interoperability Compliance Test Procedure* and *Gold Suite Test Procedure* for USB-IF test procedures.

If the accessory implements additional OCP, the maximum round trip DCR shall include the on-resistance of the OCP circuit.

If the accessory bundles an external USB power source, it shall provide at least 20 W (2.22 A at 9 V). Apple recommends supporting up to 22.5 W (2.5 A at 9 V).

70.3.1.3 Charging Efficiency

Accessories integrating a MagSafe Charger Module shall not impair device's ability to efficiently charge from provided power.

70.3.2 Pads and Assignments

The module pad assignments are shown in dimensional drawings.

Table 70-1 MagSafe Charger Module Pads

Pad	Name	USB Mode Assignment	9 V Mode Assignment
1	PWR	USB VBUS	9 V
2	USB D-	USB D-	NC
3	USB D+	USB D+	NC
4	USB CC	USB CC	NC
5	GND	Ground	Ground

The module housing is grounded internally and shall not be directly connected to an external ground. Care should be taken to ensure any connection to the GND pad does not short to the enclosure.

Signals from the USB D+ and D- pads shall be routed as a differential pair.

All pads support up to 20 AWG wires.

70.3.3 ESD

Accessories shall ensure there is no arcing path to the MagSafe Charger Module housing.

Air gaps between the accessory housing and the module should be covered using a non-conductive coating or other material to prevent arcing.

If air gaps cannot be covered, the module's metal housing near the gap should be insulated with a coating, such as:

- >250 μm polyurethane.
- >100 μm parylene.

70.3.4 EMC

Accessories integrating the MagSafe Charger Module should be designed for [Electromagnetic Compatibility \(EMC\)](#) (page 328).

The wires connected to the module pads should be part of a shielded cable. The shield and drain/ground wires should be tied together and connected to the GND pad of the module. The shield shall not be connected to the module housing.

Avoid coupling from the accessory enclosure to the module housing.

Cable bundles should be physically isolated from the module housing to minimize unwanted coupling. A spacer or absorber material may be placed between the cable bundle and the module housing for additional isolation. The material should be 1 mm thick and should be one of the following:

- RF absorber material effective at 30-100 MHz.
- Spacer with relative permittivity $\epsilon_r = 1$ (for example, foam).

RF absorber material may be wrapped around the cable core to further attenuate EMI noise and reduce emissions. Wrap the absorber material around the shield before applying the jacket. The absorber should be $>35 \mu\text{m}$ thick and should have:

- $\mu' > 90, \mu'' > 35$ @ 30 MHz.
- $\mu' > 60, \mu'' > 40$ @ 100 MHz.

A common mode choke effective at 30-100 MHz should be included in the accessory's internal power supply or in any bundled power adapters. The common mode choke should have:

- $Z > 200 \Omega$ @ 30 MHz.
- $Z > 500 \Omega$ @ 100 MHz.

If the accessory includes a bundled power adapter, a ferrite core with high impedance in 30-100 MHz frequency range may be added to the power cord to reduce emissions. The ferrite core should have:

- $Z > 130 \Omega$ @ 25 MHz.
- $Z > 260 \Omega$ @ 100 MHz.

To reduce common mode noise potential, the accessory may include grounded metal outside of the module area to increase capacitance between the accessory and the device.

70.3.5 SAR

Accessories integrating a MagSafe Charger Module in "portable" conditions may exceed 0 mm H-field measurement limits. Collaborating with Ansys, Apple developed a software tool to perform [Specific Absorption Rate \(SAR\)](#) (page 65) simulations. See the *Simulation Tool for RF Exposure Assessment* document in the MFi Portal for more information.

70.3.6 Inductive Coil

The MagSafe Charger Module inductive coil has 10.6 turns with an outer diameter of ≈ 39.3 mm.

70.4 Charging Status

To monitor charging status, accessories may use the HID report with ID 0xA1 on interface 2, consisting of HID Vendor Page (0xFF00) Usage ID 0x0011, a uint8 value representing the following charging states:

- 0 - Empty.
- 1 - Charging up to 5 W.
- 2 - Charging up to 7.5 W.
- 3 - Charging up to 15 W.

The charging status report is sent once per second and can be used to determine if the module is powered.

Accessories may indicate to the user when the module is powered and its charging state, using an LED or other means. For example, a multi-color LED may use green to indicate the charger is powered and other color(s) to indicate the charging state when a device is present.

70.5 Controlling Power in 9 V Mode

Available power to the MagSafe Charger Module may be adjusted dynamically when using an [Internal Power Supply](#) (page 629) in 9 V [PowerMode](#) (page 635).

To configure the available power, the host may send a HID report with ID 0xA0 on interface 1, consisting of HID Vendor Page (0xFF00) Usage ID 0x0046, a uint8 value for the available power in W.

Charging may be disabled at any time by setting the available power to '0'. The minimum value required to enable inductive charging is 12 W. When the [Charging Status](#) (page 632) is:

- '0' or '3', the value may be dynamically adjusted.
- '1' or '2', values are not dynamically adjustable. Charging has to be stopped before setting a new available power value.

70.6 Firmware Update Over USB

MagSafe Charger Module supports firmware updates over USB-C from Mac computers. To register an accessory for this support, email a request to mfi-uarp-adopters@group.apple.com with the following:

- Email subject containing the:
 - Module name (for example, "C222" or "C223").
 - Accessory's USB VID/PID in hex (for example, "XXXX/XXXX").
- Email body containing:

- Requesting company's name.
- MFi Product Plan UID (PPUID) from the MFi portal (for example, "XXXXXXXXXXXXXXXXXX").
- MFi Product Plan ID (PPID) from the MFi portal (for example, "XXXXXX-XXXXXX").
- Enable after date (optional).

70.7 Factory Configuration

The MagSafe Charger Module exposes a [USB Virtual COM Port](#) (page 637) (VCP) to use for factory configuration. Connect the pads to a cable terminating in a USB-C plug to access the interface.

The MagSafe Charger Module factory configuration interface provides commands to set and read configuration parameters. Commands are terminated by a newline character and take two forms:

- "VendorSet *ParameterName* *Value*" to set the value of a parameter.
- "VendorGet *ParameterName*" to read the current value of a parameter.

Command responses for both VendorSet and VendorGet take the form:

"<*ParameterName*-*CurrentValue*>". This response may be used to confirm the value has been set correctly.

Hexadecimal values shall be prefixed with 0x.

The VendorSet command takes exactly two arguments separated by spaces. If the value to set is a string containing spaces (for example, "Charging Cable Model Name"), each space shall be represented by an underscore character (for example, "VendorSet *ProductName* *Charging_Cable_Model_Name*").

70.7.1 Parameters

The following parameters shall be configured at the time of accessory manufacturing:

- [VendorID](#) (page 634)
- [ProductID](#) (page 634)
- [ProductPlanUID](#) (page 634)
- [VendorName](#) (page 634)
- [ProductName](#) (page 634)
- [ModelNumber](#) (page 634)
- [HardwareVersion](#) (page 634)
- [SerialNumber](#) (page 635)
- [PowerMode](#) (page 635)
- [LockConfig](#) (page 635)

Every MagSafe Charger Module:

- Shall set the Vendor ID (VID) as assigned by the USB-IF and a unique Product ID (PID) assigned by the accessory developer. The VID shall correspond to the brand name appearing on the accessory or its packaging. See [USB Host Mode](#) (page 491).
- Shall set the Vendor Name, Product Name, and Model Number to human-readable strings matching names appearing on the accessory or its packaging.
- Shall not be configured with empty strings or generic string values.
- Shall be configured with a unique serialized Serial Number.

The [TempConfig](#) (page 635) parameter may be used to verify the configuration before permanently locking the MagSafe Charger Module.

70.7.1.1 VendorID

A string representation of the hex value of the vendor ID (VID) from the manufacturer, including the 0x prefix.

70.7.1.2 ProductID

A string representation of the hex value of the product ID (PID) from the manufacturer, including the 0x prefix.

70.7.1.3 ProductPlanUID

A string representation of the Product Plan's UID (PPUID) from the MFi portal (up to 36 UTF8 characters). Note: the Product Plan UID is different from the Product Plan ID.

70.7.1.4 VendorName

A string representation of the vendor name from the manufacturer (up to 64 UTF8 characters).

70.7.1.5 ProductName

A string representation of the product name from the manufacturer (up to 64 UTF8 characters).

70.7.1.6 ModelNumber

A string representation of the model number from the manufacturer (up to 32 UTF8 characters).

70.7.1.7 HardwareVersion

A string representation of the hardware version from the manufacturer (1 byte), provided as a decimal or hex value.

70.7.1.8 SerialNumber

A string representation of the serial number from the manufacturer (up to 32 UTF8 characters).

70.7.1.9 PowerMode

A number indicating the power mode:

- 1 = USB / USB-PD mode.
- 2 = 9 V mode. Input voltage and operating current range is fixed.
- All other values are reserved.

70.7.1.10 TempConfig

A number indicating the configuration mode:

- 0 = Default.
- 1 = Temporarily use the configured parameters to enumerate over USB on the next boot, then return to VCP mode on the following boot. This setting may be used to verify the parameters have been set correctly. This setting does not enable inductive charging.
- All other values are reserved.

70.7.1.11 LockConfig

A number indicating the configuration lock mode:

- 0 = Unlocked.
- 1 = Permanently lock configuration on the next boot. This setting shall be used for all production units.
- All other values are reserved.

70.7.2 Examples

70.7.2.1 Configure, Verify, and Lock

The following is an example factory configuration sequence which permanently locks the MagSafe Charger Module immediately after configuration:

1. Apply power to the MagSafe Charger Module and connect to the USB VCP interface.
2. Issues all `VendorSet ParameterName Value` commands to configure the module:
 - `VendorSet VendorID 0x1234`
 - `VendorSet ProductID 0x5678`
 - `VendorSet ProductPlanUID ABCDEFGH12345678`
 - `VendorSet VendorName Example_Product_Developer`
 - `VendorSet ProductName Example_Product`
 - `VendorSet ModelNumber ABC_123`

- VendorSet HardwareVersion 0x01
 - VendorSet SerialNumber ABCDEF123456
 - VendorSet PowerMode 1
3. Verify all command responses match the expected values:
 - <VendorID-0x1234>
 - <ProductID-0x5678>
 - <ProductPlanUID-ABCDEFGH12345678>
 - <VendorName-Example Product Developer>
 - <ProductName-Example Product>
 - <ModelNumber-ABC 123>
 - <HardwareVersion-1>
 - <SerialNumber-ABCDEF123456>
 - <PowerMode-1>
 4. Issue VendorSet LockConfig 1 (permanently lock firmware configuration).
 5. Disconnect power.

70.7.2.2 Configure and Test

The following is an example manual configuration sequence to tests the configuration, but does not permanently lock the MagSafe Charger Module:

1. Apply power to the MagSafe Charger Module and connect to the USB VCP interface.
2. Issue all VendorSet *ParameterName Value* commands to configure the module:
 - VendorSet VendorID 0x1234
 - VendorSet ProductID 0x5678
 - VendorSet ProductPlanUID ABCDEF12345678
 - VendorSet VendorName Example_Product_Developer
 - VendorSet ProductName Example_Product
 - VendorSet ModelNumber ABC_123
 - VendorSet HardwareVersion 0x01
 - VendorSet SerialNumber ABCDEF123456
 - VendorSet PowerMode 1
3. Issue VendorSet TempConfig 1 (next boot will use configured parameter values for testing).
4. Cycle power.
5. The MagSafe Charger Module boots, enumerating using the configured parameters.
6. Verify the MagSafe Charger Module has been correctly configured using the following procedure on a Mac (or its equivalent for another computer/operating system combination):
 - a. Open *System Information* on the Mac.
 - b. Select *USB* under the *Hardware* category on the left pane.
 - c. Verify the "Example Product" is listed in the USB device tree.

- d. Select the "Example Product" and verify all displayed values, for example: Product Name, Product ID, Vendor ID, Serial Number, Manufacturer (Vendor Name).
7. Cycle power and connect to the USB VCP interface to continue configuration.

70.7.3 USB Virtual COM Port

The USB Virtual COM Port (VCP) enables configuration of the MagSafe Charger Module.

70.7.3.1 Mac

When using a Mac, the MagSafe Charger Module is recognized as a USB serial device. The accessory will appear as `/dev/tty.usbmodem-<identifier>`. The interface may be accessed using various serial interface programs (for example, executing `screen /dev/tty.usbmodem-<identifier>` given the appropriate identifier in a terminal).

70.7.3.2 Windows XP/7/8

When using a computer running Windows XP/7/8, first install the STM32 Virtual COM Port Driver (part number STSW-STM32102) from <https://www.st.com/en/development-tools/stsw-stm32102.html>. Once installed, edit the `stmcdc.inf` file to add Apple VID `0x05AC` and the MagSafe Charger Module (C222) PID `0x0501` & MagSafe Charger Module (C223) PID `0x139B` to the DeviceList sections as follows:

```
[DeviceList.NT]
%DESCRIPTION%=DriverInstall,USB\VID_0483&PID_5740
%DESCRIPTION%=DriverInstall,USB\VID_05AC&PID_0501
%DESCRIPTION%=DriverInstall,USB\VID_05AC&PID_139B
[DeviceList.NTamd64]
%DESCRIPTION%=DriverInstall,USB\VID_0483&PID_5740
%DESCRIPTION%=DriverInstall,USB\VID_05AC&PID_0501
%DESCRIPTION%=DriverInstall,USB\VID_05AC&PID_139B
```

If the VCP is not identified properly upon connection, update the driver using the Windows Device Manager. If the accessory is listed as a Composite device, select it and update the driver (choose "Have Disk", and browse to the folder containing the updated `stmcdc.inf` file).

70.9 Magsafe Charger Module (C222) Dimensions 2 of 2

ENCLOSURE INTEGRATION

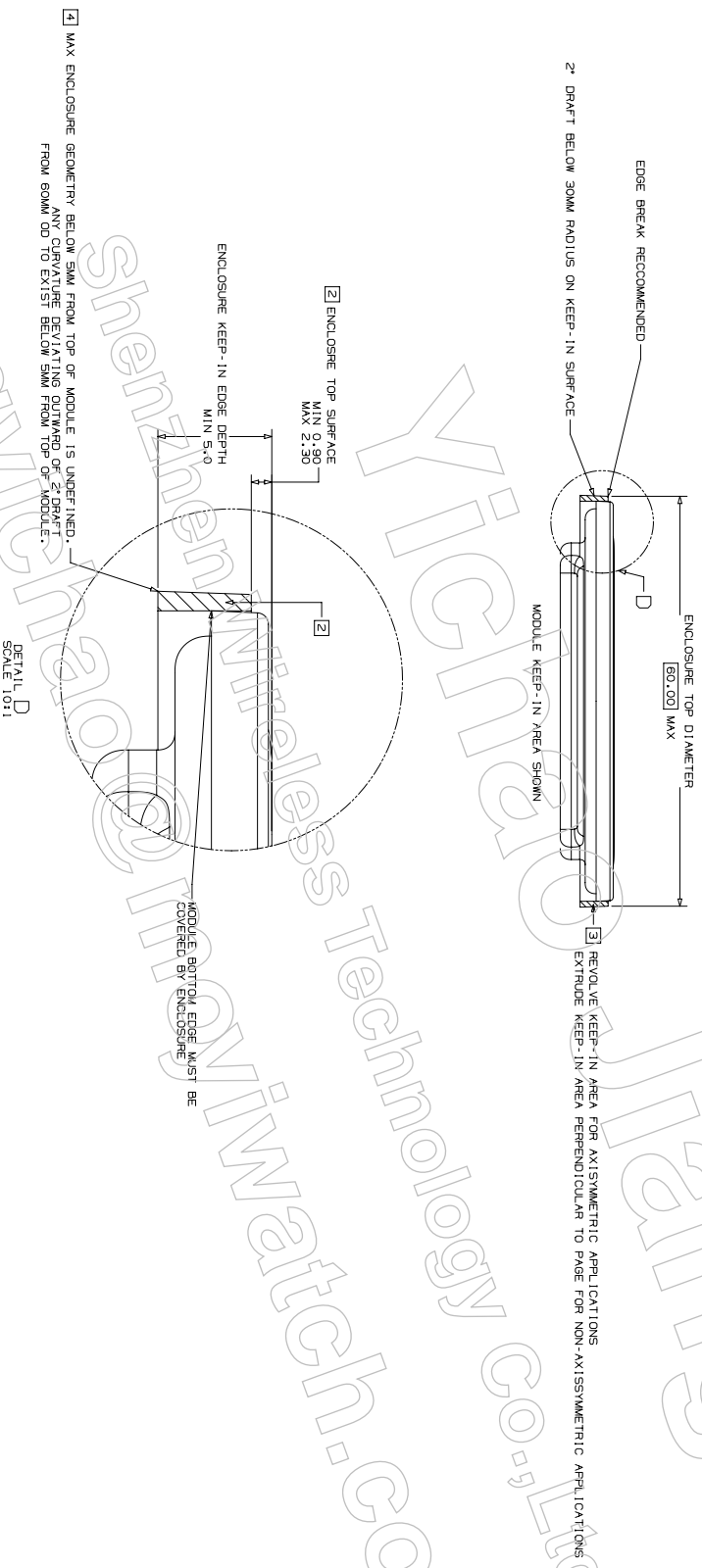

<small> NOTICE OF CONFIDENTIALITY: THE INFORMATION CONTAINED HEREIN IS THE PROPERTY OF APPLE INC. AND IS INTENDED FOR THE EXCLUSIVE USE OF THE INDIVIDUAL OR ENTITY TO WHOM IT IS ADDRESSED. IT IS NOT TO BE DISSEMINATED OR USED FOR ANY OTHER PURPOSE WITHOUT THE EXPRESS WRITTEN PERMISSION OF APPLE INC. © 2022 APPLE INC. ALL RIGHTS RESERVED. </small>	
	Apple Inc. 1000 Apple Park Blvd Cupertino, CA 95014 408 996 1000
Part Name: D Revision: NONE	Date: 2 of 2

70.13 Test Procedures

Test procedures for accessories integrating the MagSafe Charger Module are contained in this section.

70.13.1 Product Design

1. Verify the accessory:
 - a. Does not scratch or damage the device when attached.
 - b. Does not exceed the 30 mm keep-in from the center of the MagSafe Charger Module surface towards the top edge of the device for all supported device orientations.
 - c. Does not exceed the 5 mm clearance past the 30 mm keep-in.
 - d. Does have at least 5 mm of clearance to the device surface (mating surface) past the 30 mm keep-in.
2. Verify the MagSafe Charger Module surface is proud of the surface of the accessory using calipers depth probe.
3. Verify the bottom edge of the MagSafe Charger Module cap is not visible.

70.13.1.1 Orientation Magnet

If the accessory includes a MagSafe orientation magnet:

1. Use a straight edge to verify the device contact surfaces of the MagSafe Charger Module and orientation magnet are coplanar (aligned in the same plane).
2. Attach a MagSafe-capable device to the accessory and align it with the orientation magnet. Verify there are no gaps between the:
 - MagSafe Charger Module and device.
 - MagSafe orientation magnet and device.

70.13.2 Power

70.13.2.1 Equipment

- MagSafe-capable device running iOS 16.0 or later.
- MagSafe Certification Assistant app.
- USB-C power adapter supporting at least 22.5 W (2.5 A at 9 V) (if applicable).

70.13.2.2 Procedure

1. Go to: *Settings > Battery > Battery Health* and turn off *Optimized Battery Charging*.
2. Open the *MagSafe Certification Assistant* app on the device.
3. Verify the *battery temperature* and the *battery charge* test requirements are met. They will have green checkmarks.

4. Connect the device to the accessory and verify the charger is detected by the app. It will have a green checkmark.
5. Select *Run Max Power Test*.
6. Verify the test passes.

70.13.3 Low Battery

70.13.3.1 Equipment

- MagSafe-capable device running iOS 16.0 or later.
- USB-C power adapter supporting at least 22.5 W (2.5 A at 9 V) (if applicable).

70.13.3.2 Test Conditions

- Device battery charge level of 0%.
- Ambient temperature of 22 °C to 25 °C.

70.13.3.3 Procedure

1. Drain the battery of the device to 0%. (Play a video at maximum brightness with the flashlight on.)
2. Once the device battery is depleted, wait for at least 30 minutes to allow the device to cool.
3. Verify the ambient temperature is within the range.
4. Connect the device to the accessory and measure the time until the device boots.
5. Verify the boot time is within 15 minutes.