



FALCON RIDGE
2515 Bypass Rd Flemingsburg, KY 41041
(606) 845-7439

Instructions for Installation and Care of
Kawasaki Pro FXT
Full Cab FITS Polycarbonate Windshield
KAW-PROFXT-FC05

Notice: Do not smoke inside the cab or expose the enclosure to direct flames. Cab is Flammable.

Be sure to read these instructions thoroughly before opening and installing the Kawasaki Pro FXT Full Cab FITS Poly Windshield. The installation is best done when the temperature is 70 degrees F. or warmer. The temperature affects the adhesive Velcro, if conditions prevent installing in warmer weather it helps to store the adhesive Velcro at room temperature prior to installation.

1. Carefully open the carton and remove the enclosure on a large flat surface that is clean and free of dirt. Check over the parts included in the carton with the parts list shown below:

Front & Rear Doors

Adhesive Velcro Hook Strips:	32 each-----3”
“ “ “ “	2 each-----8”
“ “ “ “	2 each-----32”
“ “ “ “	2 each-----36”

Middle Rear Window

“ “ “ “	2 each-----45”
“ “ “ “	1 each-----48”
“ “ “ “	1 each-----60”

Rear Window

“ “ “ “	2 each-----13”
“ “ “ “	1 each-----48”
“ “ “ “	1 each-----53”

Top Cap

31" Webbing Strap w/ Grommet	2 each
31" Webbing Straps w/ Loop	2 each
31" Webbing Straps w/ Velcro	2 each
Adhesive Hook Strips	6 each-----6”
Snap studs	5 each (1 extra)
Cab Enclosure	7 panels

The cab will be put together using the following parts and in this order.

- 1 Front Doors
- 2 Middle Rear Window
- 3 Rear Doors
- 4 Rear Window
- 5 Top Cap

FRONT DOORS

2. Begin by installing the front doors. If possible, have someone else hold the door in place and mark the location of each Velcro strip sewn along the **top and front** edges of the door. Now take the supplied 3" adhesive Velcro strips and wrap them around the roll cage at the marked locations. Now put the door back onto the vehicle and wrap the double-sided Velcro around the adhesive Velcro as shown in the photo below.



3. The rear edge of the front door also has double-sided strips, but you do not use the 3" adhesive strips for it. Instead place the 45" adhesive strips down the backside of the middle bar facing the rear of the vehicle. You will need to cut the adhesive strip and place part of it above and below the mount for the bar as shown in the photo. This will hold both the double-sided straps and the sides of the middle rear window in place. See photo below.



4. The diagrams below show how the double-sided straps and the 3" adhesive Velcro works.

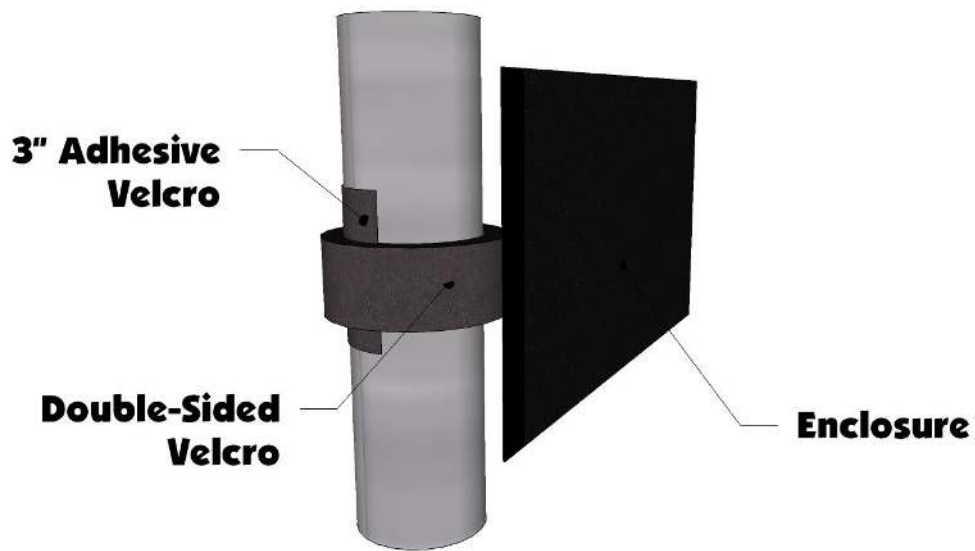
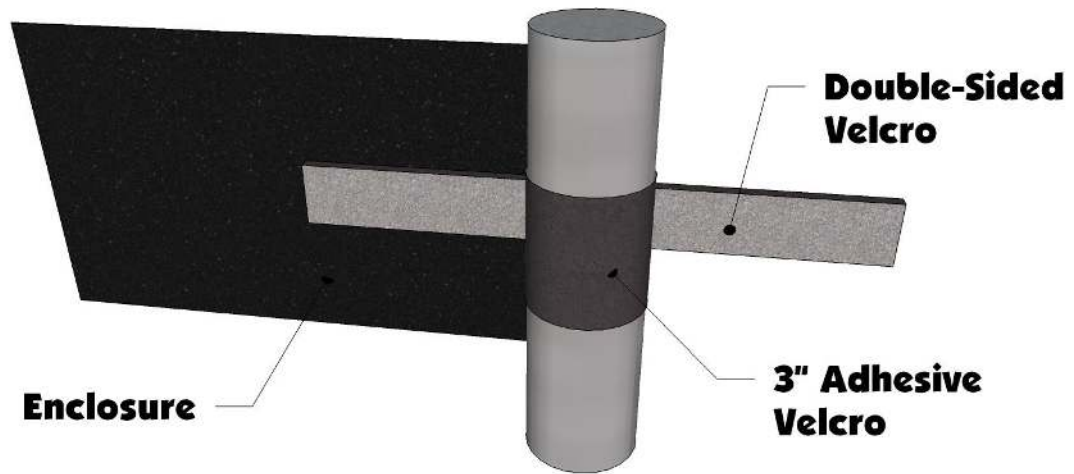

5. The front bottom corner of each door is held in place by one of the 10" adhesive Velcro strip. The photo below shows the proper placement.



6. Finish off the bottom of each door with the one 32" adhesive Velcro Strip. See photo below.



MIDDLE REAR WINDOW

7. The middle rear window is put in place by the 48" adhesive Velcro strip across the top and the 60" adhesive strip across the bottom. The sides are already in place. Place the two strips on the vehicle as shown in the following pictures. The sides will be held in place by the 45" strips that you placed there to hold the rear edge of the doors.



REAR DOORS

8. The rear doors attach the same way along the top. The bottom has two snaps that will go on the inside of the door. **INSTALL NOTE:** to insure proper placement of the snap studs snap them into the sockets on the soft door first. Then zip the door shut and push the end of the screw into the plastic so that a mark is left. Then pull the snap stud back out of the socket and screw them into the inside of the door where the marks are. The front edge attaches to the Velcro strip sewn down the rear edge of the front door. The top and rear edges have the same double-sided Velcro strips that wrap around the roll cage. See photos below.

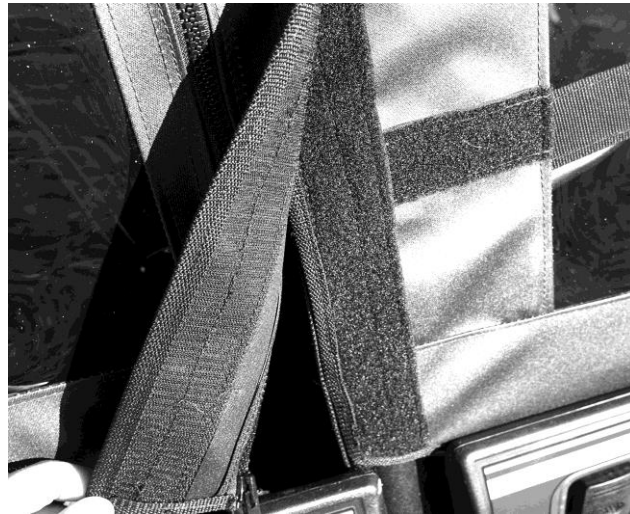

REAR WINDOW

9. The rear window attaches to the movable rear panel. Before placing the rear window on the panel, adhere the 48" adhesive strip across the top and the two 13" strips down the sides (one on each side) as shown in the following pictures.



10. Now line up the rear window on the panel and attach it across the top and sides. The bottom of the rear window uses the 60" adhesive Velcro strip and should be attached to the panel the line up with the Velcro sewn along the bottom of the rear window as shown in the picture below.

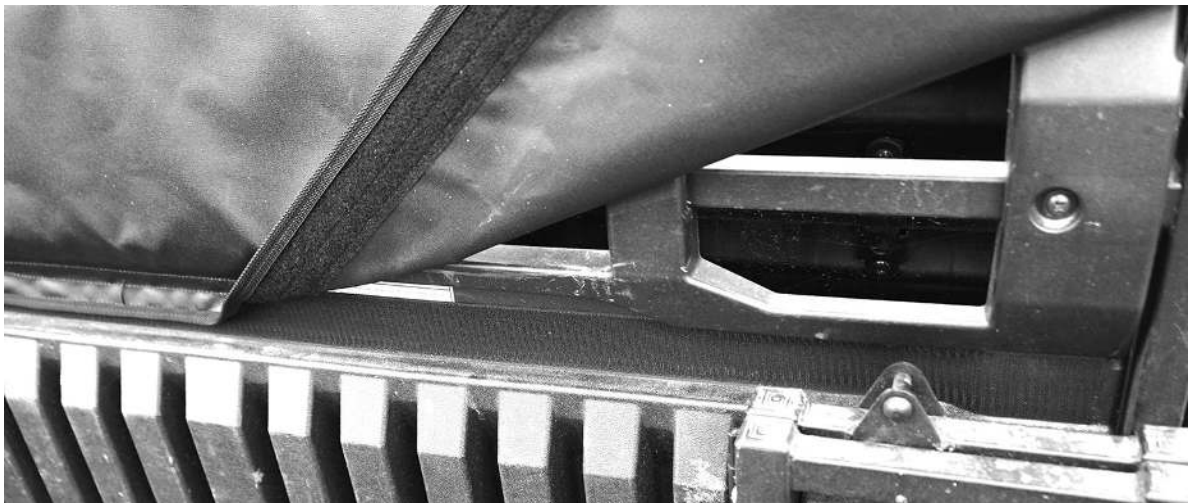

TOP CAP

11. The last item to install is the Top Cap. You have been supplied with 6 straps, but in this case you will only be using 4 of them. Which ones you use will depend on what type of Windshield you have. If your windshield has bolts and clamps holding it to the frame you may be able to use the straps with grommets. Otherwise you will need to use the straps with Velcro. We will start with describing what to do if you have a windshield that allows you to use the straps with grommets in them.
12. Place the Top Cap over the vehicle with the short end towards the front. Remove the thumb nuts that hold the bottom of the top windshield section. Then place the grommet over the bolt and replace the thumb nut so the strap is pointed upwards as shown in the photo below.



13. If you have to use the straps with Velcro, just find a clear spot on the bar and wrap it with a 6" piece of adhesive Velcro and then wrap the double-sided strip around that so that it is held firmly in place. The picture below shows how it should look.



14. The rear of the Top Cap is held in place using the straps that have a loop sewn in one end. Take the end of the strap with the loop and put it under the bed rail just behind the support bar. Then take the other end of the strap and run it through the loop, pulling it tight. The photo below shows what it should look like.

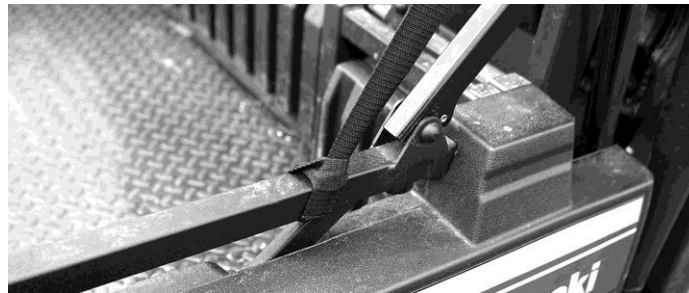

15. Once all the straps are in place run them through the buckles. Pull them tight making sure the top is centered and the side seams line up correctly along the roll cage. The diagram below shows how to lace the webbing through the buckle.

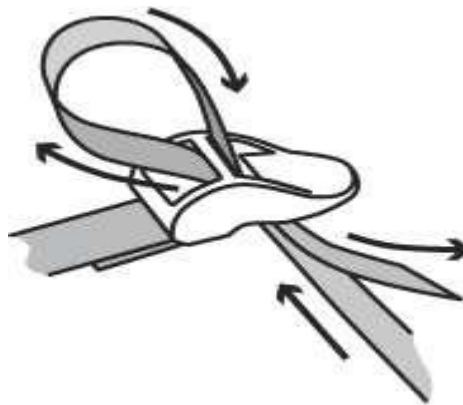

16. Once the front and rear of the Top Cap are pulled tight the next thing is to make sure the middle of the sides are attached to the Velcro sewn to the top of the rear door. The photo below shows this.

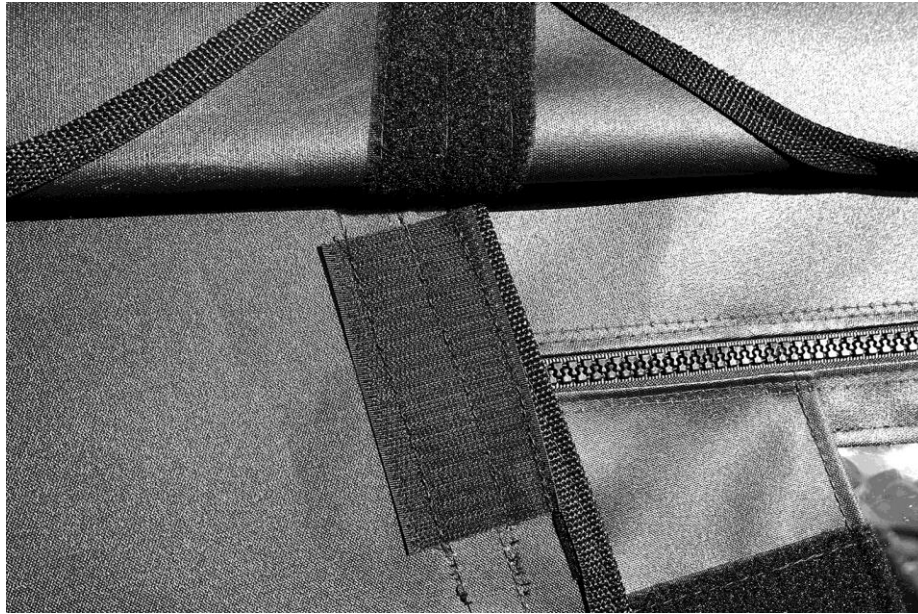

17. Now that the Top Cap is all in place the only remaining thing is to attach the Top Cap to the top of the Windshield using the long piece of Velcro included.

Cleaning and Storage Recommendations:

1. Before removing the Falcon Ridge Cab for storage, make sure it is very clean in order to prevent scratching of the window panels. Clean with a soft rag or sponge using a mild liquid detergent soap and warm water solution. Never rub the windows with a dry cloth or rag! Let the Cab dry thoroughly before attempting to roll for storage.
2. It is important that the Cab be rolled up for storage rather than folding. Folding will cause damage to the windows!!! Carefully roll up the Cab similar to the way it was when it was packed at the factory. On a large, clean and flat surface, fold the doors over the rear panel first, then, interleave the top and windshield on top of the doors. Begin rolling the Cab into a roll approximately 8 inches in diameter. Put the rolled Cab back into the carton for storage at a normal room temperature. It is best not to expose the Cab to either extreme hot or cold temperatures when storing.
3. A special cleaner conditioner is available from Falcon Ridge that will greatly increase the service life of the Cab Enclosure. If additional hook and loop sets are needed, they can also be ordered.

Return Policy

If for any reason you choose to return this product it must be returned within **30 days from date item is received**. You **MUST** package the product exactly **as it was originally packaged from the factory to get a full refund for the product!**

The vinyl windows should never be folded when packaging in the box or for storage purposes. Lay all the windows on top of each other with the canvas folded in between and the paper (if available) on both sides of the windows.

All returned products will be inspected upon arrival at the production facility and must be in unused, factory new condition to receive refund - a 25% restocking fee will apply.

If ordered from Falcon Ridge please call at 606-845-7439 to gain a return authorization number, use our preferred shipping carrier (UPS) to return the item (unless the item is defective, you are responsible for paying the shipping to return the item.) **Any returns submitted to Falcon Ridge without a return authorization number will be charged a 20% restocking fee.** If ordered from one of Falcon Ridges many distributors', you must first call them and see what their return policy is. Once your item reaches our production facility, our customer satisfaction team will inspect your item to ensure unused, factory new condition. **NOTE: All windshields must be returned with the original protective film intact and not removed. Do NOT REMOVE if you have any intentions of returning the item. Refund/ replacement of a windshield will only be processed on items with original protective film or if the windshield is defective.**

Items must be properly packaged in the original shipping carton to protect them during transit and ensure your returned item arrives back factory fresh, and in new resalable condition (**any returned items that have been used, altered or damaged in any way will not be subject for a refund.**) All contents including instruction manuals, accessories, hardware, Velcro, etc. must be included in your return shipment. Only items in OEM factory new condition will be approved. Once returned items are received, credit will be issued to the original credit card/ payment method used for the purchase. Outbound shipping and return shipping cost will not be refunded. Please allow 4 to 6 weeks for your refund to be processed.

Warranty

To The Owner of this Product:

Thank you for purchasing one of Falcon Ridge Cab Enclosures, Tops &/or Windshields! Below are the terms under which your product is covered under our manufacturer's warranty.

30 Day Warranty which includes and is not limited to replacing the enclosure, tops and/or windshield due to defect of the product. Please refer to the return policy in this case for more information.

1 Year Warranty includes any defect in material or workmanship within this time frame we will gladly correct the problem or replace the enclosure, tops &/or windshield. Upon submitting for the correction or replacement we will need to receive pictures of the defect in material or workmanship along with the receipt from the date of purchase.

Thank you,

Falcon Ridge