



FZV 2102-E

English	3-16
Čeština.....	17-30
Slovenčina	31-44
Magyarul	45-58
Polski	59-72

ELECTRIC SCARIFIER

USER'S MANUAL

Dear customer,

thank you very much for the trust that you have expressed!

Before putting this machine into operation, it is imperative to read this user's manual! In it, you will find all the instructions for normal operation and for achieving a long lifetime of the machine. It is imperative to adhere to all safety instructions contained in this user's manual.

CONTENTS

1. GENERAL SAFETY INSTRUCTIONS	4
2. SYMBOLS.....	4
3. SAFETY INSTRUCTIONS.....	6
4. PURPOSE OF USE	7
5. DESCRIPTION OF THE MACHINE	8
6. ASSEMBLING THE MACHINE.....	9
7. REPLACING BLADES	11
8. SETTING UP THE SCARIFIER	12
9. PUTTING INTO OPERATION.....	12
10. MAINTENANCE	13
11. SCARIFICATION / AERATION	13
12. TECHNICAL SPECIFICATIONS.....	14
13. DISPOSAL.....	15

1. GENERAL SAFETY INSTRUCTIONS

Important safety notice

- ✿ Carefully unpack the product and take care not to throw away any part of the packaging before you find all the parts of the product.
- ✿ Store the product in a dry place out of reach of children.
- ✿ Read all warnings and instructions. Not following warnings or instructions may lead to injury by electrical shock, a fire and/or serious injuries.

Packaging

- ✿ The product is packed in a package that prevents damage during transport. This package is a resource and so can be handed over for recycling.

User's Manual

- ✿ Before you start working with the machine, read the following safety and usage instructions. Acquaint yourself with the operating elements and the correct use of the machine. Keep the user's manual in a safe place where it can be easily retrieved for future use. Save the original packaging, including the internal packing material, warranty card and proof of purchase receipt at least for the duration of the warranty.
- ✿ If you need to ship this machine, pack it in the original cardboard box to ensure maximum protection during shipping or transport (e.g. when moving or when you need to send this product for repair).

 **NOTE:** If you hand over the machine to somebody else, do so together with this user's manual.









- ✿ Following the instructions in the included user's manual is a prerequisite for the proper use of the machine. The user's manual also contains operating, maintenance and repair instructions.
- ✿ The manufacturer takes no responsibility for accidents or damages resulting from not following the instructions in this manual.

2. SYMBOLS

 **ATTENTION!** Before putting into operation, carefully read the user's manual and the general safety instructions!

Do not work in the rain or in unfavourable climatic conditions!

 **ATTENTION!** The blade of the scarifier continues to rotate for some time after it is turned off!
Keep a safe distance!
Attention, rotating blades!

	<p>Attention! Before putting into operation, carefully read the user's manual and the general safety instructions!</p>
	<p>Do not work in the rain or in unfavourable climatic conditions!</p>
	<p>Attention, the blade of the scarifier continues to rotate for some time after it is turned off!</p>
	<p>Keep the power cable at a safe distance from the blade.</p>
	<p>Keep a safe distance!</p>
	<p>Attention, rotating blades! Sharp blade/s. Protect yourself against injury and loss of fingers.</p>
	<p>While working use protective aids.</p>
	<p>Before setting up the machine or carrying out maintenance on the machine, or if the power cord has become jammed or is damaged, always turn off the motor and pull the plug out of the power socket!</p>

3. SAFETY INSTRUCTIONS

Thank you for purchasing this garden scarifier. Before you start using it, please carefully read this user's manual and save it for possible future use.

Checks before every use

- ✿ Check the electric scarifier before every use.
- ✿ Do not use the electric scarifier if the safety mechanisms (start lever, safety brake, rear lid or cover) are damaged or worn out.
- ✿ Never use the machine with a blocked or missing safety mechanism.

 **NOTE:** Make sure that all nuts and bolts are pulled tight and that the scarifier is in good operating condition.

- ✿ Before starting work, inspect the area that is to be aerated. Check the work area for any foreign objects (e.g. stones, branches, rope) and remove them if necessary.

Proper use / Responsibility

 **ATTENTION!** Danger! Danger of injury! The scarifier may cause serious injuries!

- ✿ Do not place hands or feet near the scarification cylinder.
- ✿ You are responsible for the safety of the methods of use described in these instructions.
- ✿ Work only under good visibility.
- ✿ Do not open the rear cover during use.
- ✿ Acquaint yourself with the surroundings of your work area. Check for potential dangers, which may not be audible due to the noise of the machine.
- ✿ Wear solid footwear and long pants to protect your legs.
- ✿ Make sure that your legs are at a sufficient distance from moving parts.
- ✿ Make sure that there are no other people (particularly children) or animals in the work area.
- ✿ Always push the scarifier at walking speed.
- ✿ Operating position: make sure that you have safe foot support during operation.
- ✿ Be especially careful when changing direction on a slope.

 **ATTENTION!** Be extremely careful when walking backwards. You could stumble!

- ✿ Do not use the electric scarifier in the rain or in damp or wet conditions.
- ✿ Do not work with the scarifier near the edges of swimming pools or garden ponds.
- ✿ Please adhere to all local restrictions related to noise levels.

Interrupting work

 **ATTENTION!** Never leave the electric scarifier in the work area without supervision.

- ✿ When you stop working, place the machine in a safe location. Unplug the power plug! If you stop working in order to move to a different work location, always turn the electric scarifier off while carrying it. Move the wear compensation lever into the transport position.
- ✿ In the event that you hit an obstacle while scarifying, turn off the electric scarifier and remove the obstacle. Check the electric scarifier for damage and have it repaired if necessary.

Electrical safety

- ✿ Keep the extension cord away from the scarification cylinder!
- ✿ Never use the electric scarifier in the rain.
- ✿ Please adhere to local residential noise restrictions.
- ✿ It is necessary to regularly inspect the power / extension cord for damage and signs of wear and tear.
- ✿ In the event that the power / extension cord is damaged, immediately unplug the power cord.
- ✿ The socket on the extension cord must be water resistant providing protection against spraying water, or the power sockets for the extension cord must be made from rubber or must have a rubber cover.
- ✿ Extension cords must meet the requirements of DIN VDE 0620.
- ✿ Only use approved extension cords with the corresponding conductor cross-sections. Please consult your electrician.
- ✿ It is necessary to use connecting accessories for the extension cord.
- ✿ For portable equipment used outdoors, we recommend the use of a residual current device with a maximum current rating of 30 mA. In Switzerland, the use of a residual current device is compulsory.

4. PURPOSE OF USE

Intended use

- ✿ The FZV 4003 E Electric Scarifier is designed for aerating lawns and grass areas in private gardens and yards. It is not intended for use in public facilities, parks, sports fields, on roads, in agriculture or forestry.

⚠ ATTENTION! To prevent injury, the electric scarifier must not be used for trimming shrubs, hedges and bushes. Furthermore, the electric scarifier must not be used for levelling uneven terrain.

5. DESCRIPTION OF THE MACHINE (FIG. 1)

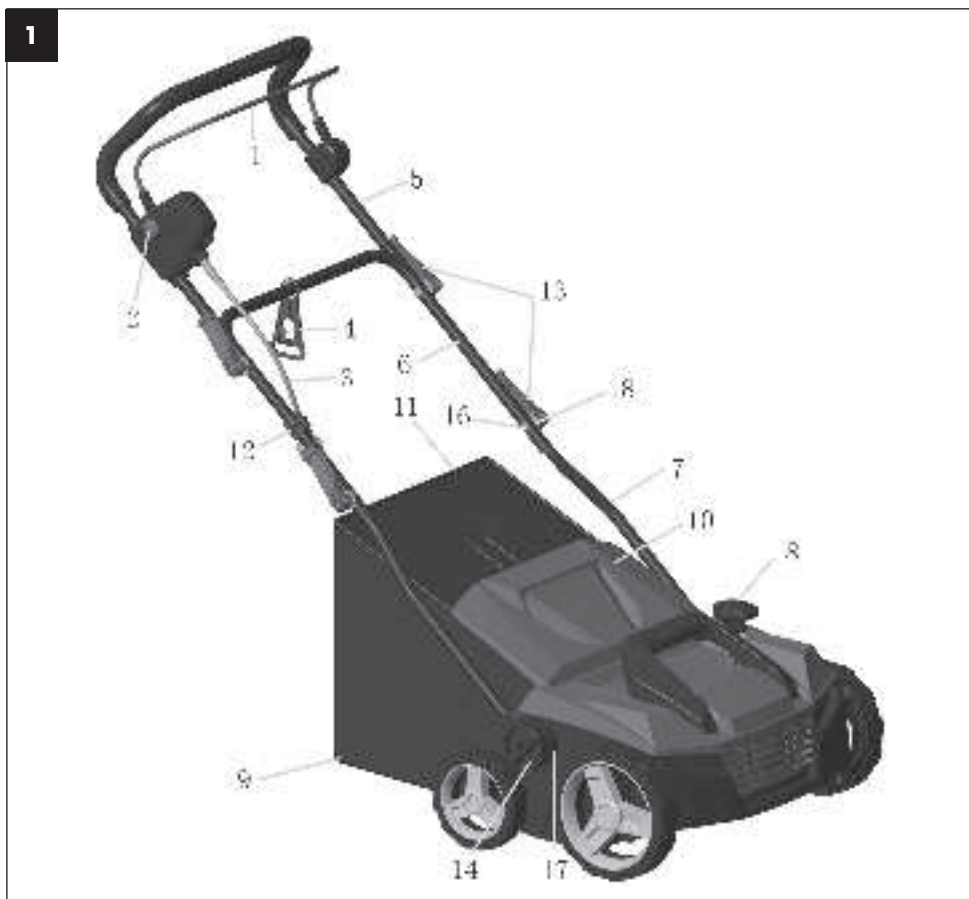

- | | |
|------------------------------------|----------------------------------|
| ① Main switch | ⑩ Basket cover |
| ② Main switch safety lock | ⑪ Grass catcher frame |
| ③ Power cord | ⑫ Cable clip |
| ④ Power cord retainer hook | ⑬ Quick-acting lever |
| ⑤ Top part of the handle | ⑭ Bottom handle screw |
| ⑥ Middle part of the handle | ⑮ Handle screw |
| ⑦ Bottom part of the handle | ⑯ Handle height adjustment thorn |
| ⑧ Working depth adjustment control | ⑰ Handle screw washer |
| ⑨ Basket | |

6. ASSEMBLING THE MACHINE

1. Attach the handle's bottom parts (fig.2, point 7) using the screw (point 14). Adjust the required handle height using the XZN spline (point 17).

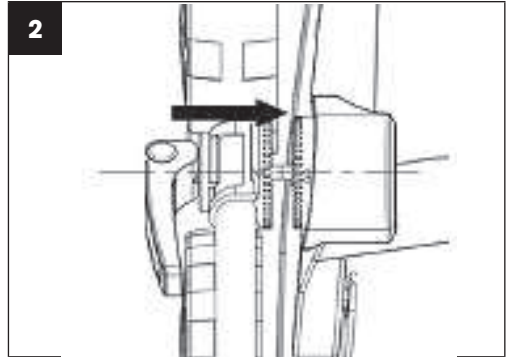

2. Screw on the handle's middle part with the power cord safety clamp attached using the fast coupling lever and the handle screw (fig. 3).



3. Screw on the handle's top part (fig. 4).
4. Attach the power cord to the handle using the plastic clips (fig.5).

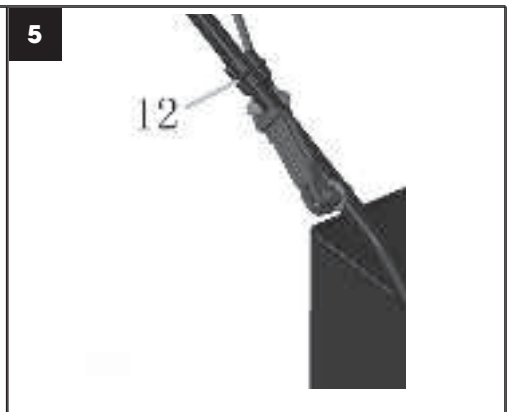

5. Place the steel frame ⑩ into the textile collection basket ⑨ and attach all fastener to the left, right and rear poles of the frame. Make sure that all fasteners are secured correctly (fig. 6).

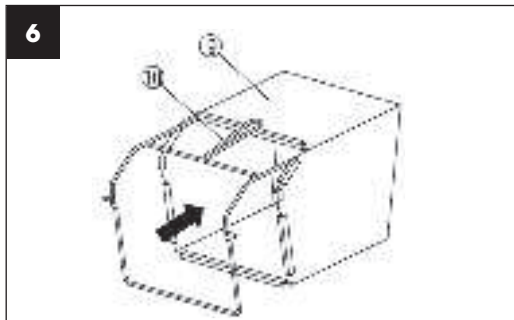

6. Installation of the completely assembled collection basket on to the scarifier (fig. 7).
- Lift up the protective cover ⑪.
 - Make sure that the ejection chute is clear and free of debris.
 - Place the fully assembled collection basket on to the fastening points in the rear part of the chassis, as shown.
 - Place the protective cover ⑪ on top of the collection basket. Check that the collection basket is seated correctly.



 **NOTE:** For use without the grass catcher, the lawnmower may be used without the collection basket with the protective cover ⑪ in the lower position.

7. REPLACING BLADES

⚠ DANGER!

The cylinders may cause injuries!

Prior to replacement, disconnect the machine from the power grid and wait for the cylinder to come to a stop.
When replacing, wear work gloves.

1. Screw out bolt ① on the underside of the chassis (fig. 8).

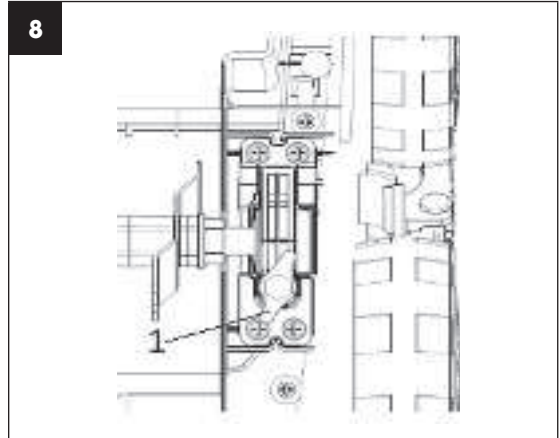

2. Lift the cylinder ③ at an angle and pull it out (fig. 9).

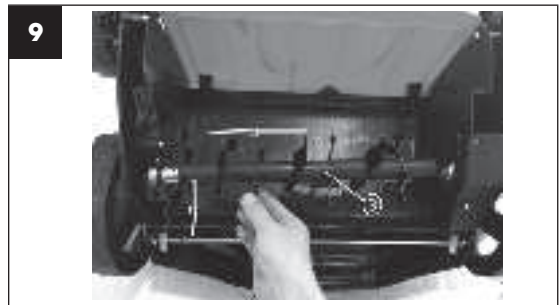

3. Slide the second cylinder on to the drive shaft so that the pin ⑤ fits into the respective part of the drive shaft ④ (fig. 10).
4. Tighten the screw ① to secure again (fig. 8)

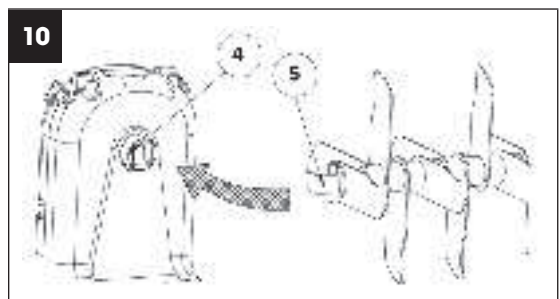

8. SETTING UP THE SCARIFIER

⚠ ATTENTION!

The working depth with the scarification cylinder should be no more than 3 mm. The aeration cylinder with springs should copy the contour of the ground during operation. Setting an excessive working depth may even without visible wear on the blades/springs result in damage to the scarification cylinder or the overloading and destruction of the motor. **The lawn may also be damaged.**

Adjustment after wear

To maintain the recommended working depth, use the working depth adjustment control (fig. 1, point 8).

NOTE: The blades and springs of the scarifier wear out depending on the manner in which they are used. The more intensively the scarifier is used, the greater the wear on the blades and springs. Hard or very dry ground accelerates the wearing out process as does excessive use. In the event that, as a result of wear on the blades, the results of your work with the scarifier worsen, it is possible to adjust the scarification cylinders so that the working depth is constantly kept at the above-described depth.

9. PUTTING INTO OPERATION (FIG. 11)

Before starting it up again, check that the blade has come to a complete stop. Do not turn on and off in rapid succession.

Starting

1. Press and hold the safety button ①. Pull the starting lever ② to the handle.
2. Release the safety button.

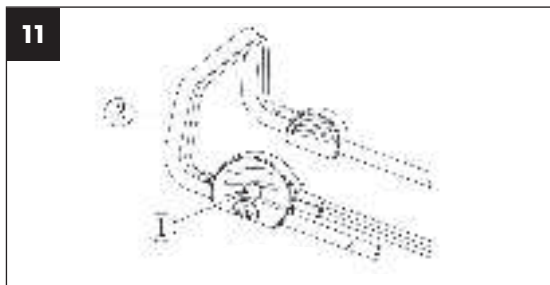

Turning off

Release the starting lever ②.

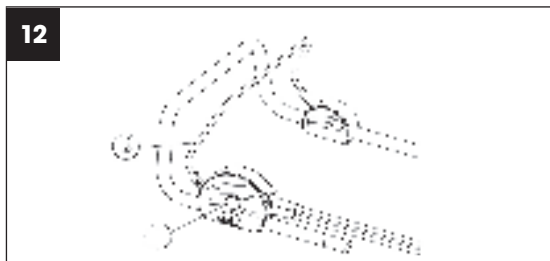

10. MAINTENANCE

Cleaning the scarifier

- ⚠ **ATTENTION!** Danger! A rotating blade may cause injuries.
- ⚠ **ATTENTION!** Prior to maintenance, disconnect the machine from the power grid and wait for the scarification cylinder to come to a stop.
- ⚠ **ATTENTION!** While performing maintenance use work gloves.
- ✿ The scarifier should be cleaned after every use.
- ⚠ **ATTENTION!** Risk of injury and material damage.
- ⚠ **ATTENTION!** Do not clean the scarifier under running water (especially not under high pressure).
- ⚠ **ATTENTION!** Do not use hard or pointed items for cleaning the scarifier.
- ✿ Remove grass and accumulated debris from the wheels, scarification cylinder and the cover.

11. SCARIFICATION / AERATION

- ✿ For comfortable work with the scarifier, it is best to start working at the location closest to the power source and to proceed away from the power source.
- ✿ Scarify / aerate the lawn at a right angle from the power source and place the power cord on the side that has already been treated.
- ⚠ **ATTENTION!** Do not place too much strain on the motor when working, especially in demanding conditions. When the motor is put under strain, the motor speed will decline and you will hear a change in the noise of the motor. Whenever this happens, stop working, release the starting lever and reduce the scarification / aeration depth. Otherwise the machine could be damaged.
- 📖 **NOTE:** The motor is protected by a safety mechanism that is activated at the instant that the blades are caught or the engine is overloaded. Whenever this occurs, turn the machine off and pull the power plug out of the power source. The safety mechanism will reset only when the starting lever is released. Remove all obstacles and wait several minutes before resetting the safety mechanism and resuming work. At this point, do not play with the starting lever as this will extend the safety mechanism reset time. In the event that the machine turns off again, raise the height of scarification / aeration again, which will reduce the load on the motor.

12. TECHNICAL SPECIFICATIONS

Electric scarifier	FZR 2102-E
Rated power	1300 W
Working width	32 cm
Working depth	+10 to -12 mm
Collection basket capacity	40 l
Weight.....	11,0 kg
Protection class	IPX4
Cylinder operating speed	3 600 rpm
Sound pressure level	$L_{pa} = 75,9 \text{ dB(A)}$
Guaranteed sound power level	$L_{wa} = 96 \text{ dB(A)}$
Vibrations	$3,6 \text{ m/s}^2 \text{ K}=1,8 \text{ m/s}^2$

13. DISPOSAL

INSTRUCTIONS AND INFORMATION REGARDING THE DISPOSAL OF USED PACKAGING MATERIALS

Dispose of used packaging material at a site designated for waste in your municipality.



The power tool and its accessories are manufactured from various materials, e.g. metal and plastic. Take damaged parts to a recycling centre. Inquire at the relevant government department.



This product meets all the basic requirements of EU directives that apply to it.

Changes in the text, design and technical specifications may be made without prior notice and we reserve the right to make these changes.

Translation of the original user's manual.

