

Installation and Operation Manual

**24k -48k BTU
Single Zone
Outdoor Condenser
230 Volts
R- 454B Refrigerant**

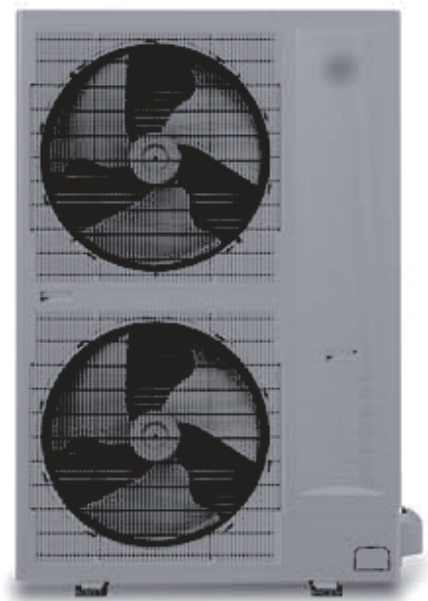

Model	For use in Model Sets as listed Below			
	Wall Mounted	Cassette	Concealed Ducted	AHU
FPHFR24A3D	FXHW243D	FPHC243D	FPHD243D	FPHFA18A3D FPHFA24A3D
FPHFR36A3D	-	FPHC363D	FPHD363D	FPHFA36A3D
FPHFR48A3D	-	-	-	FPHFA48A3D

Contents

Safety Precautions	1
Electrical Wiring Diagram	9
Installation Instructions	10
Transportation and Handling before Installation	10
Installation Location Selection.....	10
Drainage Elbow and Drain Hose Installation	11
Outdoor Unit Installation.....	11
Refrigerant Piping	12
Wiring	18
Test Run	21

NOTE:

- This air conditioner is designed for the following temperatures.
It should be operated within this range:

Capacity (Btu/h)	Mode	Outdoor operation temperature range [°F (°C)]	
		Maximum	Minimum
24K~48K	Cooling Operation	125(52)	5(-15)
	Heating Operation	75(24)	-22(-30)

- Storage condition: Temperature -13~140°F (-25~60°C)
Humidity 30%~80%
- The capacity on the outdoor unit's label is its rated capacity. The actual capacity of the entire unit, when paired with a different indoor unit, will be determined by the capacity on the indoor unit's label.

Safety Precautions

1. This air conditioner uses new refrigerant HFO (R454B). R454B refrigerant is flammable.
 2. HFC R454B is different from HFC R22 / R410A/ R32, some of the piping and installation and service tools are special.
 3. This air conditioner uses power supply: 208/230V ~, 60Hz.
 4. Specified filter drier is required on the liquid pipe when installing AHU units.
 5. Be sure that servicing equipment and replacement components are applicable for R454B refrigerant.
 6. Do not discharge R454B refrigerant into the air, and when recover it, the cylinder service pressure rating must be over 600 psig. R454B refrigerant systems should be charged with liquid refrigerant and the service pressure rating of the hoses used must be over 750 psig.
 7. Leak detectors should be designed to detect HFC refrigerant.
 8. R454B refrigerant is only compatible with POE oils, which could absorb moisture rapidly, so do not expose it to the air, in case that it damages certain plastics materials.
 9. Replace all the filter driers after maintenance.
Please read these SAFETY PRECAUTIONS carefully to ensure correct installation.
 - Be sure to use a dedicated power circuit, and do not put other loads on the power supply.
 - Be sure to read these SAFETY PRECAUTIONS carefully before installation.
 - Be sure to comply with SAFETY PRECAUTIONS of installation manual, because it contains important safety issues. Definitions for identifying hazard levels are provide below with their respective safety symbols.
- ⚠ **WARNING:** Hazards or unsafe practices which COULD result in severe personal injury or death.
- ⚠ **CAUTION:** Hazards or unsafe practices which COULD result in minor personal injury or product or property damage.
- Please carefully file indoor and outdoor unit manual away for future reference.

WARNING

- Installation should be performed by qualified personnel.
Improper installation may cause water leakage, electrical shock or fire.
- Install the air conditioner on a solid base that can support the unit weight.
An inadequate base or incomplete installation may cause injury if the unit falls off the base.
- Use the specified type of wire for electrical connections safely between the indoor and outdoor units.
And firmly clamp the interconnecting wires so their terminals receive no external stresses.
- For wiring, use a cable long enough to cover the entire distance with no connection.
And do not connect multiple devices to the same AC power supply.
Otherwise, it may be due to bad contact, poor insulation, exceed the allowable current and cause a fire or electric shock.
- After all installation is completed, check to make sure that no refrigerant is leaking out.
If the refrigerant gas leakage to the interior, and the heater, stove flame touching it, will generate harmful substances.
- Perform the installation securely referring to the installation manual.
Incomplete installation could cause a personal injury due to fire, electric shock, the unit falling or leakage of water.
- In accordance with the installation instructions for electrical work, please be sure to use a dedicated line.
- If the power supply circuit capacity or electrical work is not in place, may cause a fire or electric shock.
- Attach the electrical cover to the indoor unit and the service panel to the outdoor unit securely.
- If the electrical covers on the indoor unit or the service panel of the outdoor unit are not attached securely, it could result in a fire or an electric shock due to dust water, etc.
- Please be sure to cut off the main power supply before the installation of indoor electronic PCB or wiring. Otherwise, it will cause electric shock.
- The device should be in accordance with the state provisions for installation wiring.

Safety Precautions

- The outdoor machine installation location should pay attention to the protection, avoid people or other small animals contact with electrical components, please keep the outdoor unit of the surrounding environment clean and tidy.
- When installing or relocating the unit, make sure that no substance other than the specified refrigerant (R454B) enters the refrigerant circuit.
Any presence of foreign substance such as air can cause abnormal pressure rise or an explosion.



- Perform grounding
Does not connect the earth wire to a gas pipe, water pipe, lightning rod or telephone earth wire.
Defective grounding could cause an electric shock.
- Do not install the unit in a place where an inflammable gas leaks.
If gas leaks and accumulates in the area surrounding the unit, it could cause an explosion.
- Fasten a flare nut with a torque wrench as specified in this manual.
When fastened too tight, a flare nut may break after a long period and cause a leakage of refrigerant.
- Install an earth leakage breaker depending on the installation place (where it is humid).
If an earth leakage breaker is not installed, it could cause an electric shock.
- Perform the drainage/piping work securely according to the installation manual.
- If there is a defect in the drainage/piping work, water could drop from the unit and household goods could be wet and damaged.

Safety instructions

- Do not let air enter the refrigeration system or discharge refrigerant when moving the air conditioner.
- This appliance is not intended for use by persons (including children) with reduced physical, sensory or mental capabilities, or lack of experience and knowledge, unless they have been given supervision or instruction concerning use of the appliance by a person responsible for their safety.
- Children should be supervised to ensure that they do not play with the appliance.
- The appliance shall be installed in accordance with national wiring regulations.
- Servicing shall only be performed as recommended by the equipment manufacturer.
- Maintenance and repair requiring the assistance of other skilled personnel shall be carried out under the supervision of the person competent in the use of flammable refrigerants.
- Means for disconnection, such as circuit breaker, which can provide full disconnection in all poles, must be incorporated in the fixed wiring in accordance with the wiring rules.
It is necessary to allow the disconnection of the appliance from the supply after installation.
Make sure the disconnection of the appliance from the supply when service and maintenance, a disconnection with a locking system in the isolated position shall be provided.
- The method of connection of the appliance to the electrical supply and interconnection of separate components, and the wiring diagram with a clear indication of the connections and wiring to external control devices are detailed in below parts.
- Details of type and rating of circuit breakers / ELB is detailed in below parts.
- The information of dimensions of the space necessary for correct installation of the appliance including the minimum permissible distances to adjacent structures is detailed in below parts.
- This appliance is intended to be used by expert or trained users in shops, in light industry and on farms, or for commercial use by lay persons.
- Instructions on additional charging of refrigerants are detailed below.
- Assure that the maximum operating pressure is considered when connecting to any indoor unit.
- Assure that the units shall only be connected to an appliance suitable for the same refrigerant.
- This unit must only be connected to other units that have been confirmed as complying to corresponding PARTIAL UNIT requirements of this Standard, UL 60335-2-40/CSA C22.2 No. 60335-2-40, or UL 1995/CSA C22.2 No. 236.

Precautions for using R454B refrigerant

The basic installation work procedures are the same as the conventional refrigerant (R22 or R410A). However, pay attention to the following points:

WARNING

1. Transport of equipment containing flammable refrigerants.

Attention is drawn to the fact that additional transportation regulations may exist with respect to equipment containing flammable gas. The maximum number of pieces of equipment or the configuration of the equipment, permitted to be transported together will be determined by the applicable transport regulations.

2. Marking of equipment using signs

Signs for similar appliances (containing flammable refrigerants) used in a work area generally are addressed by local regulations and give the minimum requirements for the provision of safety and/or health signs for a work location. All required signs are to be maintained and employers should ensure that employees receive suitable and sufficient instruction and training on the meaning of appropriate safety signs and the actions that need to be taken in connection with these signs. The effectiveness of signs should not be diminished by too many signs being placed together. Any pictograms used should be as simple as possible and contain only essential details.

3. Disposal of equipment using flammable refrigerants

Compliance with national regulations

4. Storage of equipment/appliances

The storage of equipment should be in accordance with the manufacturer's instructions.

5. Storage of packed (unsold) equipment

- Storage package protection should be constructed such that mechanical damage to the equipment inside the package will not cause a leak of the refrigerant charge.
- The maximum number of pieces of equipment permitted to be stored together will be determined by local regulations.
- The storage temperature should not exceed 60°C, as the refrigerant leakage may occur above 140°F (60°C), which can cause danger.

6. Information on servicing

6-1 Checks to the area

Prior to beginning work on systems containing flammable refrigerants, safety checks are necessary to ensure that the risk of ignition is minimized. For repair to the refrigerating system, the following precautions should be complied with prior to conducting work on the system.

6-2 Work procedure

Work shall be undertaken under a controlled procedure so as to minimise the risk of flammable gas or vapour being present while the work is being performed.

6-3 General work area

- All maintenance staff and others working in the local area shall be instructed on the nature of work being carried out. Work in confined spaces shall be avoided.
- The area around the workspace shall be sectioned off. Ensure that the conditions within the area have been made safe by control of flammable material.

6-4 Checking for presence of refrigerant

- The area shall be checked with an appropriate refrigerant detector prior to and during work, to ensure the technician is aware of potentially flammable atmospheres.
- Ensure that the leak detection equipment being used is suitable for use with flammable refrigerants, i.e. non-sparking, adequately sealed or intrinsically safe.

6-5 Presence of fire extinguisher

- If any hot work is to be conducted on the refrigeration equipment or any associated parts, appropriate fire extinguishing equipment shall be available to hand.
- Have a dry powder or CO2 fire extinguisher adjacent to the charging area.

6-6 No ignition sources

- No person carrying out work in relation to a refrigeration system which involves exposing any pipe work that contains or has contained flammable refrigerant shall use any sources of ignition in such a manner that it may lead to the risk of fire or explosion.
- All possible ignition sources, including cigarette smoking, should be kept sufficiently far away from the site of installation, repairing, removing and disposal, during which flammable refrigerant can possibly be released to the surrounding space.
- Prior to work taking place, the area around the equipment is to be surveyed to make sure that there are no flammable hazards or ignition risks. "No Smoking" signs shall be displayed.

6-7 Ventilated area

- Ensure that the area is in the open or that it is adequately ventilated before breaking into the system or conducting any hot work.
- A degree of mechanical ventilation shall continue during the period that the work is carried out.
- The ventilation should safely disperse any released refrigerant and preferably expel it externally into the atmosphere.

6-8 Checks to the refrigeration equipment

- Where electrical components are being changed, they shall be fit for the purpose and to the correct specification.
- At all times the manufacturer's maintenance and service guidelines shall be followed. If in doubt consult the manufacturer's technical department for assistance.

WARNING

- The following checks shall be applied to installations using flammable refrigerants:
 - The charge amount is in accordance with the room size within which the refrigerant containing parts are installed;
 - The ventilation machinery and outlets are operating adequately and are not obstructed;
 - If an indirect refrigerating circuit is used, the secondary circuit shall be checked for the leak of refrigerant;
 - Marking of the equipment should be visible and legible. Illegal markings and signs shall be corrected;
 - Refrigeration pipe or components are installed in a position where they are unlikely to be exposed to any substance which may corrode refrigerant containing components, unless the components are constructed of materials which are inherently resistant to being corroded or are suitably protected against being so corroded.

6-9 Checks of electrical devices

- Repair and maintenance of electrical components shall include initial safety checks and component inspection procedures.
- If a fault exists that could compromise safety, then no electrical supply shall be connected to the circuit until it is satisfactorily dealt with.
- If the fault cannot be corrected immediately but it is necessary to continue operation, an adequate temporary solution shall be used.
- This shall be reported to the owner of the equipment so all parties are advised.
- Initial safety checks shall include:
 - Do not discharge capacitors. Remove power from the unit and check that the LEDs on all PCBs are out before working on the unit.
 - That there no live electrical components and wiring are exposed while charging, recovering or purging the system;
 - That there is continuity of earth bonding.

7. Repairs of sealed components

Sealed electrical components shall be replaced.

8. Repairs of intrinsically safe components

Intrinsically safe components must be replaced.

9. Cabling

- Check that cabling will not be subject to wear, corrosion, excessive pressure, vibration, sharp edges or any other adverse environmental effects.
- The check shall also take into account the effects of aging or continual vibration from sources such as compressors or fans.

10. Detection of flammable refrigerants

- Under no circumstances shall potential sources of ignition be used in the searching or detection of refrigerant leaks.
- A halide torch (or any other detector using a naked flame) shall not be used.

11. Leak detection methods

The following leak detection methods are deemed acceptable for systems containing flammable refrigerants:

- Electronic leak detectors shall be used to detect flammable refrigerants, but the sensitivity may not be adequate, or may need re-calibration. (Detection equipment shall be calibrated in a refrigerant-free area.)
- Ensure that the detector is not a potential source of ignition and is suitable for the refrigerant used.
- Leak detection equipment shall be set at a percentage of the LFL of the refrigerant and shall be calibrated to the refrigerant employed and the appropriate percentage of gas (maximum 25%) is confirmed.
- Leak detection fluids are suitable for use with most refrigerants but the use of detergents containing chlorine shall be avoided as the chlorine may react with the refrigerant and corrode the copper pipe-work.
- If a leak is suspected, all naked flames shall be removed/ extinguished.
- If a leakage of refrigerant is found which requires brazing, all of the refrigerant shall be recovered from the system, or isolated (by means of shut off valves) in a part of the system remote from the leak.
- Removal of refrigerant shall be according to the manual.

WARNING

12. Removal and evacuation

- When breaking into the refrigerant circuit to make repairs – or for any other purpose –conventional procedures shall be used.
- However, for flammable refrigerants it is important that best practice be followed, since flammability is a consideration.
- The following procedure shall be adhered to:
 - Safely remove refrigerant following local and national regulations;
 - Evacuate;
 - Purge the circuit with nitrogen
 - Evacuate
 - Cut out components to open circuit, do not use flame.
 - Open the circuit.
- The refrigerant charge shall be recovered into the correct recovery cylinders.
- The system shall be “flushed” with OFN to render the unit safe.
- This process may need to be repeated for several times.
- Compressed air or oxygen shall not be used for this task.
- Flushing shall be achieved by breaking the vacuum in the system with OFN and continuing to fill until the working pressure is achieved, then venting to atmosphere, and finally pulling down to a vacuum.
- This process shall be repeated until no refrigerant is within the system. When the final OFN charge is used, the system shall be vented down to atmospheric pressure to enable working.
- This operation is absolutely vital if brazing operations on the pipe-work are to take place.
- Ensure that the outlet for the vacuum pump is not close to any ignition sources and there is ventilation available.

13. Charging procedures

- In addition to conventional charging procedures, the following requirements shall be followed:
 - Ensure that contamination of different refrigerants does not occur when using charging equipment.
 - Hoses or lines shall be as short as possible to minimise the amount of refrigerant contained in them.
 - Cylinders shall be kept upright.
 - Ensure that the refrigeration system is earthed prior to charging the system with refrigerant.
 - Label the system when charging is complete (if not already).
 - Extreme care shall be taken not to overfill the refrigeration system.
 - Prior to recharging the system pressure shall be tested with OFN.
- The system shall be leak tested on completion of charging but prior to commissioning.
- A follow up leak test shall be carried out prior to leaving the site.

14. Decommissioning

Before carrying out this procedure, it is essential that the technician is completely familiar with the equipment and all its detail.

It is recommended that all refrigerants are recovered safely.

Prior to the task, an oil and refrigerant sample shall be taken in case that an analysis is required prior to the re-use of recovered refrigerant. It is essential that electrical power is available before the task.

- a) Become familiar with the equipment and its operation.
- b) Isolate system electrically.
- c) Before attempting the procedure ensure that:
 - Mechanical handling equipment is available, if required, for handling refrigerant cylinders;
 - All personal protective equipment is available and being used correctly;
 - The recovery process is supervised at all times by a competent person;
 - Recovery equipment and cylinders conform to the appropriate standards.
- d) Pump down refrigerant system, if possible.
- e) If a vacuum is not possible, make a manifold so that refrigerant can be removed from various parts of the system.
- f) Make sure that cylinder is situated on the scales before recovery.
- g) Start the recovery machine and operate in accordance with manufacturer's instructions.
- h) Do not overfill cylinders. (No more than 80 % volume liquid charge).

WARNING

- i) Do not exceed the maximum working pressure of the cylinder, even temporarily.
- j) When the cylinders have been filled correctly and the process completed, make sure that the cylinders and the equipment are removed from site promptly and all isolation valves on the equipment are closed off.
- k) Recovered refrigerant shall not be charged into another refrigeration system unless it has been cleaned and checked.

15. **Labelling**

Equipment shall be labelled stating that it has been de-commissioned and empty of refrigerant. The label shall be dated and signed.

For appliances containing FLAMMABLE REFRIGERANTS, ensure that there are labels on the equipment stating the equipment contains FLAMMABLE REFRIGERANTS.

16. **Recovery**

- When removing refrigerant from a system, either for servicing or decommissioning, it is recommended that all refrigerant is removed safely.
- When transferring refrigerant into cylinders, ensure that only appropriate refrigerant recovery cylinders are employed.
- Ensure that the correct number of cylinders for holding the total system charge is available.
- All cylinders to be used are designated for the recovered refrigerant and labelled for that refrigerant (i.e. special cylinders for the recovery of refrigerant).
- Cylinders shall be complete with pressure relief valve and associated shut-off valves in good working order.
- Empty recovery cylinders are evacuated and, if possible, cooled before recovery.

17. **Competence of service personnel**

Information and training

The training should include the substance of the following:

Information about the explosion potential of flammable refrigerants to show that flammables may be dangerous when handled without care.

Information about potential ignition sources, especially those that are not obvious, such as lighters, light switches, vacuum cleaners, electric heaters.

Information about the concept of sealed components and sealed enclosures according to UL 60335.

Information about the correct working procedures:

a) Commissioning

- Ensure that the floor area is sufficient for the refrigerant charge or that the ventilation duct is assembled in a correct manner.
- Connect the pipes and carry out a leak test before charging with refrigerant.
- Check safety equipment before putting into service.

b) Maintenance

- Portable equipment shall be repaired outside or in a workshop specially equipped for servicing units with flammable refrigerants.
- Ensure sufficient ventilation at the repair place.
- Be aware that malfunction of the equipment may be caused by refrigerant loss and a refrigerant leak is possible.
- Discharge capacitors in a way that won't cause any spark. The standard procedure to short circuit the capacitor terminals usually creates sparks.
- Reassemble sealed enclosures accurately. If seals are worn, replace them.
- Check safety equipment before putting into service.

c) Repair

- Portable equipment shall be repaired outside or in a workshop specially equipped for servicing units with flammable refrigerants.
- Ensure sufficient ventilation at the repair place.
- Be aware that of the equipment may be caused by refrigerant loss and a refrigerant leak is possible.
- Discharge capacitors in a way that won't cause any spark.
- When brazing is required the following procedures shall be carried out in the right order.
 - Remove the refrigerant.

WARNING

- Evacuate the refrigerant circuit.
 - Purge the refrigerant circuit with nitrogen for 5 min.
 - Evacuate again
 - Remove parts to be replaced by cutting, not by flame.
 - Purge the braze point with nitrogen during the brazing procedure.
 - Carry out a leak test before charging with refrigerant.
 - Reassemble sealed enclosures accurately. If seals are worn, replace them.
 - Check safety equipment before putting into service.
- d) Decommissioning
- If the safety is affected when the equipment is put out of service, the refrigerant charge shall be removed before decommissioning.
 - Ensure sufficient ventilation at the equipment location.
 - Be aware that malfunction of the equipment may be caused by refrigerant loss and a leak is possible.
 - Do not discharge capacitors. Remove power from the unit and check that the LEDs on all PCBs are out before working on the unit.
 - Remove the If the recovery is not required by national regulations, drain the refrigerant to the outside. Take care that the drained refrigerant will not cause any danger. In doubt, one person should guard the outlet. Take special care that drained refrigerant will not float back into the building.
- e) Disposal
- Ensure sufficient ventilation at the working place.
 - Remove the refrigerant. If the recovery is not required by national regulations, drain the refrigerant to the outside. Take care that the drained refrigerant will not cause any danger. In doubt, one person should guard the outlet. Take special care that drained refrigerant will not float back into the building.
 - Evacuate the refrigerant circuit
 - Purge the refrigerant circuit with nitrogen for 5 min.
 - Evacuate again.
 - Cut out the compressor and drain the oil.
-
- The pipe-work shall be complied with national gas regulations.
 - The maximum refrigerant charge amount is X kg (X see below).
 - Where addition of charge is required to complete installation, according to the content in "Refrigerant piping" . After charged, finish the label (in accessory bag) and paste it near the nameplate.
 - When moving or relocating the air conditioner, consult experienced service technicians for disconnection and reinstallation of the unit.
 - Do not place any other electrical products or household belongings under indoor unit or outdoor unit.
 - Condensation dripping from the unit might get them wet, and may cause damage or malfunction of your property.
 - Do not use means to accelerate the defrosting process or to clean, other than those recommended by the manufacturer.
 - The appliance shall be stored in a room without continuously operating ignition sources (for example: open flames, an operating gas appliance or an operating electric heater).
 - Do not pierce or burn.
 - Be aware that refrigerants may not contain an odour.
 - To keep ventilation openings clear of obstruction.
 - The appliance shall be stored in a well-ventilated area where the room size corresponds to the room area as specified for operation.
 - The appliance shall be stored in a room without continuously operating open flames (for example an operating as appliance) and ignition sources (for example an operating electric heater).
 - Any person who is involved with working on or breaking into a refrigerant circuit should hold a current valid certificate from an industry-accredited assessment authority, which authorises their competence to handle refrigerants safely in accordance with an industry recognised assessment specification.
 - Servicing shall only be performed as recommended by the equipment manufacturer.
 - Maintenance and repair requiring the assistance of other skilled personnel shall be carried out under the supervision of the person competent in the use of flammable refrigerants.
 - The appliance shall be installed and stored so as to prevent mechanical damage from occurring.
 - Mechanical connectors used indoors shall comply with ISO 14903. When mechanical connectors are reused indoors, sealing parts shall be renewed. When flared joints are reused indoors, the flare part shall be re-fabricated.
 - The installation of pipe-work shall be kept to a minimum.
 - Mechanical connections shall be accessible for maintenance purposes.

⚠ WARNING

- That pipe-work including piping material, pipe routing, and installation shall include protection from physical damage in operation and service, and be in compliance with national and local codes and standards, such as ASHRAE 15, ASHRAE 15.2, IAPMO Uniform Mechanical Code, ICC International Mechanical Code, or CSA B52. All field joints shall be accessible for inspection prior to being covered or enclosed;
- That after completion of field piping for split systems, the field pipework shall be pressure tested with an inert gas and then vacuum tested prior to refrigerant charging, according to the following requirements;

The minimum test pressure for the low side: 415psig(2.86MPa)

The minimum test pressure for the high side: 600psig(4.14MPa)

- Field-made refrigerant joints indoors shall be tightness tested. The test method shall have a sensitivity of 0.18 oz per year of refrigerant or better under a pressure of at least 0,25 times the maximum allowable pressure. No leak shall be detected. The joints must be welded or brazed.





Label in accessory bag

Contains Flammable Refrigerants	
Contient des réfrigérants inflammables	
Refrigerant:	R454B
Fluide frigorigène:	
Additional Charge:	<input type="text"/> OZ
Charge supplémentaire:	
Total Charge (Installer Reference):	<input type="text"/> OZ
Charge totale (Référence du Programme d'installation):	

Max. Refrigerant Charge Amount X[oz.(g)]

Capacity (Btu/h)	24K	36K	48K
Max. Refrigerant charge [oz.(g)]	126.53(3587)	165.22(4684)	256.2(7263)

Explanation of symbols displayed on the indoor unit or outdoor unit.

	WARNING	This symbol shows that this appliance uses a flammable refrigerant. If the refrigerant is leaked and exposed to an external ignition source, there is a risk of fire.
	CAUTION	This symbol shows that the operation manual should be read carefully.
	CAUTION	This symbol shows that a service personnel should be handling this equipment with reference to the installation manual.
	CAUTION	This symbol shows that information is available such as the operating manual or installation manual.

Electrical Wiring Diagram

Outdoor unit connected to a Duct /Cassette / Matched AHU indoor unit

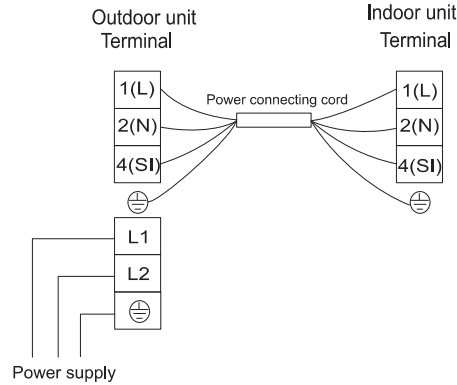

Outdoor unit connected to a Wall-mounted indoor unit

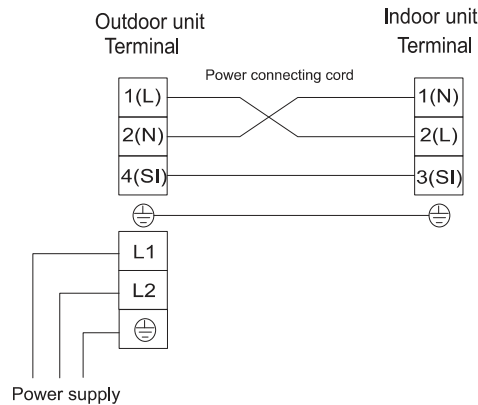

Outdoor unit connected to a 3rd party AHU indoor unit

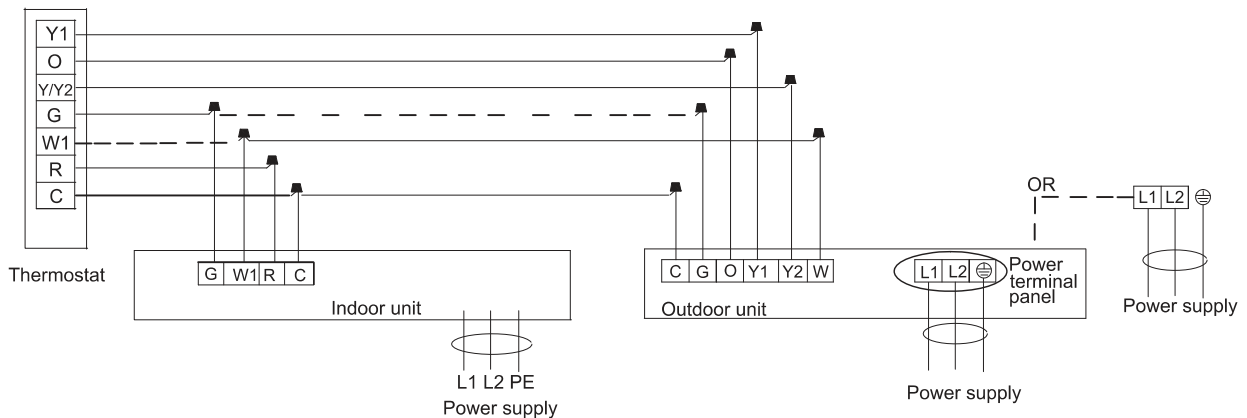

EXPLANATION OF TERMINALS

Y1: COOLING/ HEATING (LOW RANGE)
 Y2: COOLING/ HEATING (HIGH RANGE)
 O - REVERSING VALVE SIGNAL (ENERGIZE TO COOL)
 C- COMMON
 R-24v AC
 G- INDOOR FAN SIGNAL
 W - DEFROST SIGNAL
 W1 - ELECTRIC AUXILIARY HEAT SIGNAL

NOTE 1: INDOOR UNIT SHOULD BE CONNECTED ACCORDING TO THE WIRING DIAGRAM OF THE INDOOR UNIT.

NOTE 2: WHEN AUXILIARY HEATING IS SELECTED, THE THERMOSTAT NEEDS TO BE CONNECTED TO TERMINALS W1 AND W2 OF THE INDOOR UNIT, AS SHOWN BY THE DOTTED LINE.

NOTE 3: WIRING FROM G TERMINAL ON THERMOSTAT TO G TERMINAL ON OUTDOOR UNIT IS OPTIONAL. THIS INDOOR FAN SIGNAL PROVIDES FEEDBACK TO THE OUTDOOR UNIT FOR THE COOL/HEAT PURGE CYCLE. THIS WIRE MAY BE DISCONNECTED, AND THE UNIT WILL STILL RUN, BUT WITH LESS EFFICIENCY.

Note:

- 1) When connecting AHU indoor units, the indoor unit wiring should be operated according to the indoor unit wiring diagram.
- 2) Dashed line is only hooked up when aux heat kit is installed.

Installation Instructions

Transportation and Handling before Installation

Transport the product as close to the installation location as practical before unpacking.

- Handling Method

When handling the unit, ensure a balance of the unit, check safety and lift it up smoothly.

- (1) Do not remove any packing materials.
- (2) Hang the unit under packing condition with two ropes, as shown in Fig. below.

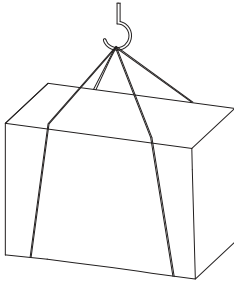

- Handling

If have no package to move, please protect with cloth or paper.

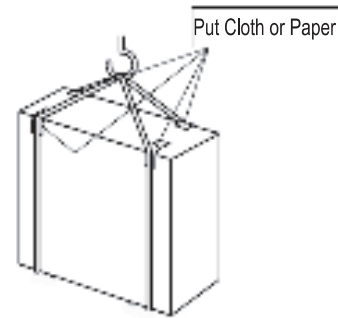

Installation Locations Selection

Selection of installation location During installation, it is essential to fully consider the space required for maintenance and to avoid placing any obstacles at the ventilation outlets that could block air circulation. The following installation locations should be avoided:

- Places with flammable and explosive hazards, such as coal dust, metal dust, cotton lint, petroleum, natural gas, etc.. and places like mines, gas stations, or production workshops in industries such as coal dust, garment manufacturing, woodworking, cement, and cotton quilt factories;
- Special places with strong heat sources, steam, constant temperature, and humidity, such as fruit preservation warehouses, bath centers, etc.;
- Environments with corrosive or sulfurous, volatile gases, such as sulfur, acid, salt, papermaking sites, sulfur springs, chemical plants, etc.;
- Places with high frequency electromagnetic interference facilities, such as welding machines, frequency converters, radio transmission equipment, medical equipment, etc.;
- Places filled with mineral oil fumes or spray or steam, for example, the kitchen.

If the oil is attached to the heat exchanger, it will degrade the performance of the indoor unit and may damage its plastic parts.

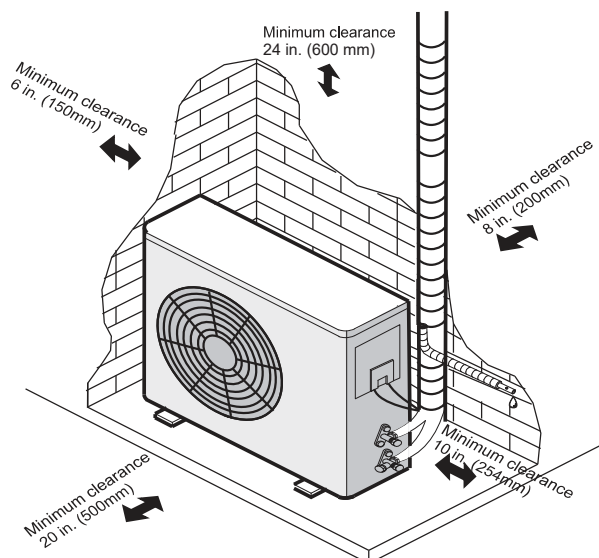

Installation Instructions

Drainage Elbow and Drain Hose Installation

Install Drainage Elbow and Drain Hose

- The condensate water may drain from the outdoor unit when the unit operates in heating mode. In order to avoid disturbing neighbors and to protect the environment, it is necessary to install a drainage elbow and a condensate drain hose to drain out the condensate water.
- Perform drainage work before the indoor unit and outdoor unit are connected. Otherwise, it will be difficult to install drainage elbow after the machine becomes immovable.)
- Connect the drain hose [field-supplied, inside diameter: 5/8 in. (15mm)] as shown in the figure for drainage.

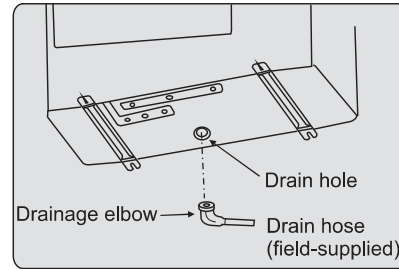

Note:

- Do not use the drainage elbow in the cold region. Drain may freeze.

Outdoor Unit Installation

- (1) Use the washers to fasten the machine at the foundation bolts.
- (2) When fastening the outdoor unit with the foundation bolts, the fasten holes position as the Fig.1.
- (3) Fasten the outdoor unit as shown in Fig.2.
- (4) Make sure to fasten the outdoor unit tight and level to prevent noise from occurring.
- (5) Do not drain off water to the public places to hazardous slips/falls.
- (6) The strong base (made of concrete, etc.) should be made. The appliance should be placed not less than 4in. (10cm) high to avoid being wet or corroded. Otherwise, it may cause damage to the appliance or reduce its life time. (Fig.3)

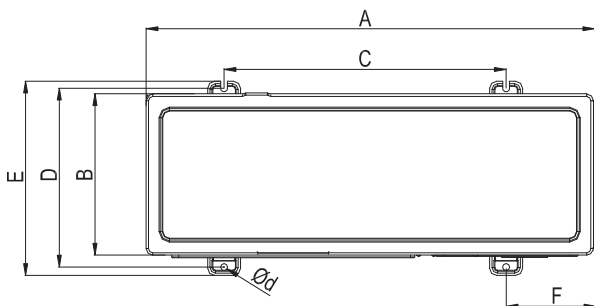
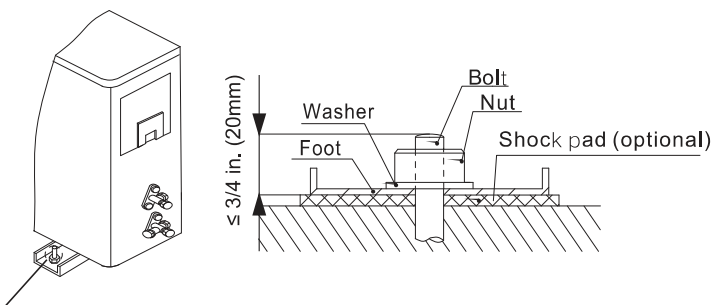

Fig.1

[unit: in. (mm)]

Capacity (Btu/h)	A	B	C	D	E	F	d
24K	35-3/8 (900)	13-3/8 (340)	23-7/8 (608)	14-1/2 (368)	15-5/8 (398)	5-3/4 (146)	3/8*3/4 (10*20)
36K	43-1/4 (1100)	17-3/4 (450)	25-1/4 (640)	19-1/8 (485)	20-1/4 (515)	9-1/4 (235)	1/2*3/4 (12*20)
48K	41-3/4 (1060)	13 (330)	23 (585)	14-1/2 (367)	15-1/2 (395)	7-5/8 (195)	1/2*3/4 (12*20)



The anchor bolts should be protruded $\leq 3/4$ in. (20mm) (Refer to figure), otherwise, it is not conducive to removing the service plate.

Fig.2

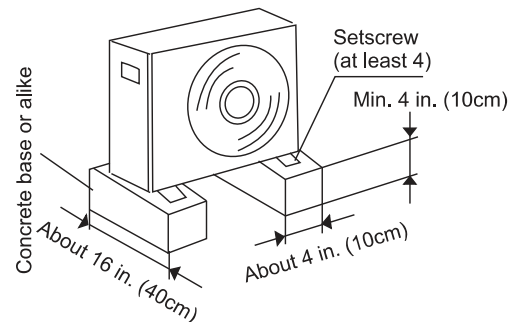

Fig.3

Refrigerant Piping

1. Piping Diameter

Capacity(Btu/h)	Outer Diameter of Pipe	
	Gas [in.(mm)]	Liquid [in.(mm)]
24K/36K	Φ 5/8 (15.88)	Φ 3/8 (9.52)
48K	Φ 3/4 (19.05)	Φ 3/8 (9.52)

2. Pipe length

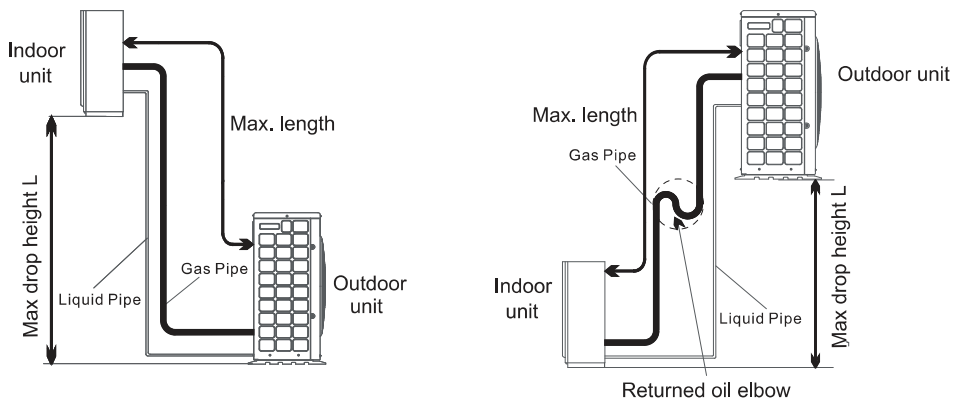

Capacity (Btu/h)	Min. Pipe length (L)	Max. Pipe length (L)	Max. Height difference (H)
24K/36K	10ft. (3m)	165ft. (50m)	100ft. (30m)
48K	10ft. (3m)	250ft. (75m)	100ft. (30m)

CAUTION

It is better with the shorter refrigerant piping length to maintain the capacity. So the connecting pipe should be as short as possible.

When the indoor unit is lower than outdoor unit and the height difference is larger than 32.8 ft.(10m), a returned oil elbow should be installed on the vertical gas pipe for every 20 ft.(6m).

3. Piping Material

- (1) Prepare locally-supplied copper pipes.
- (2) Select clean copper pipes. Make sure there is no dust and moisture inside the pipes. Blow the inside of the pipes with nitrogen, to remove any dust or foreign materials before connecting pipes.
- (3) Piping thickness and material are shown as below.

Diameter [in. (mm)]	ø 1/4 (6.35)	ø 3/8 (9.52)	ø 1/2 (12.70)	ø 5/8 (15.88)	ø 3/4 (19.05)	ø 7/8 (22.22)
Thickness [in. (mm)]	1/32 (0.8)	1/32 (0.8)	1/32 (0.8)	1/32 (1.0)	1/32 (1.0)	1/32 (1.0)
Material	C1220T-O, Type O, TP2M					

CAUTION

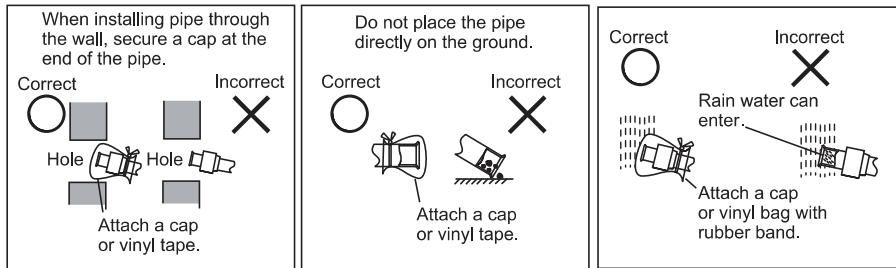

4. Refrigerant piping work

- (1) Pipe cutting
Cut the copper pipe correctly with a pipe cutter.
- (2) Burrs removal
Completely remove all burrs from the cross section of the pipe.
Orient the end of the copper pipe downward to prevent burrs from dropping in the pipe.
- (3) Putting nut on
Remove flare nuts attached to indoor and outdoor units, then put them on the pipe, burrs of which have been removed.
(Not possible to put them on after flaring work).
Flare nut for pipe depends on the diameter of pipe.
- (4) Flaring work
Perform flaring work with a flaring tool as shown below.
- (5) Check
Compare the flared work with the figure below.
If flare is noted to be defective, cut off the flared section and perform flaring work again.

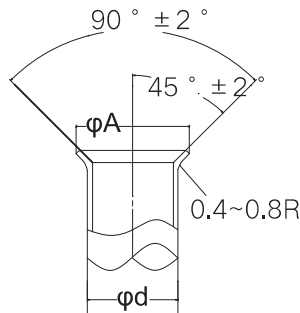

[Unit: in. (mm)]

Diameter ød	A ⁺⁰ _{-1/64} (+0 -0.4)
1/4 (6.35)	11/32 (9.1)
3/8 (9.52)	1/2 (13.2)
1/2 (12.7)	10/16 (16.6)
5/8 (15.88)	3/4 (19.7)
3/4 (19.05)*	15/16 (24.0)

*: Perform the flaring work with type O material.

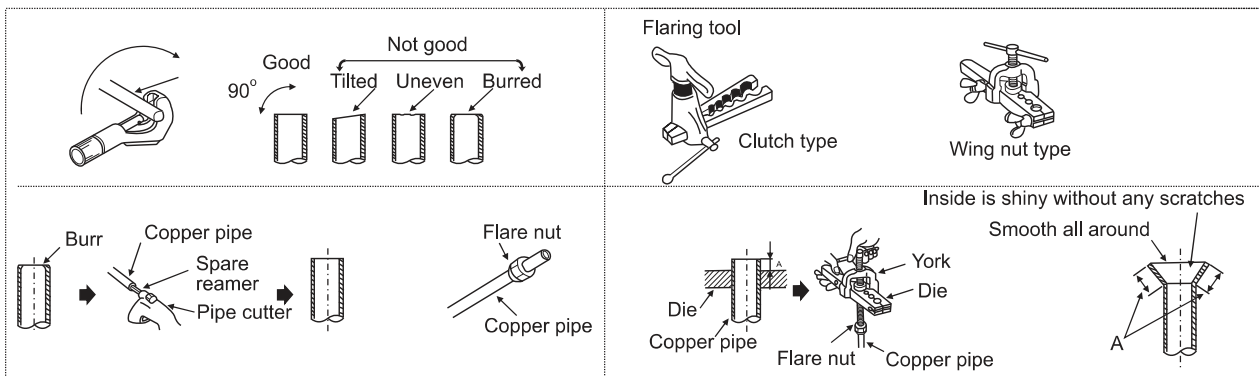

5. Piping connection (when outdoor unit connected to a duct /cassette /wall-mount indoor unit)

- (1) Confirm that the valve is closed.
- (2) Connect the indoor unit and the outdoor unit with field-supplied refrigerant piping. Suspend the refrigerant piping at certain points and prevent the refrigerant piping from touching the weak part of the building such as wall, ceiling, etc. (If touched, abnormal sound may occur due to the vibration of the piping. Pay special attention in case of short piping length.)
- (3) Tighten the flare nut with two spanners (one being a torque wrench) as shown in the right figure.
- (4) Apply the refrigerant oil (field-supplied) thinly at the seat surface of the flare nut and pipe before connecting and tightening.
And when tightening the flare nut, use two spanners.
- (5) Outdoor refrigerant piping should connect with stop valve.

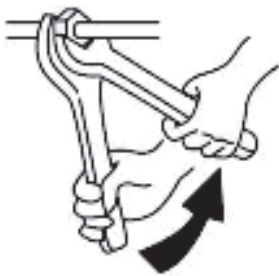

Double Spanner Work

Pipe size [in. (mm)]	Torque [lbf-ft. (N·m)]
ø 1/4 (6.35)	14.8 (20)
ø 3/8 (9.52)	29.5 (40)
ø 1/2 (12.7)	44.3 (60)
ø 5/8 (15.88)	59.0 (80)
ø 3/4 (19.05)	73.8 (100)

Tightening Torque for Flare Nut

▲ CAUTION

Precautions when brazing the refrigerant pipings

When brazing the refrigerant piping, carry out brazing work(CAUTION2) after substituting nitrogen for air [flow nitrogen into the piping and substitute nitrogen for air(CAUTION1)(see the drawing below)].

1. The proper pressure for having nitrogen flow through the piping is approximately 2.9 psig(0.02 MPa), a pressure that makes one feel like breeze and be obtained through a pressure reducing valve.
2. Do not use flux when brazing refrigerant piping. Use phosphor copper brazing filler metal (BCuP-2; JIS Z 3264/ B-Cu93P-710/795: ISO 3677) that does not require flux. (If chlorinated flux is used, the piping will be corroded and, in addition if fluorine is contained, the refrigerant oil will be deteriorated and the refrigerant circuit will be affected badly.)

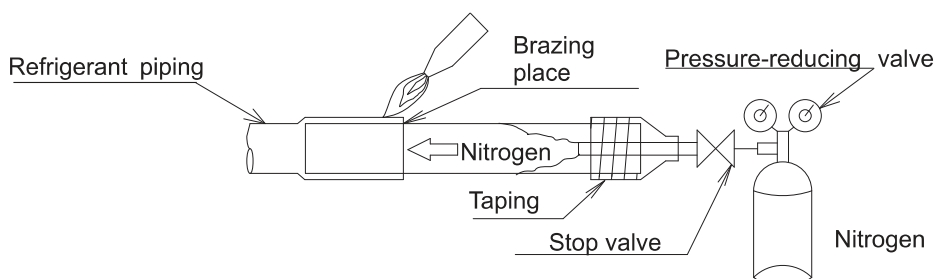

▲ CAUTION

Do not use anti-oxidants when brazing the piping joints(Residue can clog pipes and break equipment).
Do not reuse joint which have been used once already.

6. Piping connection (when outdoor unit connected to an AHU indoor unit)

- (1) R454B refrigerant is flammable, confirm that the valves are closed.
- (2) Connect the indoor unit and the outdoor unit with field-supplied refrigerant pipes. The refrigerant piping should be brazed with a phosphorous-copper alloy material such as Silfos-15 or equivalent.

Precautions and steps during brazing:

- a. Remove the adapter fittings (liquid piping/gas piping) from the accessory kit. Connect the flare nut ends to the corresponding service valves(liquid valve/ gas valve), then detach the copper sealing caps by performing nitrogen-purged brazing on the opposite ends.
- b. Braze the liquid piping and gas piping to the adapter fittings.

Precautions should be taken to prevent heat damage to service valve by wrapping a wet cloth around it.

Also, a Heat shield can be set to protect all painted surfaces, insulation, during brazing.

- c. After brazing cool joint with wet rag.

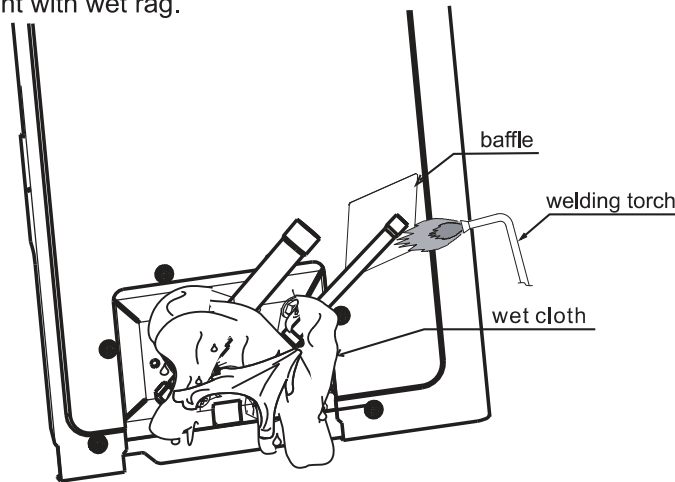

- (3) After finishing connecting the refrigerant pipes, insulate with proper insulation.

- For outside unit, insulate both pipes.
- Cover piping joints with pipe cover.
- Using piping tape, apply taping starting from the entry of outdoor unit.
 - Fix the end of piping tape with adhesive tape.
 - When piping has to be arranged through above ceiling, closet or area where temperature and humidity are high, install additional sold insulation for prevention of condensation.

7. Line pressure tightness test

-Use Nitrogen only. Do not used compressed air.

Connect the gauge manifold using charging hoses with a nitrogen cylinder to the check joints of the liquid line and the gas line stop valves.

Perform the line pressure tightness test.

Don't open the gas line stop valves.

Apply nitrogen gas pressure of 550 psig (3.79 MPa).

Check for any gas leakage at the flare nut connections, or brazed parts by gas leak detector or foaming agent.

Gas pressure doesn't decrease is OK.

After the air tight test, release nitrogen gas.

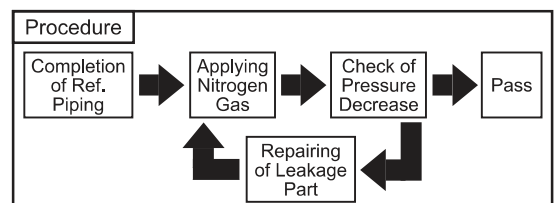

Air tight procedure

8. Vacuum Pumping

- (1) Remove the service port cap of the stop valve on the gas pipe side of the outdoor unit.
- (2) Connect the manifold gauge and vacuum pump to the service port of the stop valve on the gas pipe side of the outdoor unit.
- (3) Run the vacuum pump. (Work for more than 15 minutes.)
- (4) Check the vacuum with the gauge manifold valve, then close the gauge manifold valve and stop the vacuum pump.
- (5) Leave it as is for one or two minutes. Make sure that the pointer of the manifold gauge remains in the same position. Confirm that the pressure gauge shows -14.7psig (-0.101MPa or -760mmHg).
- (6) Remove the manifold gauge quickly from the service port of the stop valve.
- (7) After refrigerant pipes are connected and evacuated, fully open all stop valves on both sides of gas pipe and liquid pipe.
- (8) Open adjusted valve to add refrigerant (the refrigerant is liquid).
- (9) Tighten the cap to the service port.
- (10) Retighten the cap.
- (11) Leak test foam with halogen leak detector to check the flare nut and brazing for leaks. Use foam that does not generate ammonia (NH₃) in the reaction.

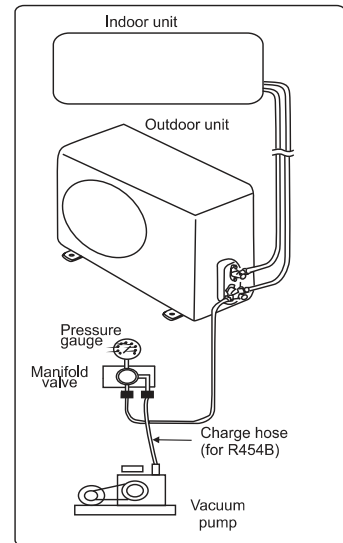

▲ CAUTION

This system is only applicable to R454B refrigerant, and the pressure gauge and charging hose must be special for R454B. If the pressure gauge pointer does not move to -14.5psig [-0.1 MPa (-756 mmHg)], please make sure to check for leaks at the valve connection between the indoor and outdoor units, and then proceed to the next step after repairing the leak.

Methods for opening and closing the stop valve

- The following figure shows the names of each component required to process the stop valve (Fig.1). The stop valve is closed before installation.
- Opening and closing the stop valve: Prepare hexagon wrenches.
 - (1) Open the stop valve: Insert the hexagon wrench into the valve stem, rotate the valve stem counterclockwise, and stop rotating when the valve stem can no longer rotate. At this point, the valve has already opened.
 - (2) Close the stop valve: Insert the hexagon wrench into the valve stem, rotate the valve stem clockwise, and stop rotating when the valve stem can no longer rotate. At this point, the valve has already closed.

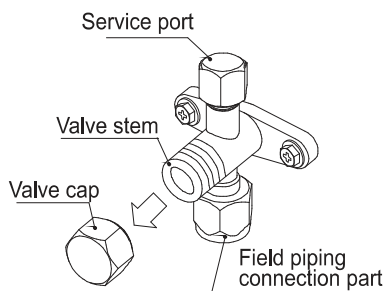

Fig.1

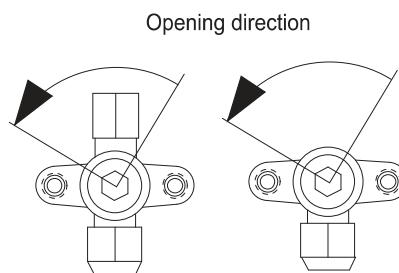

Fig.2 Liquid pipe

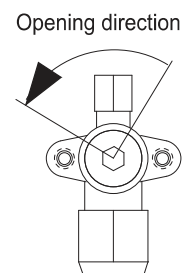

Fig.3 Gas pipe

9. Additional Refrigerant Charge

This operation must be completed with an electronic scale for weighing. The refrigerant is charged to the air conditioning unit through the service port of the stop valve at low-pressure side.

- (1) Connect the manifold pressure gauge to the refrigerant cylinder first, remove the air from the charging hose, and then connect it to the charging port of the stop valve at the low-pressure side of the outdoor unit.
- (2) Start the air conditioning unit for refrigeration.
- (3) Open the refrigerant cylinder and pressure gauge valve.
- (4) After the required amount of refrigeration is charged into the unit, quickly close the valves at the low-pressure side and of the refrigerant cylinder.
- (5) Disconnect the charging hose from the service port of the stop valve and tighten the service port cap.

CAUTION

- Excessive or insufficient refrigerant is the main cause of unit faults. The outdoor unit is pre-charged with refrigerant when it leaves the factory, please charge the correct amount of refrigerant according to the instructions.
- After charging, please close the valve and record the refrigerant charging amount.

Amount of refrigerant additionally charged

If the pipe length is less than 25ft.(7.5 m), *there is no need for additional charging after triple evacuation. When the length of the pipe is greater than 25ft.(7.5 m), calculate according to the following table.

Capacity (Btu/h)	Amount of refrigerant pre-charged before leaving the factory/W ₀ [oz(g)]	Amount of refrigerant additionally charged X [oz(g)]	
		pipe length(L)≤ 25ft.(7.5m)	pipe length(L)≥ 25ft.(7.5m)
24K*	74.1(2100)	0	$X=0.38(\text{oz/ft}) [35(\text{g/m})] \times [L-25\text{ft.}(7.5\text{m})]$
36K	112.8(3200)	0	$X=0.38(\text{oz/ft}) [35(\text{g/m})] \times [L-25\text{ft.}(7.5\text{m})]$
48K	172.8(4900)	0	$X=0.38(\text{oz/ft}) [35(\text{g/m})] \times [L-25\text{ft.}(7.5\text{m})]$

*: Regardless of pipe length, when an AHU is connected to a 24k outdoor unit, an additional refrigerant charge of 7.05 oz (200g) is required. This is due to the increased refrigerant requirement of the AHU coil, and is required for proper operation.

Wiring



WARNING

- Turn OFF the main power switch to the indoor unit and the outdoor unit and wait for more than 3 minutes before electrical wiring work or a periodical check is performed.
- Check to ensure that the indoor fan and the outdoor fan have stopped before electrical wiring work or a periodical check is performed.
- Protect the wires, electrical parts, etc. from rats or other small animals. If not protected, rats may gnaw at unprotected parts and at the worst, a fire will occur.
- Avoid the wirings from touching the refrigerant pipes, plate edges and electrical parts inside the unit. If not do, the wires will be damaged and at the worst, a fire will occur.
- An ELB type circuit breaker may be required for this unit depending on local and national electrical codes. An ELB type breaker is recommended in moist and/ or humid locations.
- This unit uses an inverter, which means that it must be used an earth leak detector capable handling harmonics in order to prevent malfunctioning of the earth leak detector itself.
- Do not use intermediate connection wires, stranded wires (For Main Power Supply), extension cables or control line connection, because the use of these wires may cause high temperature, electric shock or fire.
- The tightening torque of each screw shall be as follows.
 - M4: 0.7 to 1.0 lbf-ft. (1.0 to 1.3 N·m)
 - M5: 1.5 to 1.8 lbf-ft. (2.0 to 2.5 N·m)
 - M6: 3.0 to 3.7 lbf-ft. (4.0 to 5.0 N·m)
 - M8: 6.6 to 8.1 lbf-ft. (9.0 to 11.0 N·m)
 - M10: 13.3 to 217 lbf-ft. (18.0 to 23.0 N·m)Keep the above tightening torque when wiring work.



CAUTION

- With tape material along the wire wrapped, sealed wiring holes, prevent the condensed water and insects.
- Tightly secure the power source wiring using the cord clamp inside the unit.
Note: Fix the rubber bushes with adhesive when conduit tubes to the outdoor unit are not used.

General check

- (1) Make sure that the field-selected electrical components (main power switches, circuit breakers, wires, conduit connectors and wire terminals) have been properly selected according to the electrical data.
Make sure that the components comply with National Electrical Code (NEC).
- (2) Check to ensure that the voltage of power supply is within +10% of nominal voltage and earth phase is contained in the power supply wires. If not, electrical parts will be damaged.
- (3) Check to ensure that the capacity of power supply is enough.
If not, the compressor will be not able to operate cause of voltage drop abnormally at starting.
- (4) Check to ensure that the earth wire is connected.
- (5) Install a main switch, multi-pole main switch with a space of 0.14 in. (3.5mm) or more, single phase main switch with a space of 0.12 in. (3.0mm) or more between each phase.
- (6) Check to ensure that the electrical resistance is more than 2 MΩ, by measuring the resistance between ground and the terminal of the electrical parts. If not, do not operate the system until the electrical leakage is found and repaired.

Electrical Data

Capacity (Btu/h)	Power Supply	ELB		MCA (A)	Transmitting Cable Size	Circuit Breaker (A)
		Rated Current (A)	Nominal Sensitive Current (mA)			
24K	208/230V ~/60Hz	30	30	22	4x14AWG stranded THHN	30
36K	208/230V ~/60Hz	50	30	30	4x14AWG stranded THHN	50
48K	208/230V ~/60Hz	60	30	50	4x14AWG stranded THHN	60

Max. Running Current (A): REFER TO NAMEPLATE

Note:

- (1) Follow local codes and regulations when select field wires, and all the above are the minimum wire size.
- (2) 18AWG. color-coded low voltage wire may be used for lengths less than 100ft.(30m). For wire lengths than 100ft.(30m), 16AWG. wire may be used. When transmitting cable length is longer than 262ft. (80m), a larger wire size should be selected.
- (3) Install main switch and ELB for each system separately. Select the high response type ELB that is acted within 0.1second. Recommended capacity to see outdoor machine switch capacity.
- (4) For non-matched AHU configuration, 6 wire thermostat wire is required without aux. heat, and 8 wire should be used with aux. heat.

<Notice - When connecting the transmitting cable to indoor unit.>

1. When connecting the terminal block, use stranded wire. Make sure to use the round crimp-style terminal for connection to the power supply terminal block. Place the round crimp-style terminals on the wires up to the covered part and secure in place.
2. NOTICE- When connecting main power supply to the unit.
3. When connecting the terminal block using a single core wire, be sure to perform curing.

The diagram illustrates two connection methods. The top part shows a 'Round crimp-style terminal' being attached to a 'Stranded wire' up to a 'covered part'. The bottom part shows a 'Single core wire' being inserted into a 'Terminal' block.

Dip Switch Setting

When connecting the 24k Condenser to an 18k air handler, the S5-1 dip switch must be placed in the ON position.

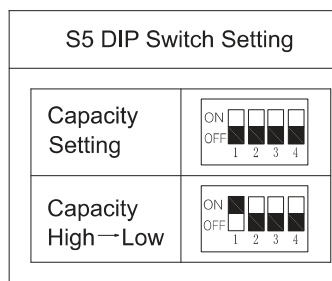

Checker Box (Only for 36K)

For 36K, during installation, please connect the Checker box supplied in the accessories to the electrical box as shown in the figure below.

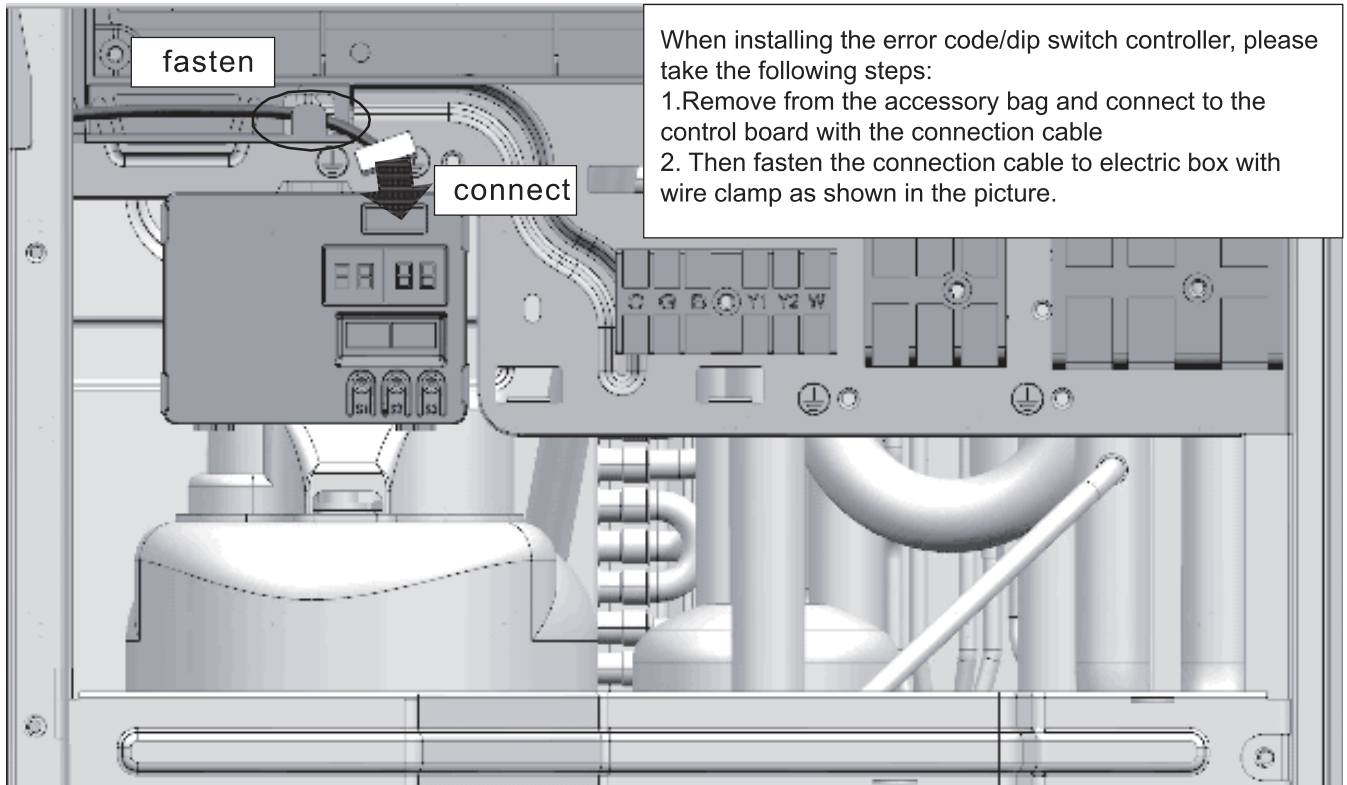

Test Run

1. Preparation before test run and precautions

Please turn off all power supplies and confirm with a testing instrument whether all power supplies have been turned off.

Before running, please proceed the following steps to inspect the installation status:

- (1) Structural damage inspection
Confirm whether there is no damage on the surface and interior of the equipment.
- (2) Outdoor fan inspection
Confirm whether the impeller of the fan is located in the middle of the air outlet. Do not touch the air outlet.
- (3) Fastening screw inspection
Check whether the screw parts become loose due to vibration during transportation, In addition, confirm whether the screws are tightened during installation.
Especially, be sure to inspect the screws of electrical wiring more carefully.
- (4) Refrigerant leakage inspection
Vibration during transportation may cause loosening of the fastening (flaring part) position of the pipe. Check for refrigerant leakage.
Be sure to carry out this inspection carefully.
- (5) Dial switch setting inspection
Confirm whether the dial switch is in the set position at the time of delivery (see: Dial setting of the outdoor unit).
- (6) Insulation resistance inspection
Measure whether the resistance between the electrical component terminals and the ground reaches 2 MΩ or above with a 500 V megameter. When the resistance is below 2 MΩ, it indicates poor insulation at the electrical connection position, and the equipment cannot be operated at this time.
In addition, do not apply power to the communication line terminal block (otherwise it will cause damage to the printed circuit board).
- (7) Full opening of stop valve
Before conducting a test run, please check whether the stop valve of the outdoor unit is fully open.
- (8) Power supply phase inspection
Do not operate when the phase sequence is incorrect or missing.
- (9) Power-on of crankcase heating belt
After completing the inspection of item (1) to (8), connect the outdoor unit power supply. After powering on the crankcase heating belt, the compressor can be preheated. If outdoor ambient temperature is below 32 degrees F, the compressor is not preheated and started directly, the compressor will fail. The unit can only be started after 6 hours of power-on.
- (10) Confirmation of indoor and outdoor ambient temperature
The indoor ambient temperature during refrigeration operation shall not be lower than 80.6°F(27°C), and the outdoor ambient temperature during heating operation shall not exceed 66.2°F(19°C).



WARNING

The machine can be started only after all checkpoints are checked without problems.

- (1) Check to ensure that the ground resistance of the wiring terminals exceeds 2 MΩ, Otherwise, find out and repair the leaking part before starting the system.
- (2) Check and ensure that all stop valves of the outdoor unit are turned on before starting the system.
- (3) It is recommended to power on for at least 6 hours to ensure sufficient lubrication of the compressor and extend its service life.

2. Identification of test run functions

Turn on the thermostat/wall controller and perform a test run.

Test whether the function and display of the air conditioning unit are normal and whether the temperature control is in good state during the test run.

When the system is operating, the following conditions shall be noticed.

- (1) Do not touch any parts at the exhaust end to avoid scald. This is because the temperature of the compressor and pipes at the exhaust end is heated to above 194°F(90°C).
- (2) After the test run is completed, turn off the power. Do not touch any electrical components within 10 mins after switching off the main power supply.
After completing the above operations, the installation of the equipment is usually completed. If you still have any questions, please contact our local technical service center for more information.

