

1814E with FilterQuick™

Electric Fryer

Wiring Diagrams

This manual is updated as new information and models are released. Visit our website for the latest manual.



8 1 9 7 3 2 0
Part Number: FRY_D_8197320 08/2022



 **DANGER**

Prior to movement, testing, maintenance and any repair on your Frymaster fryer, disconnect ALL electrical power from the fryer.

1814 with FILTERQUICK™ SERIES ELECTRIC FRYER

Table of Contents

SECTION 1: Wiring Diagrams

1.1 Control Wiring	1-1
1.2 Contactor Box – Delta Configuration	1-2
1.3 Contactor Box – WYE Configuration	1-3

1814E with FILTERQUICK™ SERIES ELECTRIC FRYER

SECTION 1: WIRING DIAGRAMS

1.1 Control Wiring

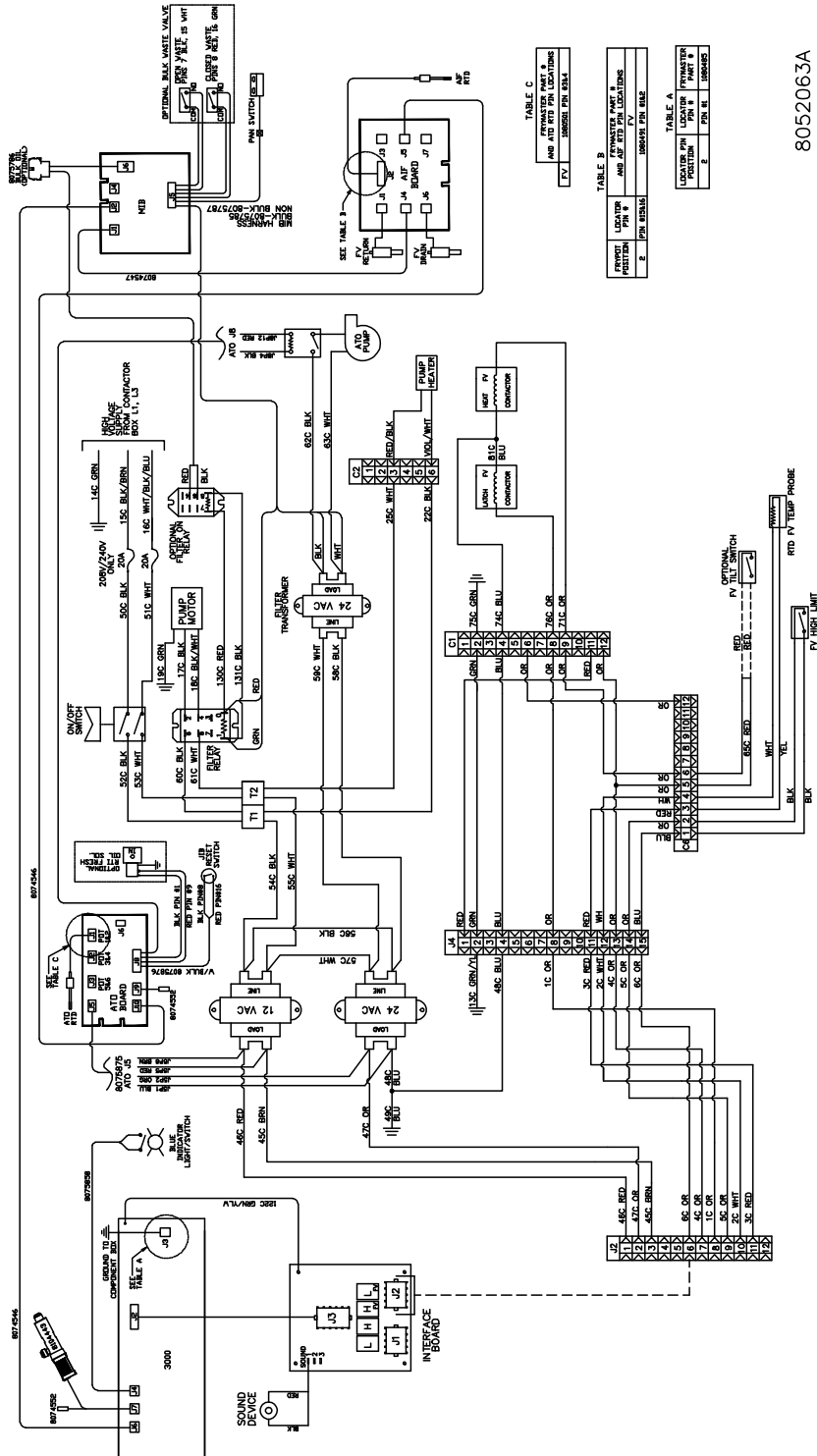

8052063A

1.2 Contactor Box – Delta Configuration

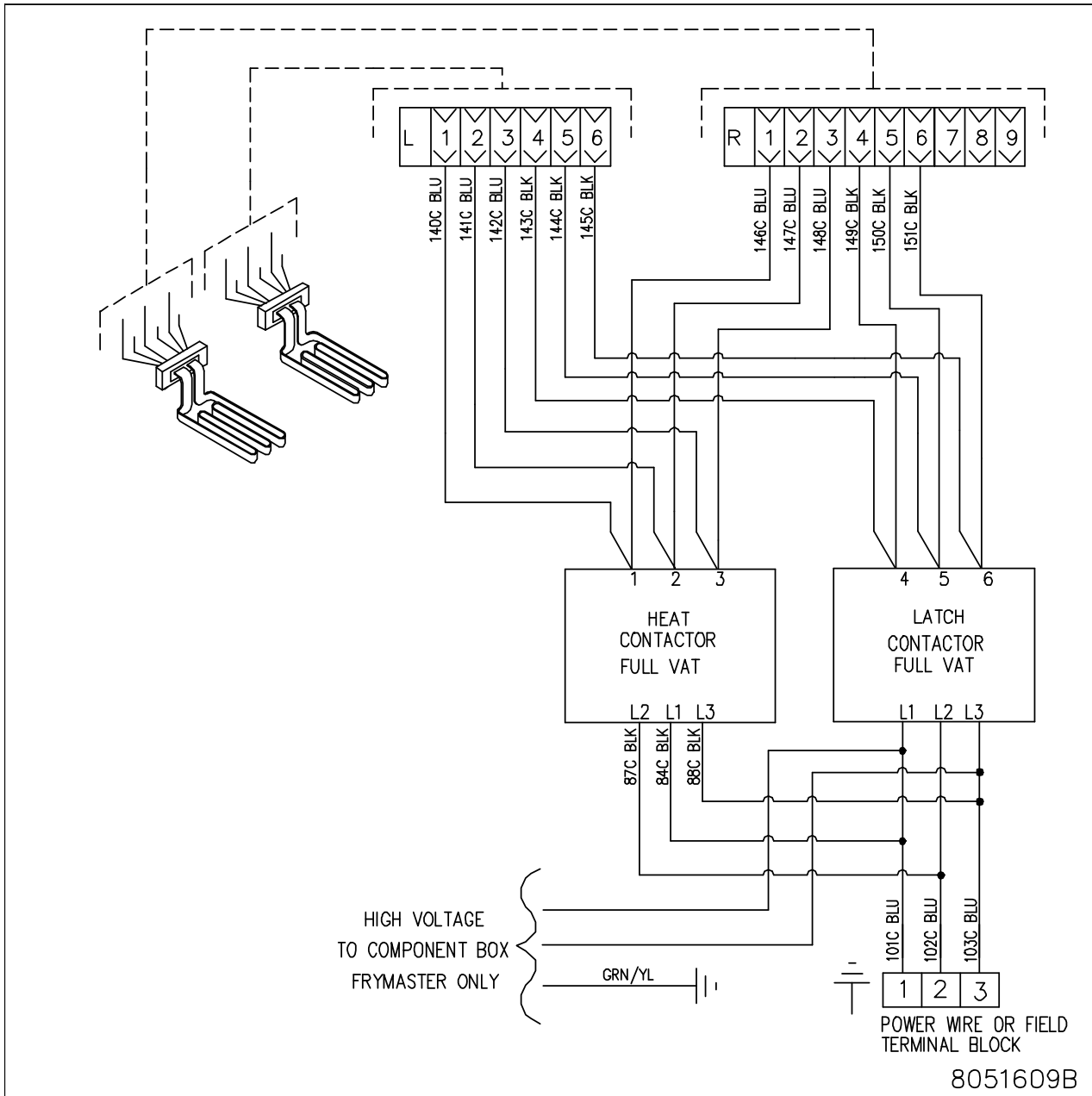

1.3 Contactor Box – WYE Configuration

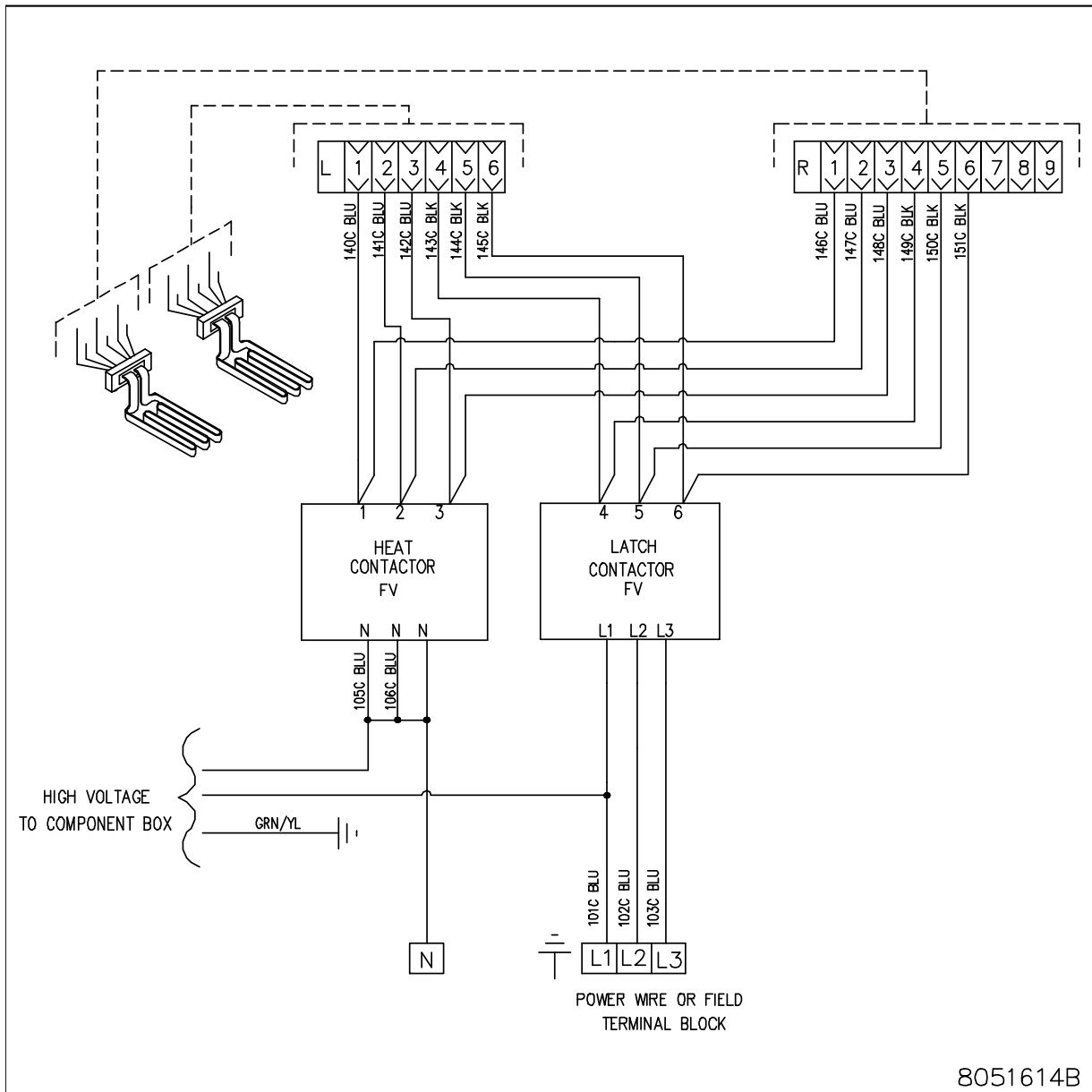

THIS PAGE INTENTIONALLY LEFT BLANK



Welbilt offers fully-integrated kitchen systems and our products are backed by KitchenCare[®] aftermarket parts and service. Welbilt's portfolio of award-winning brands includes Cleveland[™], Convothem[®], Crem[®], Delfield[®], Frymaster[®], Garland[®], Kolpak[®], Lincoln[®], Merco[®], Merrychef[®] and Multiplex[®].

Bringing innovation to the table • welbilt.com