

STEP 11

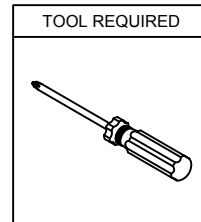

STEP 12

Recommended Maximum Weight

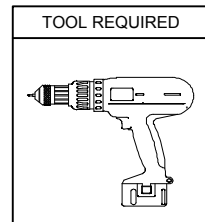
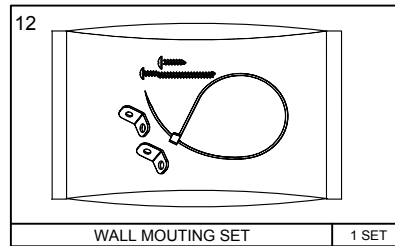
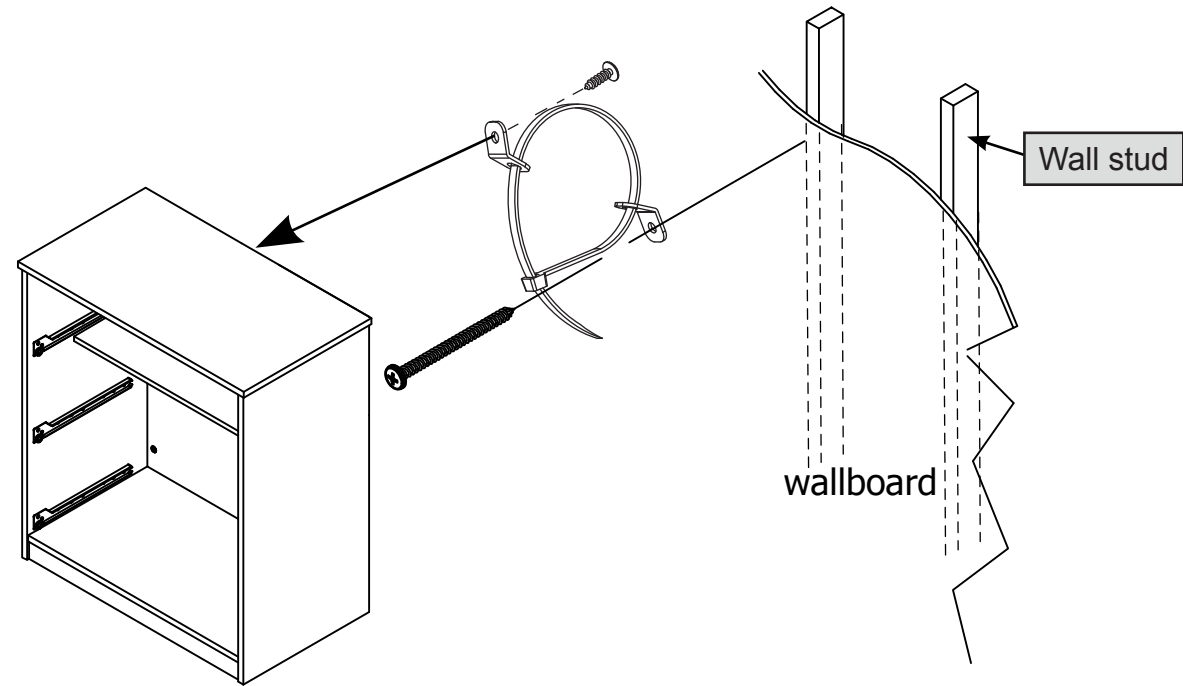
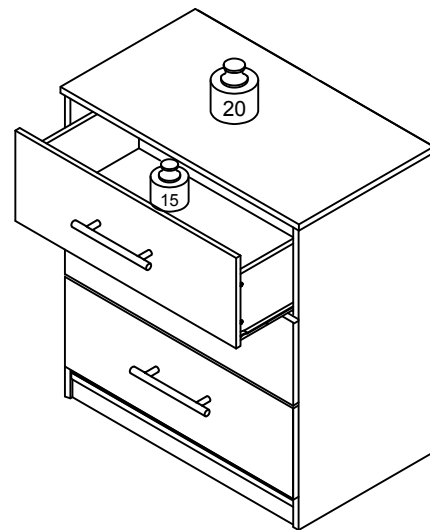
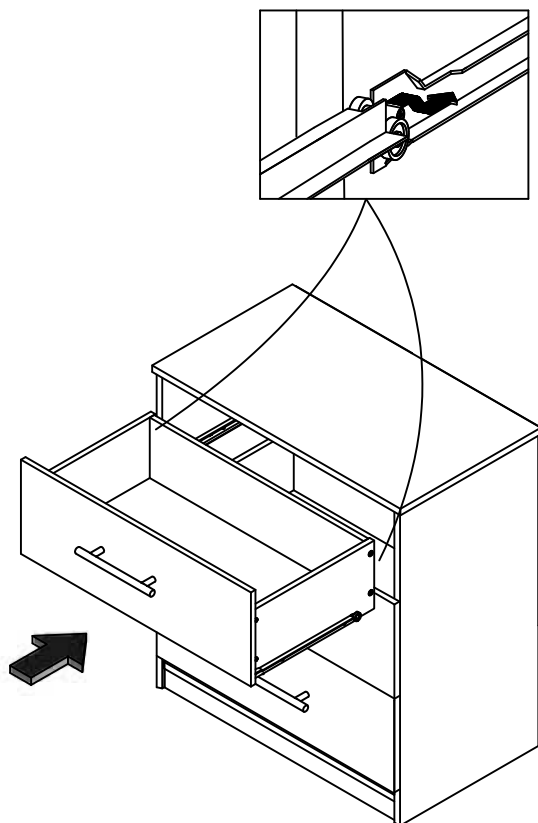

*Unit in Pound(lbs.)

WARNING:

>This unit has been designed to support the maximum loads shown. Exceeding these load limits could cause sagging, instability, product collapse, and/or serious injury.

>DO NOT allow children to climb on unit.

> Put heavier items on lower shelves.



Assembly Instruction

Furinno Lucca Simple Design 3-Drawer Dresser

MODEL : 19154H

01:30

Approx. 1.5 Hours

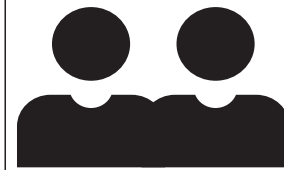

Recomm. 2 Persons

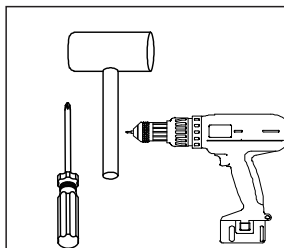

Tool Required

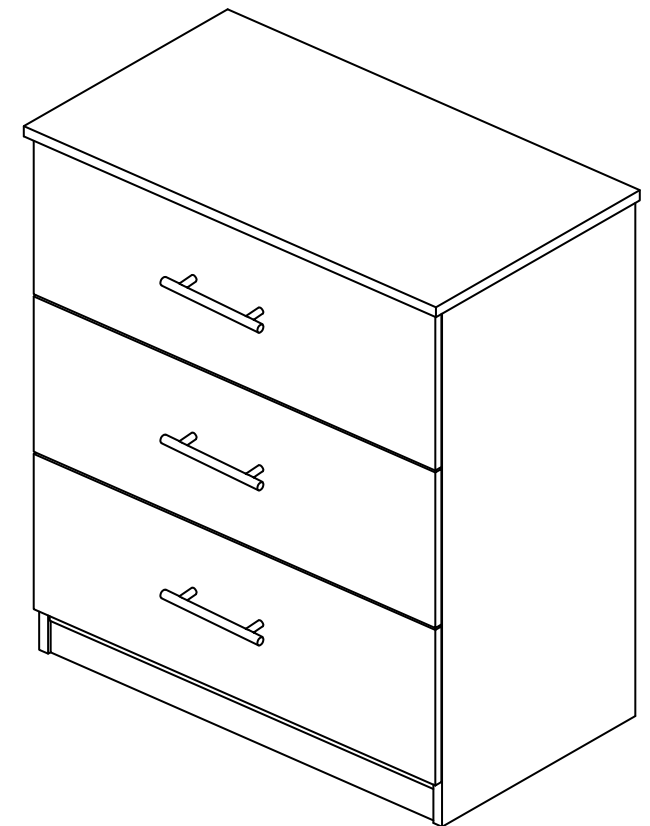

Customer Support

NEED HELP? For replacement requests or product inquiries, please contact our Customer Service Team by emailing us at support@furinno.com. Thank you for selecting Furinno!

www.furinno.com



EXPLODED VIEW

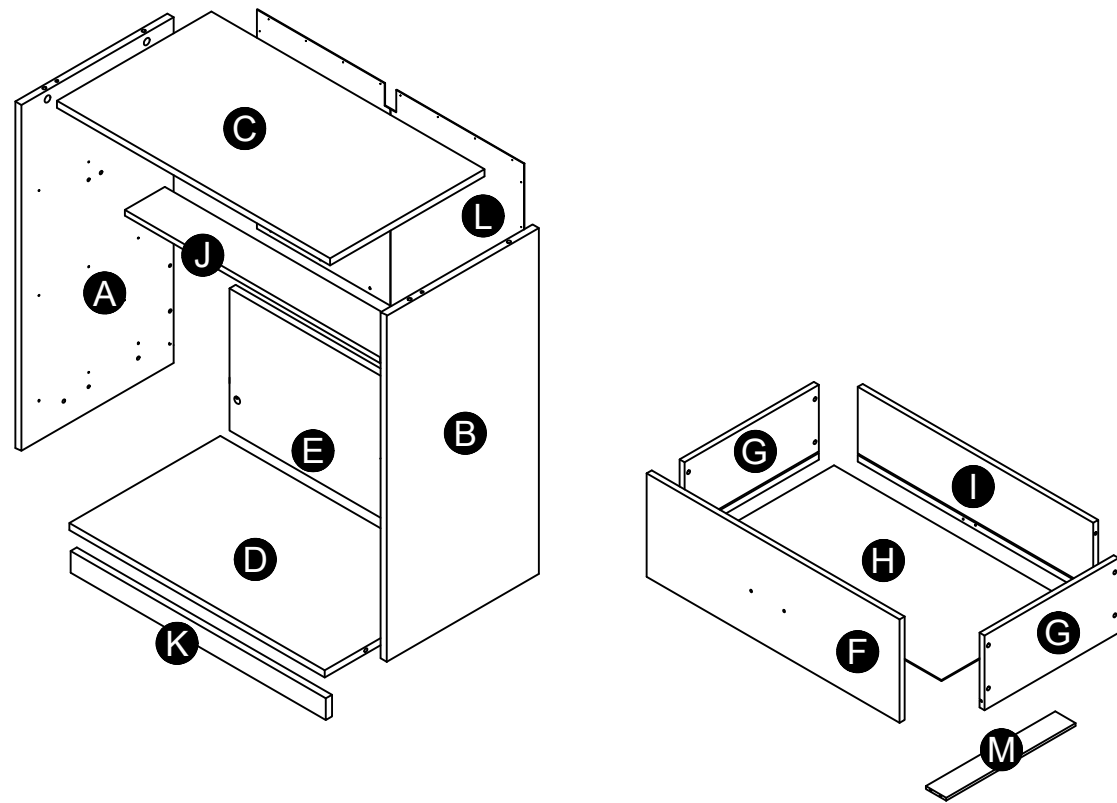

PARTS LIST

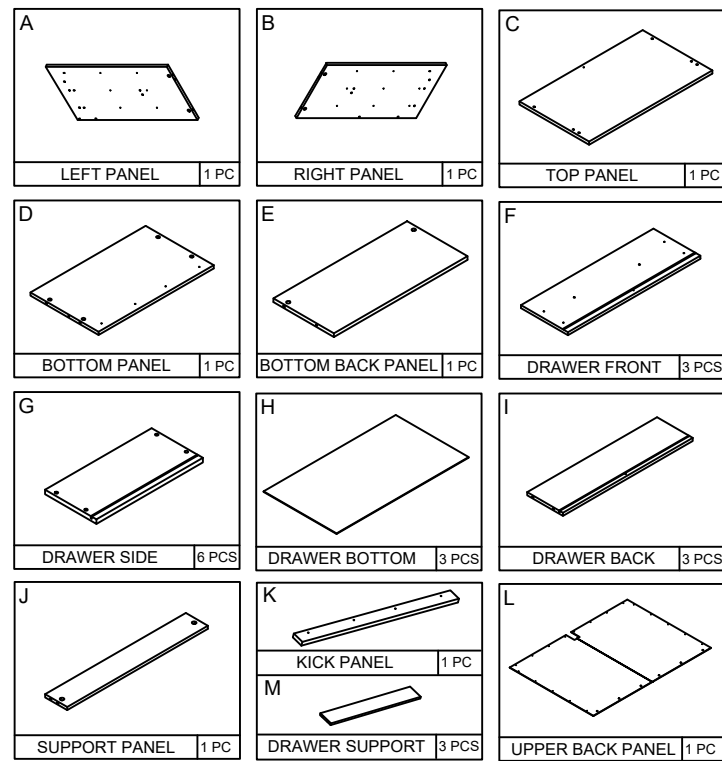

HARDWARE LIST

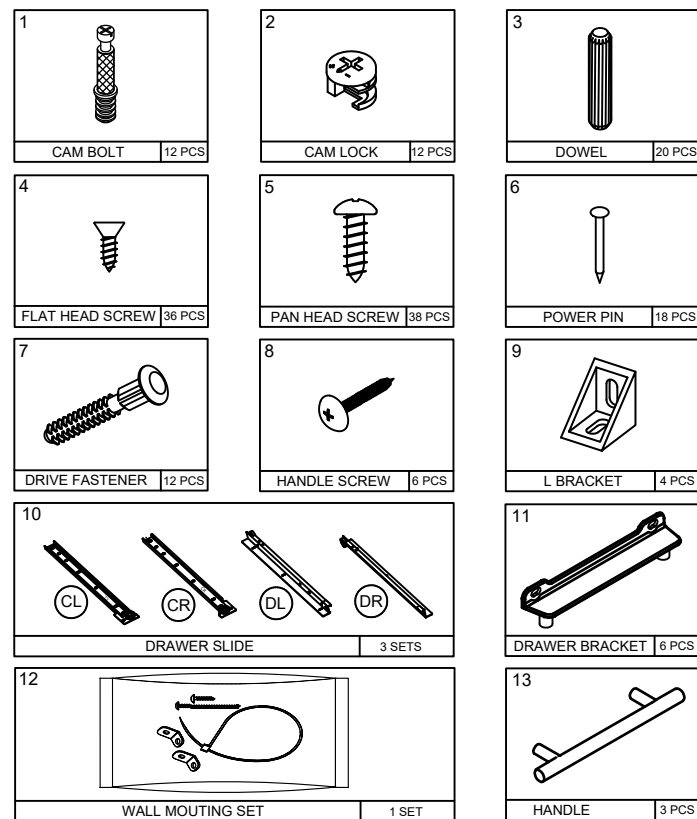

USEFUL HINTS BEFORE YOU START:

1. Read each step carefully before starting.
2. It is important that each step is performed in correct order to avoid difficulties.
3. Identify, soft and count the parts before assembly.
4. Assemble your furniture on packaging cardboard to prevent scratch or damage.
5. Clean the product with mild cleanser using soft damped cloth. Do not use harsh or abrasive cleanser.
6. Using incompatible hardware might cause damage to product.

STEP 9

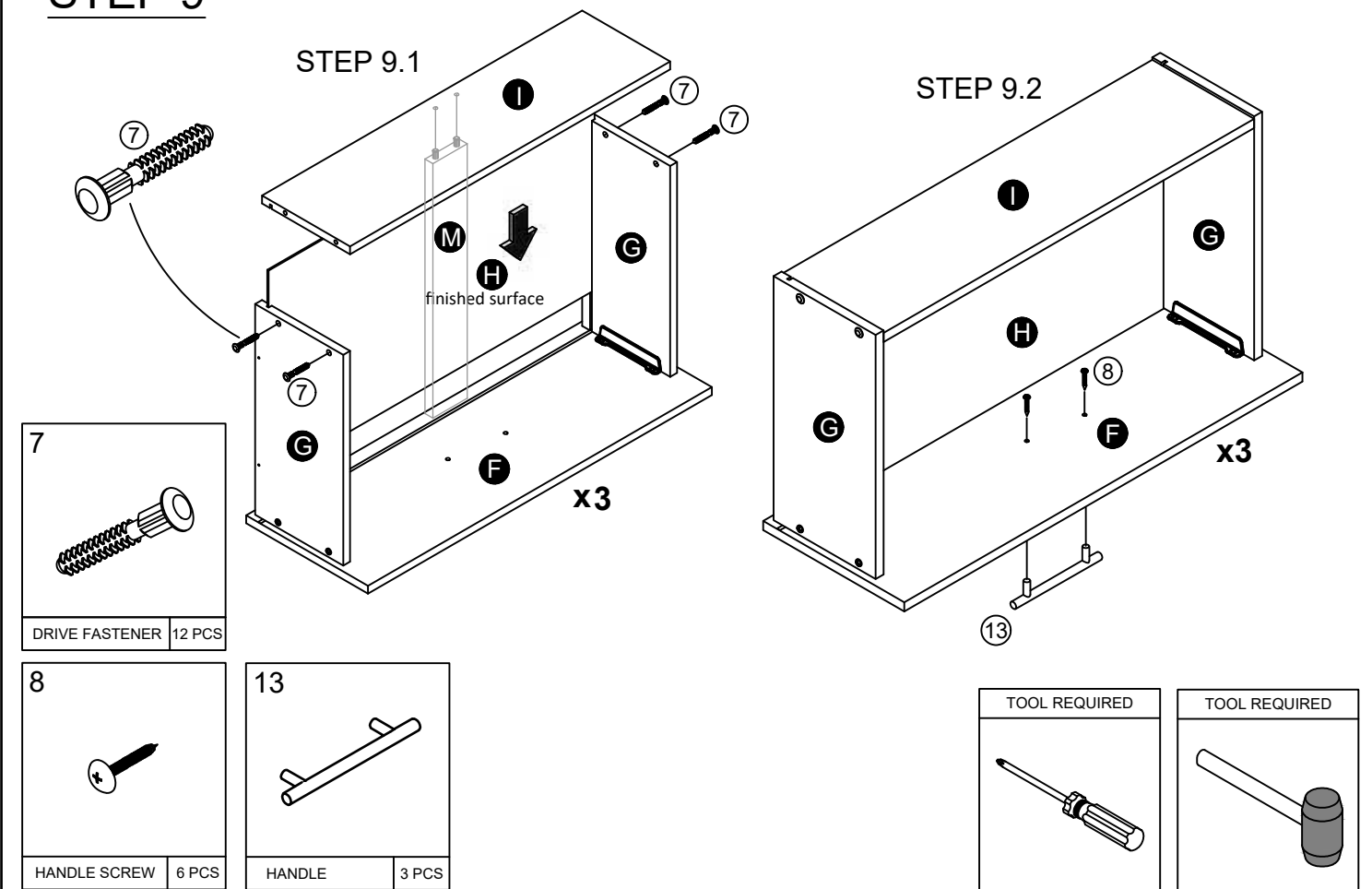

STEP 10

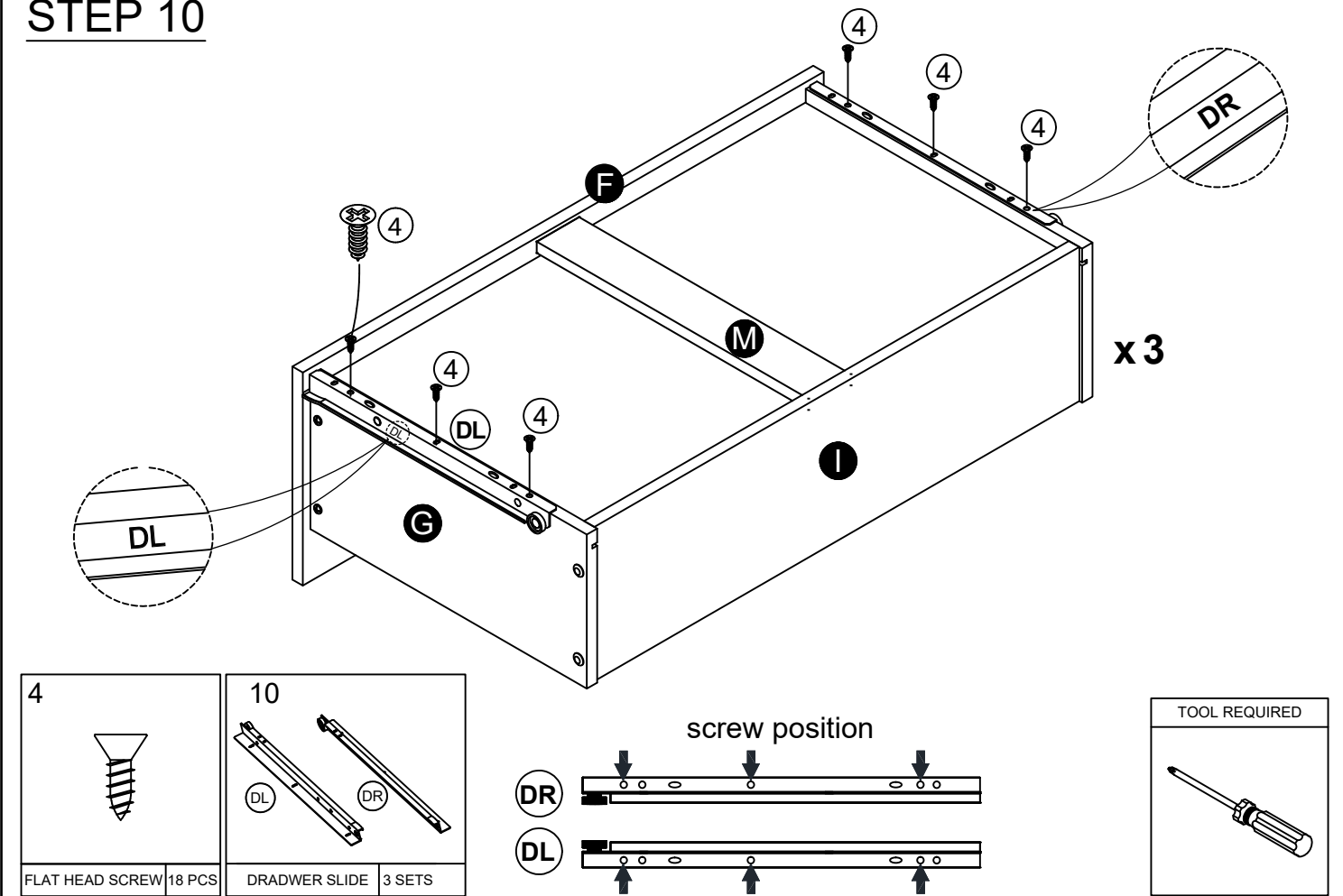

STEP 7

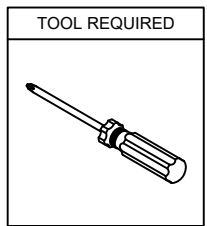
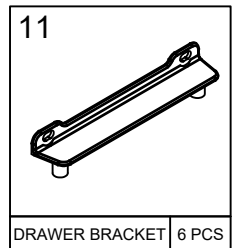
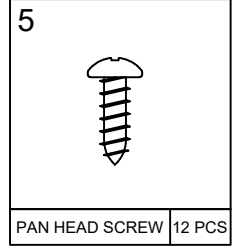
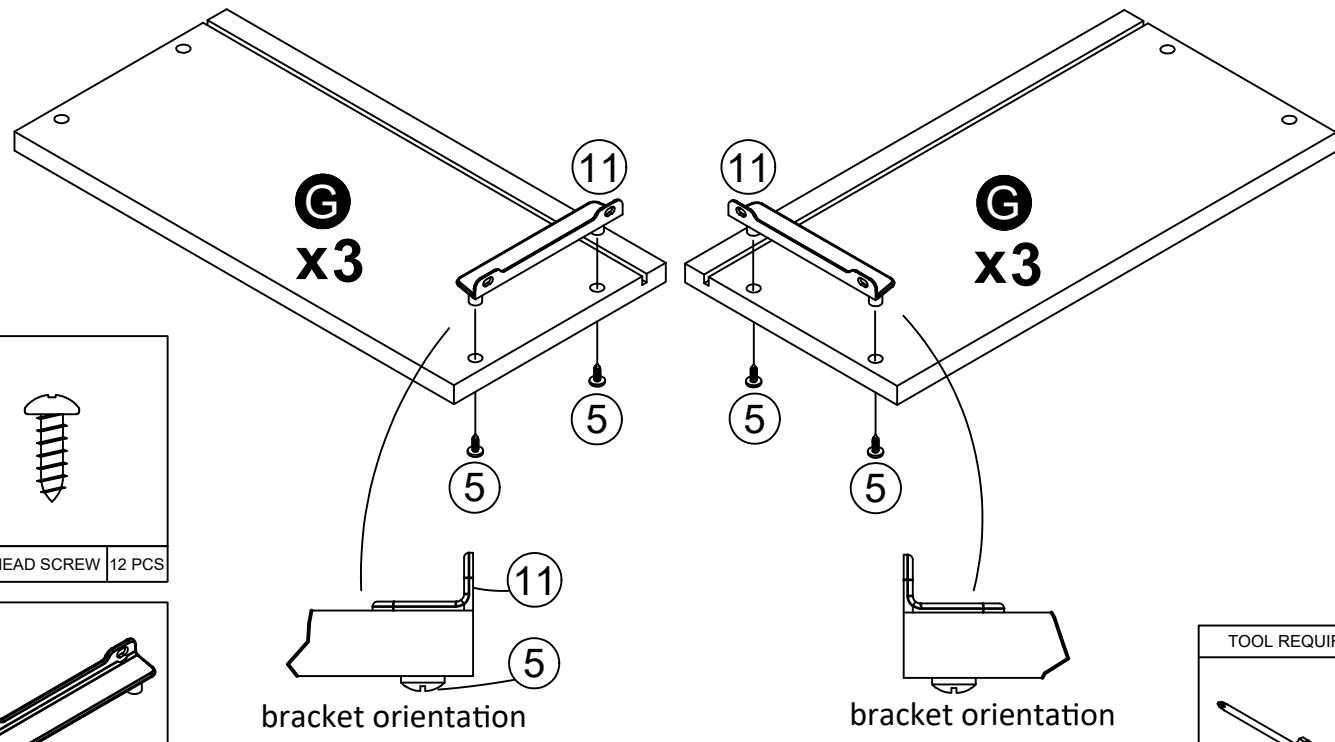

STEP 1

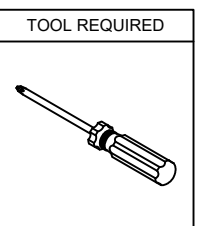
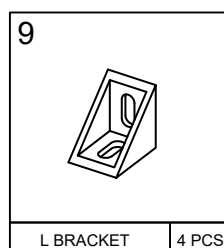
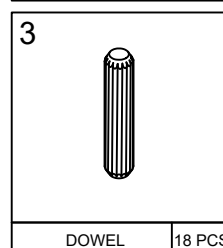
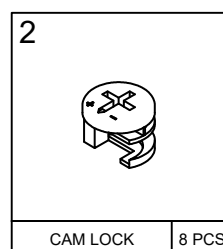
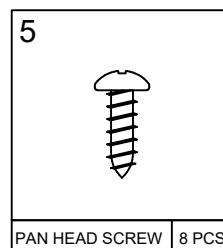
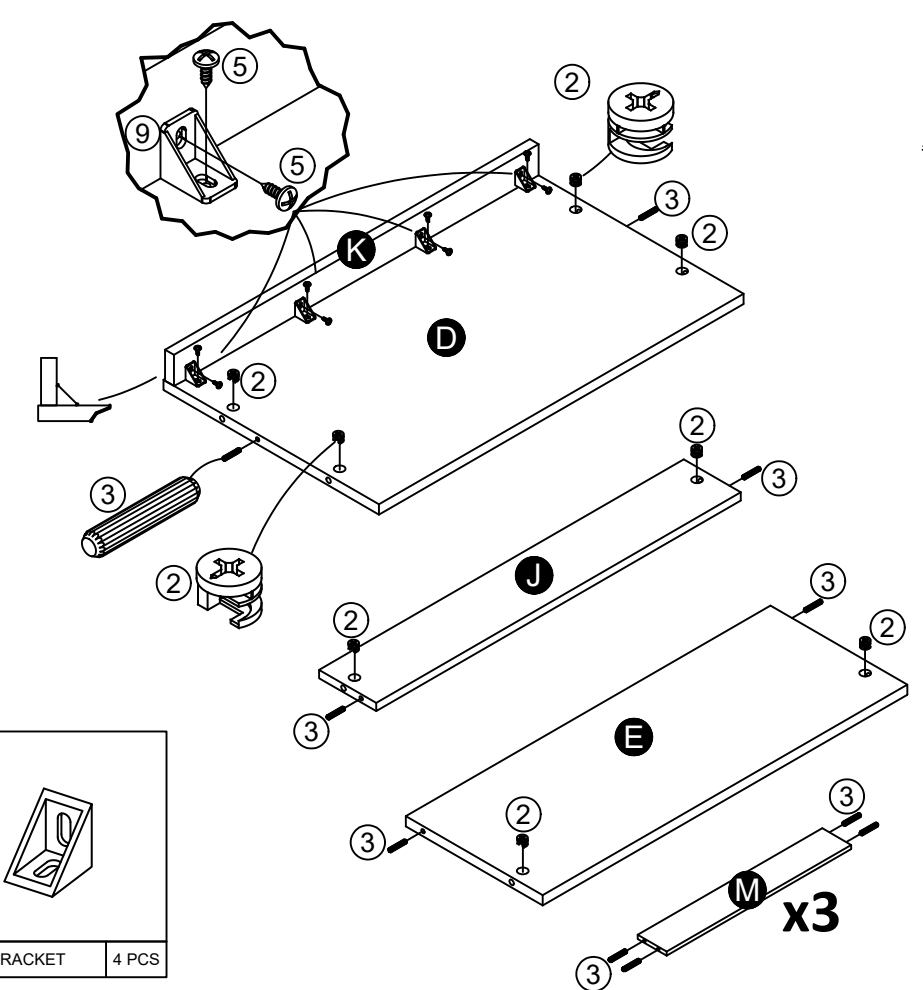

STEP 8

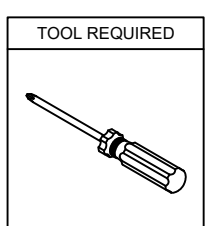
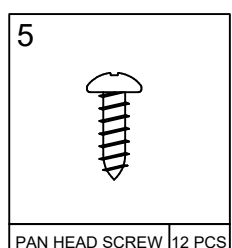
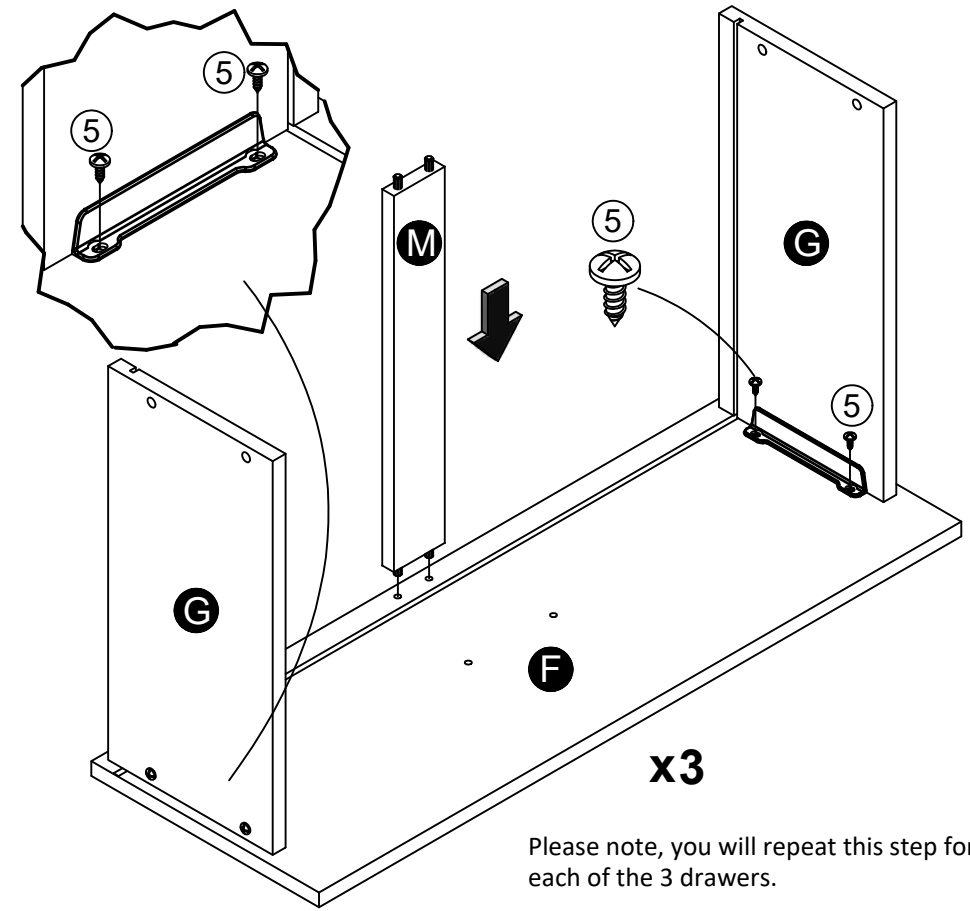

Please note, you will repeat this step for each of the 3 drawers.

STEP 2

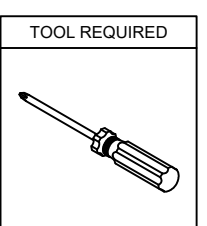
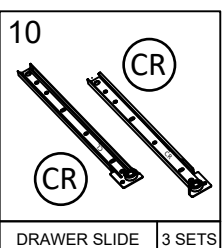
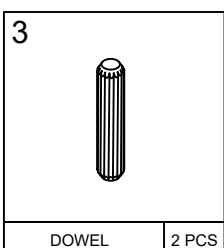
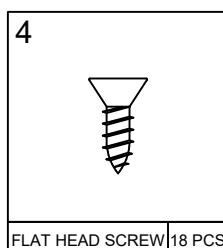
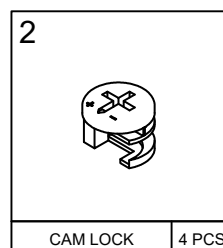
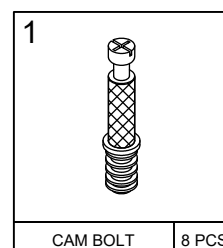
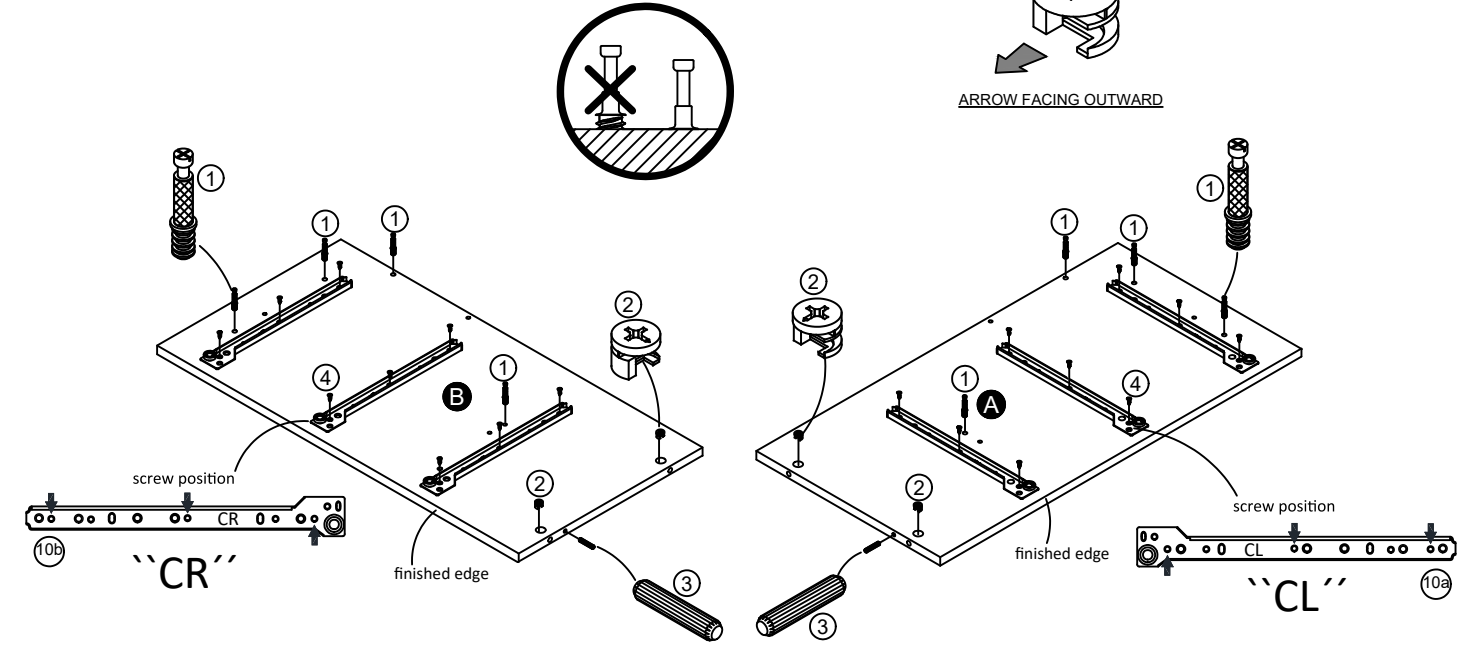

STEP 3

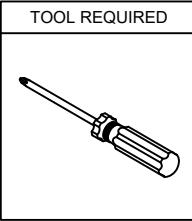
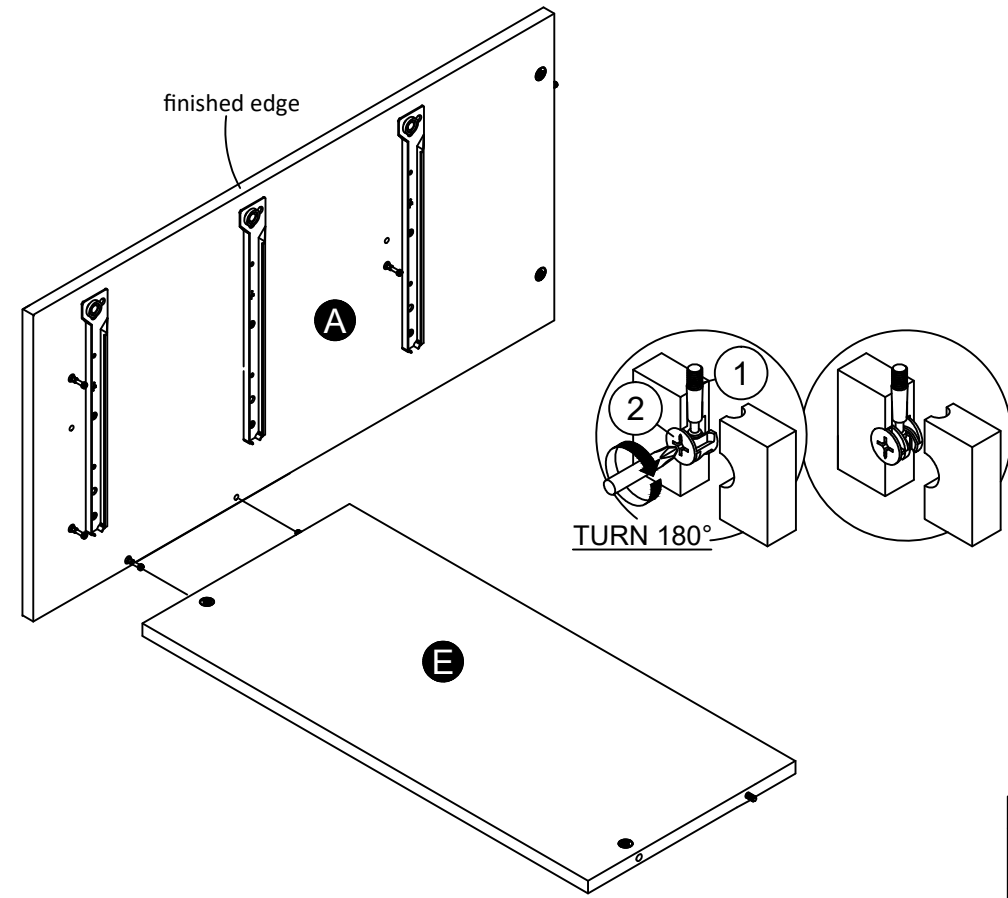

STEP 4

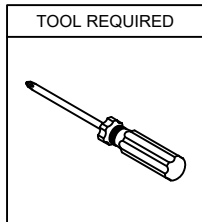
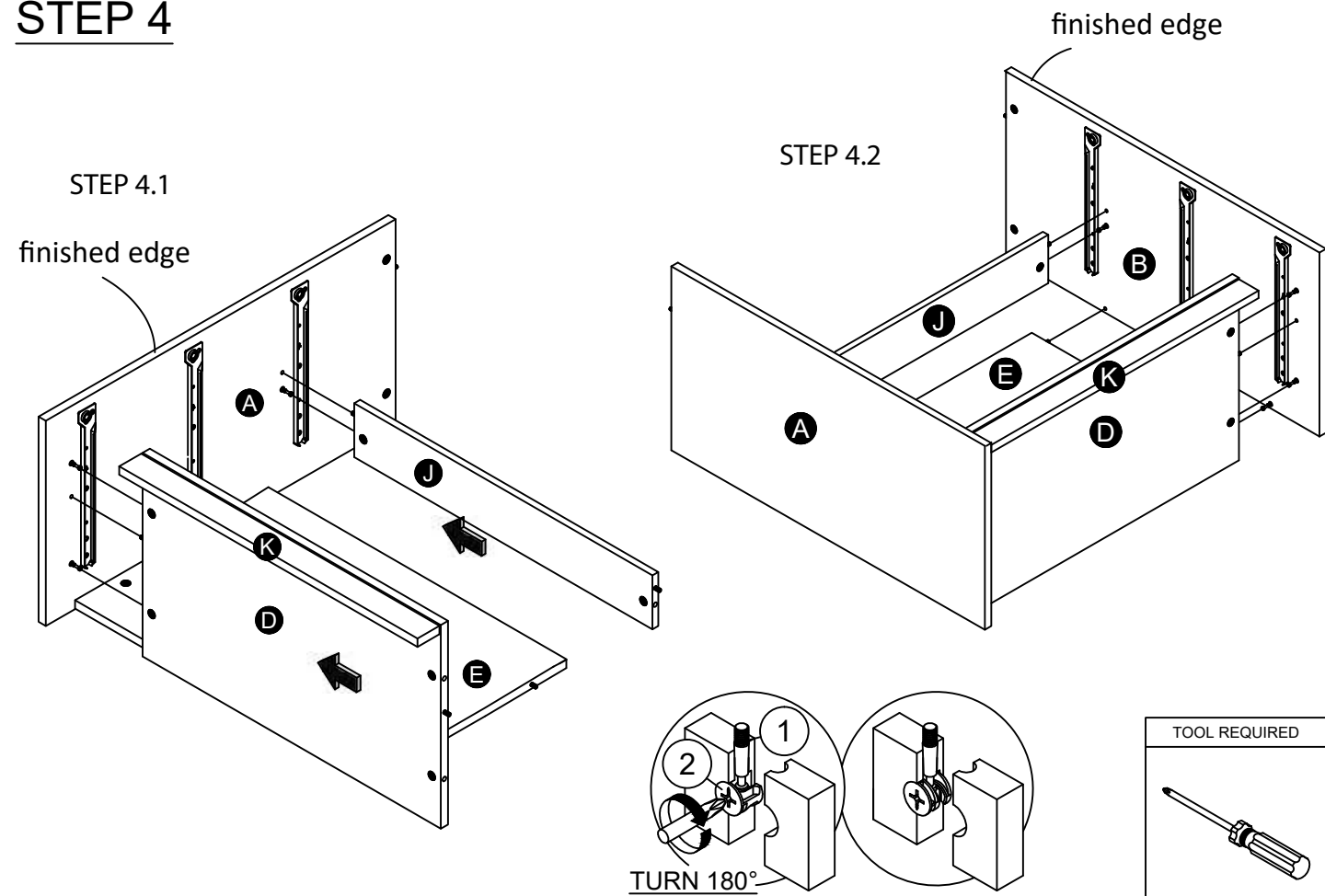

STEP 5

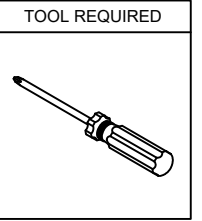
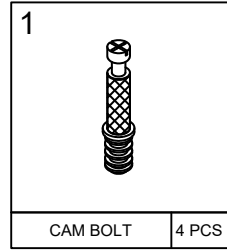
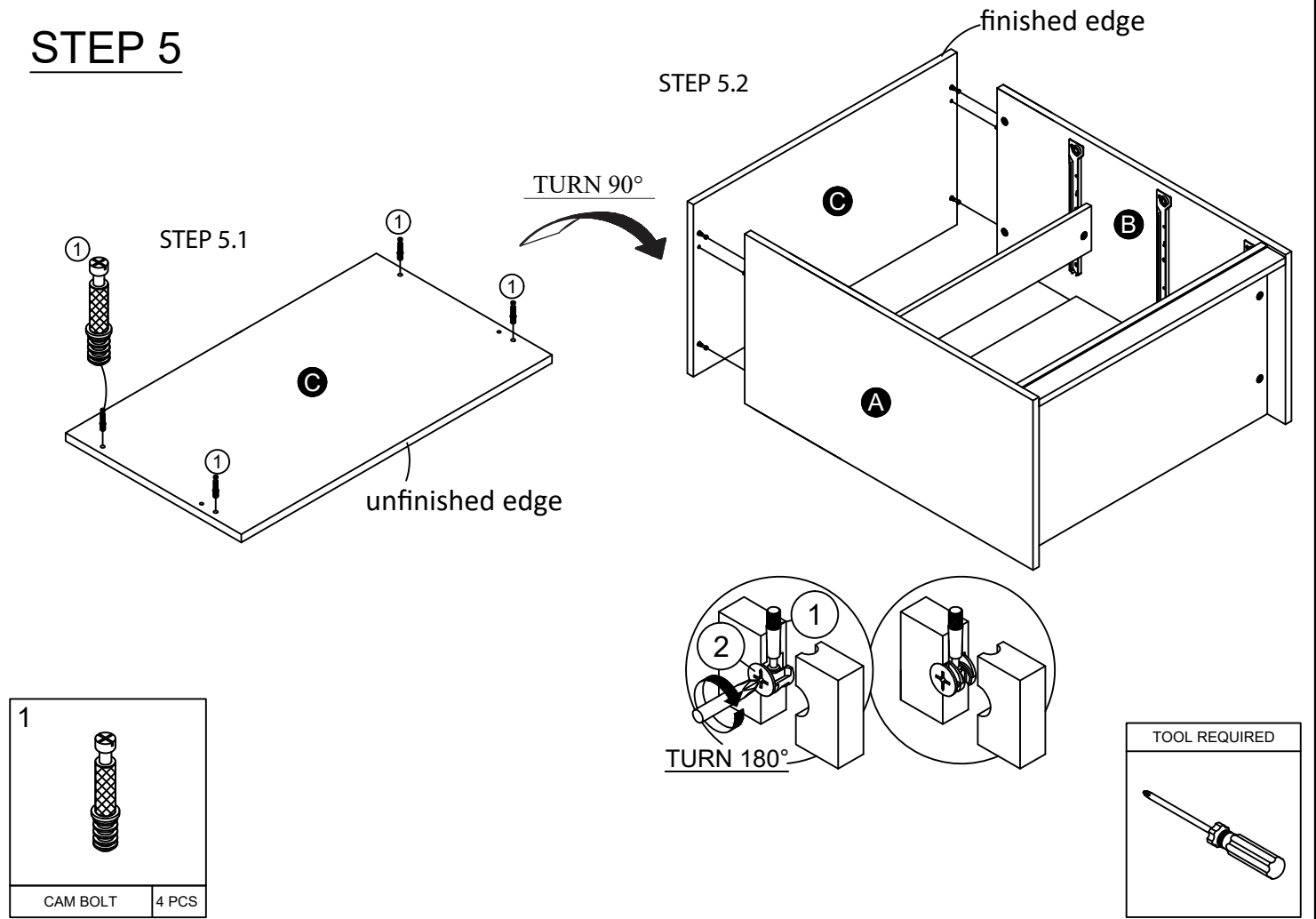

STEP 6

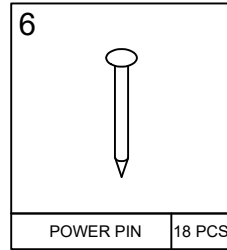
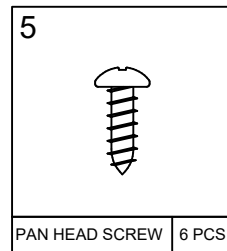
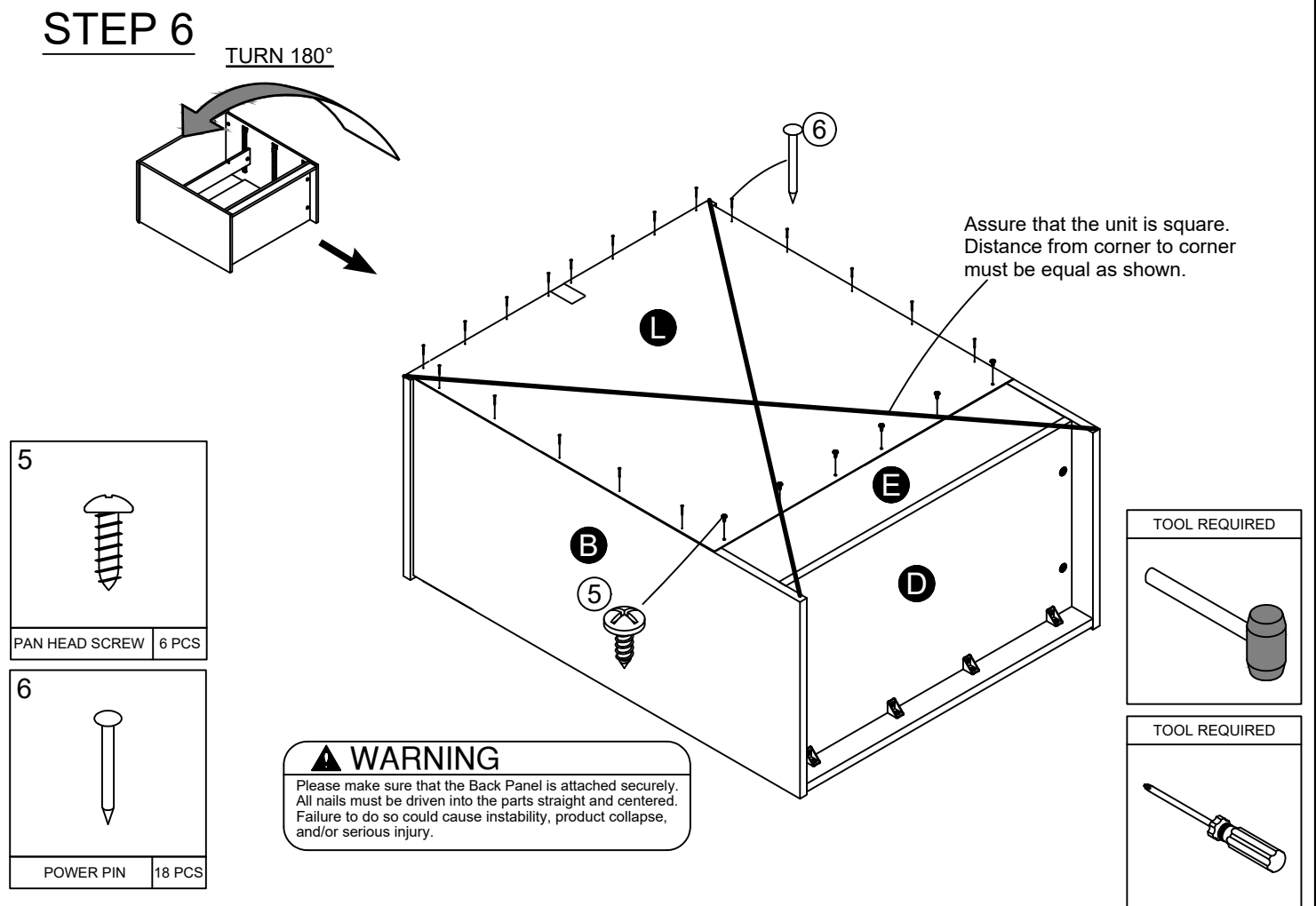

WARNING
 Please make sure that the Back Panel is attached securely. All nails must be driven into the parts straight and centered. Failure to do so could cause instability, product collapse, and/or serious injury.

