

Recommended Maximum Weight

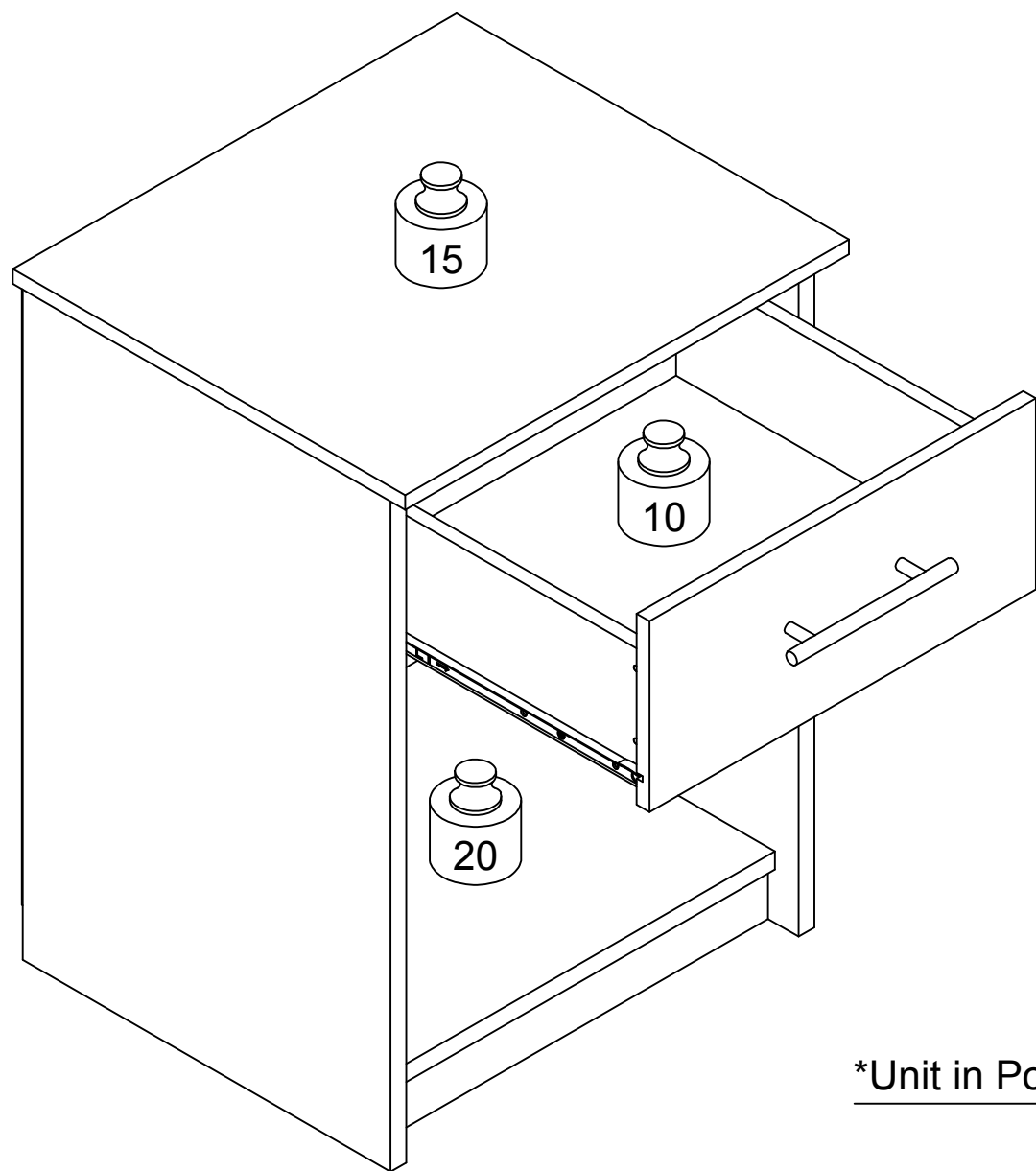

*Unit in Pound(lbs.)

WARNING:

>This unit has been designed to support the maximum loads shown. Exceeding these load limits could cause sagging, instability, product collapse, and/or serious injury.

>DO NOT allow children to climb on unit.

> Put heavier items on lower shelves.



Assembly Instruction

Furinno Lucca Nightstand With One Drawer

MODEL : 19153H (Set of 2)

01:00

Approx. 1 Hour



Recomm. 1 Person

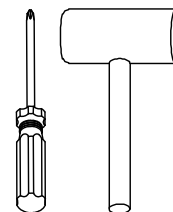

Tool Required

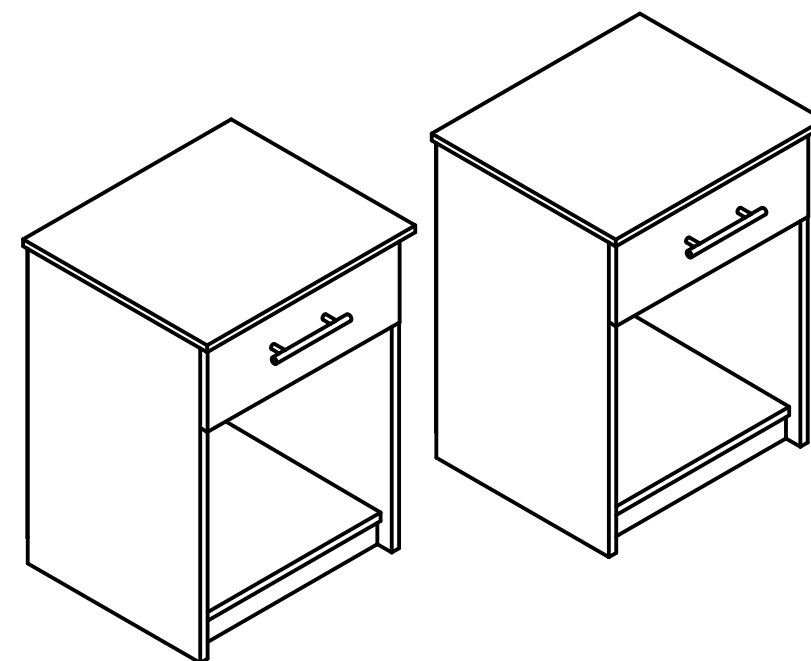

Customer Support

NEED HELP? For replacement requests or product inquiries, please contact our Customer Service Team by emailing us at support@furinno.com. Thank you for selecting Furinno!

www.furinno.com



EXPLODED VIEW

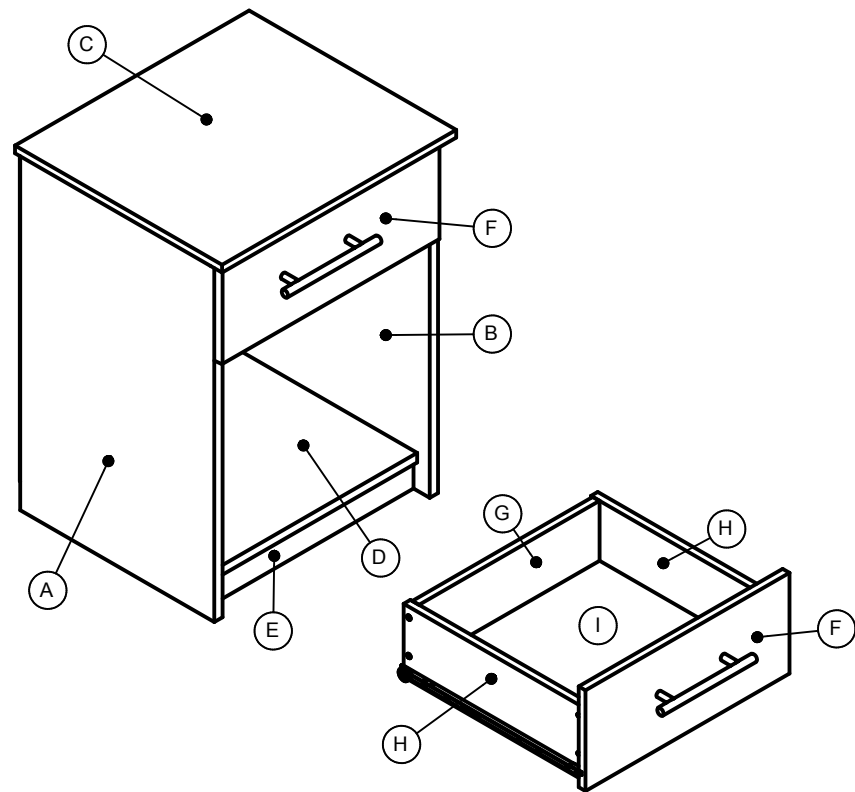

PARTS LIST

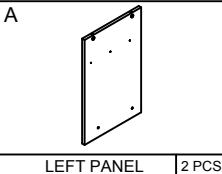
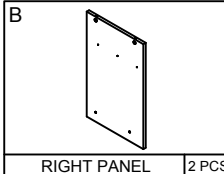
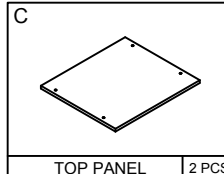
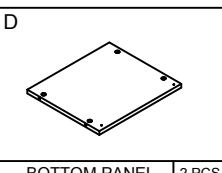
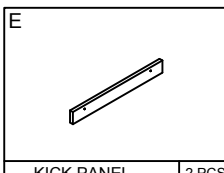
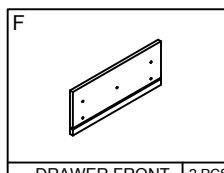
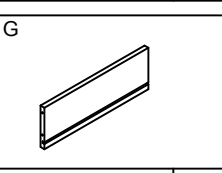
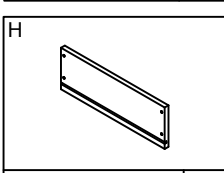
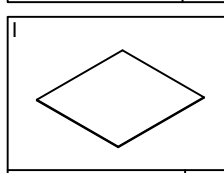
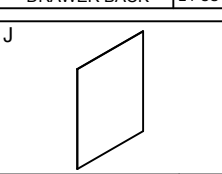
 LEFT PANEL 2 PCS	 RIGHT PANEL 2 PCS	 TOP PANEL 2 PCS
 BOTTOM PANEL 2 PCS	 KICK PANEL 2 PCS	 DRAWER FRONT 2 PCS
 DRAWER BACK 2 PCS	 DRAWER SIDE 4 PCS	 DRAWER BOTTOM 2 PCS
 BACK PANEL 2 PCS		

*All the part quantity are for two sets.

HARDWARE LIST

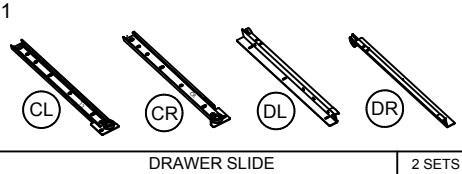
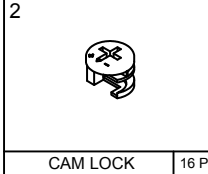
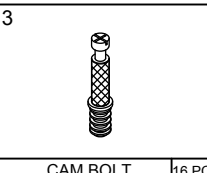
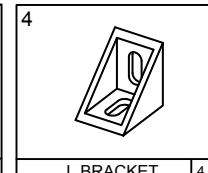
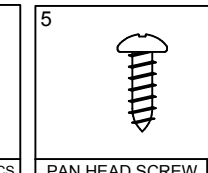
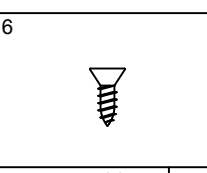
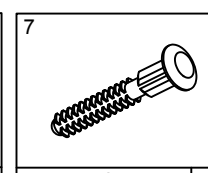
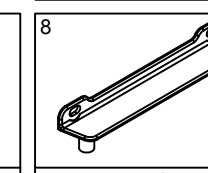
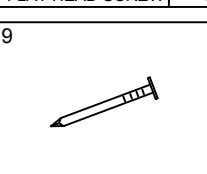
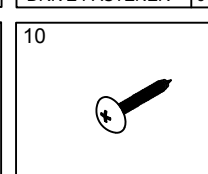
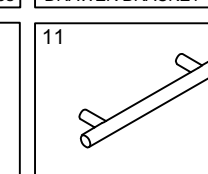
 DRAWER SLIDE 2 SETS	 CAM LOCK 16 PCS
 CAM BOLT 16 PCS	 L BRACKET 4 PCS
 PAN HEAD SCREW 24 PCS	
 FLAT HEAD SCREW 24 PCS	 DRIVE FASTENER 8 PCS
 DRAWER BRACKET 4 PCS	
 POWER PIN 40 PCS	 HANDLE SCREW 4 PCS
	 HANDLE KNOB 2 PCS

*All the hardware quantity are for two sets.

USEFUL HINTS BEFORE YOU START:

1. Read each step carefully before starting.
2. It is important that each step is performed in correct order to avoid difficulties.
3. Identify, soft and count the parts before assembly.
4. Assemble your furniture on packaging cardboard to prevent scratch or damage.
5. Clean the product with mild cleanser using soft damped cloth. Do not use harsh or abrasive cleanser.
6. Using incompatible hardware might cause damage to product.

STEP 9

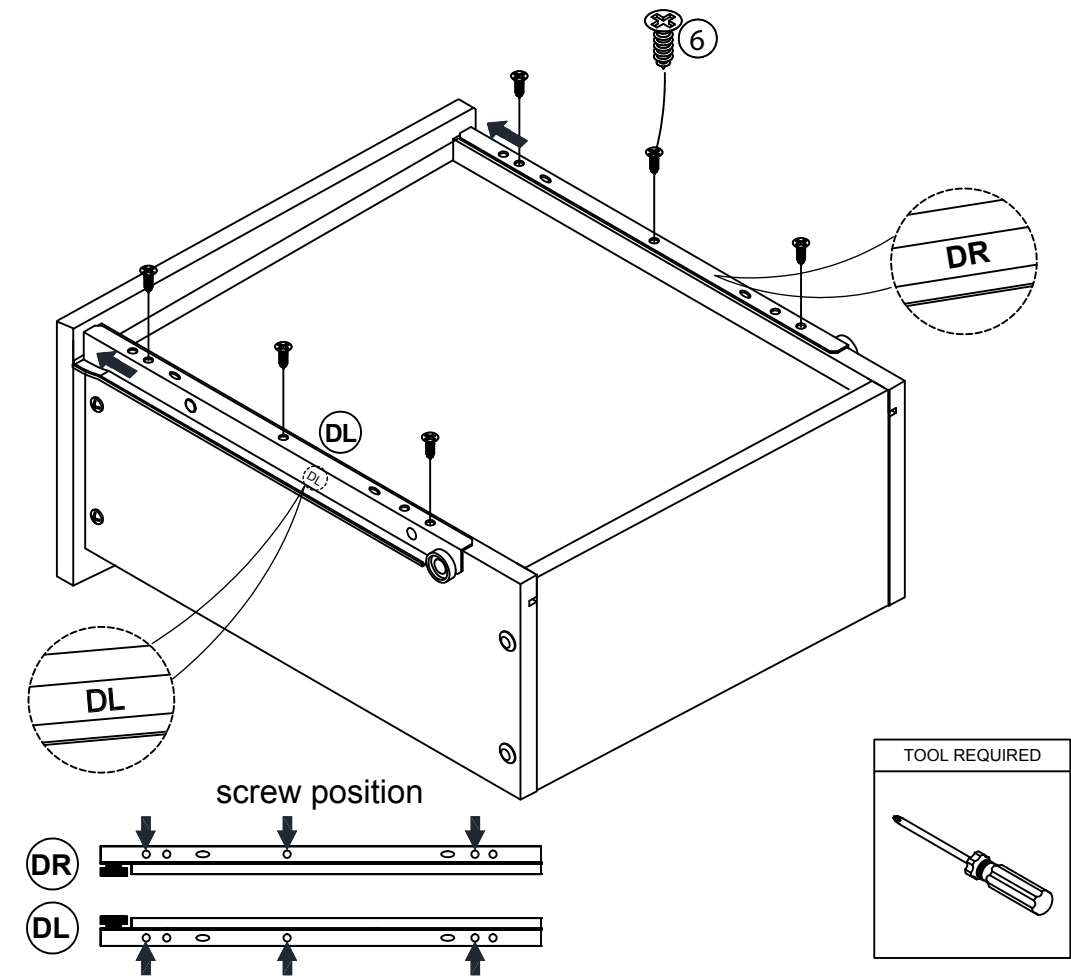
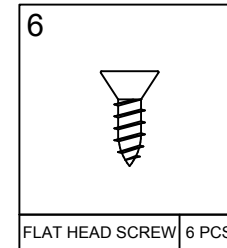
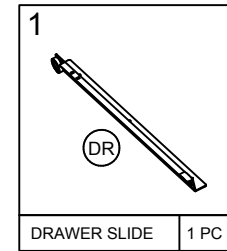
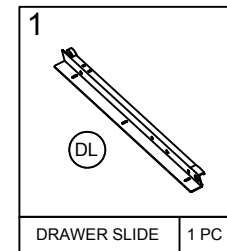

STEP 10

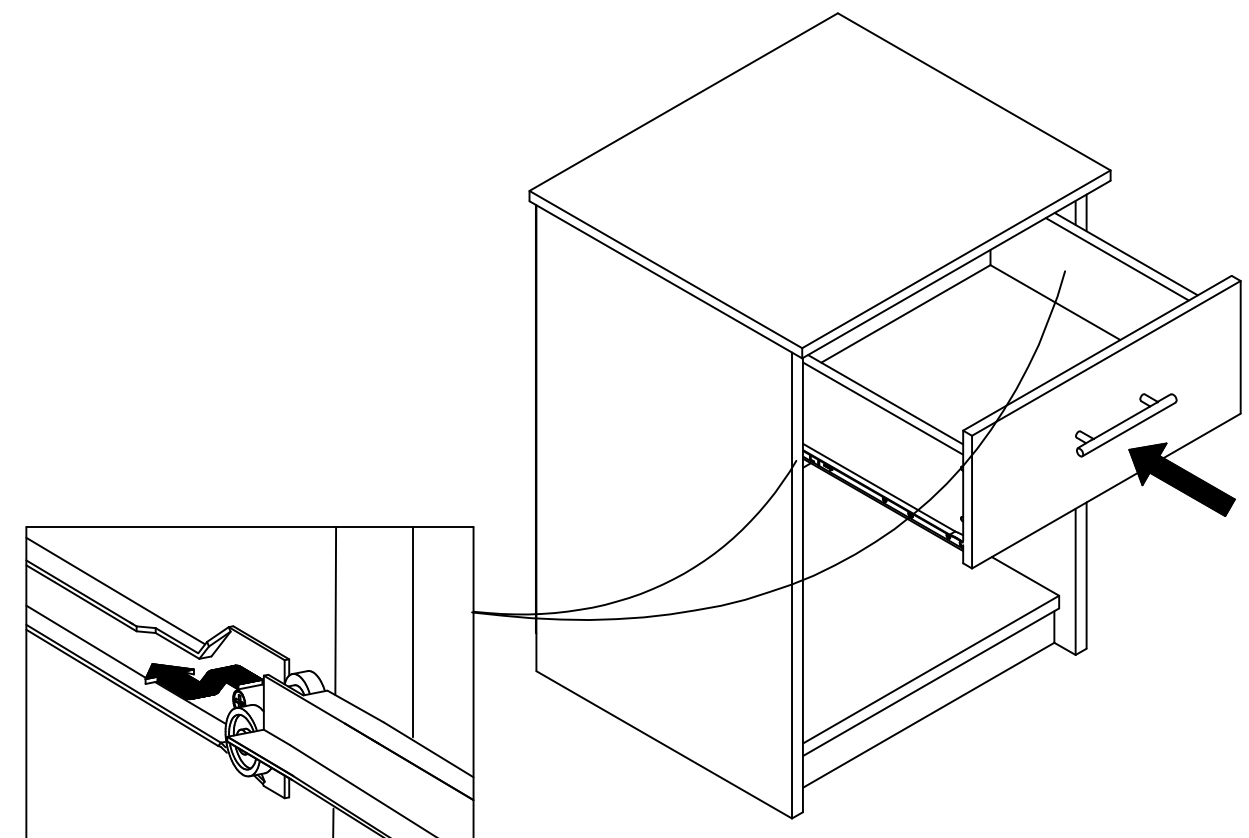

STEP 7

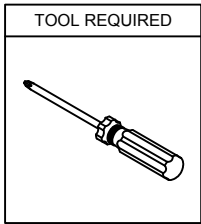
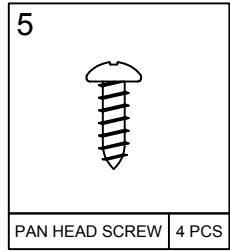
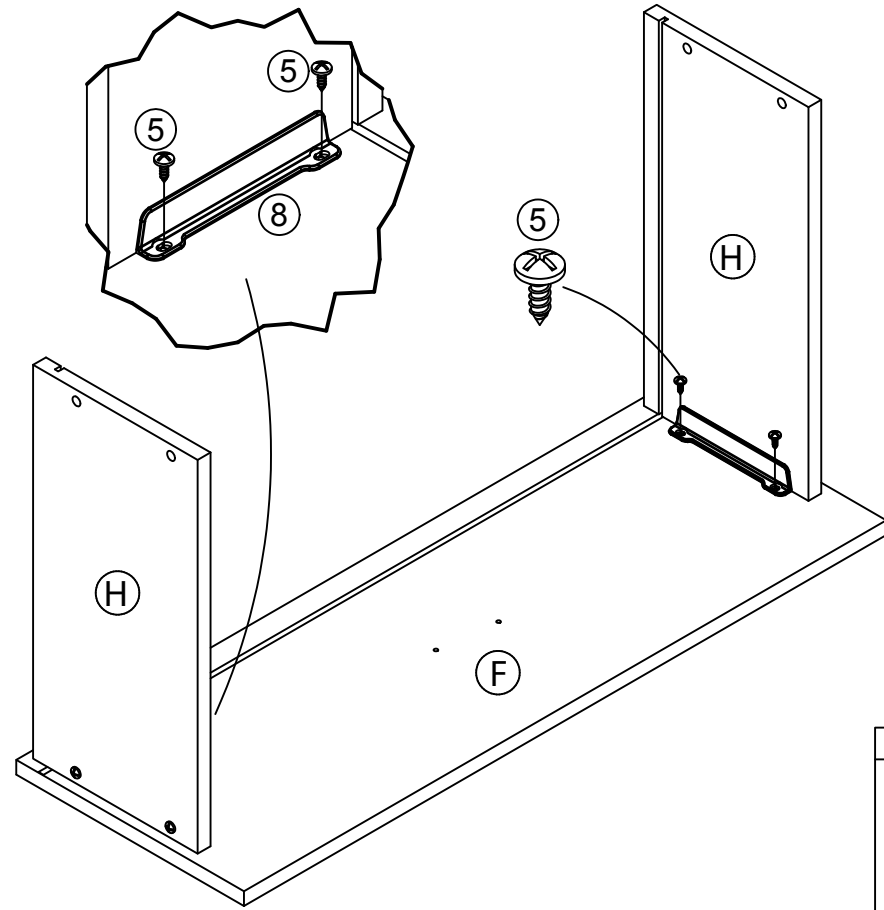

STEP 8

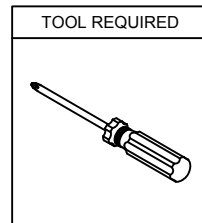
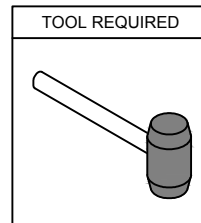
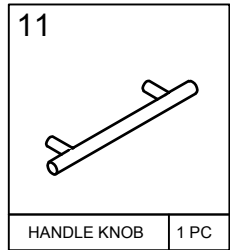
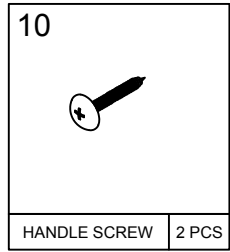
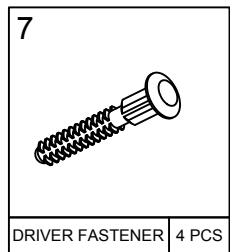
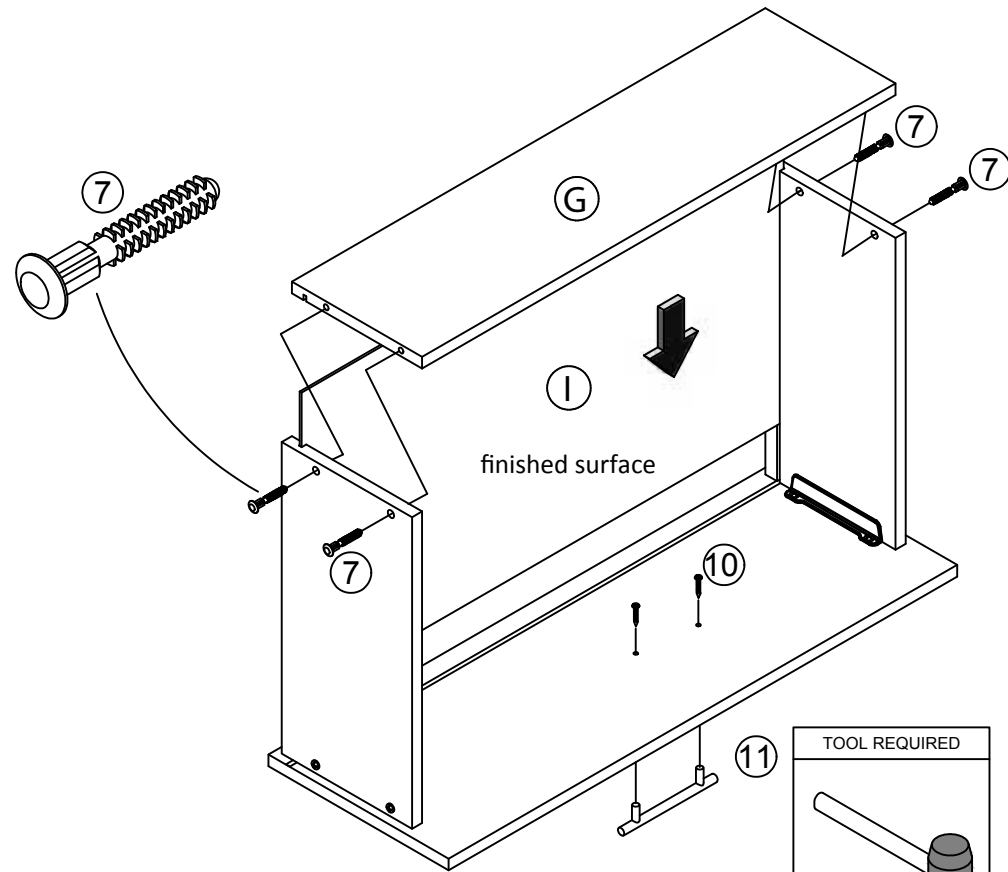

STEP 1

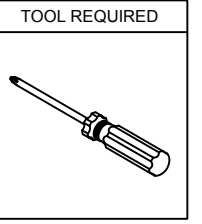
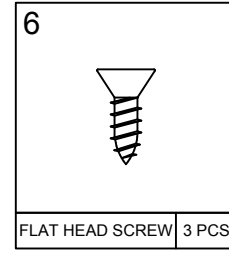
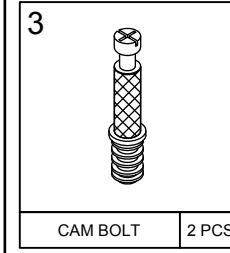
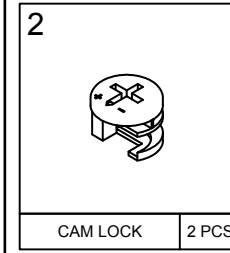
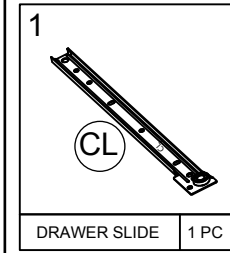
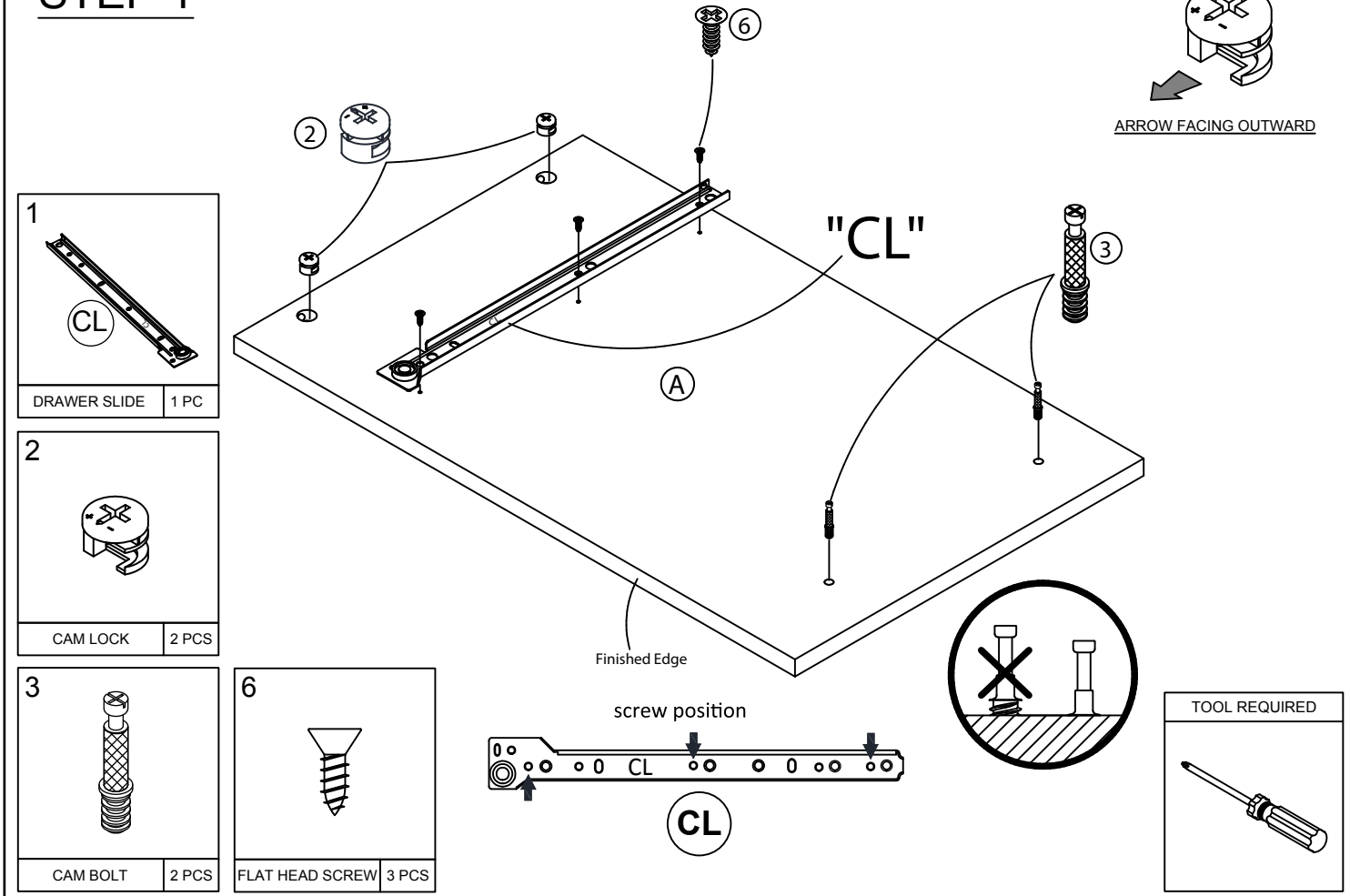

STEP 2

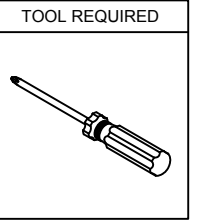
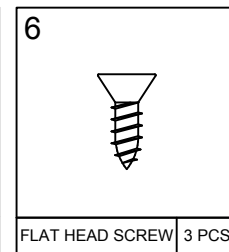
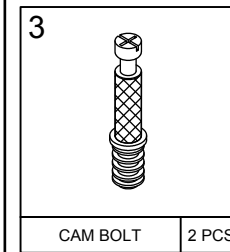
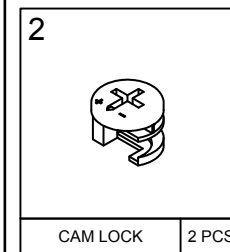
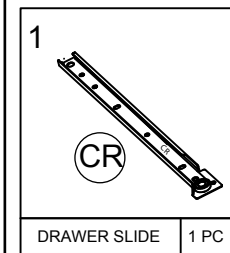
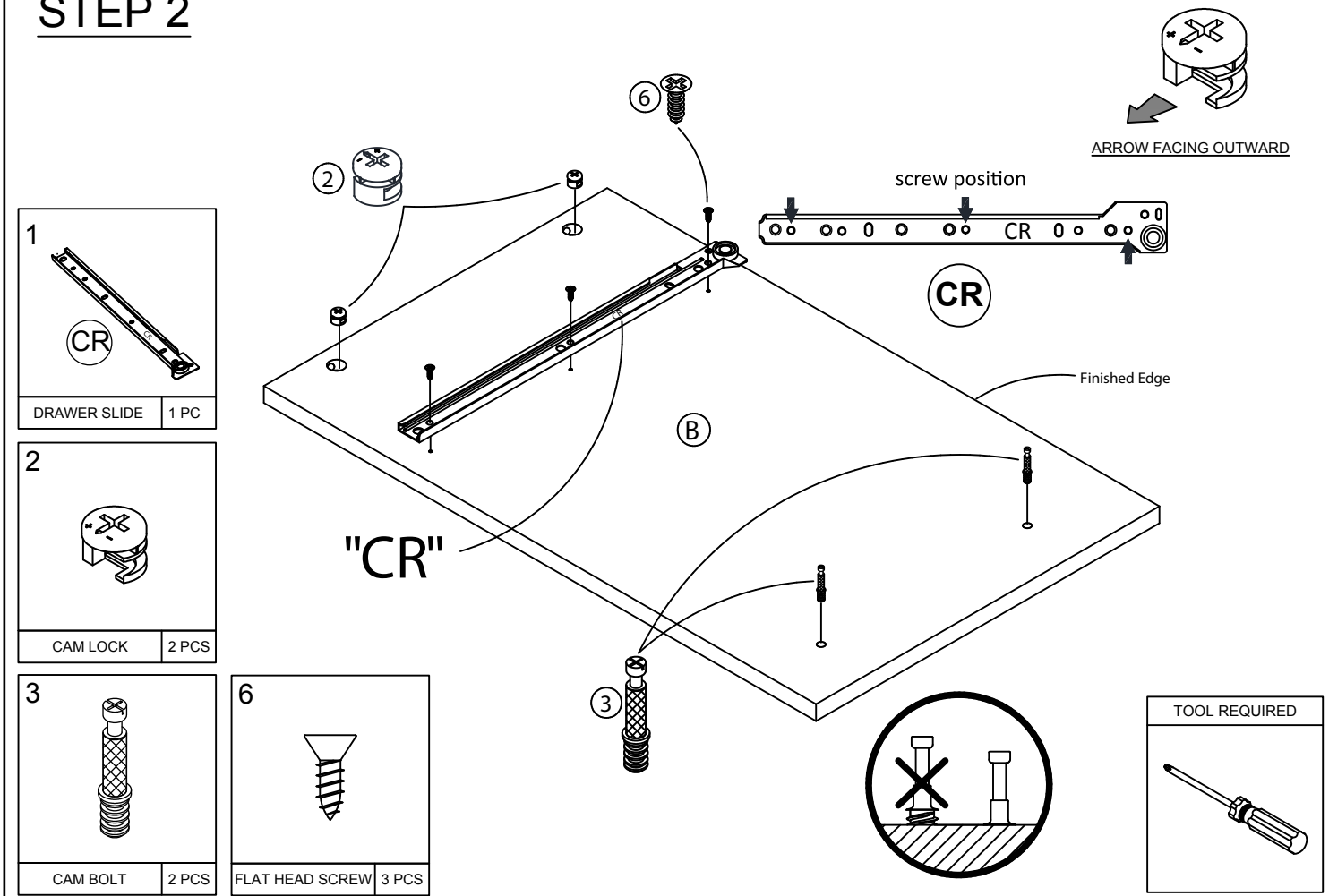

STEP 3

STEP 3.1

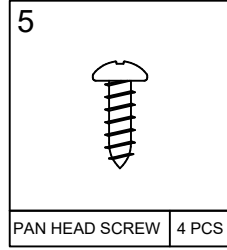
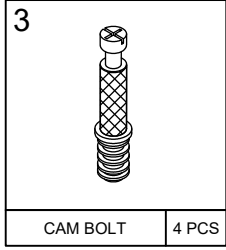
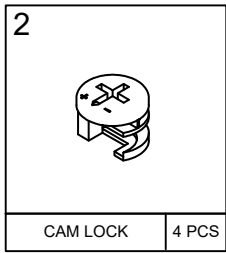
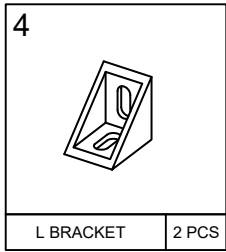
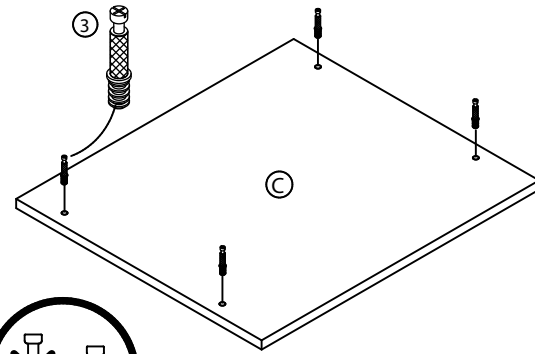

Finished Edge

STEP 3.2

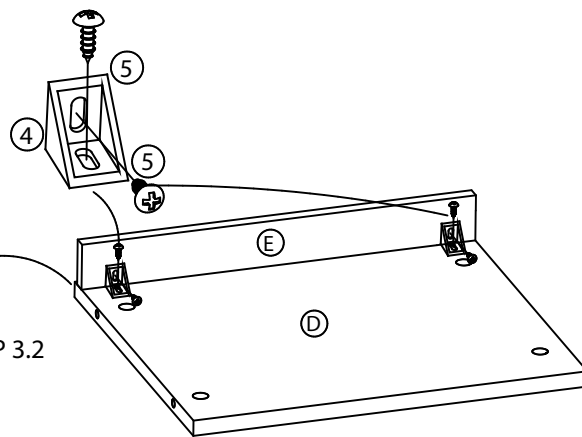

STEP 3.3

Finished Edge

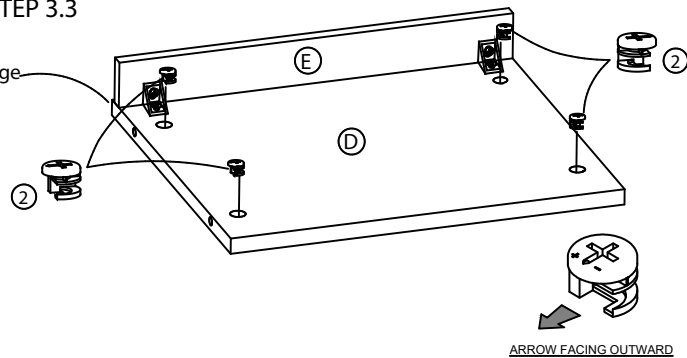

TOOL REQUIRED

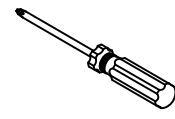

ARROW FACING OUTWARD

STEP 4

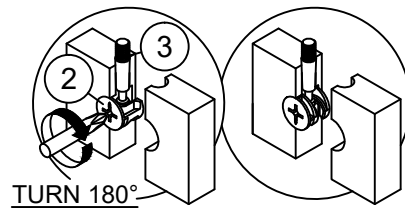

TURN 180°

STEP 4.1

Finished Edge

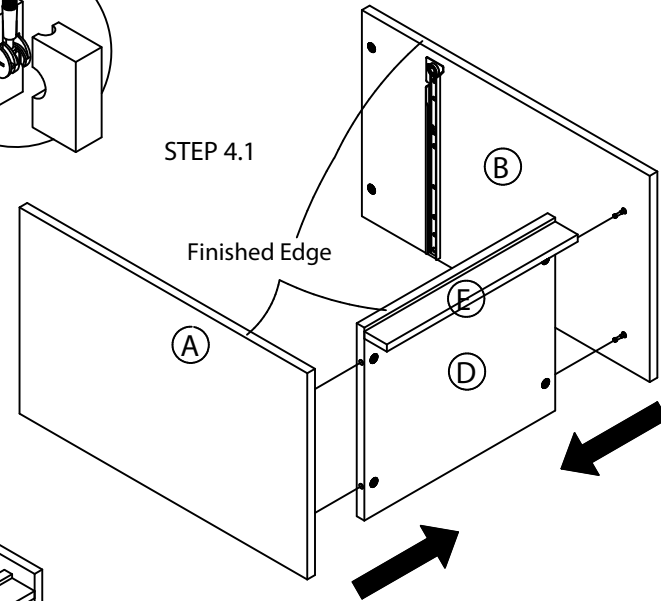

TOOL REQUIRED

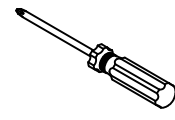

STEP 4.2

Finished Edge

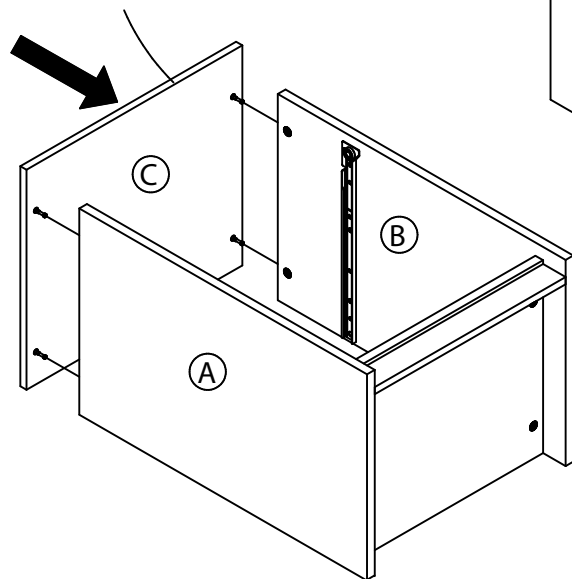

STEP 5

TURN 180°

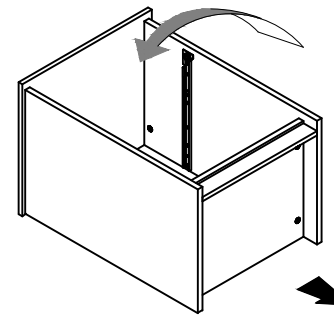

Unfinished Surface

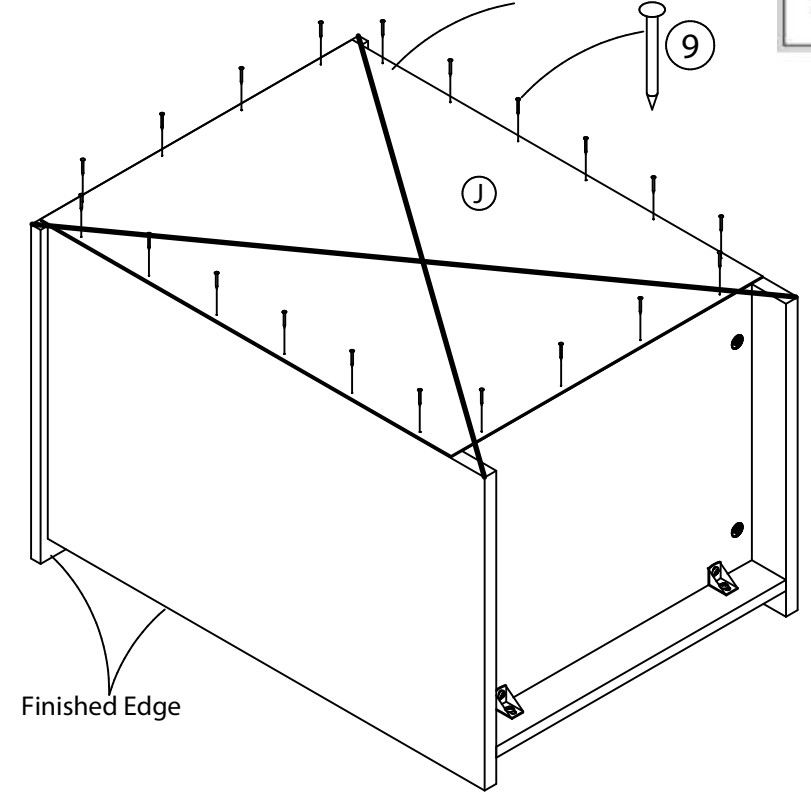

Finished Edge

TOOL REQUIRED

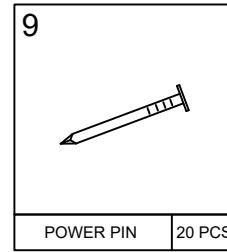
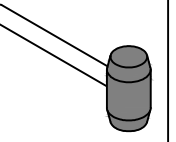

STEP 6

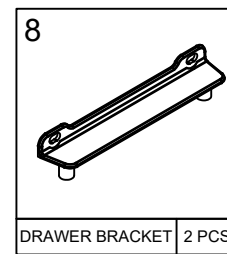
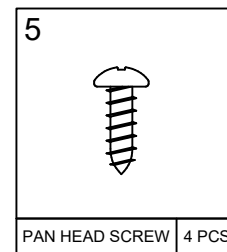
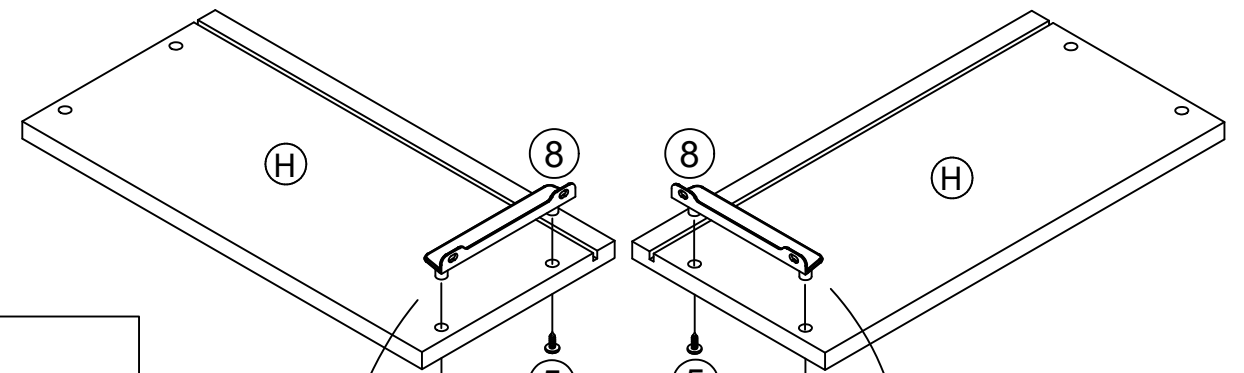

SIDE VIEW

SIDE VIEW

TOOL REQUIRED

