

gemini
ITALY

2-TIERS MINI MULTI-FUNCTIONAL
FOOD STEAMER
迷你電子多功能雙層電蒸籠
MODEL NO. 型號 : GFS2DB-V3

Before using your product for first time, please read this instruction manual.
在使用本產品前，請仔細閱讀本說明書並保存好。

SAFETY INTRUCTIONS

1. Please read the operating instructions carefully before use to avoid damage or danger caused by improper operation.
2. Children under 8 years old, individuals with disabilities, or those with impaired mental or sensory abilities and lacking operational knowledge or experience should not operate this product alone. If operation is necessary, a responsible person must supervise and ensure safety.
3. If the product malfunctions, please contact the distributor or a qualified technician. Do not attempt to repair it yourself to avoid danger.
4. Connect the power supply according to the specifications listed on the product label.
5. This product is intended for indoor household use only. It is not suitable for commercial use or for use in high-humidity environments.
6. Before use, ensure the socket is properly grounded and the input voltage is 220–240V~ 50/60Hz.
7. If the power cord is damaged, please contact the service department for replacement.
8. Do not press the control buttons with excessive force to avoid damage.
9. If any issue occurs during use, unplug the power cord immediately. Do not plug or unplug with wet hands to avoid electric shock.
10. Do not pull, press, or hang the power cord with sharp or pointed objects. Keep it away from heat and moisture sources.
11. Do not insert metal or foreign objects into the ventilation holes or gaps, as this may damage the circuitry.
12. Do not place the product on or near heat sources such as ovens or heaters.
13. Do not use the product on uneven or slanted surfaces to avoid tipping, injury, or fire hazards.
14. Do not use the product on or near heat-sensitive surfaces such as carpets or plastic stools. Do not place items that may be damaged by steam above the product.
15. This product is not suitable for use or play by children, individuals with

mental illness, or those lacking experience.

16. The pot body may become hot during use, which is normal. When pouring water, use the handle to lift the pot. Do not touch the hot surface directly to avoid burns.
17. In case of dry burning, allow the unit to cool before adding water or unplugging the power. Do not touch the heating element to avoid burns.
18. Keep the heating plate clean. After extended use, clean any dirt or residue from the surface.
19. Steam may be emitted from the steam outlet during use, which can cause burns. Please handle with care.
20. Do not allow liquids to enter the interior of the product during cleaning. Do not immerse the power cord, plug, or the entire unit in water to avoid danger.
21. The PTC heating element inside the product is not intended to come into direct contact with food.
22. This product has an overheat protection function. If the water runs dry before the operation ends, the display will show “E00” as a warning. Add water to resume normal operation.

PRODUCT REVIEW

This unit is for HOUSEHOLD USE ONLY

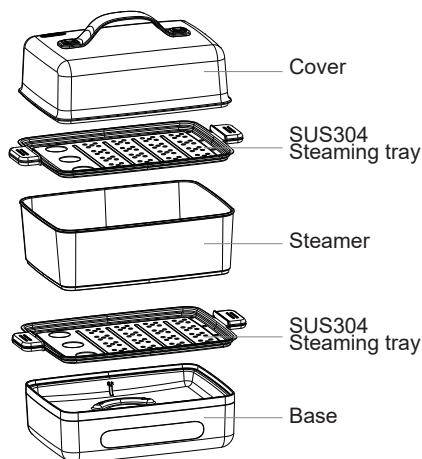

Note : The pictures are for reference only, assemblies maybe different from the picture.

PANEL INSTRUCTION



Operating Instructions & Reservation function

1. After connecting to the power supply, press the “Function/Cancel” button to select the desired function. The corresponding indicator light will turn on, and the preset working time will be displayed.
2. Once the function is selected and the indicator light and display are flashing, press the “+” or “-” buttons to adjust the working time as needed.
3. While the indicator light and display are flashing, press the “Reservation” button to enter reservation mode. The display will show the default reservation time, which can be adjusted using the “+” or “-” buttons.
4. You may also set the reservation time first and then select the function. After both are set, the system will enter reservation mode within 5 seconds. Once the reservation time ends, the selected function will start automatically.

Note:

If the reservation time is set but no function is selected, the reservation indicator will flash for a few seconds and then the unit will shut down automatically. The display will show “OFF”.

Cooking Time Reference Table

1. **Manual Mode**

Default Time: 0:20

Adjustable Range: 0:10 to 0:40

Heating stops after completion; display shows "OFF".

2. **Grains**

Default Time: 0:35

Adjustable Range: 0:25 to 0:45

Automatically switches to warming mode after completion; display shows "_____".

3. **Steamed Buns**

Default Time: 0:20

Adjustable Range: 0:15 to 0:30

Automatically switches to warming mode after completion; display shows "_____".

4. **Boiled Eggs**

Default Time: 0:20

Adjustable Range: 0:10 to 0:30

Heating stops after completion; display shows "OFF".

5. **Steamed Meat**

Default Time: 0:30

Adjustable Range: 0:25 to 0:45

Automatically switches to warming mode after completion; display shows "_____".

Note: If there is no water inside the unit, the warming function will not operate. After warming ends, the display will show "OFF".

Reference Cooking Time Of Each Function

Function Selection	Cooking Ingredients	Water Required	Time Reference (Mins)
Manual	Manual	3.5 Full Cup	20
Grains	Sweet Potato	3.5 Full Cup	35
	Corn	3.5 Full Cup	25
Steamed Buns	Steamed Bun	2.5 Full Cup	20
Boiled Eggs	Whole Egg	2.5 Full Cup	20
Steamed Meat	Steamed Fish	2.5 Full Cup	20
	Steamed Meat	2.5 Full Cup	30

Tips:

1. The above time is the test data of laboratory only for reference, and the time can be adjusted according to the actual demand.
2. Do not add water beyond the maximum water mark.
3. When using the Grain function, please slice the food. It is recommended that the thickness of the slice should not exceed 3cm. Do not stack the ingredients after slicing.

Maintenance

1. After use, please unplug the power cord from the socket immediately to ensure safety.
2. Racks, Steamer, and Lid can be cleaned with dishwashing liquid and a sponge.
3. Do not use steel wool or hard brushes to avoid scratching the surface.
4. Do not immerse the entire machine in water. The exterior of the main unit should only be wiped with a damp cloth. Do not rinse with water to prevent electric shock or malfunction.
5. If the product will not be used for a long time, clean it thoroughly and store it in its original packaging. Keep it in a well-ventilated and dry place to prevent moisture damage.
6. After multiple uses, scale may form on the heating plate (appears as black or gray residue). You can remove it by boiling water with white vinegar. This helps maintain heating efficiency and prevents extended cooking times.

FREQUENTLY ASKED QUESTION

1. There has no display and the product cannot be used normally:
 - Whether there is a power shortage
 - Whether the power plug is plug-in
 - Whether the power socket is turned off
 - The power cord is install at the product, whether well connected to the main body.
2. The food is not well cooked:
 - Whether the stewing time is too short

SPECIFICATIONS

Model No.: GFS2DB-V3

Mains Voltage : 220-240V~

Frequency: 50/60Hz

Power: 350W

Capacity: 2.5 liters Max.

Product Dimension: 260(W)x228(H)x154(D)mm

***The final product specification may be varied according to a different lot of material and actual input voltage power of the usage area.**

安全指引

1. 使用前請詳細閱讀操作指引，以避免因不當使用造成損壞或危險。
2. 8歲以下兒童、傷健人士、精神及感官受到影響者，以及缺乏操作常識和經驗者，不適宜獨立操作本產品。如需操作，需有相關人士從旁指引並對其行為安全負責。
3. 如本產品出現問題，請聯絡代理商或合資格人士處理，切勿自行維修，以免發生危險。
4. 請依照產品上的規格表資料正確連接電源。
5. 本產品僅適用於家居室內操作，不適用於商業用途，亦不可在高濕度空間內使用。
6. 使用前請確保插座接地有效，並確認輸入電壓為 220-240V~ 50/60Hz。
7. 如電源線損壞，請聯絡維修部安排更換。
8. 操作按鍵時請勿用力過猛，以防損壞。
9. 使用過程中如遇問題，請先拔除電源插頭；切勿以濕手插拔插頭，以免觸電。
10. 請勿以尖銳物品拉扯、壓迫或懸掛電線，並應遠離熱源與濕源。
11. 請勿將金屬或其他異物插入散熱孔或縫隙中，以免損壞電路。
12. 請勿將產品放置於熱源表面或附近，如烤箱、烘爐等。
13. 禁止在不平或傾斜的桌面上使用本產品，以免傾倒造成傷害或火災。
14. 請勿在地毯、塑膠凳等不耐熱表面上使用，亦不可將易受蒸氣損壞的物品放置於產品上方。
15. 本產品不適合兒童、精神病患者或缺乏經驗者使用或玩耍。
16. 使用過程中鍋身會變熱，屬正常現象。倒水時請使用提手，切勿直接接觸高溫表面，以免燙傷。
17. 若發生乾燒情況，請待冷卻後加水或拔除電源，切勿觸摸發熱體。
18. 請保持發熱盤表面清潔，使用一段時間後應清理污垢。
19. 使用時蒸氣會從蒸氣口噴出，請小心避免燙傷。
20. 清洗時請勿讓液體流入產品內部，亦不可將電源線、插頭或整機浸入液體中，以免發生危險。

21. 本產品內用於加熱的 PTC 元件不可與食物直接接觸。
22. 本產品具有熱保護功能, 若水乾後工作時間未結束, 數碼管會顯示「E00」警報, 加水後可恢復正常使用。

產品內容

注意! 此產品只適合家庭用途。

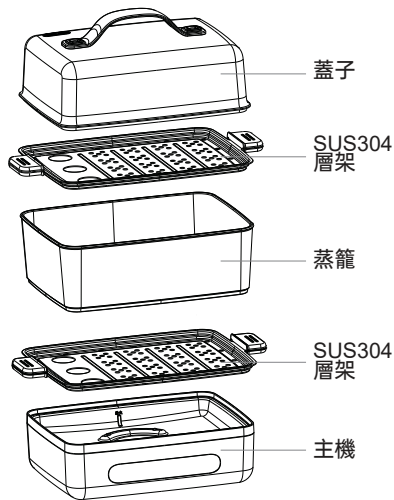

注意: 產品圖片與實物略有不同時, 請以實物為準。

控制面板

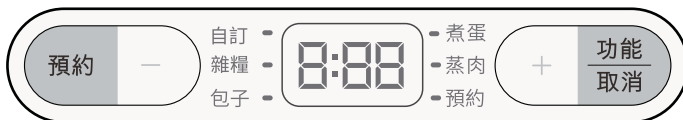

使用方法

1. 接通電源後，按「功能／取消」鍵選擇所需功能，對應的指示燈會亮起，並顯示預設的工作時間。
2. 選擇功能後，當指示燈及顯示屏閃爍時，可按「+」或「-」鍵調整所需的工作時間。
3. 選擇功能後，指示燈及顯示屏閃爍時可按下「預約」鍵進入預約模式，顯示屏將顯示預設的預約時間，可透過「+」或「-」鍵進行調整。
4. 「預約」功能亦可先設定預約時間再選擇功能。當預約時間及功能設定完成後，系統會在 5 秒內進入預約工作模式，並於預約時間結束後自動啟動所選功能。

注意：

若設定了預約時間但未選擇功能，預約指示燈將閃爍數秒後自動關機，顯示屏將顯示「OFF」。

各功能烹飪時間參考表

1. 自訂

預設時間：0:20

可調時間範圍：0:10 至 0:40

完成後停止加熱，顯示屏顯示「OFF」。

2. 雜糧

預設時間：0:35

可調時間範圍：0:25 至 0:45

完成後自動進入保溫模式，顯示屏顯示「_____」。

3. 包子

預設時間：0:20

可調時間範圍：0:15 至 0:30

完成後自動進入保溫模式，顯示屏顯示「_____」。

4. 煮蛋

預設時間：0:20

可調時間範圍：0:10 至 0:30

完成後停止加熱，顯示屏顯示「OFF」。

5. 蒸肉

預設時間：0:30

可調時間範圍：0:25 至 0:45

完成後自動進入保溫模式，顯示屏顯示「_____」。

注意：當機體內無水時，保溫功能將無法運行。保溫結束後，顯示屏將顯示「OFF」。

功能使用參考：

功能選擇	烹飪食材	機體加水量	時間參考 (分鐘)
自訂	自訂	3.5 滿杯	20
雜糧	蒸番薯	3.5 滿杯	35
	蒸粟米	3.5 滿杯	25
包子	蒸包	2.5 滿杯	20
煮蛋	蒸全蛋	2.5 滿杯	20
蒸肉	蒸魚	2.5 滿杯	20
	蒸肉	2.5 滿杯	30

溫馨提示：

1. 以上為參考資料，使用時根據食材分量及實際需求調節時間。
2. 加水請勿超出最大水位刻度線。
3. 使用雜糧功能時，請把食材切片，建議切片厚度不超過3cm。注意切片後食材不要堆疊放置。

保養和維護

1. 使用完畢後，請立即將電源插頭從插座拔出，確保安全。
2. 層架、蒸籠與上蓋可使用洗潔精與海綿清洗。請勿使用鋼絲球或硬質刷具，以免刮傷表面。
3. 切勿將整台機器浸入水中。主機外殼僅可用濕毛巾擦拭，不可直接用水沖洗，以避免漏電或故障。
4. 若長時間不使用，請先清潔乾淨，並放入原包裝箱中。存放於通風乾燥處，避免受潮影響日後使用。
5. 多次使用後，發熱板表面可能會產生水垢（表現為發黑或灰色物質）。可加入白醋煮水以去除水垢，避免影響加熱效率與延長烹飪時間。

常見問題

1. 顯示屏不亮：
 - a. 是否停電？
 - b. 電源線是否插入插座中？
 - c. 電源插座是否處於關閉狀態？
 - d. 本產品是否選擇該功能。
2. 食物煮得不夠熟：
 - 蒸煮時間是否太短

備註：

經以上現象分析後仍無法排除故障，請與本公司維修點或經銷商聯繫，嚴禁非專業人員對本機自行拆裝。

產品規格

型號：GFS2DB-V3

電壓：220-240V ~

頻率：50/60Hz

功率：350W

容量：2.5 公升（最大）

產品尺寸: 260(W)x228(H)x154(D)mm

*相關產品的規格，可能會因配件批次或實際使用地區的電壓差異而有所不同。

請記錄下列產品資料

型號 Model No.:

機身編號 Serial No.:

經銷商名稱 Dealer:

購買日期 Date of Purchase:

單據編號 Invoice No.:

本產品不斷改進中，如功能有所更改，恕不另行通知
如有疑問，請與客戶服務中心聯絡。不便之處，敬請原諒。

The product specifications may be changed without prior notice.
Please contact customer service for details if necessary.

說明書內容以英文版本為準

If there is any inconsistency or ambiguity
between the English version and the Chinese version,
the English version shall prevail.

保養登記
Warranty Registration



於網上登記新產品保養
Register your product online
www.dchtoolbox.com

小電維修服務 - 自攜點
Repair Service - Collection Points

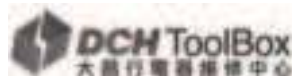

客戶服務中心 DCH ToolBox Customer Service Centre
香港九龍灣啟祥道20號大昌行集團大廈4樓
4/F, DCH Building, 20 Kai Cheung Road, Kowloon Bay, Hong Kong

客戶服務熱線 Customer Service Hotline: (852) 8210 8210
電郵地址 E-mail: 8210service@gilman-group.com

www.gemini-living.com