



GIMA

PROFESSIONAL MEDICAL PRODUCTS

PEDALIERA ELETTRICA CON DISPLAY - NERA
ELECTRIC PEDAL EXERCISER WITH DISPLAY - BLACK
MINI-VÉLO ÉLECTRIQUE AVEC ÉCRÁN - NOIR
EJERCITADOR CON PEDAL ELÉCTRICO CON PANTALLA - NEGRO
EXERCÍCIO DE PEDAL ELÉTRICO COM DISPLAY - PRETO
ΗΛΕΚΤΡΙΚΟ ΠΕΔΑΛ ΑΣΚΗΣΗ ΜΕ ΟΘΟΝΗ - ΜΑΥΡΟ
ELEKTRYCZNY ĆWICZNIK PEDAŁOWY Z WYŚWIETLACZEM - CZARNY
PEDALA ELECTRICA CU DISPLAY - NEGRU
ELEKTRISK PEDALTRÄNARE MED DISPLAY - SVART

Manuale utente - User manual - Notice d'utilisation - Manual del usuario - Guia para utilização - Gebrauchs- und instandhaltungsanleitung - Εγχειρίδιο χρήσης - Lietotāja rokasgrāmata - Používateľská príručka - Uporabniški priročnik - Användarmanual

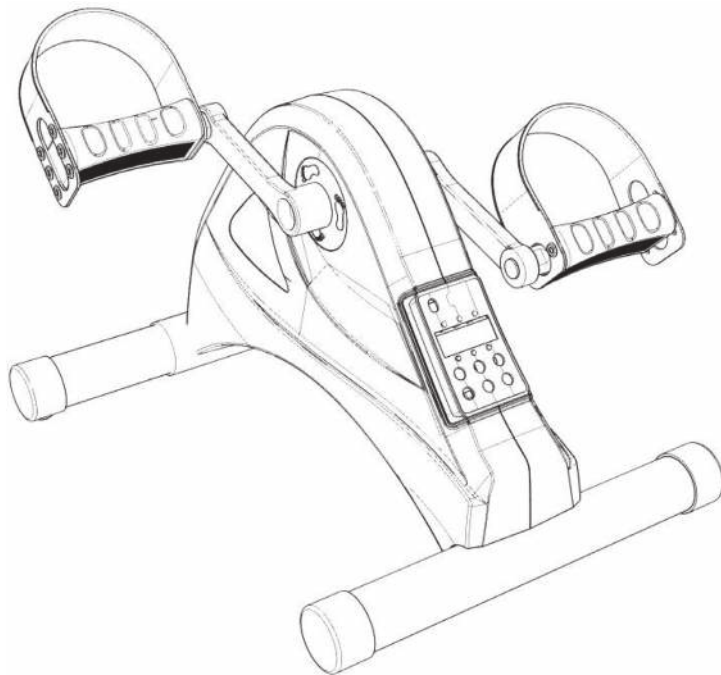

REF TD001-P8 (GIMA 43153)

Fabbricato da/Manufactured by/Fabriqu  par/Fabricado por/Hergestellt von/
Tillverkad av/Raots/ Proizvajalec/Κατασκευασμένο από/Produs de/Vyr ba
Zhejiang Todo Hardware Manufacture co., Ltd
31st Floor, Jinmao Building, CBD center, Yongkang, Zhejiang, China
Made in China

Importato da/Imported by/Import  par/Importado por/Eingef hrt von
Importerad av/Import ja/Uvozil/Eισαγωγή από/Importat de/Dov zal
Gima S.p.A. - Via Marconi, 1 - 20060 Gessate (MI) Italy
gima@gimaitaly.com - export@gimaitaly.com
www.gimaitaly.com



**IMPORTANT SAFETY WARNINGS**

1. Read all the introductions in this manual before using the product. Follow all warnings and operating introductions prior to use.
2. Do not use it alone or in a place where children and pets can touch it. Under no circumstances should this appliance be used as a toy.
3. The owner is responsible for ensuring that all users use this product safely.
4. This product is intended for domestic users only.
5. Do not store this product in a damp place.
6. DO not wear loose or baggy clothing, since it may get caught in the machine. Take off all jewelry.
7. If you feel any pain, or become dizzy while exercising, stop immediately, rest and consult a physician.
8. Please be sure that the holes in the wall socket outlet must match the pin configuration for the plug on the machine. If this is not the case, please consult your supplier.
9. This unit has been designed for home use only.

PRECAUTIONS

Consult your doctor before using this product or any other fitness product. Especially if you are in the following conditions, such as cancer patients, convalescence after surgery, history of heart problems, fractured bones, pregnancy and so on.

PARTS LIST

- A 1 Main body
- B 2 Pedals
- C 1 Power plug
- D 2 Stabilizers
- E 1 Remote control
- F 4 Bolts
- G 1 Screwdriver
- H 1 Spanner

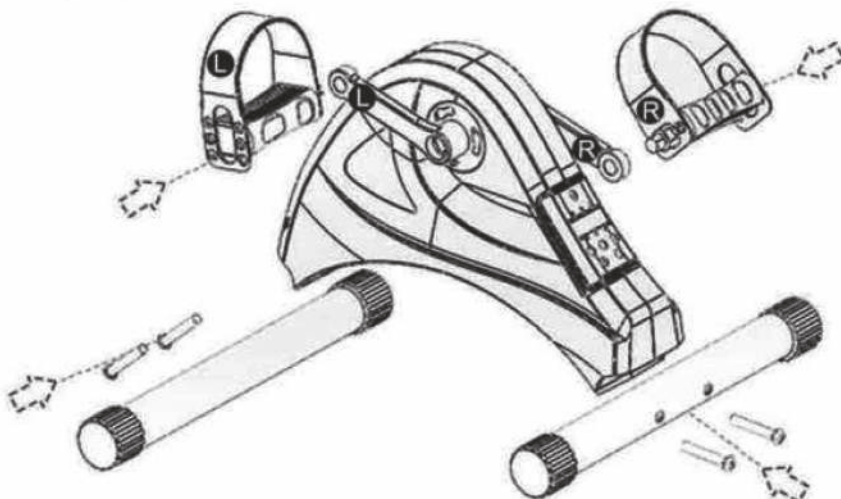
ASSEMBLY

It will take you two minutes to complete all the assembly.

1. Take the Stabilizers(D) and fix it as show on the picture, just use the screwdriver to tighten the bolts.
2. Right and left refer to the position that the user adopts when to do the exercises. Insert the right-hand pedal(B) onto the right hand crank, insert the left-hand pedal (B) onto the left-hand crank.

Use the spanner to assemble pedals. Right pedal towards clockwise, left pedal towards counterclockwise.

CONNECTING POWER



INSTRUCTIONS OF DISPLAY PANEL AND REMOTE CONTROL

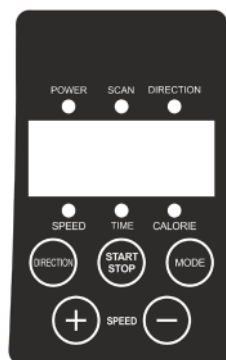

Display Panel:

1. **SCAN:** The ordinal data display speed, time, calories.
2. **START/STOP:** Start or stop the machine.
3. **DIRECTION:** Change the direction of pedal movement.
4. **MODE:** Press button to select automatic modes or manual mode.
5. **SPEED + -:** When machine is on manual mode, you can press button to adjust the speed.

Connect the unit to a socket.

OPERATION

1. Plug the adaptor plug to the direct current and press the red button which is nearby the connector.
2. On the stop status, press the **MODE** button to select different modes, there are automatic modes and manual mode. On the manual mode, screen flashes **-HA-**. On the automatic modes, screen shows **P1, P2, P3**.
3. Press the **MODE** button, screen flashes **-HA-**, then press the **START** button, the unit will work at the speed level 1, you can use the **SPEED** button to adjust the speed from 1 to 6 levels.
4. Press the **STOP** button, the unit will stop working.
5. Default working time are 30 minutes, device will automatically turn off when the working time is over 30 mins.
6. Press the **DIRECTION** button, the machine will change the direction of rotation of the pedals.

NOTE: Button introductions of remote control is as same as the panel. User need to insert 2 AAA batteries.

EXERCISING

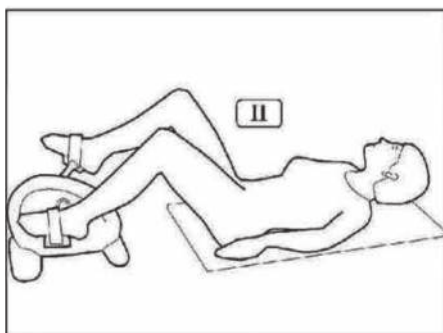
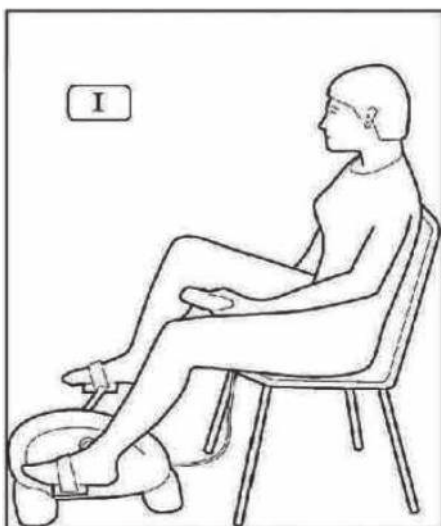

LEG EXERCISING WHEN SITTING

1. Use a stable and sturdy chair.
2. Be sure to place the machine at a comfortable distance from the chair.
3. Sit and place your feet on the pedals.
4. Use the remote control to operate this machine and start your exercising.

LEG EXERCISING WHEN LYING

When lying down, make sure that your lower back(lumbar region) is supported when using this product. We recommend placing a small cushion below the lumbar region and under your head.

ARM EXERCISING

1. Be sure to place the machine at a comfortable distance from the chair.
2. Sit and place your arm on the pedals.
3. Use the remote control or control panel to operate this machine and start your exercising.

**TECHNICAL SPECIFICATION**

Rated Voltage	24V
Power	80 W
G.W./N.W.	4,8/4,2 kg
Default Working Time	30 minuti
Max. Bearing Weight	40 kg
Packing Size	40,2 x 32 x 14,5 cm

 **Disposal:** *The product must not be disposed of along with other domestic waste. The users must dispose of this equipment by bringing it to a specific recycling point for electric and electronic equipment.*

GIMA WARRANTY TERMS

The Gima 12-month standard B2B warranty applies.