



Operating Instructions

10L Dehumidifier



Model: GSD185

General Care and Safety Guide

YOUR SAFETY IS IMPORTANT TO US. PLEASE ENSURE YOU TAKE NOTE OF THE INSTRUCTIONS AND WARNINGS OUTLINED IN THIS MANUAL.

CAUTION: In order to avoid a hazard due to inadvertent resetting of the thermal cut-out, this appliance must not be supplied through an external switching device, such as a timer, or connected to a circuit that is regularly switched on and off by the utility.

- This appliance is not intended for use by persons (including children) with reduced physical, sensory or mental capabilities or lack of experience and knowledge, unless they are supervised or have been given instruction concerning the use of the appliance by a person responsible for their safety.
- Children should be supervised to ensure that they do not play with the appliance.
- If the supply cord is damaged, it must be replaced by the manufacturer, its service agent or similarly qualified persons in order to avoid a hazard.

WARNING: You must not cover this dehumidifier. Covering this dehumidifier presents fire risk and will activate the safety fuse; permanently disabling the unit.

WARNING: Do not use this dehumidifier in small rooms when they are occupied by persons not capable of leaving the room on their own, unless constant supervision is provided.

WARNING: To reduce the risk of fire, keep textiles, curtains, or any flammable material a minimum distance of 1 metre from the air outlet.

- Use only the voltage specified on the rating label of the appliance.
- The dehumidifier must not be located immediately below a socket outlet.
- Keep all objects at least 1 metre from the front, sides and rear of the appliance.
- This appliance is intended for household use only and not for commercial or industrial use.
- Indoor use only.
- Use this appliance only as described in this manual. Any other use is not recommended by the manufacturer and may cause fire, electric shock or injury.
- Do not use the dehumidifier if it has been dropped or damaged.
- The common cause of overheating is deposits of dust or fluff in the appliance. Ensure these deposits are removed regularly by unplugging the appliance and vacuum cleaning the air vents and grills.
- Always unplug appliance when not in use.
- When the appliance has been unpacked, check it for transport damage and ensure all parts have been delivered. If parts are missing or the appliance has been damaged, contact the Customer Services Team.
- Do not use if there are visible signs of damage to the dehumidifier.

General Care and Safety Guide

- **Never use the appliance to dry clothes.**
- Do not connect the appliance to mains supply until completely assembled and adjusted.
- Ensure hands are dry before handling the plug or main unit.
- Ensure dehumidifier is on a flat, stable, heat-resistant surface.
- Do not operate with cord set coiled up as a heat build up is likely, which could be sufficient to become a hazard.
- Carry out regular checks of the supply cord to ensure no damage is evident
- Do not operate this appliance with a damaged cord, plug or after the appliance malfunctions or has been dropped or damaged in any manner. Return to a qualified electrical person for examination, electrical service or repair.
- Do not twist, kink or wrap the cord around the appliance, as this may cause the insulation to weaken and split. Always ensure that all cord has been removed from any cord storage area and is unrolled before use.
- It is recommended that this dehumidifier is plugged directly into the wall socket. Power boards are not rated to supply power to high wattage appliances.
- A correctly specified, undamaged extension cord may be used with this dehumidifier provided it is used in a safe manner.
- Do not remove plug from power socket until the appliance has been switched off.
- Do not remove plug from power socket by pulling cord; always grip plug.
- Do not place cord under carpet or cover with rugs or furniture. Arrange the cord so it cannot be tripped over.
- Don't place appliance on bedding or on thick & long carpet where the openings may get blocked.
- Switch off and use handle provided when moving
- Do not place appliance close to radiant heat source.
- Do not insert or allow foreign objects to enter any ventilation or exhaust opening, as this may cause an electric shock, fire or damage to the appliance.
- Do not sit on the appliance.
- Do not use abrasive cleaning products on this appliance. Clean with a damp cloth (not wet) rinsed in hot soapy water only. Always remove plug from the mains supply before cleaning.
- Do not operate in areas where petrol, paint or other flammable liquids are used or stored.
- Do not use this appliance in the immediate surrounds of a bath, a shower, or a swimming pool or other liquids.
- The appliance must not be immersed in any liquids.
- There are no user serviceable parts installed in the unit.
- Do not place the unit in wardrobes or other enclosed spaces as this may cause fire hazards.
- This unit is not supposed to be used in or around locations where foodstuffs, works of art or delicate articles of science, etc. are stored.
- If your appliance does not work, or is not working properly, contact the place of purchase or the Customer Services Team.

General Care and Safety Guide

Goldair 

DO NOT COVER

MODEL: GSD185
SUPPLY: 220-240VAC 50Hz
RATED POWER: 205W (35°C/60%RH)
MOISTURE REMOVAL: 10L/day (30°C/60%RH)
REFRIGERANT: R290 / 45g
HIGH PRESSURE: 1.0MPa
LOW PRESSURE: 0.6MPa
MAX PERMITTED PRESSURE: 3.0MPa
APPROVAL: TUV024726EA
MADE IN CHINA

 GC PASSED
POM-WWYY

CUSTOMER SUPPORT
NEW ZEALAND PH: 0800 232 633



Appliance is filled with flammable gas R290.



Before using the appliance, read the manual.



Before installing the appliance, read the installation manual.



Any repairs required, contact the nearest authorised Service Centre and strictly follow the manufacturer's instruction only.



Caution, risk of fire

WARNING: Appliance shall be installed, operated and stored in a room with a floor area larger than 4m².

Do not use any means to accelerate the defrosting process or to clean, other than those recommended by the manufacturer.

The appliance shall be stored in a room without continuously operating ignition sources. (example: open flames, an operating gas appliance or an operating electric heater).

Do not pierce or burn.

Be aware that refrigerants do not have any odour.

Components

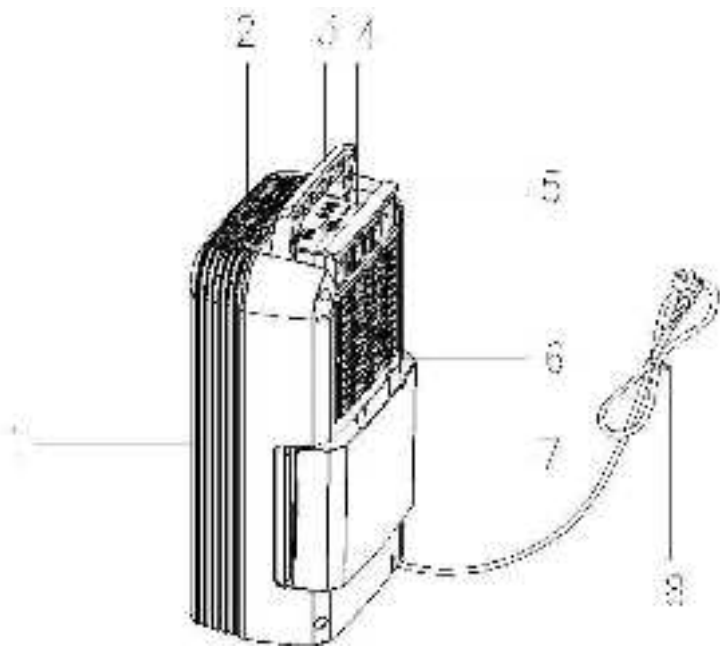

1. Front Panel
2. Air Outlet
3. Handle
4. Control Panel
5. Inlet Grill & Air Filter
6. Back Panel
7. Water Tank
8. Power supply cord

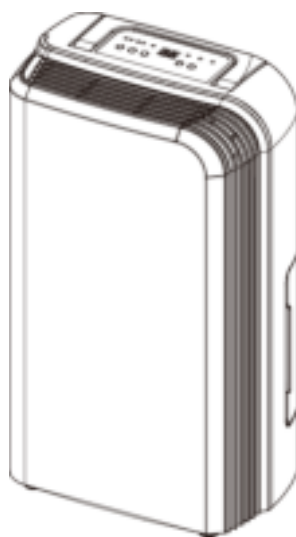

Operating Your Dehumidifier

Always choose a safe location for the dehumidifier, keeping in mind the safety precautions outlined. Ensure all packaging has been removed from the unit before use. Please follow the below instructions.

WARNING: In order to avoid overheating or fire, do not cover the dehumidifier.

WARNING: Keep all objects at least 1 metre from the front and 150mm from the sides of the appliance.

WARNING: Do not use this dehumidifier with a programmer, separate timer, remote-control system or any other device that switches the dehumidifier on automatically, since a fire risk exists if the dehumidifier is covered or positioned incorrectly.

Ensure dehumidifier is on a flat, stable, heat-resistant surface.

Once the dehumidifier is in a safe operating position and all switches are in the off position, insert the power plug into the mains outlet.

CAUTION: Ensure the power cord is not tight because if pulled it may partially pull the plug from the socket. A partially inserted plug will overheat the plug and socket and could result in fire.

Operating Your Dehumidifier

CONTROL PANEL

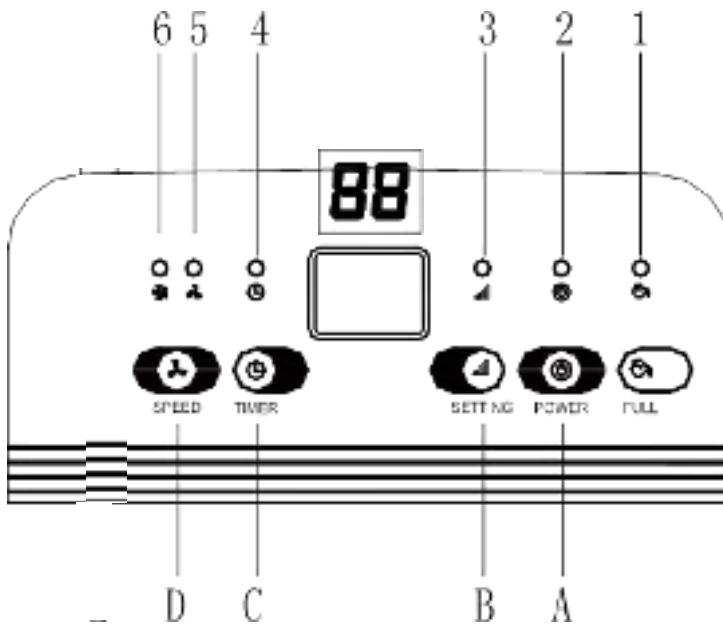

LED INDICATOR LIGHTS

- 1.WATER FULL
- 2.POWER
- 3.SETTING
- 4.TIMER
- 5.LOW FAN SPEED
- 6.HIGH FAN SPEED

PUSH BUTTONS

- A. Power Button
- B. Adjustable Humidity Button
- C. Timer Button
- D. Fan Speed Button

DIGITAL DISPLAY

The indicator features 4 functions:

Indicates the room humidity level – in normal operating mode

Indicates the humidity that you have selected - when setting the humidity

Indicates the hours - when programming the time for the unit to turn on and off

Displays power setting - when the environment humidity is lower than 35%, it will show “LO”, when the environment humidity is higher than 95%, it will show “HI”.

Operating Your Dehumidifier

OPERATING INSTRUCTIONS

Always choose a safe location for the Dehumidifier, keeping in mind the safety precautions outlined. Ensure all packaging has been removed from the unit before use. This appliance requires no installation, it should be used solely as a portable appliance. Leave the appliance to stand for one hour after transport or after the unit has been on its side, before connecting it to the mains supply to let the refrigerant settle.

1. The Power indicator light will illuminate when the unit is plugged in, regardless of whether the unit is operating or not.
2. Press Power button once to start operation. Press it again to stop operation.
3. Press Setting button to set the desired humidity level in the room, humidity can be set from 40% to 80% in 5% increments.

Note: When the environment humidity is lower than the selected humidity by 2%, the compressor will stop. The fan will continue to run to keep sensing the relative humidity.

When the environment humidity is equal to or higher than the selected humidity by 2%, the compressor will restart (once the 3-minute compressor protection time has elapsed).

TIMER

1. Press Timer button to set the timer.
2. Use the Timer button to program the time when the unit automatically turns itself off. Press the button, and it will be change from 00 to 24 in 1 hour increments.
3. The programmed time will be cancelled if the dehumidifier is switched to manual. The programmed time remains unchanged if the machine stops working due to the water tank being full or during defrosting. If you want to cancel the timer programming, press the button and adjust the time to 00.

FAN SPEED

Press Speed button to set the desired fan speed. It can be adjusted between high speed and low speed.

WHEN THE WATER CONTAINER IS FULL

A beep signal will sound 15 times and the tank full indicator light will illuminate. The compressor will stop automatically. This will also stop the dehumidification process. Empty the water container and replace it in the correct position. The Dehumidifier will continue dehumidifying when the compressor automatically restarts after approximately three minutes.

Note: Do not remove the float from the water tank. The water full sensor will no longer be able to detect the water level correctly without the float and water may leak from the water tank.

When replacing the drainage tank, press the tank firmly into place with both hands. If the tank is not positioned properly, the "TANK FULL" sensor will be activated, and the dehumidifier will not operate.

This Dehumidifier is designed to provide an optimum performance. It is not recommended to operate in ambient temperature exceeding 35°C or lower than 5°C.

Ensure all external windows and doors are closed before turning on the unit.

Operating Your Dehumidifier

PERMANENT WATER DRAINAGE

It is possible to connect a drainage tube (not supplied) to the unit for permanent water drainage. If this option is desired, you will need to purchase a suitable tube from your local hardware retailer.

(Nouveau does not hold tubes as spare parts).

Connect the drainage hose to the drain spout. Ensure that the end of the hose is lower than the drain opening, otherwise the water will not drain and flooding may occur.

Also ensure the water tank is in position (in the unit) otherwise the continuous drainage will not operate.

Place the end of the drainage hose in a drainage outlet.

When you no longer wish to use the permanent water drainage, disconnect the drainage tube from the device.

CLEANING AND MAINTENANCE

- Unplug the Dehumidifier from the mains supply before cleaning.
- Ensure that the Dehumidifier has been allowed to cool down completely before cleaning.
- Use a damp cloth (not wet) to wipe the exterior of the Dehumidifier to remove dust and dirt.
- Use a vacuum cleaner to remove dust and fluff from around the grills.
- Never use solutions such as benzene, thinners or polishing agents.
- Ensure the Dehumidifier is dry before plugging back into the mains supply.

Do not attempt to dismantle the Dehumidifier. There are no user serviceable parts. For service or repair, contact an authorised electrical service technician.

THE AIR FILTER

Unplug the Dehumidifier from the mains supply.

Remove the filter. Clean the filter with a vacuum or with water. Dry the filter.

Ensure the filter is completely dry before placing back in the unit.

Never use the Dehumidifier without the air filter.

STORAGE

To store the unit, remove the plug from the socket and empty the water container. Allow the container and the Dehumidifier to dry completely. Clean the air filter. Store the device in a dust-free location, preferably covered with a sheet of plastic.

IMPORTANT: NEVER COVER THIS DEHUMIDIFIER!

TROUBLE SHOOTING

Problem	Cause	Solution
The Dehumidifier will not turn on	The power is not connected	Insert plug into mains power supply and turn unit on
The Dehumidifier is not extracting water	The water tank is full	Remove the water tank and empty water
	The water tank is not in its correct position	Remove water tank and replace it in its correct position
	The air filter is clogged	Clean the air filter as per instructions in user manual
	The temperature or relative humidity in the room is too low	It is normal for the Dehumidifier not to operate in low humidity or low temperatures
The Dehumidifier operates, but reduces the relative humidity in the room by small amounts	The room which the Dehumidifier is operating in is too large	Recommend using a Dehumidifier with a larger capacity
	There are too many sources of humidity	Recommend using a Dehumidifier with a larger capacity
	The room has too much ventilation	Reduce the number of ventilation sources (i.e. close windows, doors, etc.

PROOF OF PURCHASE

To receive warranty retain receipt as proof of purchase.

Goldair[®]

SUPPORT AND TECHNICAL ADVICE

Goldair – New Zealand
 Monday – Friday 8am-5pm
 Phone +64 (0)9 917 4000
 Phone 0800 232 633
 info@cdb.co.nz

Goldair – Australia
 Monday – Friday 8am-5pm
 Phone +61 (0)3 9365 5100
 Phone 1300 465 324
 info@cdbgoldair.com.au



Two Year Warranty

Thank you for purchasing this Goldair product. Your product is warranted against faults and manufacture when used in normal domestic use for a period of **two years**. In non-domestic use Goldair limits the voluntary warranty to **three months**.

Goldair undertake to repair or replace this product at no charge if found to be defective due to a manufacturing fault during the warranty period.

This warranty excludes damage caused by misuse, neglect, shipping accident, incorrect installation, or work carried out by anyone other than a qualified electrical service technician.

PLEASE KEEP YOUR RECEIPT AS THIS WILL HELP VERIFY YOUR WARRANTY.

The benefits given to you by this warranty are in addition to other rights and remedies available to you under law in relation to the goods or services to which this warranty relates.

In Australia, our goods come with guarantees that cannot be excluded under the Australian Consumer Law. You are entitled to a replacement or refund for a major failure and compensation for any other reasonably foreseeable loss or damage. You are also entitled to have the goods repaired or replaced if the goods fail to be of acceptable quality and the failure does not amount to a major failure.

In New Zealand this warranty is additional to the conditions and guarantees of the Consumers Guarantee Act (1993).

Goldair – New Zealand

CDB Goldair
PO Box 100-707
N.S.M.C
Auckland

Phone +64 (0)9 917 4000
Phone 0800 232 633

www.goldair.co.nz

Goldair – Australia

CDB Goldair Australia Pty
PO Box 574
South Morang
Victoria, 3752

Phone +61 (0)3 9365 5100
Phone 1300 GOLDAIR (1300 465 324)

www.goldair.com.au

Goldair Two Year Warranty (IMPORTANT: Please complete and retain this warranty card)

Name

Address

Place Of Purchase

Date Of Purchase

Name Of Product

Model Number

Attach a copy of the purchase receipt to this warranty card

Due to continual design improvements, the product illustrated in this User Manual may differ slightly from the actual product.

Goldair™

select



CDB  **Goldair**

New Zealand
PO Box 100707,
North Shore Mail Centre,
Auckland, 0745
www.goldair.co.nz

Australia
PO Box 574,
South Morang,
Victoria, 3752
www.goldair.com.au