

# GOLDAIR

## Operating Instructions

### 2.9kW Portable Air Conditioner



Item: GCPAC295

# General Care and Safety Guide

**Thank you for choosing this Goldair product. This Goldair appliance has been designed and manufactured to high standards of engineering and with proper use and care, as described in this leaflet, will give you years of useful service. Please read these instructions carefully and keep them for future reference.**





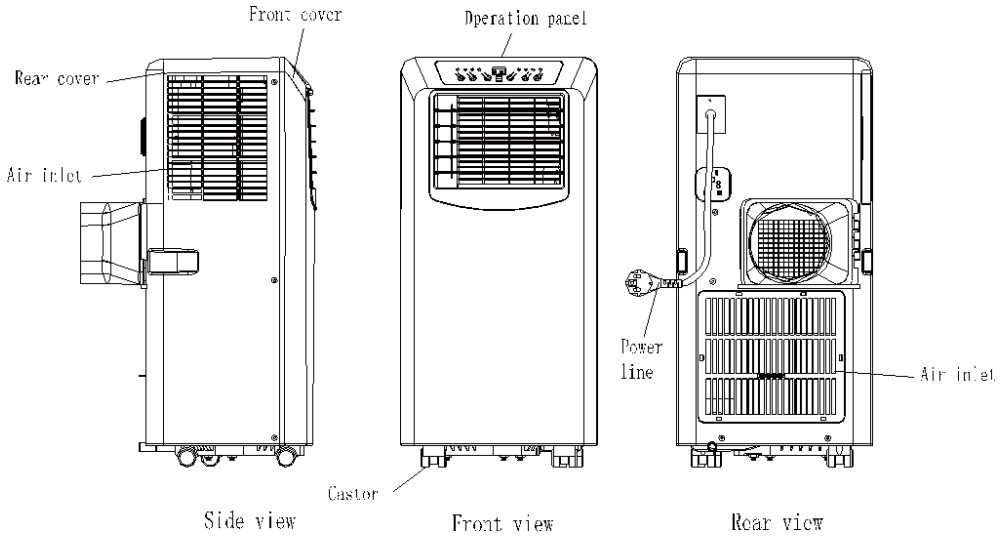

1. Use only the voltage specified on the rating plate of the appliance.
2. Keep all objects at least 1 Metre from the front, sides and rear of the appliance
3. This appliance is intended for household use only and not for commercial or industrial use.
4. Use this appliance only as described in this manual. Any other use is not recommended by the manufacturer and may cause fire, electric shock or injury.
5. The common cause of overheating is deposits of dust or fluff in the appliance. Ensure these deposits are removed regularly by unplugging the appliance and vacuum cleaning the air vents and grills.
6. Always unplug appliance when not in use.
7. When the appliance has been unpacked, check it for transport damage and ensure all parts have been delivered. If parts are missing or the appliance has been damaged, contact the CDB Customer Services Team.
8. If your appliance does not work, or is not working properly, contact the place of purchase. Repair work on the appliance by unqualified persons can cause serious risk to the user.
9. Ensure hands are dry before handling the plug or the main unit.
10. Carry out regular checks of the supply cord to ensure no damage is evident.
11. Children should be supervised to ensure that they do not play with the appliance.
12. Ensure that the cord is fully extended (not coiled) while in use.
13. Avoid contact with the moving parts. Keep hands, hair, clothing, away from blade of the fan during operation to reduce the risk of injury to person and/or damage to the unit.
14. Switch off and use handles provided when moving.
15. This appliance is not intended for use by persons (including children) with reduced physical, sensory or mental capabilities or lack of experience and knowledge, unless they are supervised or have been given instruction concerning the use of the fan by a person responsible for their safety.
16. It is recommended that this appliance is plugged directly into the wall socket.
17. A correctly specified, undamaged extension cord may be used with this appliance provided it is used in a safe manner.
18. Never place appliance close to radiant heat source.
19. Never operate in areas where petrol, paint or other flammable liquids are used or stored.
20. Never use the appliance to dry clothes.
21. Never insert or allow foreign objects to enter any ventilation or exhaust opening, as this may cause an electric shock, fire or damage to the appliance.
22. Never use abrasive cleaning products on this appliance. Clean with a damp cloth (not wet) rinsed in hot soapy water only. Always remove plug from the mains supply before cleaning.
23. Never connect the appliance to mains supply until completely assembled and adjusted.
24. Never remove plug from power socket until the appliance has been switched off.
25. Never remove plug from power socket by pulling cord – always grip plug.
26. Never twist, kink or wrap the cord around the appliance, as this may cause the insulation to weaken and split. Always ensure that all cord has been removed from any cord storage area and is unrolled before use.
27. Never use this appliance in the immediate surrounds of a bath, a shower, or a swimming pool or other liquids. The appliance must not be immersed in any liquids.
28. Due to the risk of injury, never use this appliance for any purpose other than its intended use. This appliance is intended for use in household and similar applications such as staff kitchen areas in shops, offices and other working environments; farm houses, by clients in hotels, motels, bed and breakfast type environments and other residential type environments
29. Never use this appliance outdoors.
30. Never operate the appliance with a damaged cord or plug, after it malfunctions, or if it has been damaged in any manner. Have the appliance checked and repaired by a qualified electrician if repair is necessary. If the supply cord is damaged, it must be replaced by the manufacturer, its service agent or similarly qualified persons in order to avoid a hazard.
31. Never place the unit in wardrobes or other enclosed spaces as this may cause fire hazards.

## TECHNICAL SPECIFICATION

Item:	GCPAC295
Supply:	220-240VAC 50Hz
Wattage:	1110W

# Components



Part	Description	Quantity
	Main Air Conditioner Unit	1
	Hot-Air exhaust hose	1
	Hose Connector (Window end)	1
	Hose Connector (Air Conditioner end)	1
	Window Kit	1
	Remoter Controller	1

# Mounting Position Instructions

**NOTE:** The air-conditioner should be installed on a flat surface with at least 30cm clearance all around, including from the top of the unit as it is important that the air outlet is not blocked. Power supply must be nearby.

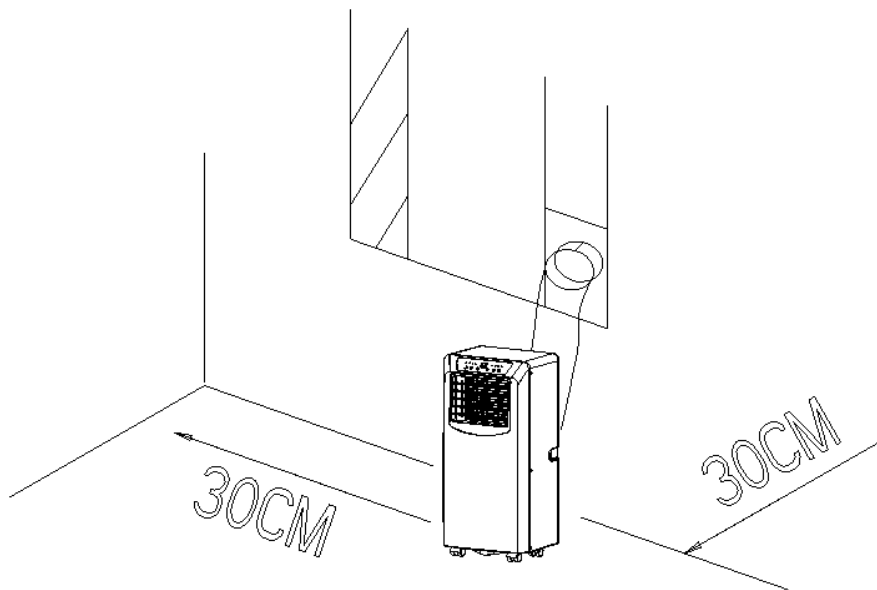

# Mounting Position Instructions

Always choose a safe location for the Air Conditioner, keeping in mind the safety precautions outlined. Ensure all packaging has been removed from the unit before use.

## Step 1.

Twist both ends of the exhaust hose into the square fixing clip and the flat fixing clip. Insert the square fixing clip into openings at back of the air conditioner.

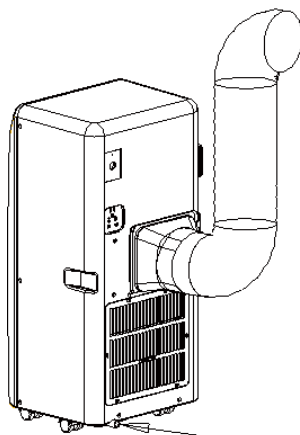

drain hose

## Step 2.

As shown below, install the exhaust hose, so that the exhaust air is removed from the room. You may require a glazier to cut a hole in your window pane to fit the exhaust hose fixing clip.

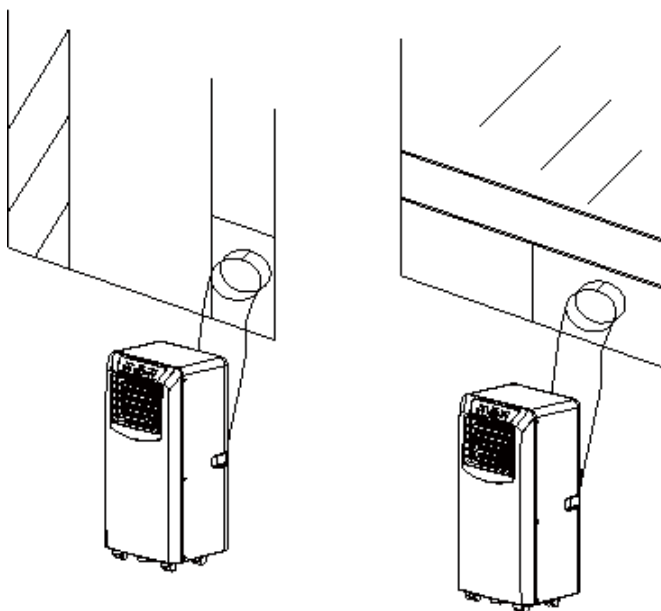

# Control Panel and Remote Control

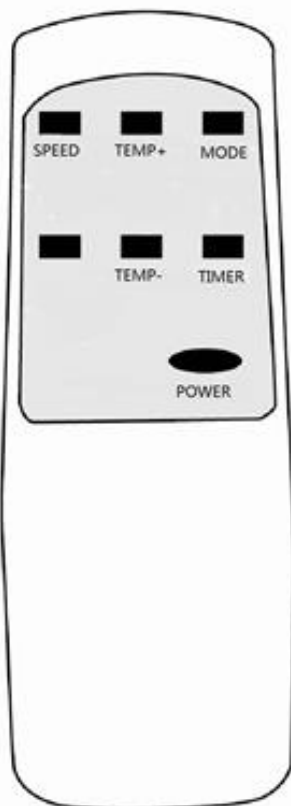
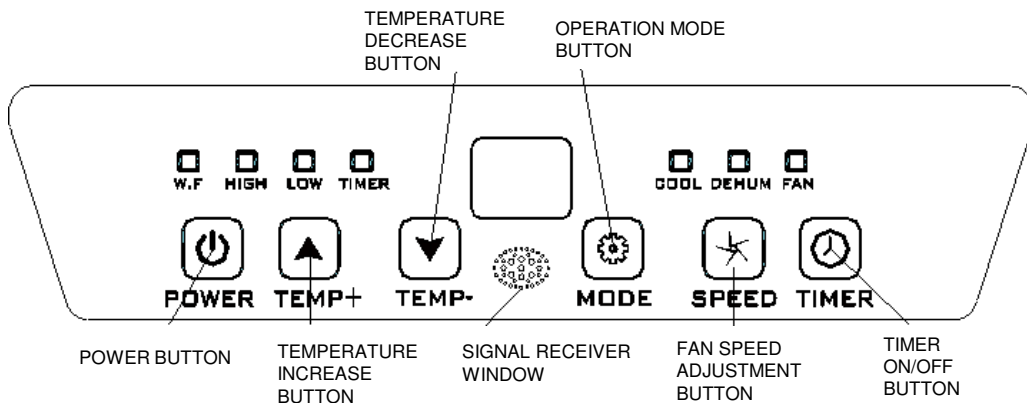

# Operating your Air Conditioner

**This Portable Air Conditioner is designed to be operated in cooling mode, or dehumidifying mode. When switching between these two functions keep an interval of at least 3 minutes between each ON/OFF.**

Allow the refrigerant to settle by leaving the appliance to stand for one hour after transport or after the unit has been on its side before connecting it to the mains supply.

Do not use this Air Conditioner with a programmer, remote-control system, separate timer or any other device that switches the Air Conditioner on automatically.

## COOLING OPERATION

Ensure that the exhaust hose is positioned correctly. Plug into power supply. To turn the Air Conditioner on, press the POWER button. The control panel will illuminate and turn off after 15 seconds. The display will show the working mode and status of unit. Press the "MODE" button until the "COOL" icon appears. Press the "TEMP +" or "TEMP -" button to select desired room temperature (16°C - 31°C). Press the "FAN SPEED" button to select wind speed. Press the "POWER" button again, the unit will stop.

## CARE AND CLEANING

Do not attempt to dismantle the Air Conditioner. There are no user serviceable parts. For service or repair, contact an authorised electrical service technician.

### To clean the air filter:

Open the air inlet grill and remove the filter. Wash the air filter with a neutral detergent in lukewarm (40°C) water and allow it to dry thoroughly in the shade before placing back into the unit.

## DEHUMIDIFY OPERATION

Press the "MODE" button until the "DEHUMIDIFY" icon appears.

The unit will automatically set the selected temperature to current room temperature, minus 2°C (16°C - 31°C).

The unit will automatically set the fan motor to LOW wind speed.

Press the "POWER" button again, the unit will stop.

## NEVER USE UNIT WITHOUT THE AIR FILTER.

The exterior may be cleaned with a soft, dry cloth. If the device is extremely dirty wipe the device with a slightly damp (not wet) cloth. Never spray the device with water.

DO NOT immerse the unit in water and never allow water to enter the motor housing.

DO NOT use harsh chemicals to clean the unit.

## FAN OPERATION

Press the "Mode" button till the "Fan" icon appears.

Press the "Fan Speed" button to select the speed.

## IMPORTANT! NEVER COVER THIS AIR CONDITIONER

## TIMER OPERATION

**To set the unit to turn on:** (when the air-conditioner is OFF), press the "Timer" button and select a desired ON time through the temperature and time setting buttons.

"Preset ON Time" is displayed on the operation panel. ON time can be regulated at any time in 0-24 hours.

**To set the unit to turn off:** (when the air-conditioner is ON), press "Timer" button and select a desired OFF time through the temperature and time setting buttons.

"Preset OFF Time" is displayed on the operation panel.

OFF time can be regulated at any time in 0-24 hours.

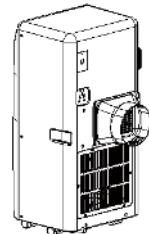
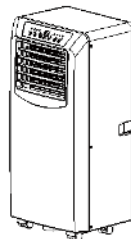

## STORAGE

To store the unit, remove the plug from the socket. Remove the rubber plug from the drainage hole at the bottom of unit, and connect a drain hose to the lower fixing clip. All the water in the water tank will drain out. Allow the Container and the Air Conditioner to dry completely. Clean the air filter. Refit the rubber plug. Store the device in a dust-free location, preferably covered with a sheet of plastic.

# Troubleshooting

Problem	Possible Causes	Suggested Remedies
Unit does not start when pressing power button	Water full indicator lamp blinks, and water tank is full.	Empty water tank.
	Room temperature is lower than the setting temperature. (Cooling mode)	Reset the temperature
Not cool enough	The doors or windows are not closed.	Make sure all the windows and doors are closed.
	There are heat sources inside the room.	Remove the heat sources if possible
	Exhaust air hose is not connected or blocked.	Connect or clean the exhaust air hose.
	Temperature setting is too high.	Reset the temperature
	Air inlet is blocked.	Clean the air inlet.
Noisy	The ground is not level or not flat enough	Place the unit on a flat, level ground if possible
	The sound comes from the flowing of the refrigerant inside the air conditioner	It is normal.
E0 Code	Room temperature sensor failed	Replace room temperature sensor (the unit can also work without replacement.)
E2 Code	Water tank is full	Empty water tank

## PROOF OF PURCHASE

To receive warranty retain receipt as proof of purchase. (Refer to back of booklet).

# GOLDAIR

## SUPPORT AND TECHNICAL ADVICE

### Goldair – New Zealand

Monday – Friday 8am-5pm  
 Phone +64 (0)9 917 4000  
 Phone 0800 232 633  
 info@cdb.co.nz

### Goldair – Australia

Monday – Friday 8am-5pm  
 Phone +61 (0)3 9336 4423  
 Phone 1300 465 324  
 info@cdbgoldair.com.au



# One Year Warranty

Thank you for purchasing this Goldair product. Your product is warranted against faults and manufacture when used in normal domestic use for a period of **one year**. In non-domestic use Goldair limits the voluntary warranty to **three months**.

Goldair undertake to repair or replace this product at no charge if found to be defective due to a manufacturing fault during the warranty period.

This warranty excludes damage caused by misuse, neglect, shipping accident, incorrect installation, or work carried out by anyone other than a qualified electrical service technician.

PLEASE KEEP YOUR RECEIPT AS THIS WILL HELP VERIFY YOUR WARRANTY.

The benefits to you given by this warranty are in addition to other rights and remedies available to you under a law in relation to the goods or services to which this warranty relates.

In Australia, our goods come with guarantees that cannot be excluded under the Australian Consumer Law. You are entitled to a replacement or refund for a major failure and compensation for any other reasonably foreseeable loss or damage. You are also entitled to have the goods repaired or replaced if the goods fail to be of acceptable quality and the failure does not amount to a major failure.

In New Zealand this warranty is additional to the conditions and guarantees of the Consumers Guarantee Act (1993).

**Goldair – New Zealand**

CDB Goldair  
PO Box 100-707  
N.S.M.C  
Auckland

Phone +64 (0)9 917 4000  
Phone 0800 232 633  
[www.goldair.co.nz](http://www.goldair.co.nz)

**Goldair – Australia**

CDB Goldair Australia Pty  
PO Box 574  
South Morang  
Victoria, 3752

Phone +61 (0)3 9365 5100  
Phone 1300 GOLDAIR (1300 465 324)  
[www.goldair.com.au](http://www.goldair.com.au)

**Goldair One Year Warranty** (IMPORTANT: Please complete and retain this warranty card)

Name \_\_\_\_\_  
\_\_\_\_\_

Address \_\_\_\_\_  
\_\_\_\_\_  
\_\_\_\_\_  
\_\_\_\_\_

Place Of Purchase \_\_\_\_\_ Date of Purchase \_\_\_\_\_

Name Of Product \_\_\_\_\_ Model Number \_\_\_\_\_

Attach a copy of the purchase receipt to this warranty card