

Owner's Manual & Safety Instructions

Save This Manual Keep this manual for the safety warnings and precautions, assembly, operating, inspection, maintenance and cleaning procedures. Write the product's serial number in the back of the manual near the assembly diagram (or month and year of purchase if product has no number). Keep this manual and the receipt in a safe and dry place for future reference.

21c

BauerTM

20713E-B

14" ABRASIVE CUT OFF SAW



Visit our website at: <http://www.harborfreight.com>
Email our technical support at: productsupport@harborfreight.com

58091

When unpacking, make sure that the product is intact and undamaged. If any parts are missing or broken, please call 1-888-866-5797 as soon as possible.

Copyright© 2020 by Harbor Freight Tools®. All rights reserved.
No portion of this manual or any artwork contained herein may be reproduced in any shape or form without the express written consent of Harbor Freight Tools. Diagrams within this manual may not be drawn proportionally. Due to continuing improvements, actual product may differ slightly from the product described herein.
Tools required for assembly and service may not be included.

⚠ WARNING

Read this material before using this product.
Failure to do so can result in serious injury.
SAVE THIS MANUAL.

Table of Contents

Safety	2	Maintenance	12
Specifications	7	Parts List and Diagram	14
Setup	8	Warranty	16
Operation.....	9		

SAFETY



SETUP

OPERATION

MAINTENANCE

WARNING SYMBOLS AND DEFINITIONS	
	This is the safety alert symbol. It is used to alert you to potential personal injury hazards. Obey all safety messages that follow this symbol to avoid possible injury or death.
	Indicates a hazardous situation which, if not avoided, will result in death or serious injury.
	Indicates a hazardous situation which, if not avoided, could result in death or serious injury.
	Indicates a hazardous situation which, if not avoided, could result in minor or moderate injury.
	Addresses practices not related to personal injury.

IMPORTANT SAFETY INFORMATION

General Power Tool Safety Warnings

WARNING

Read all safety warnings, instructions, illustrations and specifications provided with this power tool. Failure to follow all instructions listed below may result in electric shock, fire and/or serious injury.

Save all warnings and instructions for future reference.

The term "power tool" in the warnings refers to your mains-operated (corded) power tool or battery-operated (cordless) power tool.

1. **Work area safety**
 - a. **Keep work area clean and well lit.**
Cluttered or dark areas invite accidents.
 - b. **Do not operate power tools in explosive atmospheres, such as in the presence of flammable liquids, gases or dust.** *Power tools create sparks which may ignite the dust or fumes.*
 - c. **Keep children and bystanders away while operating a power tool.** *Distractions can cause you to lose control.*

2. Electrical safety

- a. **Power tool plugs must match the outlet. Never modify the plug in any way. Do not use any adapter plugs with earthed (grounded) power tools.** *Unmodified plugs and matching outlets will reduce risk of electric shock.*
- b. **Avoid body contact with earthed or grounded surfaces, such as pipes, radiators, ranges and refrigerators.** *There is an increased risk of electric shock if your body is earthed or grounded.*
- c. **Do not expose power tools to rain or wet conditions.** *Water entering a power tool will increase the risk of electric shock.*
- d. **Do not abuse the cord. Never use the cord for carrying, pulling or unplugging the power tool. Keep cord away from heat, oil, sharp edges or moving parts.** *Damaged or entangled cords increase the risk of electric shock.*
- e. **When operating a power tool outdoors, use an extension cord suitable for outdoor use.** *Use of a cord suitable for outdoor use reduces the risk of electric shock.*
- f. **If operating a power tool in a damp location is unavoidable, use a ground fault circuit interrupter (GFCI) protected supply.** *Use of a GFCI reduces the risk of electric shock.*

3. Personal safety

- a. **Stay alert, watch what you are doing and use common sense when operating a power tool. Do not use a power tool while you are tired or under the influence of drugs, alcohol or medication.** *A moment of inattention while operating power tools may result in serious personal injury.*
- b. **Use personal protective equipment. Always wear eye protection.** *Protective equipment such as dust mask, non-skid safety shoes, hard hat, or hearing protection used for appropriate conditions will reduce personal injuries.*
- c. **Prevent unintentional starting. Ensure the switch is in the off-position before connecting to power source and/or battery pack, picking up or carrying the tool.** *Carrying power tools with your finger on the switch or energizing power tools that have the switch on invites accidents.*
- d. **Remove any adjusting key or wrench before turning the power tool on.** *A wrench or a key left attached to a rotating part of the power tool may result in personal injury.*
- e. **Do not overreach. Keep proper footing and balance at all times.** *This enables better control of the power tool in unexpected situations.*

- f. **Dress properly. Do not wear loose clothing or jewelry. Keep your hair, clothing and gloves away from moving parts.** *Loose clothes, jewelry or long hair can be caught in moving parts.*
- g. **If devices are provided for the connection of dust extraction and collection facilities, ensure these are connected and properly used.** *Use of dust collection can reduce dust-related hazards.*
- h. **Do not let familiarity gained from frequent use of tools allow you to become complacent and ignore tool safety principles.** *A careless action can cause severe injury within a fraction of a second.*
- i. Only use safety equipment that has been approved by an appropriate standards agency. Unapproved safety equipment may not provide adequate protection. Eye protection must be ANSI-approved and breathing protection must be NIOSH-approved for the specific hazards in the work area.
- j. Avoid unintentional starting. Prepare to begin work before turning on the tool.
- k. Do not depress the spindle lock when starting or during operation.
- l. Do not leave the tool unattended when it is plugged into an electrical outlet. Turn off the tool, and unplug it from its electrical outlet before leaving.
- m. This product is not a toy. Keep it out of reach of children.
- n. People with pacemakers should consult their physician(s) before use. Electromagnetic fields in close proximity to heart pacemaker could cause pacemaker interference or pacemaker failure. In addition, people with pacemakers should:
 - Avoid operating alone.
 - Do not use with Trigger locked on.
 - Properly maintain and inspect to avoid electrical shock.
 - Properly ground power cord.Ground Fault Circuit Interrupter (GFCI) should also be implemented – it prevents sustained electrical shock.
- o. The warnings, precautions, and instructions discussed in this instruction manual cannot cover all possible conditions and situations that may occur. It must be understood by the operator that common sense and caution are factors which cannot be built into this product, but must be supplied by the operator.

4. Power tool use and care

- a. **Do not force the power tool. Use the correct power tool for your application.** *The correct power tool will do the job better and safer at the rate for which it was designed.*

- b. **Do not use the power tool if the switch does not turn it on and off.** *Any power tool that cannot be controlled with the switch is dangerous and must be repaired.*
 - c. **Disconnect the plug from the power source and/or remove the battery pack, if detachable, from the power tool before making any adjustments, changing accessories, or storing power tools.** *Such preventive safety measures reduce the risk of starting the power tool accidentally.*
 - d. **Store idle power tools out of the reach of children and do not allow persons unfamiliar with the power tool or these instructions to operate the power tool.** *Power tools are dangerous in the hands of untrained users.*
 - e. **Maintain power tools and accessories. Check for misalignment or binding of moving parts, breakage of parts and any other condition that may affect the power tool's operation. If damaged, have the power tool repaired before use.** *Many accidents are caused by poorly maintained power tools.*
 - f. **Keep cutting tools sharp and clean.** *Properly maintained cutting tools with sharp cutting edges are less likely to bind and are easier to control.*
 - g. **Use the power tool, accessories and tool bits etc. in accordance with these instructions, taking into account the working conditions and the work to be performed.** *Use of the power tool for operations different from those intended could result in a hazardous situation.*
 - h. **Keep handles and grasping surfaces dry, clean and free from oil and grease.** *Slippery handles and grasping surfaces do not allow for safe handling and control of the tool in unexpected situations.*
5. **Service**
- a. **Have your power tool serviced by a qualified repair person using only identical replacement parts.** *This will ensure that the safety of the power tool is maintained.*
 - b. **Maintain labels and nameplates on the tool.** *These carry important safety information. If unreadable or missing, contact Harbor Freight Tools for a replacement.*
6. **Cut-off machine safety warnings**
- a. **Position yourself and bystanders away from the plane of the rotating wheel.** *The guard helps to protect the operator from broken wheel fragments and accidental contact with wheel.*
 - b. **Use only bonded reinforced or diamond cut-off wheels for your power tool.** *Just because an accessory can be attached to your power tool, it does not assure safe operation.*
 - c. **The rated speed of the accessory must be at least equal to the maximum speed marked on the power tool.** *Accessories running faster than their rated speed can break and fly apart.*
 - d. **Wheels must be used only for recommended applications. For example: do not grind with the side of a cut-off wheel.** *Abrasive cut-off wheels are intended for peripheral grinding, side forces applied to these wheels may cause them to shatter.*
 - e. **Always use undamaged wheel flanges that are of correct diameter for your selected wheel.** *Proper wheel flanges support the wheel thus reducing the possibility of wheel breakage.*
 - f. **The outside diameter and the thickness of your accessory must be within the capacity rating of your power tool.** *Incorrectly sized accessories cannot be adequately guarded or controlled.*
 - g. **The arbour size of wheels and flanges must properly fit the spindle of the power tool.** *Wheels and flanges with arbour holes that do not match the mounting hardware of the power tool will run out of balance, vibrate excessively and may cause loss of control.*
 - h. **Do not use damaged wheels. Before each use, inspect the wheels for chips and cracks. If the power tool or wheel is dropped, inspect for damage or install an undamaged wheel. After inspecting and installing the wheel, position yourself and bystanders away from the plane of the rotating wheel and run the power tool at maximum no load speed for one minute.** *Damaged wheels will normally break apart during this test time.*
 - i. **Wear personal protective equipment. Depending on application, use face shield, safety goggles or safety glasses. As appropriate, wear dust mask, hearing protectors, gloves and shop apron capable of stopping small abrasive or workpiece fragments.** *The eye protection must be capable of stopping flying debris generated by various operations. The dust mask or respirator must be capable of filtering particles generated by your operation. Prolonged exposure to high intensity noise may cause hearing loss.*
 - j. **Keep bystanders a safe distance away from work area. Anyone entering the work area must wear personal protective equipment.** *Fragments of workpiece or of a broken wheel may fly away and cause injury beyond immediate area of operation.*
 - k. **Position the cord clear of the spinning accessory.** *If you lose control, the cord may be cut or snagged and your hand or arm may be pulled into the spinning wheel.*

l. **Regularly clean the power tool's air vents.**

The motor's fan can draw the dust inside the housing and excessive accumulation of powdered metal may cause electrical hazards.

m. **Do not operate the power tool near flammable materials. Do not operate the power tool while placed on a combustible surface such as wood.** *Sparks could ignite these materials.*

n. **Do not use accessories that require liquid coolants.** *Using water or other liquid coolants may result in electrocution or shock.*

7. **Kickback and related warnings**

- Kickback is a sudden reaction to a pinched or snagged rotating wheel. Pinching or snagging causes rapid stalling of the rotating wheel which in turn causes the uncontrolled cutting unit to be forced upwards toward the operator.

- For example, if an abrasive wheel is snagged or pinched by the workpiece, the edge of the wheel that is entering into the pinch point can dig into the surface of the material causing the wheel to climb out or kick out. Abrasive wheels may also break under these conditions.

Kickback is the result of power tool misuse and/or incorrect operating procedures or conditions and can be avoided by taking proper precautions as given below.

a. **Maintain a firm grip on the power tool and position your body and arm to allow you to resist kickback forces.**

The operator can control upward kickback forces, if proper precautions are taken.

b. **Do not position your body in line with the rotating wheel.** *If kickback occurs, it will propel the cutting unit upwards toward the operator.*

c. **Do not attach a saw chain, woodcarving blade, segmented diamond wheel with a peripheral gap greater than 10 mm or toothed saw blade.** *Such blades create frequent kickback and loss of control.*

d. **Do not "jam" the wheel or apply excessive pressure.** *Do not attempt to make an excessive depth of cut. Overstressing the wheel increases the loading and susceptibility to twisting or binding of the wheel in the cut and the possibility of kickback or wheel breakage.*

e. **When the wheel is binding or when interrupting a cut for any reason, switch off the power tool and hold the cutting unit motionless in the material until the wheel comes to a complete stop. Never attempt to remove the wheel from the cut while the wheel is in motion or kickback may occur.** *Investigate and take corrective actions to eliminate the cause of wheel binding.*

f. **Do not restart the cutting operation in the workpiece. Let the wheel reach full speed and carefully re-enter the cut.** *The wheel may bind, walk up or kickback if the power tool is restarted in the workpiece.*

g. **Support any oversized workpiece to minimise the risk of wheel pinching and kickback.** *Large workpieces tend to sag under their own weight. Supports must be placed under the workpiece near the line of cut and near the edge of the workpiece on both sides of the wheel.*

8. **Vibration Safety**

This tool vibrates during use.

Repeated or long-term exposure to vibration may cause temporary or permanent physical injury, particularly to the hands, arms and shoulders. To reduce the risk of vibration-related injury:

- Anyone using vibrating tools regularly or for an extended period should first be examined by a doctor and then have regular medical check-ups to ensure medical problems are not being caused or worsened from use. Pregnant women or people who have impaired blood circulation to the hand, past hand injuries, nervous system disorders, diabetes, or Raynaud's Disease should not use this tool. If you feel any symptoms related to vibration (such as tingling, numbness, and white or blue fingers), seek medical advice as soon as possible.
- Do not smoke during use. Nicotine reduces the blood supply to the hands and fingers, increasing the risk of vibration-related injury.
- Wear suitable gloves to reduce the vibration effects on the user.
- Use tools with the lowest vibration when there is a choice.
- Include vibration-free periods each day of work.
- Grip tool as lightly as possible (while still keeping safe control of it). Let the tool do the work.
- To reduce vibration, maintain the tool as explained in this manual. If any abnormal vibration occurs, stop use immediately.

Grounding

⚠️ WARNING



TO PREVENT ELECTRIC SHOCK AND DEATH FROM INCORRECT GROUNDING WIRE CONNECTION:

Check with a qualified electrician if you are in doubt as to whether the outlet is properly grounded. Do not modify the power cord plug provided with the tool. Never remove the grounding prong from the plug. Do not use the tool if the power cord or plug is damaged. If damaged, have it repaired by a service facility before use. If the plug will not fit the outlet, have a proper outlet installed by a qualified electrician.

Grounded Tools: Tools with Three Prong Plugs

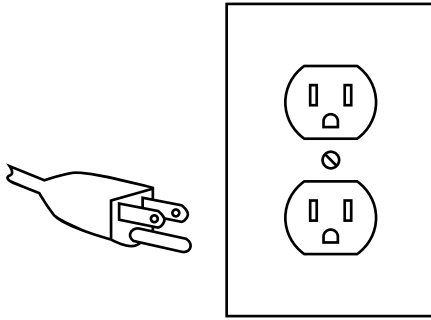

3-Prong Plug and Outlet

1. Tools marked with "Grounding Required" have a three wire cord and three prong grounding plug. The plug must be connected to a properly grounded outlet. If the tool should electrically malfunction or break down, grounding provides a low resistance path to carry electricity away from the user, reducing the risk of electric shock. (See 3-Prong Plug and Outlet.)

2. The grounding prong in the plug is connected through the green wire inside the cord to the grounding system in the tool. The green wire in the cord must be the only wire connected to the tool's grounding system and must never be attached to an electrically "live" terminal. (See 3-Prong Plug and Outlet.)
3. The tool must be plugged into an appropriate outlet, properly installed and grounded in accordance with all codes and ordinances. The plug and outlet should look like those in the preceding illustration. (See 3-Prong Plug and Outlet.)

Double Insulated Tools: Tools with Two Prong Plugs

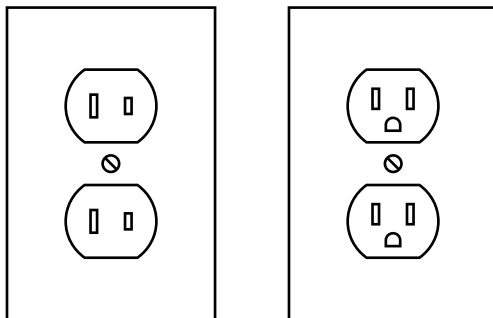

Outlets for 2-Prong Plug

1. Tools marked "Double Insulated" do not require grounding. They have a special double insulation system which satisfies OSHA requirements and complies with the applicable standards of Underwriters Laboratories, Inc., the Canadian Standard Association, and the National Electrical Code.
2. Double insulated tools may be used in either of the 120 volt outlets shown in the preceding illustration. (See Outlets for 2-Prong Plug.)

Extension Cords

1. **Grounded** tools require a three wire extension cord. **Double Insulated** tools can use either a two or three wire extension cord.
2. As the distance from the supply outlet increases, you must use a heavier gauge extension cord. Using extension cords with inadequately sized wire causes a serious drop in voltage, resulting in loss of power and possible tool damage. (See Table A.)
3. The smaller the gauge number of the wire, the greater the capacity of the cord. For example, a 14 gauge cord can carry a higher current than a 16 gauge cord. (See Table A.)
4. When using more than one extension cord to make up the total length, make sure each cord contains at least the minimum wire size required. (See Table A.)





- If you are using one extension cord for more than one tool, add the nameplate amperes and use the sum to determine the required minimum cord size. (See Table A.)
- If you are using an extension cord outdoors, make sure it is marked with the suffix "W-A" ("W" in Canada) to indicate it is acceptable for outdoor use.
- Make sure the extension cord is properly wired and in good electrical condition. Always replace a damaged extension cord or have it repaired by a qualified electrician before using it.
- Protect the extension cords from sharp objects, excessive heat, and damp or wet areas.

NAMEPLATE AMPERES (at full load)	EXTENSION CORD LENGTH				
	25'	50'	75'	100'	150'
0 – 2.0	18	18	18	18	16
2.1 – 3.4	18	18	18	16	14
3.5 – 5.0	18	18	16	14	12
5.1 – 7.0	18	16	14	12	12
7.1 – 12.0	18	14	12	10	-
12.1 – 16.0	14	12	10	-	-
16.1 – 20.0	12	10	-	-	-

* Based on limiting the line voltage drop to five volts at 150% of the rated amperes.

Symbology

	Double Insulated
V	Volts
~	Alternating Current
A	Amperes
n ₀ xxxx/min.	No Load Revolutions per Minute (RPM)

	WARNING marking concerning Risk of Eye Injury. Wear ANSI-approved safety goggles with side shields.
	Read the manual before set-up and/or use.
	WARNING marking concerning Risk of Fire. Do not cover ventilation ducts. Keep flammable objects away.
	WARNING marking concerning Risk of Electric Shock. Properly connect power cord to appropriate outlet.

Specifications

Electrical Rating	120VAC / 60Hz / 15A
Motor No Load Speed	4200 RPM
Maximum Wheel Diameter	14" (355mm)
Arbor	M10 1" (25.4mm) round
Wheel Thickness	1/8" Maximum
Cutting Capacity	Square Steel: 4-5/16" x 4-5/16" Rectangular Steel: 6-11/16" x 3-15/16" Angle Iron: 5-3/8" x 5-3/8"

Setup - Before Use:



Read the **ENTIRE IMPORTANT SAFETY INFORMATION** section at the beginning of this manual including all text under subheadings therein before set up or use of this product.

Note: For additional information regarding the parts listed in the following pages, refer to *Parts List and Diagram* on page 14.

Mounting

1. Ensure that the Saw is always used on a stable and level surface.
2. Mount Saw to workbench using appropriate hardware through the holes in the base.

Power Supply Requirements

120VAC / 60Hz

Functions

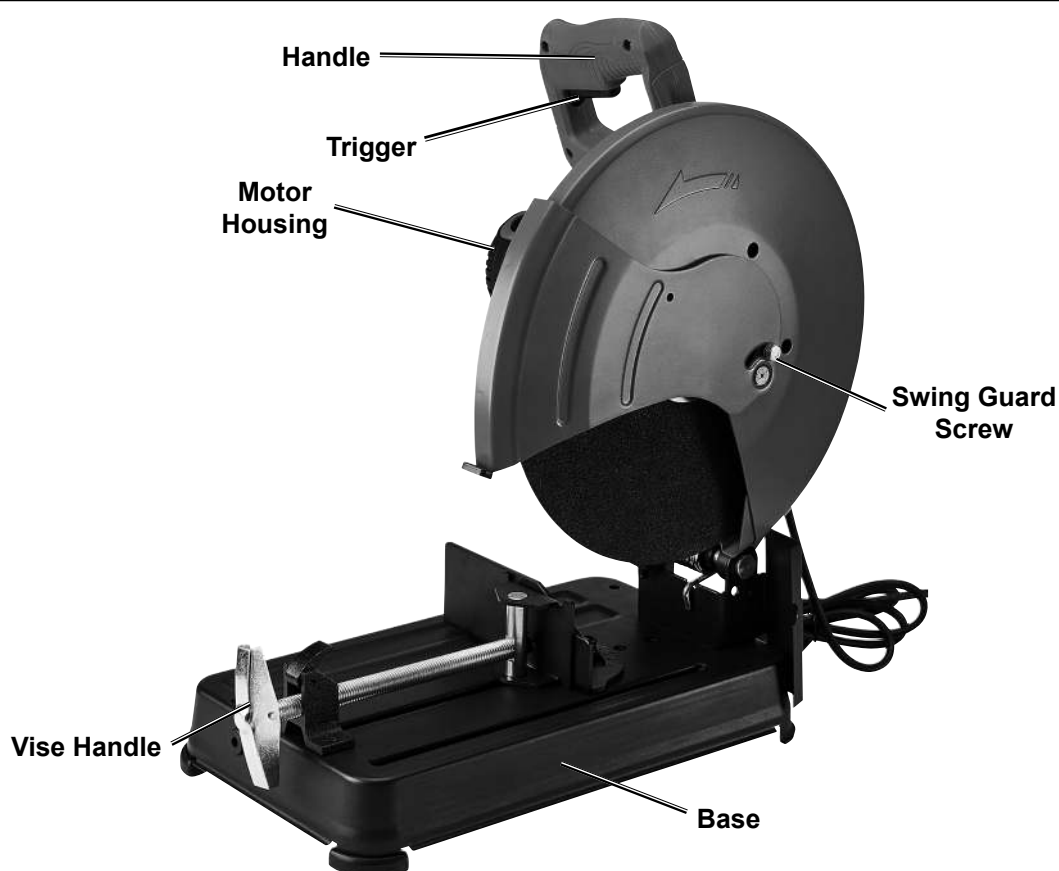

Operating Instructions



Read the **ENTIRE IMPORTANT SAFETY INFORMATION** section at the beginning of this manual including all text under subheadings therein before set up or use of this product.

WARNING

TO PREVENT SERIOUS INJURY FROM ACCIDENTAL OPERATION:

Release the Trigger, unplug the tool from its electrical outlet before performing any inspection, maintenance, or cleaning procedures.

TO PREVENT SERIOUS INJURY: DO NOT OPERATE WITH ANY GUARD DISABLED, DAMAGED, OR REMOVED. Moving guards must move freely and close instantly.

Workpiece and Work Area Set Up

1. Designate a work area that is clean and well lit. The work area must not allow access by children or pets to prevent distraction and injury.
2. Route the power cord along a safe route to reach the work area without creating a tripping hazard or exposing the power cord to possible damage. The power cord must reach the work area with enough extra length to allow free movement while working.
3. Secure loose workpieces using a vise or clamps (not included) to prevent movement while working.
4. There must not be objects, such as utility lines, nearby that will present a hazard while working.

Tool Changing

WARNING! TO PREVENT SERIOUS INJURY: Wear heavy-duty work gloves when handling abrasive wheels.

Installing a Cut-Off (Grinding) Wheel

1. The Cut-Off Wheel (sold separately) **MUST** be:
 - rated to at least 4200 RPM.
 - no larger than 14" (355mm) in diameter.
 - fitted with a 1" round arbor hole.
 - suitable for edge grinding, not surface grinding.
 - dry and clean.
 - proven undamaged by inspection and by the ring-test explained below.
2. Raise the Saw if it is locked down by pushing down on the Handle and pulling out the Lock Ball.
3. Open the Swing Guard and tighten the Swing Guard Screw to secure it while working on the Cut-Off Wheel.
4. Push the Spindle Lock towards the Fixed Guard. Rotate the Cut-Off Wheel until the Spindle Lock slides into place.
5. While continuing to hold down the Spindle Lock, loosen the Arbor Bolt.

6. Remove the Arbor Bolt, the Flange Washer, the Outer Flange, and the Cut-Off Wheel. See **Figure A**.

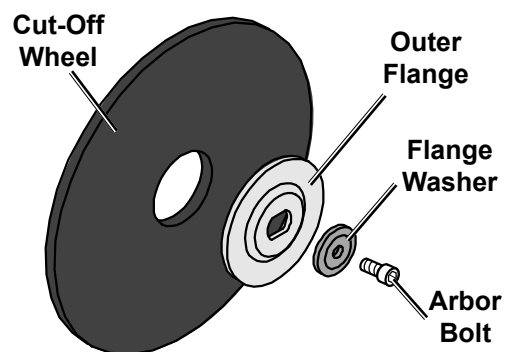

Figure A: Removing Cut-Off Wheel

7. Closely inspect the new wheel before mounting. Perform a **ring-test** on the wheel as follows:
 - a. Suspend wheel using a dowel or finger through the arbor hole.
 - b. Tap the flat side of the wheel with a light non-metallic object, such as a screwdriver handle, at a point 45° from the vertical center line on each side of the wheel and 1 - 2 inches from the edge of the wheel (see **Figure B**).

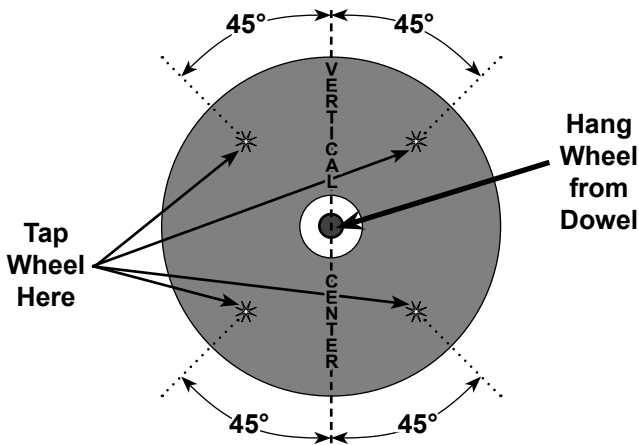

Figure B: Cut-Off Wheel Ring-Test

- c. Rotate the wheel 90° and repeat the test until the entire wheel has been checked.
 - d. An undamaged wheel will give a clear tone. If cracked, there will be a dead sound and not a clear ring.
8. Replace with the new Cut-Off Wheel, and reassemble the parts shown in **Figure A**. The concave side of the Outer Flange must face the Wheel. See **Figure C**.

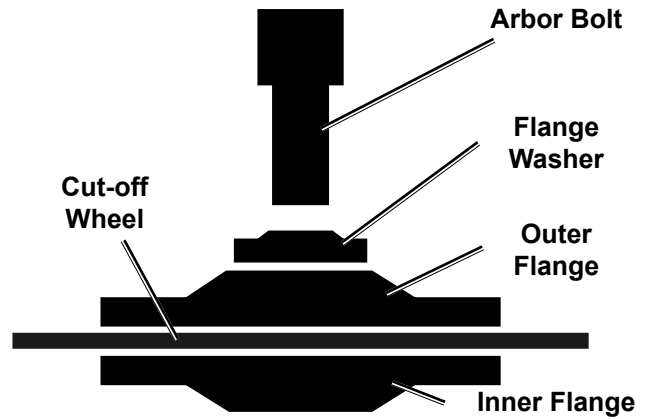

Figure C: Cut-Off Wheel Hardware

9. For wheels with paper gaskets (blotters) or metal gaskets: Slip the grinding wheel onto the Spindle with the gasket first. The gasket should be centered on the grinding wheel and the wheel and gasket should rest flat against the Inner Flange.
 - ⚠ **WARNING!** To prevent serious injury: Gaskets must be used for all grinding wheels they are provided with. Gaskets help prevent grinding wheel damage and wheel slippage, causes of wheel failure.
10. While holding the Spindle Lock, tighten the Arbor Bolt.
 - ⚠ **WARNING:** To prevent serious injury: Do not overtighten the Arbor Bolt. Overtightening can damage the wheel, causing wheel failure.
11. LOOSEN THE SWING GUARD SCREW and make sure that the Swing Guard moves freely back into place before operation.
12. **CAUTION!** Adjust the Cutting Depth whenever replacing a worn wheel.

Cutting Depth Adjustment

1. Loosen the Nut on the Depth Adjustment Bolt.
2. Turn the Depth Adjustment Bolt to change the depth so that the cut-off wheel will not contact the base at any time during cutting.
3. After adjustment, tighten the Nut down against the Bracket to lock the adjustment in place.

Setting and Testing

1. Ensure the Cut-Off Wheel is properly attached to the Saw and the depth adjustment has been properly set.
2. Ensure the Saw is properly mounted to the workbench or secured to a stable level surface.
3. Connect the Saw's Power Cord to 120VAC grounded outlet. Slide the Trigger Lock and squeeze the Trigger. Run the tool for at least 30 seconds.
4. If abnormal noise/vibration occurs or the Cut-Off Wheel slips, have the problem corrected before further use.
5. Release Trigger and unplug Saw.

General Instructions for Use

⚠️WARNING

TO PREVENT SERIOUS INJURY:

DO NOT OPERATE WITH ANY GUARD DISABLED, DAMAGED, OR REMOVED.

Moving guards must move freely and close instantly.

Swing Guard Screw MUST be loose before operation.

WARNING! TO PREVENT SERIOUS INJURY: Wear appropriate hearing protection and ANSI-approved safety goggles during use.

1. Using the vise, secure your workpiece and, if necessary, adjust the angle of the cut.
2. Raise the Saw by pushing down on the Handle and pulling out the Lock Ball.
3. Be sure the Trigger is in the off-position then plug the Power Cord into the nearest 120 VAC grounded outlet.
4. Slide the Trigger Lock and squeeze the Trigger to start the Saw. Allow the Cut-Off Wheel to attain full speed.
5. **Make sure that all guards are in place and in proper working order and that all adjustment knobs are tight before operation.**
6. With one hand on the Handle and the other hand clear, slowly bring the Cut-Off Wheel down onto the workpiece, letting the Saw do the work. Do not apply excessive force.
7. If the Cut-Off Wheel does not cut all the way through the workpiece:
 - a. Raise the Saw and release the Trigger.
 - b. Unplug the Saw.
 - c. Wait until the Cut-Off Wheel comes to a full stop then remove the workpiece.
 - d. Set the depth adjustment to a deeper setting (see *Cutting Depth Adjustment on page 10*).
 - e. After adjusting the depth, bring the Saw all the way down to make sure the Cut-Off Wheel doesn't contact the Base.
 - f. If it does contact any part of the Base, re-adjust the depth so it doesn't.
 - g. Repeat the cutting process starting with step 1.

WARNING! TO PREVENT SERIOUS INJURY:

The tool will restart automatically if stalled.

8. Once the cut is completed, turn off the Saw by releasing the Trigger and unplug the unit. Do not attempt to remove the workpiece until the Cut-Off Wheel has stopped moving.
9. To prevent accidents, after use turn off the tool and unplug it. Lock it down by pushing it down as far as it will go and then pushing in the Lock Ball. Clean, then store the tool indoors out of children's reach.

Setting Up an Angle Cut

1. To cut at various angles (up to 45°), adjust the Angle Scale by loosening the two Bolts.
2. Adjust the Angle Scale to the desired setting and then tighten both Bolts.
3. To reposition the Angle Scale for a wider workpiece, remove both of the Bolts, and reattach the Angle Scale at the upper two screw holes.

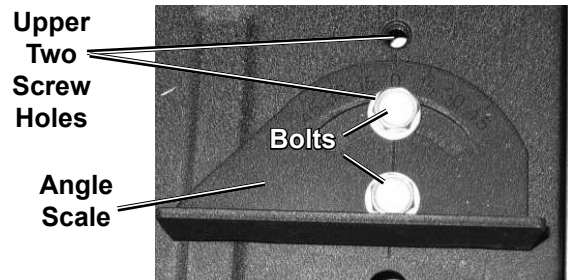

Angle Cut Set Up

Using the Vise

1. After setting the cutting angle, secure loose work pieces using the vise to prevent movement while working:
 - a. Put the Quick Release in the position and push the Vise Handle until the vise jaw is up against the workpiece.
 - b. Tighten the Vise Handle to secure the workpiece.

Note: To cut the workpiece at an angle, see *Setting Up an Angle Cut on page 11*.

2. To release the workpiece, loosen the Vise Handle a few turns, lift up the Quick Release and pull the Vise Handle open.

Maintenance and Servicing Instructions



Procedures not specifically explained in this manual must be performed only by a qualified technician.

WARNING

TO PREVENT SERIOUS INJURY FROM ACCIDENTAL OPERATION:

Make sure that the Trigger is in the off-position and unplug the tool from its electrical outlet before performing any procedure in this section.

TO PREVENT SERIOUS INJURY FROM TOOL FAILURE:

Do not use damaged equipment. If abnormal noise or vibration occurs, have the problem corrected before further use.

Cleaning, Maintenance, and Lubrication

1. **BEFORE EACH USE**, inspect the general condition of the tool. Check for:
 - loose hardware,
 - misalignment or binding of moving parts,
 - cracked or broken parts,
 - damaged electrical wiring, and
 - any other condition that may affect its safe operation.
2. **AFTER USE**, wipe external surfaces of the tool with clean cloth.
3. Periodically, wear ANSI-approved safety goggles and NIOSH-approved breathing protection and blow dust and grit out of the motor vents using dry compressed air.
4. **WARNING! TO PREVENT SERIOUS INJURY: If the supply cord of this power tool is damaged, it must be replaced only by a qualified service technician.**

Accessory Storage and Handling

1. Handle accessories carefully to prevent dropping or bumping. Do not use wheels that have been dropped or bumped.
2. Store accessories in shelves, racks, boxes, or drawers. Keep storage area dry and above freezing. Any grinding or cut-off wheels exposed to humidity or freezing temperatures must not be used.

Troubleshooting

Problem	Possible Causes	Likely Solutions
Tool will not start.	<ol style="list-style-type: none"> 1. Cord not connected. 2. No power at outlet. 3. Tool's thermal reset breaker tripped (if equipped). 4. Internal damage or wear. (Carbon brushes or Trigger, for example.) 	<ol style="list-style-type: none"> 1. Check that cord is plugged in. 2. Check power at outlet. If outlet is unpowered, turn off tool and check circuit breaker. If breaker is tripped, make sure circuit is right capacity for tool and circuit has no other loads. 3. Turn off tool and allow to cool. Press reset button on tool. 4. Have technician service tool.
Tool operates slowly.	<ol style="list-style-type: none"> 1. Forcing tool to work too fast. 2. Extension cord too long or cord diameter too small. 	<ol style="list-style-type: none"> 1. Allow tool to work at its own rate. 2. Eliminate use of extension cord. If an extension cord is needed, use one with the proper diameter for its length and load. See <i>Extension Cords</i> in <i>Grounding</i> section on page 6.
Performance decreases over time.	<ol style="list-style-type: none"> 1. Wheel worn. 2. Carbon brushes worn or damaged. 	<ol style="list-style-type: none"> 1. Replace wheel. 2. Have qualified technician replace brushes.
Excessive noise or rattling.	Internal damage or wear. (Carbon brushes or bearings, for example.)	Have technician service tool.
Overheating.	<ol style="list-style-type: none"> 1. Forcing tool to work too fast. 2. Wheel misaligned. 3. Wheel worn or dull. 4. Blocked motor housing vents. 5. Motor being strained by long or small diameter extension cord. 	<ol style="list-style-type: none"> 1. Allow tool to work at its own rate. 2. Check and correct wheel alignment. 3. Replace wheel. 4. Wear ANSI-approved safety goggles and NIOSH-approved dust mask/respirator while blowing dust out of motor using compressed air. 5. Eliminate use of extension cord. If an extension cord is needed, use one with the proper diameter for its length and load. See <i>Extension Cords</i> in <i>Grounding</i> section on page 6.



Follow all safety precautions whenever diagnosing or servicing the tool. Disconnect power supply before service.

PLEASE READ THE FOLLOWING CAREFULLY

THE MANUFACTURER AND/OR DISTRIBUTOR HAS PROVIDED THE PARTS LIST AND ASSEMBLY DIAGRAM IN THIS MANUAL AS A REFERENCE TOOL ONLY. NEITHER THE MANUFACTURER OR DISTRIBUTOR MAKES ANY REPRESENTATION OR WARRANTY OF ANY KIND TO THE BUYER THAT HE OR SHE IS QUALIFIED TO MAKE ANY REPAIRS TO THE PRODUCT, OR THAT HE OR SHE IS QUALIFIED TO REPLACE ANY PARTS OF THE PRODUCT. IN FACT, THE MANUFACTURER AND/OR DISTRIBUTOR EXPRESSLY STATES THAT ALL REPAIRS AND PARTS REPLACEMENTS SHOULD BE UNDERTAKEN BY CERTIFIED AND LICENSED TECHNICIANS, AND NOT BY THE BUYER. THE BUYER ASSUMES ALL RISK AND LIABILITY ARISING OUT OF HIS OR HER REPAIRS TO THE ORIGINAL PRODUCT OR REPLACEMENT PARTS THERETO, OR ARISING OUT OF HIS OR HER INSTALLATION OF REPLACEMENT PARTS THERETO

Parts List and Diagram

Parts List

SAFETY

SETUP

OPERATION

MAINTENANCE

Part	Description	Qty
1	Cross Pin	1
2	Sleeve	1
3	Big Torsion Spring	1
4	Flat Washer	2
5	Nut, M10	1
6	Base	1
7	Rubber Feet	3
8	Bolt, M8 x 12 & Spring Washer, 8	2
9	Vise Handle	1
10	Flush Head Rivet, M5 x 24	1
11	Screw Rod	1
12	Nut Seat	1
13	Cylindrical Pin Ø 6 x 32	1
14	Quick Release	1
15	Wrench, S8	1
16	Clamp Base	1
17	Screw Pin	1
18	Flat Washer, Ø8 x Ø16 x 0.8	1
19	Open Pin, Ø 2.5 x 25	1
20	Angle Scale	1
21	Bolt, M10 x 20	2
22	Lock Ball	1
23	Seal Ring, Ø5 x 1.8	1
24	Nut ,M6	3
25	Self-Lock Pin	1
26	Depth Adjustment Bolt, M10 x 30	1
27	Nut, M10	1
28	Bolt, M6 x 16	1
29	Bracket	1
30	Bolt, M5 x 12	1
31	Bolt, M5 x 45	4
32	Spindle Lock, Bolt, ST4.8 x 75	2
33	Limit Pin	1
34	Self-Lock Pin Spring	1
35	Key, 4 x 5 x 13	1
36	Chafing Cap	2
37	Bolt, M5 x 16	4
38	Rubber Sleeve	1
39	Fixed Bolt	1
40	Swing Guard Screw	1
41	Paper Spacer	1
42	Swing Guard	1
43	Arbor Bolt, M10 x 20	1
44	Plate Cover	1

Part	Description	Qty
45	Outer Flange	1
46	Cut-Off Wheel (sold separately)	0
47	Inner Flange	1
48	Fixed Guard	1
49	Ring, 15 x 1.8	1
50	Inner Plate Sleeve	1
51	Output Axis	1
52	Bearing, 6203-2RS	1
53	Front Cover	1
54	Seal Ring, Ø63 x 1.5	1
55	Big Gear	1
56	Bearing, 6000-2RS	1
57	Support Arm	1
58	Screw, M5 x 25	1
59	Lock Nut, M5	1
60	Bolt, M5 x 35	2
61	Rubber Pin	1
62	Bearing, 6202-2RS	1
63	Rotor	1
64	Bearing, 629-2RS	1
65	Rubber Bearing Sleeve	1
66	Block Circle	1
67	Stator	1
68	Motor Housing	1
69	Carbon Brush	2
70	Brush Holder	2
71	Brush Holder Cover	2
72	Bolt, M6 x 10	2
73	Motor Housing Cover	1
74	Bolt, ST4.2 x 14	11
75	Bolt, ST4.2 x 20	1
76	Upper Handle Mount	1
77	Handle	1
78	Trigger	1
79	Cable Cover	1
80	Power Cable	1
81	Lower Handle Mount	1
82	Nut, M5	3
83	Trigger Lock	1
84	Tension Disc	1
85	External Circlips 17	1
86	External Circlips 15	1
87	Wrench Fixed Ring	1
88	Bolt, M5 x 16	1

Record Product's Serial Number Here: _____

Note: If product has no serial number, record month and year of purchase instead.

Note: Some parts are listed and shown for illustration purposes only, and are not available individually as replacement parts. Specify UPC 193175432292 when ordering parts.

Assembly Diagram

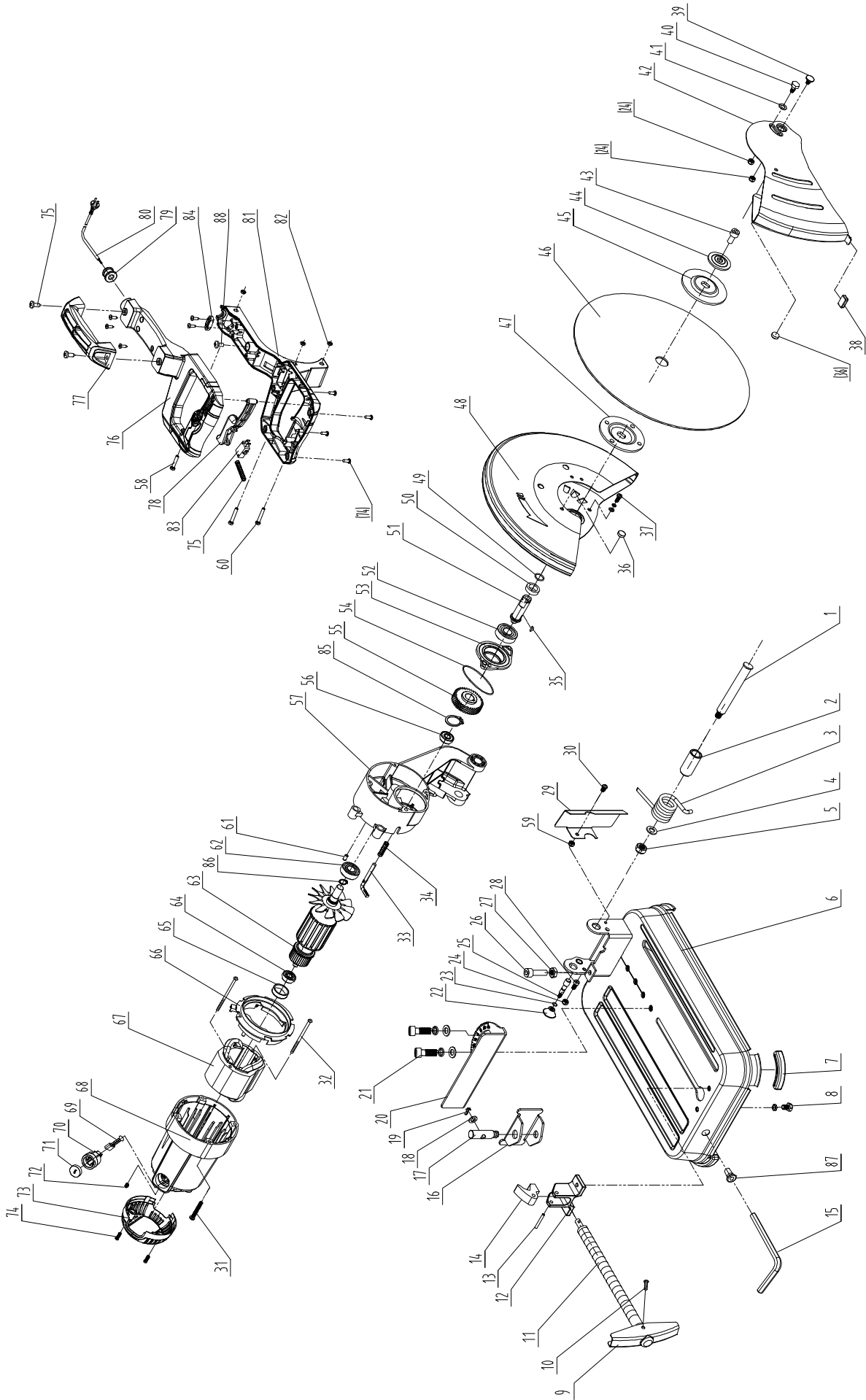

SAFETY

SETUP

OPERATION

MAINTENANCE

Limited 90 Day Warranty

Harbor Freight Tools Co. makes every effort to assure that its products meet high quality and durability standards, and warrants to the original purchaser that this product is free from defects in materials and workmanship for the period of 90 days from the date of purchase. This warranty does not apply to damage due directly or indirectly, to misuse, abuse, negligence or accidents, repairs or alterations outside our facilities, criminal activity, improper installation, normal wear and tear, or to lack of maintenance. We shall in no event be liable for death, injuries to persons or property, or for incidental, contingent, special or consequential damages arising from the use of our product. Some states do not allow the exclusion or limitation of incidental or consequential damages, so the above limitation of exclusion may not apply to you. THIS WARRANTY IS EXPRESSLY IN LIEU OF ALL OTHER WARRANTIES, EXPRESS OR IMPLIED, INCLUDING THE WARRANTIES OF MERCHANTABILITY AND FITNESS.

To take advantage of this warranty, the product or part must be returned to us with transportation charges prepaid. Proof of purchase date and an explanation of the complaint must accompany the merchandise. If our inspection verifies the defect, we will either repair or replace the product at our election or we may elect to refund the purchase price if we cannot readily and quickly provide you with a replacement. We will return repaired products at our expense, but if we determine there is no defect, or that the defect resulted from causes not within the scope of our warranty, then you must bear the cost of returning the product.

This warranty gives you specific legal rights and you may also have other rights which vary from state to state.

The logo for Bauer, featuring the word "Bauer" in a bold, italicized, sans-serif font. The letters are black with a white outline, and a small trademark symbol (TM) is located at the bottom right of the word.

26541 Agoura Road • Calabasas, CA 91302 • 1-888-866-5797