

HIKOKI

角向磨光机
Disc Grinder

中文
English

G 10SF3

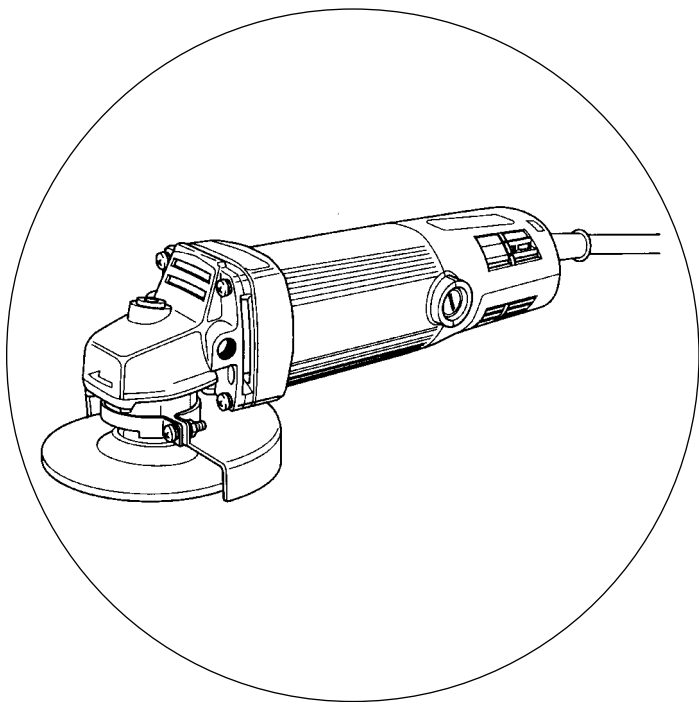

保留备用
Keep for future reference



使用说明书
Handling instructions



目次

电动工具通用安全警告.....	2	规格.....	7
砂磨、砂光或切割操作的通用 安全警告.....	4	标准附件.....	8
反弹和相关警告.....	5	选购附件（分开销售）.....	8
对磨削和金刚石砂轮切割操作的 专用安全警告.....	6	用途.....	8
对金刚石砂轮切割操作的附加 专用安全警告.....	6	作业之前.....	9
砂光操作的专用安全警告.....	7	实用角向磨光机的应用.....	9
使用角向磨光机时的注意事项.....	7	砂轮的装卸.....	10
符号.....	7	安装选配部件的方法.....	11
		维护和检查.....	12
		维修零部件一览表.....	14

电动工具通用安全警告

⚠ 警告！

阅读所有警告和所有说明。

不遵照以下警告和说明会导致电击、着火和 / 或严重伤害。

保存所有警告和说明书以备查阅。

在所有下列的警告中术语“电动工具”指市电驱动(有线)电动工具或电池驱动(无线)电动工具。

1) 工作场地的安全

- a) 保持工作场地清洁和明亮。
混乱和黑暗的场地会引发事故。
- b) 不要在易爆环境，如有易燃液体、气体或粉尘的环境下操作电动工具。
电动工具产生的火花会点燃粉尘或气体。
- c) 让儿童和旁观者离开后操作电动工具。
注意力不集中会使操作者失去对工具的控制。

2) 电气安全

- a) 电动工具插头必须与插座相配。绝不能以任何方式改装插头。需接地的电动工具不能使用任何转换插头。
未经改装的插头和相配的插座将减少电击危险。
- b) 避免人体接触接地表面，如管道、散热片和冰箱。
如果你身体接地会增加电击危险。
- c) 不得将电动工具暴露在雨中或潮湿环境中。
水进入电动工具将增加电击危险。

- d) 不得滥用电线。绝不能用电线搬运、拉动电动工具或拔出其插头。使电线远离热源、油、锐边或运动部件。
受损或缠绕的软线会增加电击危险。
- e) 当在户外使用电动工具时，使用适合户外使用的外接软线。
适合户外使用的软线将减少电击危险。
- f) 如果在潮湿环境下操作电动工具是不可避免的，应使用剩余电流动作保护器（RCD）。
使用RCD可减小电击危险。

3) 人身安全

- a) 保持警觉，当操作电动工具时关注所从事的操作并保持清醒。当你感到疲倦，或在有药物、酒精或治疗反应时，不要操作电动工具。
在操作电动工具时瞬间的疏忽会导致严重人身伤害。
- b) 使用个人防护装置。始终佩戴护目镜。
安全装置，诸如适当条件下使用防尘面具、防滑安全鞋、安全帽、听力防护等装置能减少人身伤害。
- c) 防止意外起动。确保开关在连接电源和 / 或电池盒、拿起或搬运工具时处于关断位置。
手指放在已接通电源的开关上或开关处于接通时插入插头可能会导致危险。
- d) 在电动工具接通之前，拿掉所有调节钥匙或扳手。
遗留在电动工具旋转零件上的扳手或钥匙会导致人身伤害。
- e) 手不要伸展得太长。时刻注意立足点和身体平衡。
这样在意外情况下能很好地控制电动工具。
- f) 着装适当。不要穿宽松衣服或佩戴饰品。让衣服、手套和头发远离运动部件。
宽松衣服、佩饰或长发可能会卷入运动部件中。
- g) 如果提供了与排屑、集尘设备连接用的装置，要确保它们连接完好且使用得当。
使用这些装置可减少尘屑引起的危险。

4) 电动工具使用和注意事项

- a) 不要滥用电动工具，根据用途使用适当的电动工具。
选用适当设计的电动工具会使你工作更有效、更安全。
- b) 如果开关不能接通或关断工具电源，则不能使用该电动工具。
不能用开关来控制的电动工具是危险的且必须进行修理。
- c) 在进行任何调节、更换附件或贮存电动工具之前，必须从电源上拔掉插头和 / 或使电池盒与工具脱开。
这种防护性措施将减少工具意外起动的危险。
- d) 将闲置不用的电动工具贮存在儿童所及范围之外，并且不要让不熟悉电动工具或对这些说明不了解的人操作电动工具。

中文

电动工具在未经培训的用户手中是危险的。

- e) 保养电动工具。检查运动件是否调整到位或卡住，检查零件破损情况和影响电动工具运行的其他状况。如有损坏，电动工具应在使用前修理好。许多事故由维护不良的电动工具引发。
- f) 保持切削刀具锋利和清洁。
保养良好的有锋利切削刃的刀具不易卡住而且容易控制。
- g) 按照使用说明书，考虑作业条件和进行的作业来使用电动工具、附件和工具的刀头等。
将电动工具用于那些与其用途不符的操作可能会导致危险。

5) 维修

- a) 将你的电动工具送交专业维修人员，使用同样的备件进行修理。
这样将确保所维修的电动工具的安全性。

注意！

不可让儿童和体弱人士靠近工作场所。

应将不使用的工具存放在儿童和体弱人士接触不到的地方。

砂磨、砂光或切割操作的通用安全警告

- a) 该电动工具是用于实现砂轮机、砂光机或切断工具功能的。请阅读随该电动工具提供的所有安全警告、说明、图解和规定。
不了解以下所列所有说明将导致电击、着火和 / 或严重伤害。
- b) 不推荐用该电动工具进行诸如、刷光、抛光或切断等操作。
电动工具不按指定的功能去操作，可能会发生危险和引起人身伤害。
- c) 不使用非工具制造商推荐和专门设计的附件。
否则该附件可能被装到你的电动工具上，而它不能保证安全操作。
- d) 附件的额定速度必须至少等于电动工具上标出的最大速度。
附件以比其额定速度大的速度运转会发生爆裂和飞溅。
- e) 附件的外径和厚度必须在电动工具额定能力范围之内。
不正确的附件尺寸不能得到充分防护或控制。
- f) 砂轮、法兰盘、靠背垫或任何其他附件的轴孔尺寸必须适合于安装到电动工具的主轴上。
带轴孔的、与电动工具安装件不配的附件将会失稳、过度振动并会引起失控。
- g) 不要使用损坏的附。在每次使用前要检查附件，例如砂轮是否有碎片和裂缝，靠背垫是否有的裂缝、撕裂或过度磨损，钢丝刷是否松动或金属丝是否断裂。如果电动工具或附件跌落了，检查是否有损坏或安装没有损坏的附件。检查和安装附件后，让自己和旁观者的位置远离旋转附件的平面，并以电动工具最大空载速度运行 1min。
损坏的附件通常在该试验时会碎裂。
- h) 戴上防护用品。根据适用情况，使用面罩、安全护目镜或安全眼镜。适用时，戴上防尘面具、听力保护器、手套和能挡小磨料或工件碎片的工作围裙。

眼防护罩必须挡住各种操作产生的飞屑。防尘面具或口罩必须能过滤操作产生的颗粒。长期暴露在高强度噪声中会引起失聪。

- i) 让旁观者与工作区域保持一安全距离。任何进入工作区域的人必须戴上防护用品。
工件或破损附件的碎片可能会飞出并引起紧靠着操作区域的旁观者的伤害。切割附件触及带电导线会使电动工具外露的金属零件带电，并使操作者触电。
- j) 当在切割附件有可能切割到暗线或自身电线的场所进行操作时，只能通过绝缘握持面来握住电动工具。
切割附件碰到一根带电导线可能会使电动工具的外露金属零件带电并使操作者发生电击危险。
- k) 使软线远离旋转的附件。
如果控制不当，软线可能被切断或缠绕，并使得你的手或手臂可能被卷入旋转附件中。
- l) 直到附件完全停止运动才放下电动工具。
旋转的附件可能会抓住表面并拉动电动工具而让你失去对工具的控制。
- m) 当携带电动工具时不要开动它。
意外地触及旋转附件可能会缠绕你的衣服而使附件伤害身体。
- n) 经常清理电动工具的通风口。
电动机风扇会将灰尘吸进机壳，过多的金属粉末沉积会导致电气危险。
- o) 不要在易燃材料附件操作电动工具。
火星可能会点燃这些材料。
- p) 不要使用需用冷却液的附件。
用水或其他冷却液可能会导致电腐蚀或电击。

反弹和相关警告

反弹是因卡住或缠绕住的旋转砂轮、靠背垫、钢丝刷或其他附件而产生的突然反作用力。卡住或缠绕会引起旋转附件的迅速堵转，随之使失控的电动工具在卡住点产生与附件旋转方向相反的运动。

例如，如果砂轮被工件缠绕或卡住，伸入卡住点的砂轮边缘可能会进入材料表面而引起砂轮爬出或反弹。砂轮可能飞向或飞离操作者，这取决于砂轮在卡住点的运动方向。在此条件下砂轮也可能碎裂。

反弹是电动工具误用和 / 或不正确操作工序或条件的结果，可以通过采取以下给出的适当预防措施得以避免。

- a) 保持紧握电动工具，使你的身体和手臂处于正确状态以抵抗反弹力。如有辅助手柄，则要一直使用，以便最大限度控制住起动时的反弹力或反力矩。
如采取合适的预防措施，操作者就可以控制反力矩或反弹力。
- b) 绝不能将手靠近旋转附件。
附件可能会反弹碰到手。

中文

- c) 不要站在发生反弹时电动工具可能移动到的地方。
反弹将在缠绕点驱使工具逆砂轮运动方向运动。
- d) 当在尖角、锐边等处作业时要特别小心。避免附件的弹跳和缠绕。
尖角、锐边和弹跳具有缠绕旋转附件的趋势并引起反弹的失控。
- e) 不要附装上锯链、木雕刀片或带齿锯片。
这些锯片会产生频繁的反弹和失控。

对磨削和金刚石砂轮切割操作的专用安全警告

- a) 只使用所推荐的砂轮型号和为选用砂轮专门设计的护罩。
不是为电动工具设计的砂轮不能充分得到防护，是不安全的。
- b) 护罩必须牢固地装在电动工具上，且放置得最具安全性，只有最小的砂轮部分暴露在操作人面前。
护罩帮助保护操作者免于受到爆裂砂轮碎片和偶然触及砂轮的危險。
- c) 砂轮只用作推荐的用途。例如：不要用切割砂轮的侧面进行磨削。
施加到砂轮侧面的力可能会使其碎裂。
- d) 始终为所选砂轮选用未损坏的、有恰当规格和形状的砂轮法兰盘。
合适的砂轮法兰盘支承砂轮可以减小砂轮破裂的可能性。切割砂轮的法兰盘可以不同于砂轮法兰盘。
- e) 不要使用从大规格电动工具上用剩的磨损砂轮。
用于大规格电动工具上的砂轮不适于较小规格工具的高速工况并可能会爆裂。

对金刚石砂轮切割操作的附加专用安全警告

- a) 不要“夹”住切割砂轮或施加过大的压力。
不要试图做过深的切割。
给砂轮施加过应力增加了砂轮在切割时的负载，容易缠绕或卡住，增加了反弹或砂轮爆裂的可能性。
- b) 身体不要对着旋转砂轮，也不要站在其后。
当把砂轮从操作者身边的操作点移开时，可能的反弹会使旋转砂轮和电动工具朝你推来。
- c) 当砂轮被卡住或无论任何原因而中断切割时，关掉电动工具并握住工具不要动，直到砂轮完全停止。
决不要试图当砂轮仍然运转时使切割砂轮脱离切割，否则会发生反弹。
调查并采取校正措施以消除砂轮卡住的原因。
- d) 不能在工件上重新启动切割操作。让砂轮达到全速后再小心地重新进入切割。
如果电动工具在工件上重新启动，砂轮可能会卡住，爬出或反弹。
- e) 支撑住板材或超大工件可使得砂轮卡住和反弹的危險降到最低限度。
大工件凭借自重而下垂。必须在工件靠近切割线处和砂轮两侧近工件边缘处放置支承。

- f) 当进行“盲切割”进入墙体或其他盲区时要格外小心。
伸出的砂轮可能会割到煤气管或水管，电线或由此引起反弹的物体。

砂光操作的专用安全警告

- a) 当砂光时，不要使用超大砂盘纸。选用砂盘纸时应按照制造商的推荐。
超出砂光垫盘的大砂盘纸有撕裂的危险并且会引起缠绕，砂盘的撕裂或反弹。



使用角向磨光机时的注意事项

1. 没有砂轮防护装置时千万不要使用本角向磨光机。
2. 只能使用“安全速度”至少与“13700 /s”同样高的砂轮。
3. 正确使用确保操作安全。
4. 安上标准磨轮。
5. 研磨开始之前应试车。
6. 应远离旋转的磨轮。
7. 严密注意打火花。
8. 不要将旋转的盘磨机放在地板上在无人照管的情况下离去。
9. 遵守使用说明书规定的磨轮更换步骤。
10. 防止过载操作。
11. 当主轴转动时不要撤下锁定销。
12. 操作时当心周围的人。

符号

警告！

如下所示的符号用于本机。使用前请务必理解其含意。

	为降低伤害风险，用户必须阅读使用说明书。
	始终戴好护目镜。

规格

电压	220V ~	
输入功率	560 W	
额定速度	12000 /min	
近砂轮尺寸	外径	100 mm
	厚度	4 mm, 6 mm
	内径	16 mm
重量（仅限于本体）	1.4 kg	

标准附件

除了主机（1 台）外，产品包中还包括表中所列的附件。

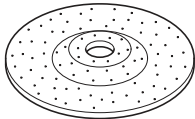
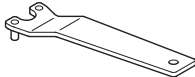
砂轮（人造的树脂黏结的砂轮） 外径 100 mm 厚度 4 mm 内径 16 mm		1
扳手		1

选购附件（分开销售）

注意！

一定要在有砂轮防护件时操作角向磨光机。

1. 装 100 mm 的砂盘

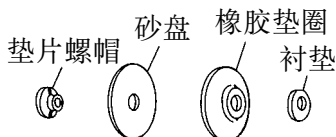

在对相当小的金属表面区抛光并期望得到特别细的抛光时，常用这种砂盘作相应突端的预抛光，以便去掉铁锈以及去除添增新制费的端点有 11 种砂盘，它们分别具有的粒度是 #16, #20, #24, #30, #36, #40, #50, #60, #80, #100, #120，当你提出要求时，请详细说明所希望的砂盘的粒度。

2. 金刚石砂轮装置

此装置常用于对混凝土、石头及瓷砖等的切割和画痕。

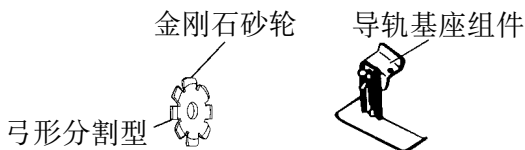

用途

- 用于去除铸品毛刺，飞边等物及抛光各种型号的钢、青铜、铝及铸造品。
- 研磨焊接部分或焊开的部分。
- 研磨砖块，大理石等等。
- 对混凝土、石头、瓷砖（用金刚石轮）进行切割和画痕。

作业之前

1. 电源
确认所使用的电源与工具铭牌上标示的规格是否相符。
2. 电源开关
确认电源开关是否切断。若电源开关接通，则插头插入电源插座时电动工具将出其不意地立刻转动，从而招致严重事故。
3. 延伸线缆
若作业场所移到离开电源的地点，应使用厚度足够、额定电容的延伸线缆，并且要尽可能地短些。
4. 确认环境条件
确认工作场地安排在符合规定措施的条件下。当研磨薄钢板时，因工作台的状态会产生很大的噪音，它是因为研磨钢板引起的。为了消除这种有害的噪音可在被研磨的材料下放一块橡皮垫。
5. 砂轮保护的安装
务请以一个角度安装轮保护装置，它将保护操作者的身体免受碎轮片的损伤。
6. 检查锁定销
在打开电源开关之前掀两、三下锁定销，检查锁定销是否被释放。
7. 砂轮的检查和安装
仔细检查所安装的砂轮确无破损和裂缝，确认所安装的砂轮在规定的条件下牢固地被夹持。
8. 试行运转
不检查砂轮上是否存在着破损和裂缝就开始研磨，将非常危险。所以在开始正式研磨之前使该角向磨光机在无人的情况下试行运转，如果没有问题，就表明此角向磨光机没有异常。
试运转的持续时间如下：
 当更换砂轮时3 分钟以上
 当开始日常工作前1 分钟以上

实用角向磨光机的应用

1. 压力
本机不可施加过大压力使其过载，这样才能延长机器的使用寿命并确保加工质量。在大部分的用法中，机器本身的重量即够研磨。加压过大将导致转速降低、表面加工不良以及过载，从而使机器寿命缩短。

中文

2. 研磨角度

切勿将砂轮的全表面施加于要研磨的材料上。如图 1 所示，机器应保持 $15 \sim 30^\circ$ ，使砂轮的外缘以最佳角度与工件相接触。

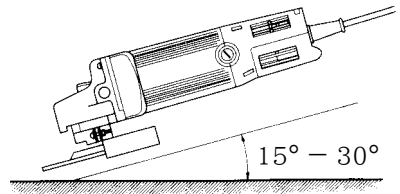

3. 用新砂轮首次进行研磨时，应将角向磨光机由对面横过工件往操作人员这边拉，以免挖人工件(图 1 的 B 方向)。

等砂轮的前缘适当磨损后，就可往任何方向进行研磨。

4. 若提供的砂轮(人造树脂黏结的砂轮)的额定粒度级是 A，粒度尺寸是 #36，因此，它的应用范围涉及面很广，事实证明它最适合于普通钢材的重研磨。因为这类钢材的的粒度大小相当粗糙要产生一个细的表面抛光是很困难的，在本例中轻轻地握住角向磨光机，提起它，慢慢地用一恒定的低速进行研磨，借此，可以得到与用细粒度砂轮时得到的细研磨相类似。

5. 角向磨光机的开关

开关是杠杆手柄式的，按它的开启(ON)端，开关就被接通，按它的关闭(OFF)端，开关就被断开。

6. 使用后的注意事项

使用后但在完全停止转动前，不要把角向磨光机立刻放在有许多细屑和污物和灰尘的地方。

注意！

○ 本机受到冲击时，会导致砂轮的破裂或发生裂痕。因此，在使用本机时，请留意勿使它受到冲击。

在使用本机前，不小心碰到或掉下本机时，请充分地检查一下砂轮是否有破裂或裂痕。

○ 本机在旋转时，请勿按下锁定销。如锁定销被按下的话，则请勿按下开关。

砂轮的装卸(图 2)

注意！

为了防备发生严重事故，必须关掉电源并将电源插头从插座中拔出。

(1) 把装置倒置使主轴朝上。

(2) 把垫片装到主轴上。

(3) 给砂轮的隆起部配装砂轮垫圈。

(4) 把砂轮螺帽的凸面装到砂轮上并且把螺帽拧到主轴上。

(5) 如图 2 所示，撤下锁定销防止主轴转动。用扳手拧紧砂轮螺帽卡紧磨轮。



图 2

注意！

确认砂轮安装是否牢固。

确认锁定销被解除锁定；可在打开电源开关之前通过揷二、三次锁定销进行检查。

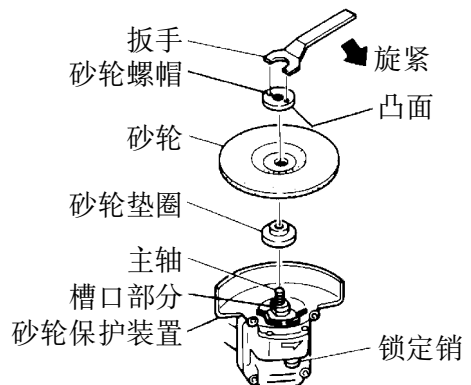
- 砂轮的拆卸和装配相反。

安装选配部件的方法

注意！

- 确认电源开关已断开并且电源插头没有接在电源插座上以避免严重事故，当使用选配附件时，要保证装上砂轮保护罩并且戴上眼镜。
- 不得使用其外径超过记载在选购附件上的外径的砂盘。

1. 安装 100 mm 的砂盘（参看图 3）

注：

不得利用砂轮的轮垫圈和轮螺帽。

- (1) 配上垫图，橡皮衬垫及砂盘到主轴上。
- (2) 旋垫圈螺帽到主轴。
- (3) 如图 3 所示，撤下锁定销防止主轴转动。用扳手拧紧砂轮螺帽卡紧砂盘。

2. 安装金刚石砂轮

注意！

使用金刚石砂轮时，要特别注意以下几点。

- (1) 使用正确尺寸的金刚石砂轮（外径 105 mm，内径 20 mm）
- (2) 使用金刚石砂轮时不要加凉水或磨削液。
- (3) 在切削操作中要牢固地握住工具以控制被材料所产生的反作用力。
- (4) 必须使切削深度保持在 2 ~ 5 mm 内，否则马达会过热而受损。请采用适度的切削速度，并请勿在工具上施加过大的压力。

- 安装导轨基座组件（图 4）

- (1) 松开砂轮保护装置上的两个小螺丝。
- (2) 在砂轮导轨和支架板（A）之间插入导轨片，并且上紧两个螺丝中的一个。请确认导轨确实不会活动。



图 3



图 4

中文

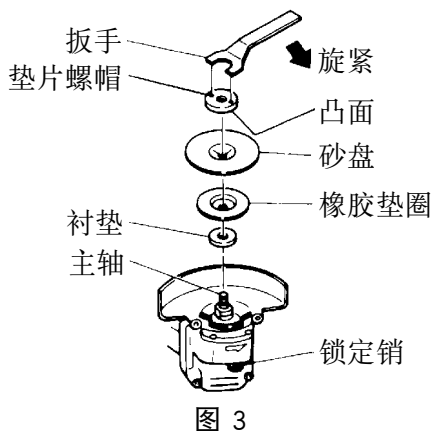
(3) 把砂轮保护装置装在适合于操作的位置，并牢固地拧紧另一个小螺丝以把砂轮保护装置固定在所定的位置上。

○ 安装金刚石砂轮 (图 5)

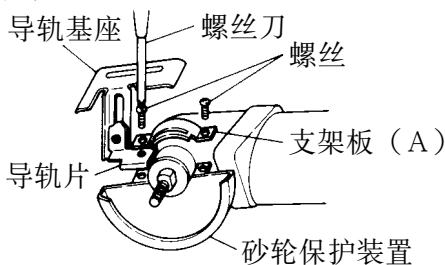
注：

按图 5 所示方法将金刚石砂轮安装在主轴上，注意砂轮垫圈和砂轮的通常用法相反。

(1) 把砂轮垫圈和金刚石砂轮安装在主轴上。

(2) 把砂轮螺帽的凸面安装在金刚石砂轮上，并把砂轮螺帽旋紧主轴。

(3) 按图 5 所示方法，按下锁定销以防止主轴转动。用扳手拧紧砂轮螺帽以卡紧金刚石砂轮。



图 5



图 6

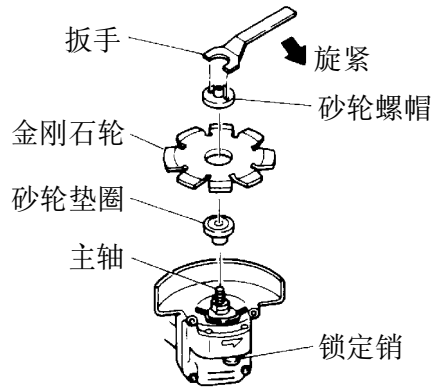

图 7

维护和检查

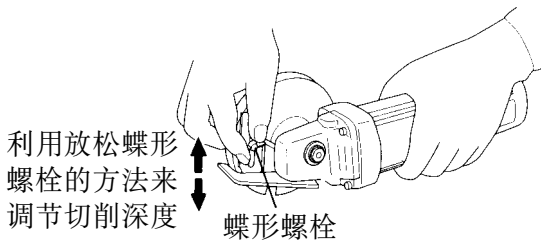
1. 检查砂轮

检查砂轮确无破裂和表面缺陷。

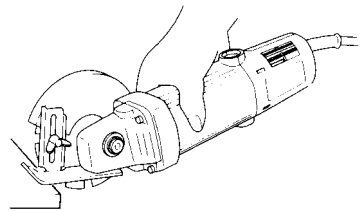
当砂轮外径被磨损 60 mm 时要更换砂轮。

2. 检查安装螺钉

要经常检查安装螺钉是否紧固妥善。若发现螺钉松了，应立即重新扭紧，否则会导致严重的事故。

3. 检查炭刷 (图 8)

电动机上的炭刷是一种消耗品，其磨损程度一旦超出了“磨损极限”，电动机将发生故障。因此，磨损了的炭刷应即更换新件。此外，炭刷必需常保干净状态，这样才能在刷握里自由滑动。

4. 炭刷的更换

用一字形头螺丝刀拆卸刷盖、炭刷就可简单地取下。



图 8

5. 电动机的维护

电动机绕线是电动工具的“心脏部”。应仔细检查有无损伤，是否被油液或水沾湿。

6. 更换电源线

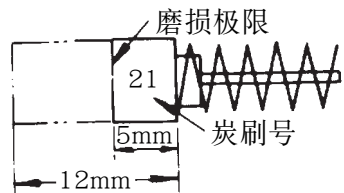
必须更换电源线时，应由HiKOKI公司授权的维修中心来更换，以避免安全危险。

本电动工具的电源线损坏时必须更换成由维修组织特别准备的电源线。

7. 维修零部件一览表

注意！

HiKOKI牌电动工具的维修、改造和检查须由经HiKOKI公司授权的维修中心进行。

当要求维修或其他保养服务时，若将此零部件一览表与电动工具一起呈交给经HiKOKI公司授权的维修中心，将有助于维修或保养工作。

在操作和维修电动工具时，必须遵守贵国制定的安全的有关规则和标准。

维修零部件一览表

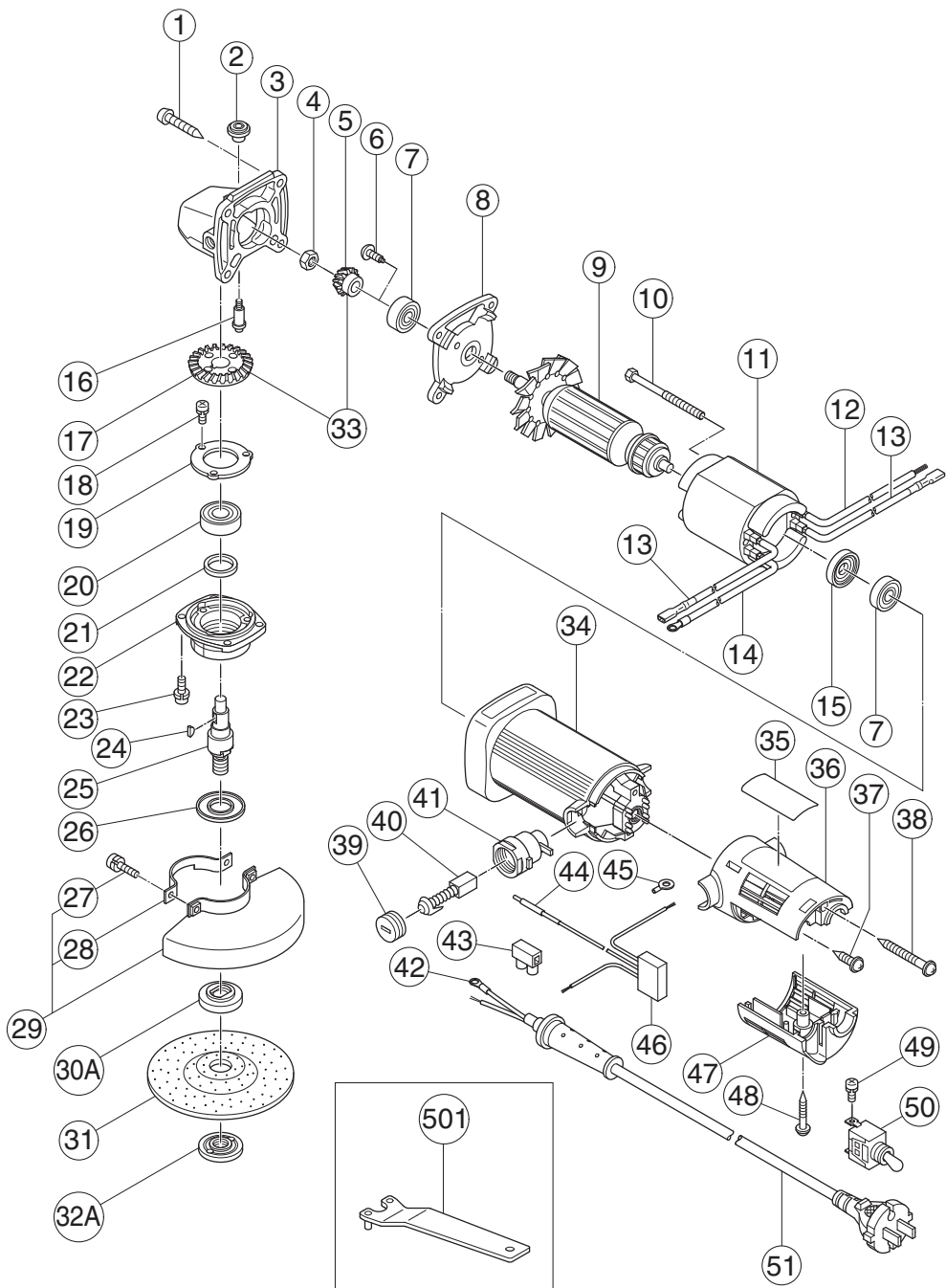

项目号	代码号	使用数	备注	项目号	代码号	使用数	备注
1	937807	4	D5x25	42	980063	1	
2	301944	1		43	938307	1	
3	303078	1	"2, 16"	44	314854	1	
4	301941	1	M7	45	980063	1	
5	301939	1		46	994273	1	
6	301936	2	M4x10	47	320272	1	
7	608VVM	2	608VVC2PS2L	48	304035	1	D4x25
8	301935	1		49	305499	2	M3.5x6
9	360464E	1		50	955509	1	
10	963712	2	D4x65	51	315879	1	
11	340428E	1		501	313933	1	
12	320273	1	70L				
13	320274	2	85L				
14	320275	1	60L				
15	315877	1					
16	301943	1					
17	301940	1					
18	997263	3	M4x10				
19	938058	1					
20	6001VV	1	6001VVCMP2L				
21	301946	1					
22	301947	1					
23	307127	4	M4x12				
24	940220	1	2.5x8				
25	302046	1					
26	301945	1					
27	308386	2	M5x16				
28	301949	1					
29	301948	1	"27, 28"				
30A	320497	1					
31	316820	1	100MMX4T A36Q				
32A	321795	1					
33	301938	1	"5, 17"				
34	320271	1					
35	——	1					
36	320276	1					
37	302086	1	D4x20				
38	306664	1	D4x40				
39	936551	2					
40	999021	2					
41	313777	2					

CONTENTS

GENERAL POWER TOOL SAFETY WARNINGS	16
SAFETY WARNINGS COMMON FOR GRINDING, SANDING OR CUTTING-OFF OPERATIONS	18
KICKBACK AND RELATED WARNINGS	20
SAFETY WARNINGS SPECIFIC FOR GRINDING AND DIAMOND WHEEL CUTTING-OFF OPERATIONS	21
ADDITIONAL SAFETY WARNINGS SPECIFIC FOR DIAMOND WHEEL CUTTING-OFF OPERATIONS	21
SAFETY WARNINGS SPECIFIC FOR SANDING OPERATIONS	22
PRECAUTIONS ON USING DISC GRINDER.....	22
SYMBOLS	22
SPECIFICATIONS	23
STANDARD ACCESSORIES	23
OPTIONAL ACCESSORIES (sold separately).....	23
APPLICATIONS.....	24
PRIOR TO OPERATION.....	24
PRACTICAL GRINDER APPLICATION	25
ASSEMBLING AND DISASSEMBLING THE DEPRESSED CENTER WHEEL	26
HOW TO INSTALL THE OPTIONAL ACCESSORIES.....	26
MAINTENANCE AND INSPECTION	28
SERVICE PARTS LIST	30

GENERAL POWER TOOL SAFETY WARNINGS

WARNING

Read all safety warnings and all instructions.

Failure to follow the warnings and instructions may result in electric shock, fire and/or serious injury.

Save all warnings and instructions for future reference.

The term “power tool” in the warnings refers to your mains-operated (corded) power tool or battery-operated (cordless) power tool.

- 1) **Work area safety**
 - a) **Keep work area clean and well lit.**
Cluttered or dark areas invite accidents.
 - b) **Do not operate power tools in explosive atmospheres, such as in the presence of flammable liquids, gases or dust.**
Power tools create sparks which may ignite the dust or fumes.
 - c) **Keep children and bystanders away while operating a power tool.**
Distractions can cause you to lose control.

2) **Electrical safety**

- a)
- Power tool plugs must match the outlet.**

Never modify the plug in any way.

Do not use any adapter plugs with earthed (grounded) power tools.

Unmodified plugs and matching outlets will reduce risk of electric shock.

- b)
- Avoid body contact with earthed or grounded surfaces, such as pipes, radiators, ranges and refrigerators.**

There is an increased risk of electric shock if your body is earthed or grounded.

- c)
- Do not expose power tools to rain or wet conditions.**

Water entering a power tool will increase the risk of electric shock.

- d)
- Do not abuse the cord. Never use the cord for carrying, pulling or unplugging the power tool.**

Keep cord away from heat, oil, sharp edges or moving parts.

Damaged or entangled cords increase the risk of electric shock.

- e)
- When operating a power tool outdoors, use an extension cord suitable for outdoor use.**

Use of a cord suitable for outdoor use reduces the risk of electric shock.

- f)
- If operating a power tool in a damp location is unavoidable, use a residual current device (RCD) protected supply.**

Use of an RCD reduces the risk of electric shock.

3) **Personal safety**

- a)
- Stay alert, watch what you are doing and use common sense when operating a power tool.**

Do not use a power tool while you are tired or under the influence of drugs, alcohol or medication.

A moment of inattention while operating power tools may result in serious personal injury.

- b)
- Use personal protective equipment. Always wear eye protection.**

Protective equipment such as dust mask, non-skid safety shoes, hard hat, or hearing protection used for appropriate conditions will reduce personal injuries.

- c)
- Prevent unintentional starting. Ensure the switch is in the off position before connecting to power source and/or battery pack, picking up or carrying the tool.**

Carrying power tools with your finger on the switch or energising power tools that have the switch on invites accidents.

- d)
- Remove any adjusting key or wrench before turning the power tool on.**

A wrench or a key left attached to a rotating part of the power tool may result in personal injury.

- e)
- Do not overreach. Keep proper footing and balance at all times.**

This enables better control of the power tool in unexpected situations.

- f)
- Dress properly. Do not wear loose clothing or jewellery. Keep your hair, clothing and gloves away from moving parts.**

Loose clothes, jewellery or long hair can be caught in moving parts.

- g)
- If devices are provided for the connection of dust extraction and collection facilities, ensure these are connected and properly used.**

English

Use of dust collection can reduce dust-related hazards.

4) Power tool use and care

- a) **Do not force the power tool. Use the correct power tool for your application.**
The correct power tool will do the job better and safer at the rate for which it was designed.
- b) **Do not use the power tool if the switch does not turn it on and off.**
Any power tool that cannot be controlled with the switch is dangerous and must be repaired.
- c) **Disconnect the plug from the power source and/or the battery pack from the power tool before making any adjustments, changing accessories, or storing power tools.**
Such preventive safety measures reduce the risk of starting the power tool accidentally.
- d) **Store idle power tools out of the reach of children and do not allow persons unfamiliar with the power tool or these instructions to operate the power tool.**
Power tools are dangerous in the hands of untrained users.
- e) **Maintain power tools. Check for misalignment or binding of moving parts, breakage of parts and any other condition that may affect the power tool's operation.**
If damaged, have the power tool repaired before use.
Many accidents are caused by poorly maintained power tools.
- f) **Keep cutting tools sharp and clean.**
Properly maintained cutting tools with sharp cutting edges are less likely to bind and are easier to control.
- g) **Use the power tool, accessories and tool bits etc. in accordance with these instructions, taking into account the working conditions and the work to be performed.**
Use of the power tool for operations different from those intended could result in a hazardous situation.

5) Service

- a) **Have your power tool serviced by a qualified repair person using only identical replacement parts.**
This will ensure that the safety of the power tool is maintained.

CAUTION

Keep children and infirm persons away.

When not in use, tools should be stored out of reach of children and infirm persons.

SAFETY WARNINGS COMMON FOR GRINDING, SANDING OR CUTTING-OFF OPERATIONS

- a) **This power tool is intended to function as a grinder, sander or cut-off tool. Read all safety warnings, instructions, illustrations and specifications provided with this power tool.**
Failure to follow all instructions listed below may result in electric shock, fire and/or serious injury.

- b) **Operations such as polishing, wire brushing or abrasive cutting-off are not recommended to be performed with this power tool.**
Operations for which the power tool was not designed may create a hazard and cause personal injury.
- c) **Do not use accessories which are not specifically designed and recommended by the tool manufacturer.**
Just because the accessory can be attached to your power tool, it does not assure safe operation.
- d) **The rated speed of the accessory must be at least equal to the maximum speed marked on the power tool.**
Accessories running faster than their rated speed can break and fly apart.
- e) **The outside diameter and the thickness of your accessory must be within the capacity rating of your power tool.**
Incorrectly sized accessories cannot be adequately guarded or controlled.
- f) **The arbour size of wheels, flanges, backing pads or any other accessory must properly fit the spindle of the power tool.**
Accessories with arbour holes that do not match the mounting hardware of the power tool will run out of balance, vibrate excessively and may cause loss of control.
- g) **Do not use a damaged accessory. Before each use inspect the accessory such as abrasive wheels for chips and cracks, backing pad for cracks, tear or excess wear, wire brush for loose or cracked wires. If power tool or accessory is dropped, inspect for damage or install an undamaged accessory. After inspecting and installing an accessory, position yourself and bystanders away from the plane of the rotating accessory and run the power tool at maximum no-load speed for one minute.**
Damaged accessories will normally break apart during this test time.
- h) **Wear personal protective equipment. Depending on application, use face shield, safety goggles or safety glasses. As appropriate, wear dust mask, hearing protectors, gloves and workshop apron capable of stopping small abrasive or workpiece fragments.**
The eye protection must be capable of stopping flying debris generated by various operations. The dust mask or respirator must be capable of filtering particles generated by your operation. Prolonged exposure to high intensity noise may cause hearing loss.
- i) **Keep bystanders a safe distance away from work area. Anyone entering the work area must wear personal protective equipment.**
Fragments of workpiece or of a broken accessory may fly away and cause injury beyond immediate area of operation.
- j) **Hold power tool by insulated gripping surfaces only, when performing an operation where the cutting accessory may contact hidden wiring or its own cord.**
Cutting accessory contacting a "live" wire may make exposed metal parts of the power tool "live" and shock the operator.
- k) **Position the cord clear of the spinning accessory.**
If you lose control, the cord may be cut or snagged and your hand or arm may be pulled into the spinning accessory.

English

- l) **Never lay the power tool down until the accessory has come to a complete stop.**
The spinning accessory may grab the surface and pull the power tool out of your control.
- m) **Do not run the power tool while carrying it at your side.**
Accidental contact with the spinning accessory could snag your clothing, pulling the accessory into your body.
- n) **Regularly clean the power tool's air vents.**
The motor's fan will draw the dust inside the housing and excessive accumulation of powdered metal may cause electrical hazards.
- o) **Do not operate the power tool near flammable materials.**
Sparks could ignite these materials.
- p) **Do not use accessories that require liquid coolants.**
Using water or other liquid coolants may result in electrocution or shock.

KICKBACK AND RELATED WARNINGS

Kickback is a sudden reaction to a pinched or snagged rotating wheel, backing pad or any other accessory. Pinching or snagging causes rapid stalling of the rotating accessory which in turn causes the uncontrolled power tool to be forced in the direction opposite of the accessory's rotation at the point of the binding.

For example, if an abrasive wheel is snagged or pinched by the workpiece, the edge of the wheel that is entering into the pinch point can dig into the surface of the material causing the wheel to climb out or kick out. The wheel may either jump toward or away from the operator, depending on direction of the wheel's movement at the point of pinching. Abrasive wheels may also break under these conditions.

Kickback is the result of power tool misuse and/or incorrect operating procedures or conditions and can be avoided by taking proper precautions as given below.

- a) **Maintain a firm grip on the power tool and position your body and arm to allow you to resist kickback forces. Always use auxiliary handle, if provided, for maximum control over kickback or torque reaction during start-up.**
The operator can control torque reactions or kickback forces, if proper precautions are taken.
- b) **Never place your hand near the rotating accessory.**
Accessory may kickback over your hand.
- c) **Do not position your body in the area where power tool will move if kickback occurs.**
Kickback will propel the tool in direction opposite to the wheel's movement at the point of snagging.
- d) **Use special care when working corners, sharp edges etc. Avoid bouncing and snagging the accessory.**
Corners, sharp edges or bouncing have a tendency to snag the rotating accessory and cause loss of control or kickback.
- e) **Do not attach a saw chain woodcarving blade or toothed saw blade.**
Such blades create frequent kickback and loss of control.

SAFETY WARNINGS SPECIFIC FOR GRINDING AND DIAMOND WHEEL CUTTING-OFF OPERATIONS

- a) **Use only wheel types that are recommended for your power tool and the specific guard designed for the selected wheel.**
Wheels for which the power tool was not designed cannot be adequately guarded and are unsafe.
- b) **The guard must be securely attached to the power tool and positioned for maximum safety, so the least amount of wheel is exposed towards the operator.**
The guard helps to protect operator from broken wheel fragments and accidental contact with wheel.
- c) **Wheels must be used only for recommended applications. For example: do not grind with the side of cut-off wheel.**
Abrasive cut-off wheels are intended for peripheral grinding, side forces applied to these wheels may cause them to shatter.
- d) **Always use undamaged wheel flanges that are of correct size and shape for your selected wheel.**
Proper wheel flanges support the wheel thus reducing the possibility of wheel breakage. Flanges for cut-off wheels may be different from grinding wheel flanges.
- e) **Do not use worn down wheels from larger power tools.**
Wheel intended for larger power tool is not suitable for the higher speed of a smaller tool and may burst.

ADDITIONAL SAFETY WARNINGS SPECIFIC FOR DIAMOND WHEEL CUTTING-OFF OPERATIONS

- a) **Do not “jam” the cut-off wheel or apply excessive pressure. Do not attempt to make an excessive depth of cut.**
Overstressing the wheel increases the loading and susceptibility to twisting or binding of the wheel in the cut and the possibility of kickback or wheel breakage.
- b) **Do not position your body in line with and behind the rotating wheel.**
When the wheel, at the point of operation, is moving away from your body, the possible kickback may propel the spinning wheel and the power tool directly at you.
- c) **When wheel is binding or when interrupting a cut for any reason, switch off the power tool and hold the power tool motionless until the wheel comes to a complete stop. Never attempt to remove the cut-off wheel from the cut while the wheel is in motion otherwise kickback may occur.**
Investigate and take corrective action to eliminate the cause of wheel binding.
- d) **Do not restart the cutting operation in the workpiece. Let the wheel reach full speed and carefully reenter the cut.**
The wheel may bind, walk up or kickback if the power tool is restarted in the workpiece.
- e) **Support panels or any oversized workpiece to minimize the risk of wheel pinching and kickback.**
Large workpieces tend to sag under their own weight. Supports must be placed under the workpiece near the line of cut and near the edge of the workpiece on both sides of the wheel.

English

- f) **Use extra caution when making a “pocket cut” into existing walls or other blind areas.**
The protruding wheel may cut gas or water pipes, electrical wiring or objects that can cause kickback.

SAFETY WARNINGS SPECIFIC FOR SANDING OPERATIONS

- a) **Do not use excessively oversized sanding disc paper. Follow manufacturers recommendations, when selecting sanding paper.**
Larger sanding paper extending beyond the sanding pad presents a laceration hazard and may cause snagging, tearing of the disc or kickback.



PRECAUTIONS ON USING DISC GRINDER

1. Never operate this power tool without Wheel Guard.
2. Use only depressed center wheels with a “Safe Speed” at least high as 13700/min.
3. Correct use for safe operation.
4. Mount the standard depressed center wheel.
5. Have a trial run before grinding commence.
6. Keep away from a revolving depressed center wheel.
7. Pay strict attention to sparks.
8. Do not leave the revolving Grinder unattended on the floor.
9. Follow the procedures of these Handling Instructions on depressed center wheel replacement.
10. Avoid overload operation.
11. Do not push in the lock pin while the spindle is running.
12. Be careful those around one while operating.

SYMBOLS

WARNING

The following show symbols used for the machine. Be sure that you understand their meaning before use.

	To reduce the risk of injury, user must read instruction manual.
	Always wear eye protection.

SPECIFICATIONS

Voltage	220 V ~	
Power Input	560 W	
Rated speed	12000 /min	
Wheel size	External dia.	100 mm
	Thickness	4 mm, 6 mm
	Internal dia.	16 mm
Weight (Only main body)	1.4 Kg	

STANDARD ACCESSORIES

In addition to the main unit (1 unit), the package contains the accessories listed in the below.

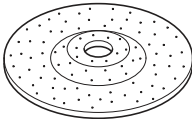
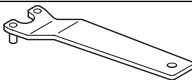
Depressed center wheel (Resinoid Wheel) external dia. 100 mm thickness 4 mm Internal dia. 16 mm		1
Wrench		1

OPTIONAL ACCESSORIES (sold separately)

CAUTION

Always operate the grinder with the wheel guard attached.

1. 100 mm Sanding Disc Set

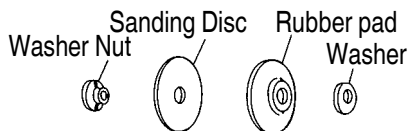

In case when only a relatively small metal surface area is to be polished and it is desired to give it a particularly fine finish, this is used for preliminary polishing of the metal surface before applying point, for removing rust, and for removing point when a new test is to be applied.

There are eleven different kinds of sanding discs, having grains of #16, #20, #24, #30, #36, #40, #50, #60, #80, #100, #120. When placing your order, please specify the grain of the disc desired.

English

2. Diamond Wheel Set

This is used for cutting and scribing of concrete, stone, tile etc.

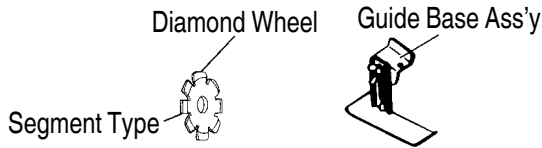

APPLICATIONS

- Removal of casting fin and finishing of various types of steel, bronze and aluminum materials and castings.
- Grinding of welded sections or sections cut by means of a acetylene torch.
- Grinding of brick, marble, etc.
- Cutting and scribing of concrete, stone, tile. (use the diamond wheel)

PRIOR TO OPERATION

1. Power source
Ensure that the power source to be utilized conforms to the power requirements specified on the product nameplate.
2. Power switch
Ensure that the power switch is in the OFF position. If the plug is connected to a receptacle while the power switch is in the ON position, the power tool will start operating immediately, which could cause a serious accident.
3. Extension cord
When the work area is removed from the power source, use an extension cord of sufficient thickness and rated capacity. The extension cord should be kept as short as practicable.
4. Confirming condition of the environment
Confirm that the work site is placed under appropriate conditions conforming to prescribed precautions.
When grinding a thin steel plate, depending upon the state of the workbench, a loud noise will be created due to resounding noise from the steel plate being ground. To eliminate unwanted noise in this instance, place a rubber mat beneath the material to be ground.
5. Mounting the wheel guard
Be sure to mount the wheel guard at an angle that will protect the operator's body from injury by a broken wheel piece.
6. Confirm the lock pin
Confirm that the lock pin is disengaged by pushing lock pin two or three times before switching the power tool on.
7. Confirming and mounting the depressed center wheel
Thoroughly check that a specified depressed center wheel is free of cracks and splits is mounted.
Confirm that the depressed center wheel is mounted under the specified condition and is firmly clamped.
For details, refer to the item "Assembling and Disassembling the depressed center wheel."

8. Apply a trial run

To start grinding work without checking for possible cracks and splits in the depressed center wheel is very dangerous. Prior to start of grinding, direct the grinder in a direction where no one is present, and apply a trial run without fail to confirm that the grinder displays no abnormalities.

Duration of the trial run is as follows:

When depressed center wheels is replaced 3 minutes or more

When starting daily work..... 1 minute or more

PRACTICAL GRINDER APPLICATION

1. Pressure

To prolong the life of the machine and ensure a first class finish, it is important that the machine should not be overloaded by applying too much pressure. In most applications, the weight of the machine alone is sufficient for effective grinding. Too much pressure will result in reduced rotational speed, inferior surface finish, and overloading which could reduce the life of the machine.

2. Grinding angle

Do not apply the entire surface of the depressed center wheel to the material to be ground. As shown in **Fig. 1**, the machine should be held at an angle of $15^{\circ} - 30^{\circ}$ so that the external edge of the depressed center wheel contacts the material at an optimum angle.

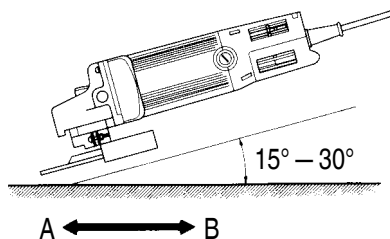

Fig. 1

3. To prevent a new depressed center wheel from digging into the workpiece, initial grinding should be performed by drawing the grinder across the workpiece toward the operator (**Fig. 1 direction B**).

Once the leading edge of the depressed center wheel is properly abraded, grinding may be conducted in either direction.

4. The provided depressed center wheel (resinoid wheel) is rated as class A grain and #36 grain size.

Accordingly, its range of applications cover a wide variety, proving to be most suitable for heavy grinding of general steel materials. Since the wheel grain size is rather coarse, creating a fine-surfaced finish is very difficult.

In this instance, hold the grinder lightly as though trying to lift it, and apply grinding slowly at a constant low speed, whereby a fine finish similar to that accomplished with a fine-grain depressed center wheel is obtainable.

5. Switching on the grinder

The switch can be turned ON by turning its lever ON side, or turn OFF by turning its lever to the OFF side.

6. Precaution after use

Do not lay the grinder down immediately after using in a place where there are many shavings and much dirt and dust until it has completely stopped revolving.

English

CAUTION

- Shock to the main body can be the cause of cracks or splits in the depressed center wheel. Be especially careful to avoid sudden shocks when using the grinder. If the grinder is accidentally bumped or dropped, make a careful check for cracks or splits on the depressed center wheel before further use.
- Do not press the lock pin when the grinder is turning. Also, do not turn on the switch when the lock pin is pressed down.

ASSEMBLING AND DISASSEMBLING THE DEPRESSED CENTER WHEEL (Fig. 2)

CAUTION

Be sure to switch OFF and disconnect the attachment plug from the receptacle to avoid a serious accident.

- (1) Turn the equipment upsidedown so that the spindle will be facing up.
- (2) Mount the wheel washer onto the spindle.
- (3) Mount the protuberance of the depressed center wheel onto the wheel washer.
- (4) Mount the convex side of the wheel nut onto the depressed center wheel, and screw the wheel nut onto the spindle.
- (5) As shown in Fig. 2, push in the lock pin to prevent rotation of the spindle. Then, secure the depressed center wheel by tightening the wheel nut with the wrench.

CAUTION

Confirm that the depressed center wheel is mounted firmly. Confirm that the lock pin is disengaged by pushing lock pin two or three times before switching the power tool on.

- Disassembling of the depressed center wheel is the reverse of assembling.

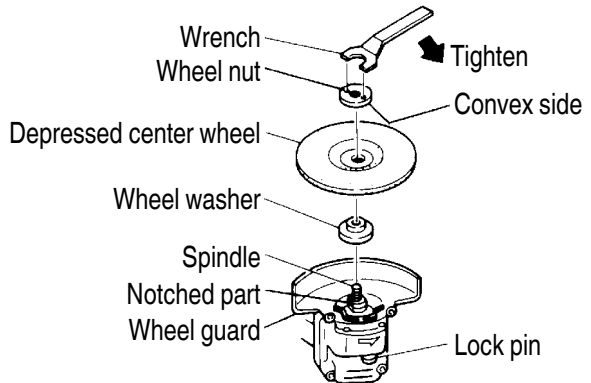

Fig. 2

HOW TO INSTALL THE OPTIONAL ACCESSORIES

CAUTION

- Be sure to switch power OFF and disconnect the plug from the power receptacle to avoid serious trouble. When utilizing the optional accessories, keep the wheel guard attached and wear protective glasses.
- Do not use the optional accessories which exceed the designated external diameter designated in the paragraph.

1. Mounting the 100 mm Sanding Disc. (see Fig. 3)

NOTE

Do not use the wheel washer and wheel nut of the depressed center wheel.

- (1) Mount the washer, rubber pad and sanding disc onto the spindle.
 - (2) Screw from the washer nut onto the spindle.
 - (3) As shown in Fig. 3, push in the lock pin to prevent rotation of the spindle. Then, secure the sanding disc by tightening the wheel nut with the wrench.
2. Mounting the Diamond Wheel

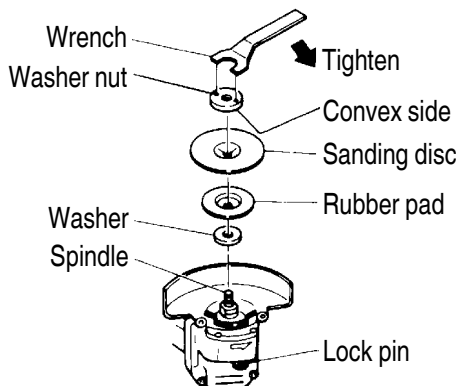

Fig. 3

CAUTION

When utilizing the diamond wheel, pay particular attention to the following points.

- (1) Utilize the correct size diamond wheel (external dia. 105 mm, Internal dia. 20 mm).
- (2) Do not apply cooling water or grinding fluid while utilizing the diamond wheel.
- (3) Hold the grinder firmly to control the tendency of the grinder to be rebounded from the material during cutting operation.
- (4) Ensure that the cutting depth is kept within 2-5 mm to prevent over-heating damage to the motor. Use with moderate cutting speed, and do not apply excessive pressure on the workpiece.

- Mounting the Guide Base Assembly. (Fig. 4)

- (1) Loosen the two small screws on the wheel guard.
- (2) Insert the guide piece between the wheel guard and set plate (A), and tighten one of the small screws. Ensure that the guide will not move.
- (3) Set the angle of the wheel guard to a suitable position for operation, and securely tighten the remaining small screw to fix the wheel guard in position.

- Mounting the Diamond Wheel. (Fig. 5)

NOTE

Mounting of the diamond wheel on the spindle is illustrated in Fig. 5. Note that the wheel washer is reversed from ordinary usage with depressed center wheel.

- (1) Mount the wheel washer and diamond wheel onto the spindle.
- (2) Mount the concave side of the wheel nut onto the diamond wheel, and screw the wheel nut onto the spindle.

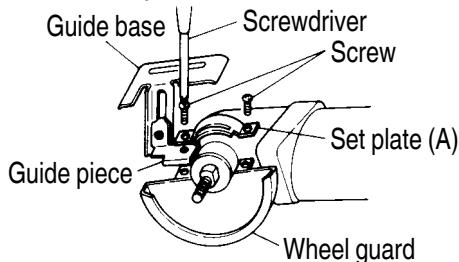

Fig. 4

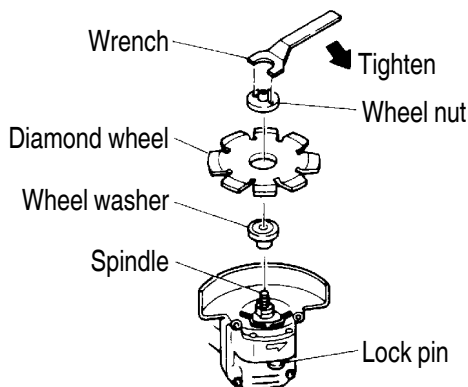

Fig. 5

English

- (3) As shown in **Fig. 5 on page 27**, push in the lock pin to prevent rotation of the spindle. Then, secure the diamond wheel by tightening the wheel nut with the wrench.

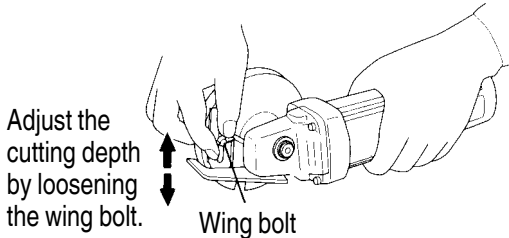

Fig. 6

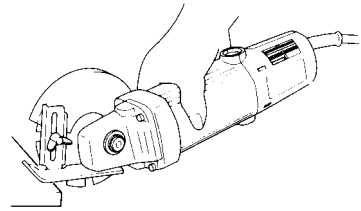

Fig. 7

MAINTENANCE AND INSPECTION

- 1. Inspecting the depressed center wheel**
Ensure that the depressed center wheel is free of cracks and surface defects. Replace the depressed center wheel when it has been worn out to about 60 mm in external diameter.
- 2. Inspecting the mounting screws**
Regularly inspect all mounting screws and ensure that they are properly tightened. Should any of the screws be loose, retighten them immediately. Failure to do so could result in serious hazard.
- 3. Inspecting the carbon brushes (Fig. 8)**
The motor employs carbon brushes which are consumable parts. Since an excessively worn carbon brush can result in motor trouble, replace the carbon brushes with new ones having the same carbon brush No. shown in the figure when it becomes worn to or near the “wear limit”. In addition, always keep carbon brushes clean and ensure that they slide freely within the brush holders.
- 4. Replacing carbon brushes**
Disassemble the brush caps with a slotted-head screwdriver. The carbon brushes can then be easily removed.
- 5. Maintenance of the motor**
The motor unit winding is the very “heart” of the power tool. Exercise due care to ensure the winding does not become damaged and/or wet with oil or water.
- 6. Replacing supply cord**
If the replacement of the supply cord is necessary, this has to be done by HiKOKI Authorized Service Center in order to avoid a safety hazard. If the supply cord of this power tool is damaged, it must be replaced by a specially prepared cord available through the service organization.

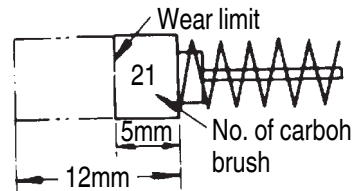

Fig. 8

7. Service parts list

CAUTION

Repair, modification and inspection of HiKOKI Power Tools must be carried out by a HiKOKI Authorized Service Center.

This Parts List will be helpful if presented with the tool to the HiKOKI Authorized Service Center when requesting repair or other maintenance.

In the operation and maintenance of power tools, the safety regulations and standards prescribed in each country must be observed.

SERVICE PARTS LIST

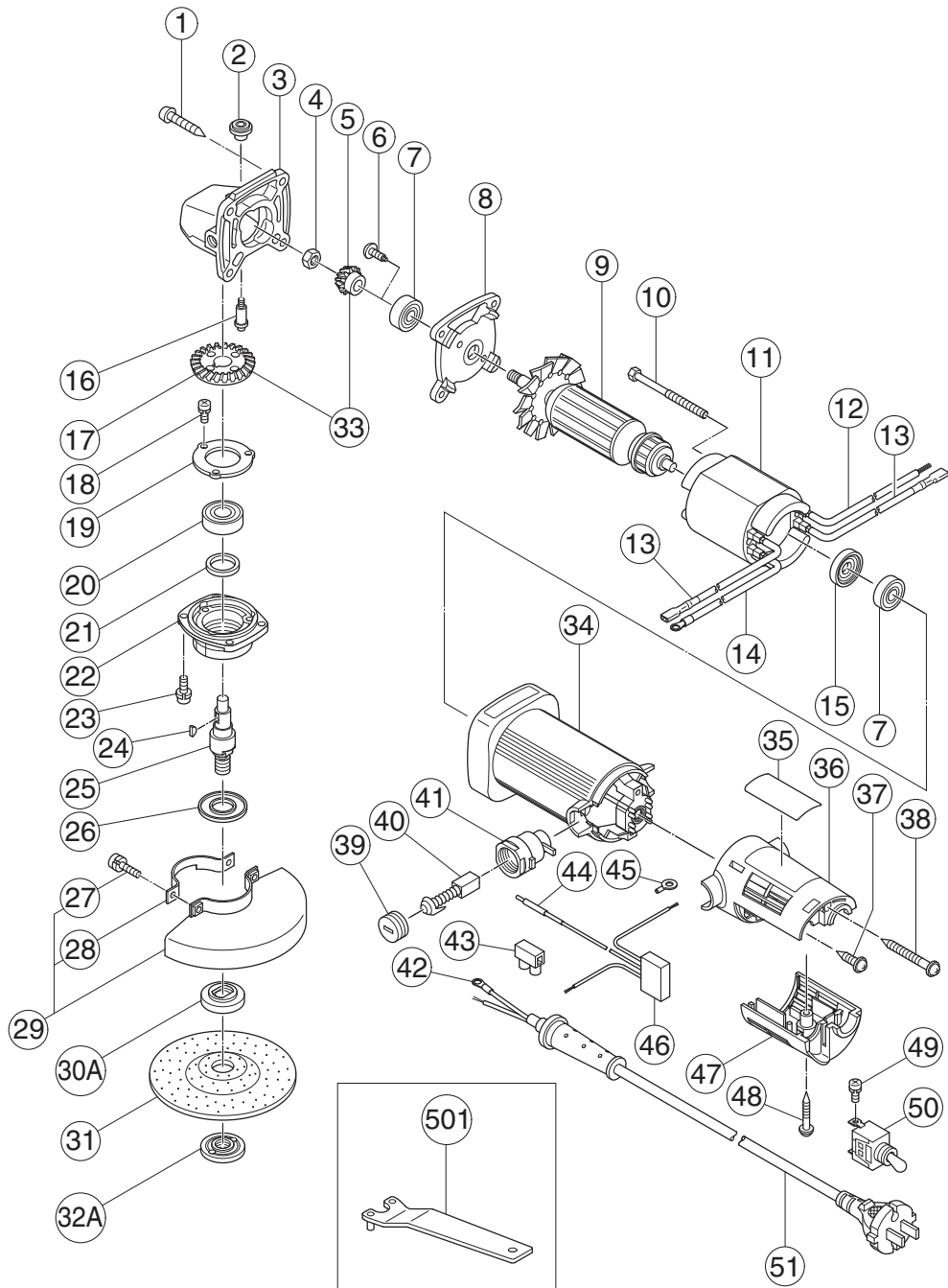

Item No.	Code No.	No. Used	Remarks	Item No.	Code No.	No. Used	Remarks
1	937807	4	D5x25	41	313777	2	
2	301944	1		42	980063	1	
3	303078	1	"2, 16"	43	938307	1	
4	301941	1	M7	44	314854	1	
5	301939	1		45	980063	1	
6	301936	2	M4x10	46	994273	1	
7	608VVM	2	608VVC2PS2L	47	320272	1	
8	301935	1		48	304035	1	D4x25
9	360464E	1		49	305499	2	M3.5x6
10	963712	2	D4x65	50	955509	1	
11	340428E	1		51	315879	1	
12	320273	1	70L	501	313933	1	
13	320274	2	85L				
14	320275	1	60L				
15	315877	1					
16	301943	1					
17	301940	1					
18	997263	3	M4x10				
19	938058	1					
20	6001VV	1	6001VVCMP2L				
21	301946	1					
22	301947	1					
23	307127	4	M4x12				
24	940220	1	2.5x8				
25	302046	1					
26	301945	1					
27	308386	2	M5x16				
28	301949	1					
29	301948	1	"27, 28"				
30A	320497	1					
31	316820	1	100MMX4T A36Q				
32A	321795	1					
33	301938	1	"5, 17"				
34	320271	1					
35	_____	1					
36	320276	1					
37	302086	1	D4x20				
38	306664	1	D4x40				
39	936551	2					
40	999021	2					

服务中心
高壹工机商业(上海)有限公司
上海市闵行区浦江工业园区三鲁路3585号7幢3楼

制造商
福建高壹工机有限公司
福建省福州市福兴投资区湖塘路

Koki Holdings Co., Ltd.

107
编号: C99107829 F
发行日期: 2021年 7月
中国印刷