

HiKOKI

电钻

Drill

中文

English

FD 10SA • FD 10VA

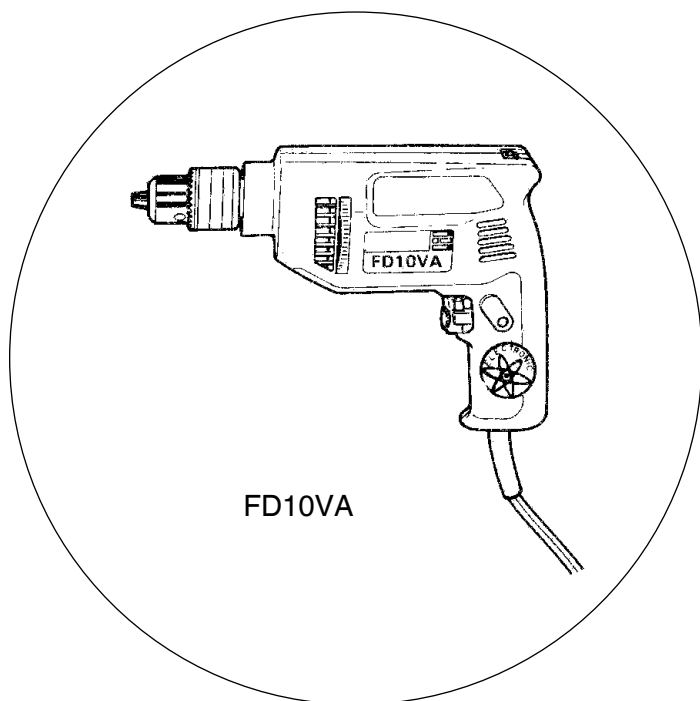

保留备用

Keep for future reference



使用说明书

Handling instructions



目次

电动工具通用安全警告	2	用途.....	6
电钻安全警告.....	4	作业之前	6
使用电钻时应注意事项.....	4	使用方法.....	6
符号.....	5	维护和检查.....	9
规格.....	6	维修零部件一览表.....	10

电动工具通用安全警告

⚠ 警告！

阅读随电动工具提供的所有安全警告、说明、图示和规定。

不遵照以下所列说明会导致电击、着火和 / 或严重伤害。

保存所有警告和说明书以备查阅。

警告中的术语“电动工具”是指市电驱动（有线）电动工具或电池驱动（无线）电动工具。

1) 工作场地的安全

- a) 保持工作场地清洁和明亮。
杂乱和黑暗的场地会引发事故。
- b) 不要在易爆环境，如有易燃液体、气体或粉尘的环境下操作电动工具。
电动工具产生的火花会点燃粉尘或气体。
- c) 操作电动工具时，远离儿童和旁观者。
注意力不集中会使你失去对工具的控制。

2) 电气安全

- a) 电动工具插头必须与插座相配。绝不能以任何方式改装插头。需接地的电动工具不能使用任何转换插头。
未经改装的插头和相配的插座将降低电击风险。
- b) 避免人体接触接地表面，如管道、散热片和冰箱。
如果你身体接触接地表面会增加电击风险。
- c) 不得将电动工具暴露在雨中或潮湿环境中。
水进入电动工具将增加电击风险。
- d) 不得滥用软线。绝不能用软线搬运、拉动电动工具或拔出其插头。使软线远离热源、油、锐边或运动部件。
受损或缠绕的软线会增加电击风险。
- e) 当在户外使用电动工具时，使用适合户外使用的延长线。
适合户外使用的电线将降低电击风险。

- f) 如果无法避免在潮湿环境中操作电动工具，应使用带有剩余电流装置（RCD）保护的电源。
RCD 的使用可降低电击风险。

3) 人身安全

- a) 保持警觉，当操作电动工具时关注所从事的操作并保持清醒。当你感到疲倦，或在有药物、酒精或治疗反应时，不要操作电动工具。
在操作电动工具时瞬间的疏忽会导致严重人身伤害。
- b) 使用个人防护装置。始终佩戴护目镜。
防护装置，诸如适当条件下使用防尘面具、防滑安全鞋、安全帽、听力防护等装置能减少人身伤害。
- c) 防止意外起动。在连接电源和 / 或电池包、拿起或搬运工具前确保开关处于关断位置。
手指放在开关上搬运工具或开关处于接通时通电会导致危险。
- d) 在电动工具接通之前，拿掉所有调节钥匙或扳手。
遗留在电动工具旋转零件上的扳手或钥匙会导致人身伤害。
- e) 手不要过分伸展。时刻注意立足点和身体平衡。
这样能在意外情况下能更好地控制住电动工具。
- f) 着装适当。不要穿宽松衣服或佩戴饰品。让你的头发和衣服远离运动部件。
宽松衣服、佩饰或长发可能会卷入运动部件。
- g) 如果提供了与排屑、集尘设备连接用的装置，要确保其连接完好且使用得当。
使用集尘装置可降低尘屑引起的危险。
- h) 不要因为频繁使用工具而产生的熟悉感而掉以轻心，忽视工具的安全准则。
某个粗心的动作可能在瞬间导致严重的伤害。

4) 电动工具使用和注意事项

- a) 不要勉强使用电动工具，根据用途使用合适的电动工具。
选用合适的按照额定值设计的电动工具会使你工作更有效、更安全。
- b) 如果开关不能接通或关断电源，则不能使用该电动工具。
不能通过开关来控制的电动工具是危险的且必须进行修理。
- c) 在进行任何调节、更换附件或贮存电动工具之前，必须从电源上拔掉插头和 / 或卸下电池包（如可拆卸）。
这种防护性的安全措施降低了电动工具意外起动的风险。
- d) 将闲置不用的电动工具贮存在儿童所及范围之外，并且不允许不熟悉电动工具和不了解这些说明的人操作电动工具。
电动工具在未经培训的使用者手中是危险的。
- e) 维护电动工具及其附件。检查运动部件是否调整到位或卡住，检查零件破损情况和影响电动工具运行的其他状况。如有损坏，应在使用前修理好电动工具。
许多事故是由维护不良的电动工具引发的。

中文

- f) 保持切削刀具锋利和清洁。
维护良好地有锋利切削刃的刀具不易卡住而且容易控制。
 - g) 按照使用说明书，并考虑作业条件和要进行的作业来选择电动工具、附件和工具的刀头等。
将电动工具用于那些与其用途不符的操作可能会导致危险情况。
 - h) 保持手柄和握持表面干燥、清洁，不得沾有油脂。
在意外的情况下，湿滑的手柄不能保证握持的安全和对工具的控制。
- 5) 维修
- a) 由专业维修人员使用相同的备件维修电动工具。
这将保证所维修的电动工具的安全。

注意！

不可让儿童和体弱人士靠近工作场所。

应将不使用的工具存放在儿童和体弱人士接触不到的地方。

电钻安全警告

- 1) 当在钻削附件可能触及暗线或其自身导线的场合进行操作时，要通过绝缘握持面握持工具。钻削附件碰到带电导线会使工具外露的金属零件带电而使操作者受到电击。

使用电钻时应注意事项

- 1. 当在钻削附件可能触及暗线或其自身软线之处进行操作时，要通过绝缘握持面来握持工具。
钻削附件碰到带电导线会使工具外露的金属零件带电从而使操作者受到电击。
- 2. 安装钻头或螺丝刀头时，先把它完全插入钻头卡盘，然后用卡盘扳手拧紧钻头卡盘。
如果没有将钻头安装好，那将是很危险的，因为在作业中钻头会滑脱或松动。
- 3. 请勿戴容易被卷进的材料，如棉、毛、布、线等制成的手套。
- 4. 工作中或刚收工后，请勿碰钻头。因为工作中钻头会变得很热，可能会造成严重烧伤事故。
- 5. 将电钻放在地板上时，应先确认电钻是否已完全停止。
- 6. 使用时，请用双手握紧电钻。
- 7. 在往墙上、地板或天花板内钻孔时，要事先充分了解其中是否埋有电线或其它管道。
- 8. 在高空作业时，请注意下方。

符号

警告！

如下所示的符号用于本机。使用前请务必理解其含意。



为降低伤害风险，用户必须阅读使用说明书

规格

型式	FD10SA	FD10VA
电压	220 V ~	
输入功率	285 W	
空载转速	2300 /min	0-2300 /min
能力：钢铁	10 mm	
木材	18 mm	
重量（不含线缆）	1.1 kg	

用途

- 各种材料的钻孔
 - 金属 使用铁工钻头
 - 木材 使用木工钻头（但钻供木螺丝用的先导孔或小于 6.5 mm 的孔时，要使用铁工钻头）
- 木螺丝的拧紧（仅用于 FD10VA 型）
请使用螺丝刀头和飞利浦螺丝以便拧紧。

作业之前

- 电源
确认所使用的电源与产品铭牌上标示的规格相符。
- 电源开关
确认电源开关是否切断。若电源开关接通，则插头插入电源插座时电动工具将出其不意地立刻转动，从而招致严重事故。
- 延伸线缆
若作业场所移到离开电源的地点，应使用容量足够、铠装合适的延伸线缆，并且要尽可能地短些。
- 检查钻头卡盘是否拧紧
钻头卡盘在出厂时已被拧紧，但使用前请再检查一次，看其是否有松动。如有松动，请按顺时针方向拧紧钻头卡盘。

使用方法

- 开关的操作
拉扳机，推锁挡后，开关即保持接通状态，便可继续钻孔。要关掉开关时，请再拉一次扳机释放锁挡。

2. 速度调整

[FD10SA]

拉扳机开关即可获得最高速度。

[FD10VA]

(1) 速度可从零调整到最高速度，速度高低因扳机的范围大小而异。

(2) 最高速度可以旋转调整钮，可从零调整到 2300 /min。

(3) 按顺时针方向旋转调整钮，速度则变高；按逆时针方向旋转调整钮，速度则变低。（调整钮转一圈，钻头约转 3 转）（图 1）

(4) 无论调整钮已转到什么位置，都可用锁挡将开关锁定于该位置。请根据各工件的速度要求，选择适当位置。

3. 钻头转向的确认（图 2）

按下倒转开关手柄的 R 侧，钻头便按顺时针方向（从后面看去）旋转。按下倒转开关手柄的 L 侧，钻头便按逆时针方向旋转。

注意！

作业中请勿改变钻头转向。改变钻头转向之前应先关掉开关，否则会烧坏马达。

4. 作为钻机使用时

(1) 装上钻头

请用卡盘扳手拧紧钻头。在卡盘上有三个卡盘扳手可以插入的孔，固定钻头时，请平均用力拧紧三个孔，而不要只拧紧一个孔。用与上述相反的动作即可拆下钻头。（图 3）

(2) 钻孔方法

① 用于木材的钻孔

○ 先将钻头尖对准所要钻孔的地方并且保持钻头垂直于工件表面，然后打开开关。



图 1



图 2

旋紧（顺时针方向）

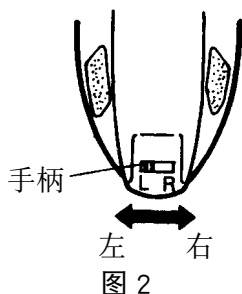

图 3

中文

- 当钻头穿透木材后，只要钻头的尖端从对面刚刚露出一个尖尖就尽快将钻头移出。然后翻转工作，从反面来完成钻孔以得到一个整齐的孔（图 4）。如果在钻孔木件下面还有另外一块要钻的木材，仿照上述方法也可钻一个整齐的孔（图 5）。
- 木工件的钻孔不需要加很大的压力，因为它类似于使用螺钉穿入。即使用过分大的力，钻孔速度也不会加快。
- ② 用于金属的钻孔
 - 用金工钻头对金属钻孔时，在钻孔位置先钻一个中心孔。这样钻孔较为安定，因为钻头尖端不会滑脱。
 - 如果用刷子或旧牙刷在钻头上涂上缝纫机油或肥皂水，钻头将更耐用。
 - 即使用力太大，钻孔速度也不会加快。相反地，钻头的边缘会受到损坏，以致降低工作效率并缩短钻头的使用寿命。

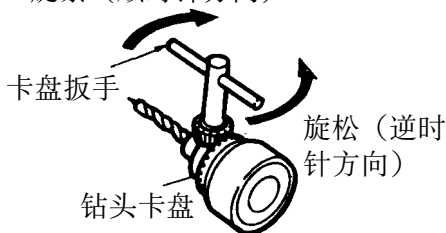
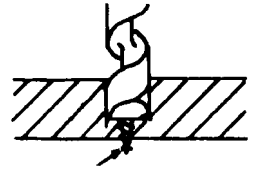

钻头尖端出现时，
将木材翻面

图 4

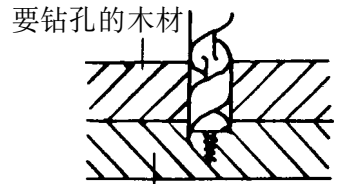

垫木

图 5

注意！

请勿让马达淋到水，以免引起马达故障与触电事故。

5. 使用传动木螺丝时（FD10VA）

(1) 螺丝刀头

- 旋入一字槽头木螺丝时，螺丝刀头容易脱落，因此请尽可能使用十字槽头木螺丝。
- 选用适合于木螺丝的十字槽头和一字槽头的螺丝刀头。

(2) 先导孔

如用略小于木螺丝直径的钻头开先导孔，木材便不会破裂，同时木螺丝也较容易旋入。

(3) 旋入作业

- 先将木螺丝轻轻放在先导孔内，然后把钻头对准槽，打开开关，旋入螺丝。

6. 收工后的注意事项

在旋转部件完全停止之前把钻头放在多尘处时，请确认机器不会吸入尘埃切屑。

维护和检查

注意！

维护和检查电钻之前，必须关闭电源开关并拔出电源插头。

1. 检查钻头和螺丝刀头

使用磨损的钻头会引起马达故障并降低钻孔效率，因此发现钻头磨损时应立即更换钻头或重新将其磨锋利。若使用尖端已磨损或断裂的钻头，将因滑脱而导致危险事故，所以应更换新的。

2. 检查安装螺钉

要经常检查安装螺钉是否紧固妥善。若发现螺钉松了，应立即重新扭紧，否则会导致严重的事故。

3. 更换电源线

必须更换电源线时，应由HiKOKI公司授权的维修中心来更换，以避免安全危险。

本电动工具的电源线损坏时必须更换成由维修组织特别准备的电源线。

4. 维修

电钻发生故障时，应与授权的服务中心商洽。

5. 维修零部件一览表

注意！

HiKOKI牌电动工具的维修、改造和检查须由经HiKOKI公司授权的维修中心进行。

当要求维修或其他保养服务时，若将此零部件一览表与电动工具一起呈交给经HiKOKI公司授权的维修中心，将有助于维修或保养工作。

在操作和维修电动工具时，必须遵守贵国制定的安全的有关规则 and 标准。

维修零部件一览表

FD10SA

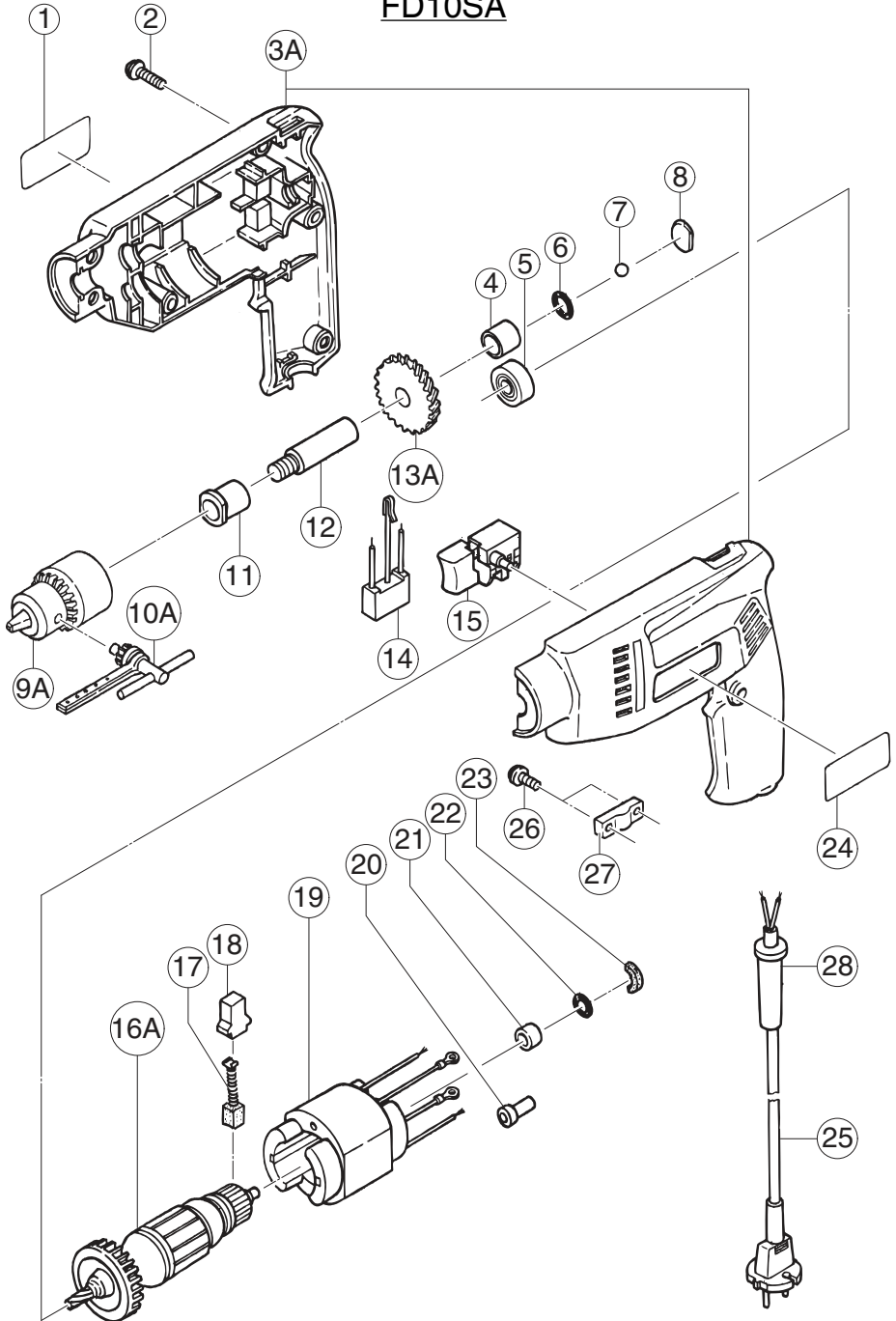

项目号	代码号	使用数	备注
1		1	
2	994806	7	D4x20
3A	994731	1	
4	954789	1	
5	608VVM	1	608VVC2PS2L
6	876031	1	S-16
7	959154	1	D5.556
8	954166	1	
9A	950292	1	10TLRA "10A"
10A	980057	1	10TL2
11	987072	1	
12	994720	1	
13A	994721	1	
14	987047	1	
15	994734	1	
16A	360038E	1	220V
17	999041	2	
18	930483	2	
19	340071E	1	220V
20	959141	1	
21	987106	1	
22	987105	1	S-10
23	994722	1	
24		1	
25	500409Z	1	
26	994810	2	D4x16
27	960266	1	
28	930487	1	D8.2

FD10VA

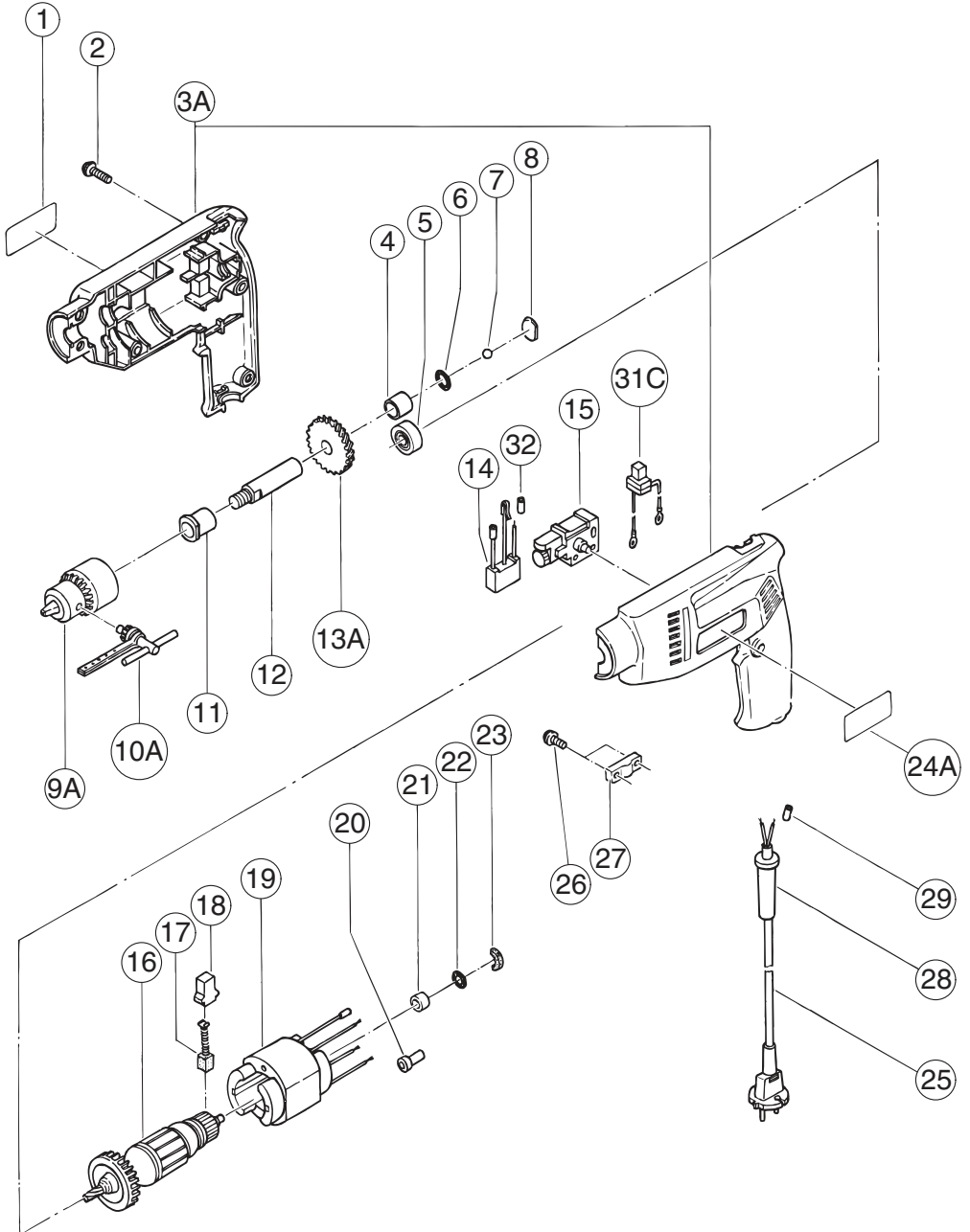

项目号	代码号	使用数	备注
1		1	
2	994806	7	D4x20
3A	994808	1	
4	954789	1	
5	608VVM	1	608VVC2PS2L
6	876031	1	S-16
7	959154	1	D5.556
8	954166	1	
9A	950292	1	10TLRA "10A"
10A	980057	1	10TL2
11	987072	1	
12	994807	1	
13A	994721	1	
14	987078	1	
15	987095	1	220V-240V
16	360044E	1	220V
17	999041	2	
18	930483	1	
19	340073E	1	220V
20	959141	1	
21	987106	1	
22	987105	1	S-10
23	994722	1	
24A		1	
25	500409Z	1	
26	994810	2	D4x16
27	960266	1	
28	930487	1	D8.2
29	981373	2	
31C	317126	1	
32	981373	1	

CONTENTS

GENERAL POWER TOOL SAFETY WARNINGS	14
DRILL SAFETY WARNINGS	16
PRECAUTIONS ON USING DRILL	17
SYMBOL.....	17
SPECIFICATIONS	18
APPLICATION	18
PRIOR TO OPERATION.....	18
HOW TO USE.....	19
MAINTENANCE AND INSPECTION	21
SERVICE PARTS LIST	22

GENERAL POWER TOOL SAFETY WARNINGS

WARNING

Read all safety warnings, instructions, illustrations and specifications provided with this power tool.

Failure to follow all instructions listed below may result in electric shock, fire and/or serious injury.

Save all warnings and instructions for future reference.

The term “power tool” in the warnings refers to your mains-operated (corded) power tool or battery-operated (cordless) power tool.

1) Work area safety

- a) **Keep work area clean and well lit.**
Cluttered or dark areas invite accidents.
- b) **Do not operate power tools in explosive atmospheres, such as in the presence of flammable liquids, gases or dust.**
Power tools create sparks which may ignite the dust or fumes.
- c) **Keep children and bystanders away while operating a power tool.**
Distractions can cause you to lose control.

2) Electrical safety

- a) **Power tool plugs must match the outlet. Never modify the plug in any way. Do not use any adapter plugs with earthed (grounded) power tools.**
Unmodified plugs and matching outlets will reduce risk of electric shock.
- b) **Avoid body contact with earthed or grounded surfaces, such as pipes, radiators, ranges and refrigerators.**
There is an increased risk of electric shock if your body is earthed or grounded.
- c) **Do not expose power tools to rain or wet conditions.**
Water entering a power tool will increase the risk of electric shock.

- d) **Do not abuse the cord. Never use the cord for carrying, pulling or unplugging the power tool.**
Keep cord away from heat, oil, sharp edges or moving parts.
Damaged or entangled cords increase the risk of electric shock.
- e) **When operating a power tool outdoors, use an extension cord suitable for outdoor use.**
Use of a cord suitable for outdoor use reduces the risk of electric shock.
- f) **If operating a power tool in a damp location is unavoidable, use a residual current device (RCD) protected supply.**
Use of an RCD reduces the risk of electric shock.

3) Personal safety

- a) **Stay alert, watch what you are doing and use common sense when operating a power tool.**
Do not use a power tool while you are tired or under the influence of drugs, alcohol or medication.
A moment of inattention while operating power tools may result in serious personal injury.
- b) **Use personal protective equipment. Always wear eye protection.**
Protective equipment such as a dust mask, non-skid safety shoes, hard hat or hearing protection used for appropriate conditions will reduce personal injuries.
- c) **Prevent unintentional starting. Ensure the switch is in the off-position before connecting to power source and/or battery pack, picking up or carrying the tool.**
Carrying power tools with your finger on the switch or energising power tools that have the switch on invites accidents.
- d) **Remove any adjusting key or wrench before turning the power tool on.**
A wrench or a key left attached to a rotating part of the power tool may result in personal injury.
- e) **Do not overreach. Keep proper footing and balance at all times.**
This enables better control of the power tool in unexpected situations.
- f) **Dress properly. Do not wear loose clothing or jewellery. Keep your hair and clothing away from moving parts.**
Loose clothes, jewellery or long hair can be caught in moving parts.
- g) **If devices are provided for the connection of dust extraction and collection facilities, ensure these are connected and properly used.**
Use of dust collection can reduce dust-related hazards.
- h) **Do not let familiarity gained from frequent use of tools allow you to become complacent and ignore tool safety principles.**
A careless action can cause severe injury within a fraction of a second.

4) Power tool use and care

- a) **Do not force the power tool. Use the correct power tool for your application.**
The correct power tool will do the job better and safer at the rate for which it was designed.

English

- b) **Do not use the power tool if the switch does not turn it on and off.**
Any power tool that cannot be controlled with the switch is dangerous and must be repaired.
 - c) **Disconnect the plug from the power source and/or remove the battery pack, if detachable, from the power tool before making any adjustments, changing accessories, or storing power tools.**
Such preventive safety measures reduce the risk of starting the power tool accidentally.
 - d) **Store idle power tools out of the reach of children and do not allow persons unfamiliar with the power tool or these instructions to operate the power tool.**
Power tools are dangerous in the hands of untrained users.
 - e) **Maintain power tools and accessories. Check for misalignment or binding of moving parts, breakage of parts and any other condition that may affect the power tool's operation. If damaged, have the power tool repaired before use.**
Many accidents are caused by poorly maintained power tools.
 - f) **Keep cutting tools sharp and clean.**
Properly maintained cutting tools with sharp cutting edges are less likely to bind and are easier to control.
 - g) **Use the power tool, accessories and tool bits etc. in accordance with these instructions, taking into account the working conditions and the work to be performed.**
Use of the power tool for operations different from those intended could result in a hazardous situation.
 - h) **Keep handles and grasping surfaces dry, clean and free from oil and grease.**
Slippery handles and grasping surfaces do not allow for safe handling and control of the tool in unexpected situations.
- 5) **Service**
- a) **Have your power tool serviced by a qualified repair person using only identical replacement parts.**
This will ensure that the safety of the power tool is maintained.

CAUTION

Keep children and infirm persons away.

When not in use, tools should be stored out of reach of children and infirm persons.

DRILL SAFETY WARNINGS

- 1) **Hold power tool by insulated gripping surfaces, when performing an operation where the cutting accessory may contact hidden wiring or its own cord. Cutting accessory contacting a "live" wire may make exposed metal parts of the power tool "live" and could give the operator an electric shock.**

PRECAUTIONS ON USING DRILL

1. Hold power tool by insulated gripping surfaces, when performing an operation where the cutting accessory may contact hidden wiring or its own cord. Cutting accessory contacting a “live” wire may make exposed metal parts of the power tool “live” and could give the operator an electric shock.
2. When mounting the drill bit or driver bit, insert it fully into the drill chuck and completely tighten the drill chuck with the chuck wrench.
If mounting is not done properly, it is very dangerous as the drill bit may slip or loosen during operation.
3. Do not wear gloves made of stuff liable to roll up such as cotton, wool, cloth or string, etc.
4. Do not touch the bit during or immediately after operation. The bit becomes very hot during operation and could cause serious burns.
5. When placing the drill on the floor, make sure that the drill has stopped completely.
6. Hold the drill firmly with both hands when using.
7. Before drilling into a wall, floor or ceiling, thoroughly confirm that no items such as electric cables or conduits are buried inside.
8. When working in high position, take care of downward direction.

SYMBOL

WARNING

The following show symbols used for the machine. Be sure that you understand their meaning before use.



To reduce the risk of injury, user must read instruction manual.

SPECIFICATIONS

Model	FD10SA	FD10VA
Voltage	220V ~	
Power Input	285 W	
No-load speed	2300 /min	0 - 2300 /min
Capacity: steel	10 mm	
wood	18 mm	
Weight (without cord)	1.1 kg	

APPLICATION

1. Drilling various materials
 - Drilling metal
Use an iron-working drill bit
 - Drilling wood
Use a wood-working drill bit (However, an iron-working drill bit to make pilot holes for wood screws or holes smaller than 6.5 mm.)
2. Tightening the wood screw (Only FD10VA model)
Use the driver bit. Use a Phillips screw for easy tightening.

PRIOR TO OPERATION

1. Power source
Ensure that the power source to be utilized conforms to the power requirements specified on the product nameplate.
2. Power switch
Ensure that the power switch is in the OFF position. If the plug is connected to a receptacle while the power switch is in the ON position, the power tool will start operating immediately, which could cause a serious accident.
3. Extension cord
When the work area is removed from the power source, use an extension cord of sufficient thickness and rated capacity. The extension cord should be kept as short as practicable.

4. Check the tightening of the drill chuck
The drill chuck has been tightened at the factory, but check again that it is in order before use. Turn the drill chuck clockwise to tighten.

HOW TO USE

1. Operation of switch
Pulling the trigger of switch and push the stopper, it keeps, the switched-on condition and it is convenient for the continuous running. When switched off, the stopper can be disconnected by means of pulling the trigger again.

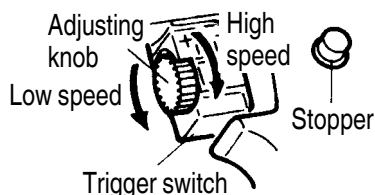

Fig. 1

2. Adjustment of speed

[FD10SA]

The maximum speed can be obtained by pulling the trigger switch.

[FD10VA]

- (1) The speed is adjustable from zero to maximum speed according to the extent the trigger switch is pulled.
 - (2) The maximum speed is adjustable from zero to 2300 /min with the rotation of adjusting knob.
 - (3) Turn the adjusting knob clockwise for higher speed and anticlockwise for lower speed. (Approximately three rotations consist one full rotation of the adjustment knob.) (Fig. 1)
 - (4) The switch can be locked with the stopper at any required position irrespective as to how far the adjusting knob has been rotated. Select a proper position according to the required speed for each work.
3. Confirm the direction of bit rotation (Fig. 2)
The bit rotates clockwise (viewed from the rear side) by pushing the R-side of the reversing switch lever. The L-side of the lever is pushed to turn the bit counterclockwise.

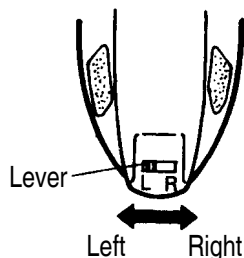

Fig. 2

CAUTION

Never change the direction of bit rotation while operating. Turn the power switch OFF before changing the direction of bit rotation; otherwise, burning of the motor will result.

4. For use as a drill
 - (1) Mounting drill bit
Tighten drill bit with the chuck wrench. There are three holes in which the chuck wrench should be inserted. Tighten them equally in turn at three holes, without tightening them only at one hole. The drill bit can be removed in the opposite method as mentioned above. (Fig 3)

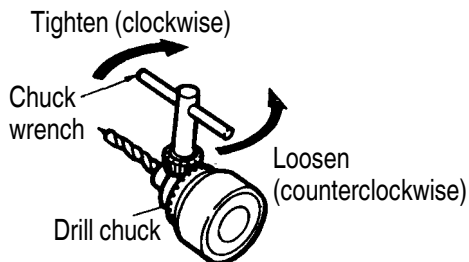

Fig 3

English

(2) How to drill

① To use for drilling lumber

- Apply the point of the drill bit to the desired drilling position, hold the drill perpendicular to the workpiece surface and turn on the switch.
- When drilling a through hole in lumber, remove the drill from the material as soon as the tip of the drill bit protrudes from the opposite surface. Then, turn the workpiece over and complete the drilling from the opposite side to obtain a clean hole. (Fig. 4)

If extra lumber is applied under the lumber you want to drill and it is drilled together, a fine hole will also be made. (Fig. 5)

- A wood-working drill need not be pressed strongly since it penetrates using the screw at the point. Even if excessive force is used, a hole will not be made quickly.
- ② To use for drilling metal
- In case you drill metal with an iron-working drill, apply in advance a center punch in the drilling position. You can drill metal stably since the point of the drill does not slip.
- If you apply sewing machine oil or soapy water to the drill with a brush or an old tooth brush, the drill will last long.
- Even if more-than-necessary force is used, a hole will not be made quickly. On the contrary, the edge of the drill will be damaged. This will decrease operational efficiency and shorten the life of this too.

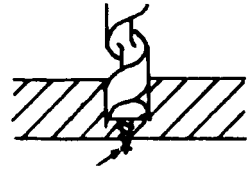

When the point appears, turn lumber over

Fig. 4

Lumber to be drilled

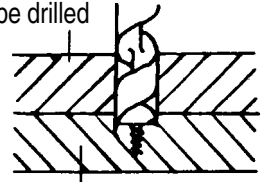

Extra lumber

Fig. 5

CAUTION

Do not expose the motor to water as it may cause motor malfunction and electric shock.

5. To use the driving wood screws (FD10VA)

(1) Driver bit

- For driving a minus wood screw, the driver bit detaches easily. So use wood screws with a plus groove as often as possible.
- Select a driver bit matching the plus groove and the minus groove of the wood screw.

(2) Pilot hole

If a pilot hole is made with a drill a little thinner than the diameter of the wood screw, the lumber will not be split and the wood screw will be driven with ease.

(3) Driving operation

- Put the wood screw lightly in the pilot hole, apply the bit to the groove, turn on the switch and drive the screw.

6. Caution to be taken immediately after operation

When placing the drill in dusty places before the rotating parts has stopped completely, make sure the machine does not suck in dust and swarf.

MAINTENANCE AND INSPECTION

CAUTION

Be sure to switch power OFF and disconnect the plug from the receptacle during maintenance and inspection.

1. Inspecting the drill bit and driver bit
Since use of an abraded drill bit will cause motor malfunctioning and degraded efficiency, replace the drill bit with a new one or resharpening without delay when abrasion is noted. If you use a driver bit of which point is worn or broken, it will be dangerous since it slips. So replace it with a new one.
2. Inspecting the mounting screws
Regularly inspect all mounting screws and ensure that they are properly tightened. Should any of the screws be loosened, retighten them immediately, Failure to do so could result in serious hazard.
3. Replacing supply cord
If the replacement of the supply cord is necessary, this has to be done by HiKOKI Authorized Service Center in order to avoid a safety hazard.
If the supply cord of this power tool is damaged, it must be replaced by a specially prepared cord available through the service organization.
4. Servicing
Consult an authorized Service Center in the event of power tool failure.
5. Service parts list

CAUTION

Repair, modification and inspection of HiKOKI Power Tools must be carried out by a HiKOKI Authorized Service Center.

This Parts List will be helpful if presented with the tool to the HiKOKI Authorized Service Center when requesting repair or other maintenance.

In the operation and maintenance of power tools, the safety regulations and standards prescribed in each country must be observed.

SERVICE PARTS LIST

FD10SA

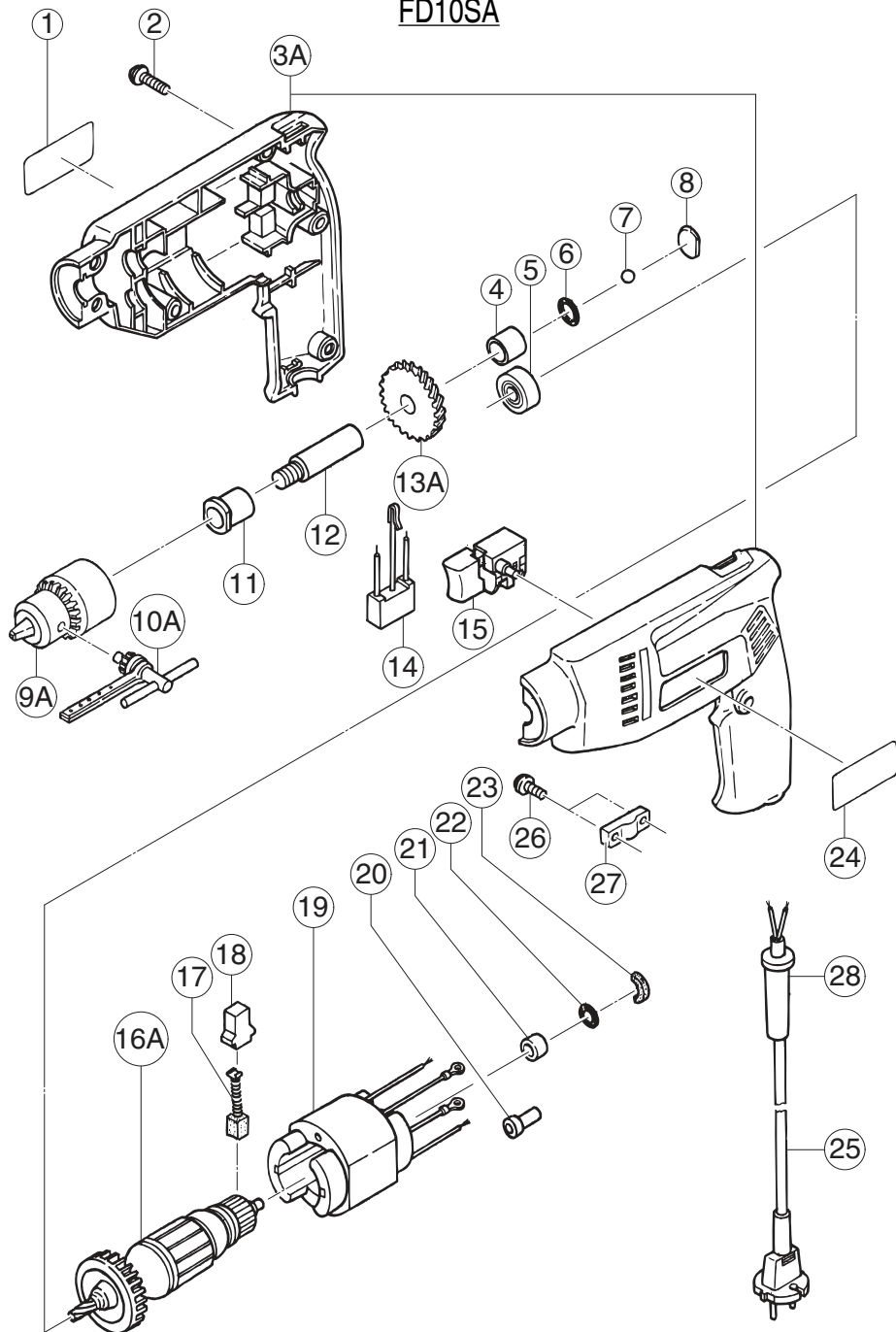

Item No.	Code No.	No. Used	Remarks
1		1	
2	994806	7	D4x20
3A	994731	1	
4	954789	1	
5	608VVM	1	608VVC2PS2L
6	876031	1	S-16
7	959154	1	D5.556
8	954166	1	
9A	950292	1	10TLRA "10A"
10A	980057	1	10TL2
11	987072	1	
12	994720	1	
13A	994721	1	
14	987047	1	
15	994734	1	
16A	360038E	1	220V
17	999041	2	
18	930483	2	
19	340071E	1	220V
20	959141	1	
21	987106	1	
22	987105	1	S-10
23	994722	1	
24		1	
25	500409Z	1	
26	994810	2	D4x16
27	960266	1	
28	930487	1	D8.2

FD10VA

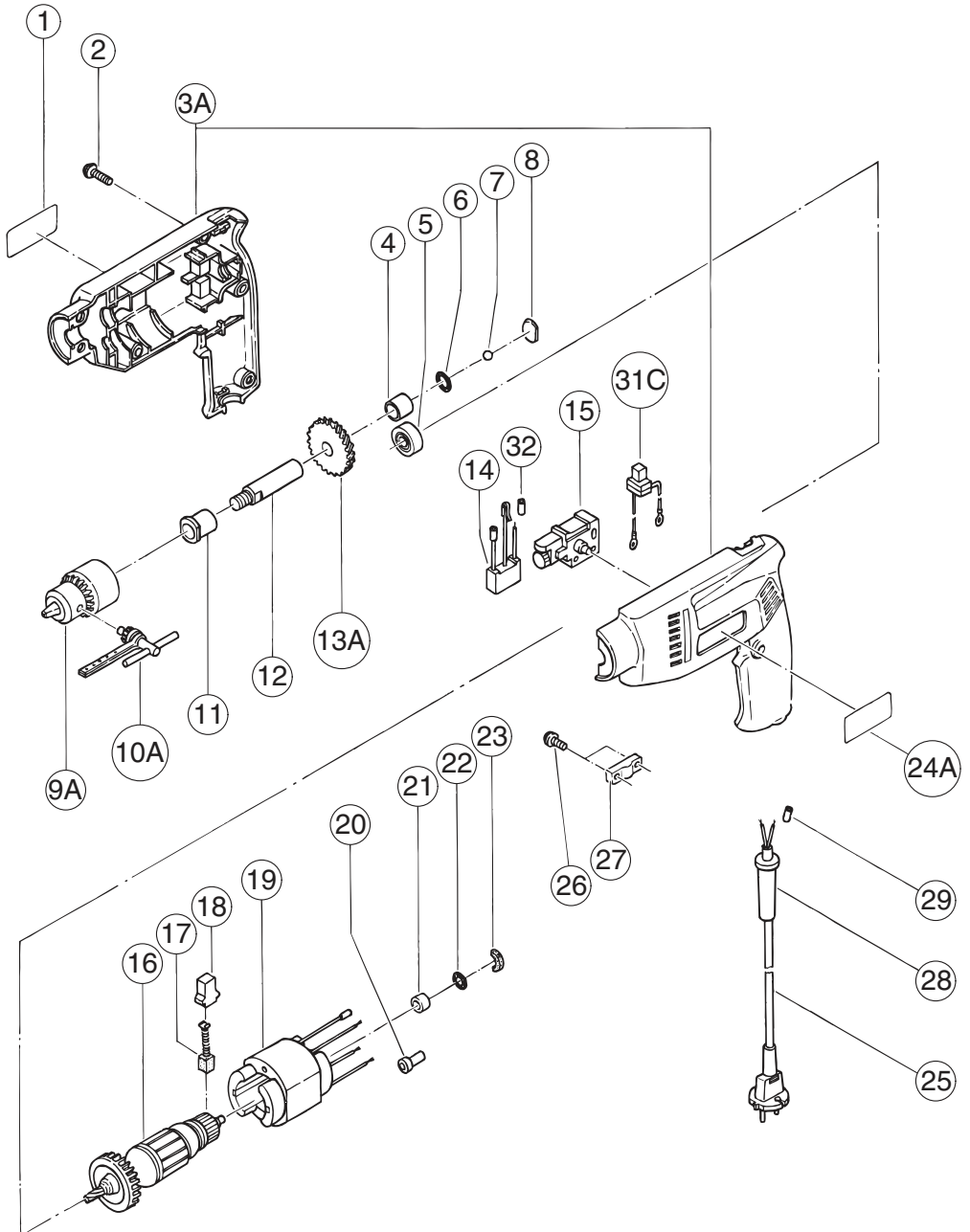

Item No.	Code No.	No. Used	Remarks
1		1	
2	994806	7	D4x20
3A	994808	1	
4	954789	1	
5	608VVM	1	608VVC2PS2L
6	876031	1	S-16
7	959154	1	D5.556
8	954166	1	
9A	950292	1	10TLRA "10A"
10A	980057	1	10TL2
11	987072	1	
12	994807	1	
13A	994721	1	
14	987078	1	
15	987095	1	220V-240V
16	360044E	1	220V
17	999041	2	
18	930483	1	
19	340073E	1	220V
20	959141	1	
21	987106	1	
22	987105	1	S-10
23	994722	1	
24A		1	
25	500409Z	1	
26	994810	2	D4x16
27	960266	1	
28	930487	1	D8.2
29	981373	2	
31C	317126	1	
32	981373	1	

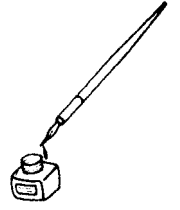

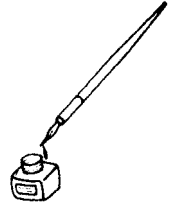

服务中心
高壹工机商业(上海)有限公司
上海市闵行区浦江工业园区三鲁路3585号7幢3楼

制造商
福建高壹工机有限公司
福建省福州市福兴投资区湖塘路

Koki Holdings Co., Ltd.

109
编号: C99267221 F
发行日期: 2021年 9月
中国印刷