

HiKOKI

盘式轨道砂光机
Random Orbit Sander

SV 13YA • SV 13YB

中文
English

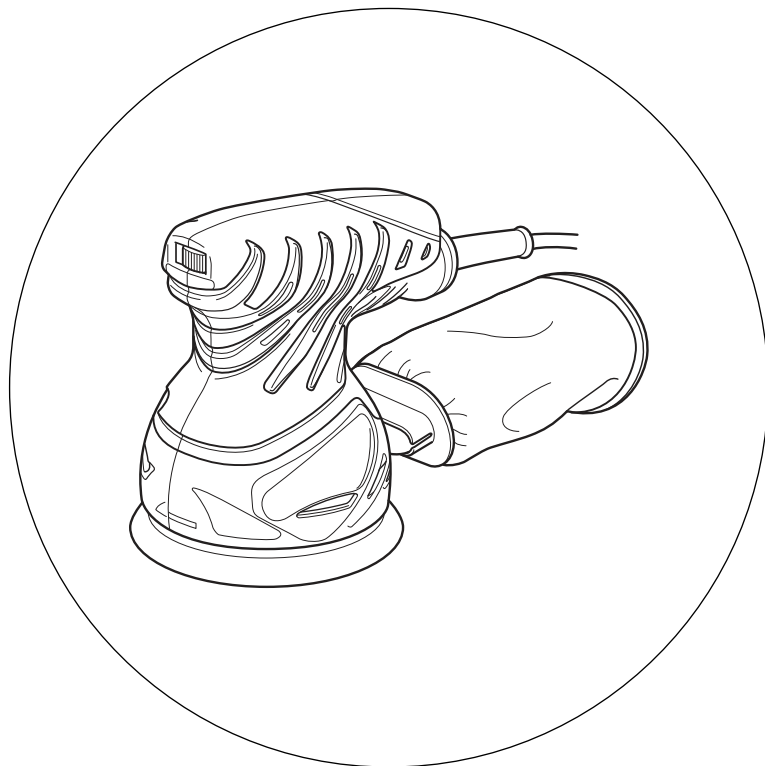

保留备用
Keep for future reference



使用说明书
Handling instructions



目次

电动工具通用安全警告.....	2	作业之前.....	5
符号.....	4	使用方法.....	7
规格.....	4	安装选购附件.....	8
标准附件.....	5	维护和检查.....	8
选购附件（分开销售）.....	5	附加信息.....	9
用途.....	5	维修零部件一览表.....	10

电动工具通用安全警告

⚠ 警告！

阅读随电动工具提供的所有安全警告、说明、图示和规定。
不遵照以下所列说明会导致电击、着火和 / 或严重伤害。

保存所有警告和说明书以备查阅。

在所有下列的警告中术语“电动工具”指市电驱动(有线)电动工具或电池驱动(无线)电动工具。

a) 工作场地的安全

- 1) 保持工作场地清洁和明亮。
杂乱和黑暗的场地会引发事故。
- 2) 不要在易爆环境，如有易燃液体、气体或粉尘的环境下操作电动工具。
电动工具产生的火花会点燃粉尘或气体。
- 3) 操作电动工具时，远离儿童和旁观者。
注意力不集中会使你失去对工具的控制。

b) 电气安全

- 1) 电动工具插头必须与插座相配。绝不能以任何方式改装插头。需接地的电动工具不能使用任何转换插头。
未经改装的插头和相配的插座将降低电击风险。
- 2) 避免人体接触接地表面，如管道、散热片和冰箱。
如果你身体接触接地表面会增加电击风险。
- 3) 不得将电动工具暴露在雨中或潮湿环境中。
水进入电动工具将增加电击风险。
- 4) 不得滥用软电线。绝不能用软电线搬运、拉动电动工具或拔出其插头。
使软电线远离热源、油、锐边或运动部件。
受损或缠绕的软线会增加电击风险。
- 5) 当在户外使用电动工具时，使用适合户外使用的延长线。
适合户外使用的电线将降低电击风险。

- 6) 如果无法避免在潮湿环境中操作电动工具，应使用带有剩余电流装置（RCD）保护的电源。

RCD的使用可降低电击风险。

c) 人身安全

- 1) 保持警觉，当操作电动工具时关注所从事的操作并保持清醒。当你感到疲倦，或在有药物、酒精或治疗反应时，不要操作电动工具。
在操作电动工具时瞬间的疏忽会导致严重人身伤害。
- 2) 使用个人防护装置。始终佩戴护目镜。
防护装置，诸如适当条件下使用防尘面具、防滑安全鞋、安全帽、听力防护等装置能减少人身伤害。
- 3) 防止意外起动。在连接电源和 / 或电池包、拿起或搬运工具前确保开关处于关断位置。
手指放在开关上搬运工具或开关处于接通时通电会导致危险。
- 4) 在电动工具接通之前，拿掉所有调节钥匙或扳手。
遗留在电动工具旋转零件上的扳手或钥匙会导致人身伤害。
- 5) 手不要过分伸展。时刻注意立足点和身体平衡。
这样能在意外情况下能更好地控制住电动工具。
- 6) 着装适当。不要穿宽松衣服或佩戴饰品。让你的头发和衣服远离运动部件。
宽松衣服、佩饰或长发可能会卷入运动部件。
- 7) 如果提供了与排屑、集尘设备连接用的装置，要确保其连接完好且使用得当。
使用集尘装置可降低尘屑引起的危险。
- 8) 不要因为频繁使用工具而产生的熟悉感而掉以轻心，忽视工具的安全准则。
某个粗心的动作可能在瞬间导致严重的伤害。

d) 电动工具使用和注意事项

- 1) 不要勉强使用电动工具，根据用途使用合适的电动工具。
选用合适的按照额定值设计的电动工具会使你工作更有效、更安全。
- 2) 如果开关不能通过或关断电源，则不能使用该电动工具。
不能用开关来控制的电动工具是危险的且必须进行修理。
- 3) 在进行任何调节、更换附件或贮存电动工具之前，必须从电源上拔掉插头和 / 或卸下电池包（如可拆卸）。
这种防护性的安全措施降低了电动工具意外起动的风险。
- 4) 将闲置不用的电动工具贮存在儿童所及范围之外，并且不允许不熟悉电动工具和不了解这些说明的人操作电动工具。
电动工具在未经培训的使用者手中是危险的。
- 5) 维护电动工具及其附件。检查运动部件是否调整到位或卡住，检查零件破损情况和影响电动工具运行的其他状况。如有损坏，应在使用前修理好电动工具。
许多事故是由维护不良的电动工具引发的。

中文

- 6) 保持切削刀具锋利和清洁。
维护良好的有锋利切削刃的刀具不易卡住而且容易控制。
- 7) 按照使用说明书，并考虑作业条件和要进行的作业来选择电动工具、附件和工具的刀头等。
将电动工具用于那些与其用途不符的操作可能会导致危险情况。
- 8) 不要因为频繁使用工具而产生的熟悉感而掉以轻心，忽视工具的安全准则。
某个粗心的动作可能在瞬间导致严重的伤害。

e) 维修

- 1) 由专业维修人员使用相同的备件维修电动工具。
这将保证所维修的电动工具的安全。

注意！

不可让儿童和体弱人士靠近工作场所。

应将不使用的工具存放在儿童和体弱人士接触不到的地方。

符号

警告！

如下所示的符号用于本机。使用前请务必理解其含意。





为降低伤害风险，用户必须阅读使用说明书

规格

型式	SV13YA	SV13YB
电压	220 V ~	
输入功率	230 W	
空载转速	7000 – 12000 /min	12000 /min
砂纸垫板尺寸（外径）	125 mm	
砂纸尺寸（外径）	125 mm	
重量（不含线缆）	1.4 kg	

标准附件

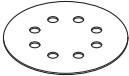
除了主机（1 台）外，产品包中还包括表中所列的附件。

砂纸		1
粉尘袋		1

选购附件（分开销售）

1. 砂纸
颗粒度：AA40、AA60、AA80、AA120、AA180、AA240、AA320、AA400
2. 聚酯革

用途

- 木工件和金属表面的粗略打磨或抛光。
- 木工件和金属表面在油漆前的初步打磨。
- 除漆。
- 除锈。

作业之前

1. 电源
确认所使用的电源与产品铭牌上标示的规格相符。
2. 电源开关
确认电源开关是否切断。若电源开关接通，则插头插入电源插座时电动工具将出其不意地立刻转动，从而招致严重事故。
3. 延伸线缆
若作业场所移到离开电源的地点，应使用足够长及牢固的延伸线缆，并且但实际作业时，尽量不要将延伸线缆拉得太长。



图 1

4. 安装砂纸
由于砂纸的安装属于钩环型安装，因此只需将砂纸按压在垫板上即可。安装砂纸时，如图 1 所示，将其沿两个孔之间的轴线轻轻折叠，以便使砂纸与垫板上的孔相匹配。

中文

然后，沿着折叠线的孔使砂纸与垫板相匹配。最后，将整块砂纸均匀地按压到垫板上。

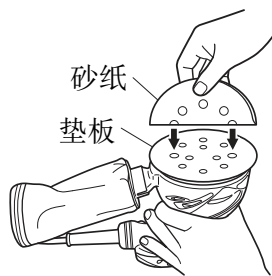
5. 安装和拆卸粉尘袋

(1) 安装粉尘袋

如图 2 所示，抓住集尘门并将其沿箭头 A 的方向推，将其装到粉尘出口。

(2) 拆卸粉尘袋

如图 2 所示，抓住集尘门并将其沿箭头 B 的方向拉，将其从粉尘出口拆下。



图 2

注意！

在打磨操作之前要先确定打磨的表面材料。

如果要进行打磨操作的表面会产生有害或有毒的尘土，例如由铅着色的表面，就要确保装尘土的袋子或适当的尘土抽取系统和尘土排放口紧密地连接在一起。

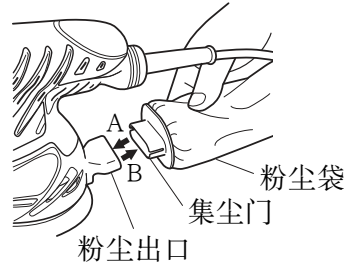
如果有必要，另外还要带上防尘面具。

不要吸入或接触在打磨过程中产生的有害或有毒的尘土，这类尘土会危及到操作者自身及旁观者的身体健康。

6. 调整速度（仅 SV13YA）

SV13YA 的电控电路可实现无级速控。要调整速度，如图 3 所示转动拨盘。拨盘设为“1”时，磨光机以最小速度（7000 /min）运行；拨盘设为“6”时，磨光机以最大速度（12000 /min）运行。请根据要切削的材料和工作效率调整速度。



图 3

通过调整拨盘，使速度符合材料和工件类型的要求。

材料	颗粒度		拨盘刻度
	粗略打磨	精细打磨	
油漆件： 打磨 修复 (划伤、锈点) 去除漆层	180	400	3-6
	120	240	2-4
	40	80	2-4
木工件： 软木 硬木 胶合板	60-80	240	3-6
	60	180	3-5
	240	320	2-4
金属： 铝 钢 不锈钢	80	240	2-4
	60	240	3-6
	120	240	3-6

注：

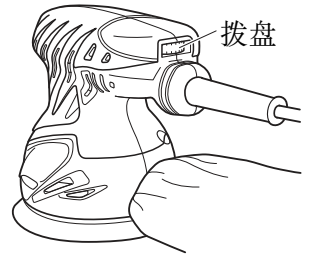
请以此表中的数据为标准。

使用方法

注意！

打磨时切勿喷水或磨削液。否则会招致触电。

1. 启动和关闭砂光机

将手柄设定在 ON (I) 位置可接通电源，而将其设定在 OFF (0) 位置则可关闭电源。

注意！

切勿在砂光机接触打磨面时打开电源开关。这可保护材料免受损坏。关闭电源时同样如此。

2. 如何握持盘式轨道砂光机

如图 4 所示，在抓住机壳的同时，将砂光机轻轻抵住要打磨的表面，使砂纸均匀接触打磨面。打磨时切勿对砂光机用力过猛。否则会导致电动机过载，砂纸使用寿命降低，以及打磨或抛光效率低下。



图 4

中文

3. 如何移动盘式轨道砂光机

砂光机可以来回移动或沿一侧逐渐转圈移动(图 5 和图 6)。

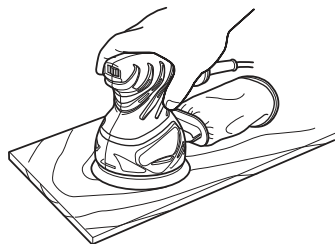
4. 安装新的砂纸之后

安装新砂纸之后, 由于其颗粒新且粗糙, 因此砂光机的移动可能会变得不稳定。这可通过在打磨或抛光时略微向前或向后倾斜砂光机予以避免。砂光机的移动在砂纸适当研磨之后将变得稳定。



图 5



图 6

安装选购附件

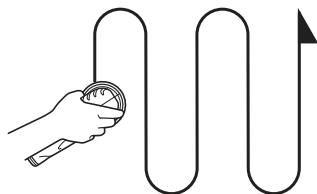
○ 安装聚酯革

聚酯革的安装与砂纸的安装一样, 属于钩环型安装, 因此只需将其按压到垫板上即可(图 7)。

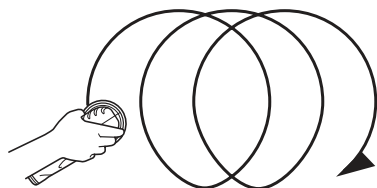

图 7

维护和检查

1. 倒空和清扫粉尘袋

粉尘袋里的粉尘过多时, 砂光机的集尘效果将会降低。所以, 当粉尘袋里的粉尘满了时, 请将粉尘袋倒空。

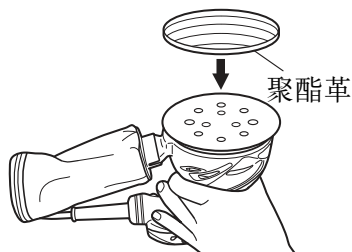
请先卸下粉尘袋, 然后拉开拉链, 倒掉粉尘。

2. 检查砂纸

如继续使用磨损了的砂纸, 会降低工作效率, 并可能磨损砂纸垫板, 所以砂纸一旦出现磨损就请及时更换。

3. 检查安装螺钉

要经常检查安装螺钉是否紧固妥善。若发现螺钉松了, 应立即重新扭紧, 否则会导致严重的事故。

4. 电动机的维护

电动机绕线是电动工具的“心脏部”。

应仔细检查有无损伤，是否被油液或水沾湿。

5. 维修

若电动工具出现故障，请向HiKOKI授权的维修中心垂询。

6. 维修零部件一览表

注意！

HiKOKI牌电动工具的维修、改造和检查须由经HiKOKI公司授权的维修中心进行。

当要求维修或其他保养服务时，若将此零部件一览表与电动工具一起呈交给经HiKOKI公司授权的维修中心，将有助于维修或保养工作。

在操作和维修电动工具时，必须遵守贵国制定的安全的有关规则和标准。

附加信息

生产月份和年份的数据见机器和包装的铭牌，以数字和字母编码的月份：1 - 9 是 1 - 9 月、0 是 10 月、N 是 11 月、D 是 12 月，生产年份按当年度最后一位数字编码。

维修零部件一览表

SV13YA

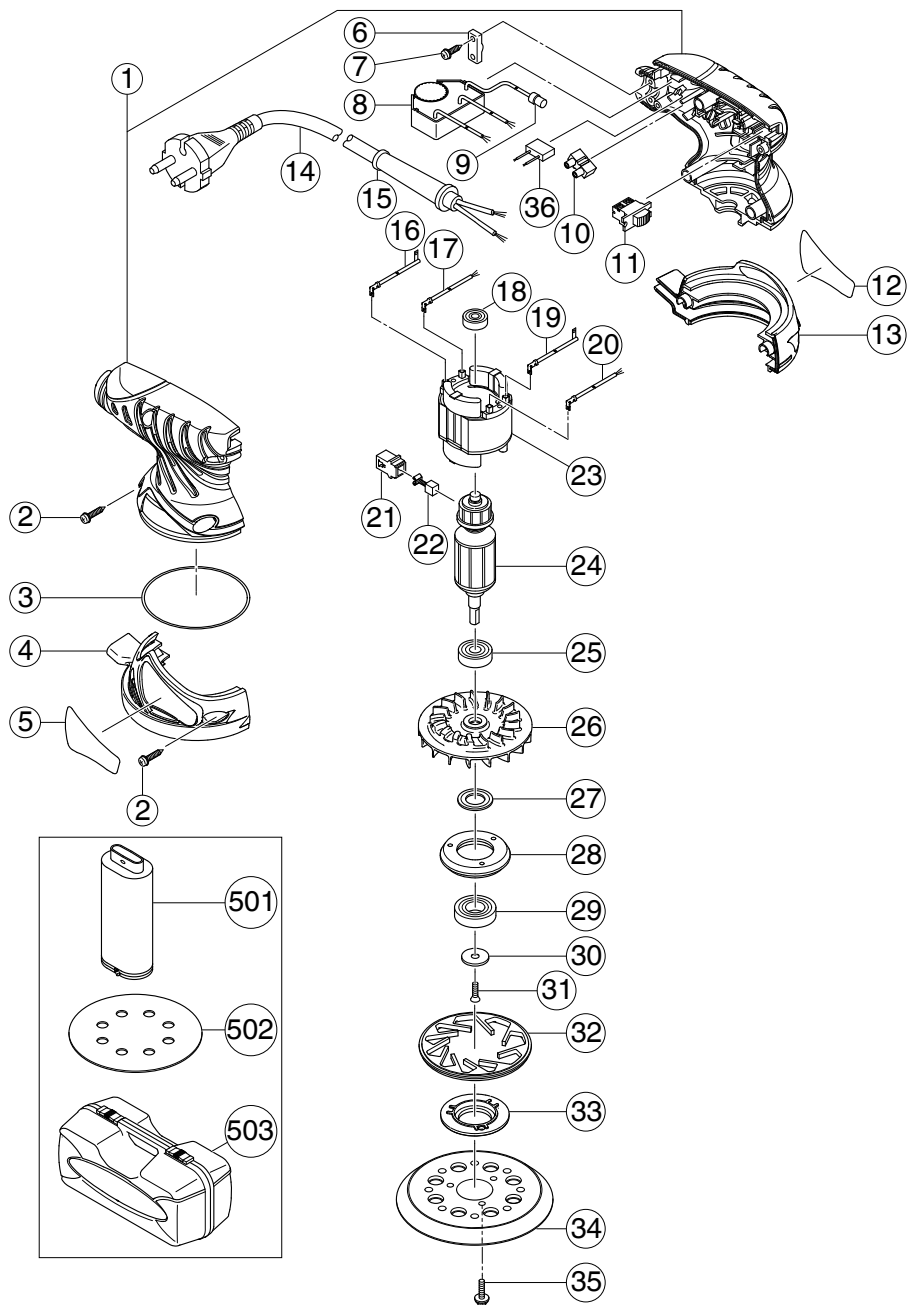

项目号	代码号	使用数	备注
1	324-249	1	
2	301-653	7	D4 × 20
3	993-195	1	
4	324-207	1	
5	_____	1	
6	937-631	1	
7	984-750	2	D4 × 16
8	324-248	1	220V
9	959-140	1	
10	938-307	1	
11	311-948	1	
12	_____	1	
13	324-206	1	
14	500-439Z	1	
15	953-327	1	D8.8
16	322-764	1	
17	322-761	1	
18	626-VVM	1	626VVC2PS2L
19	322-763	1	
20	322-762	1	
21	930-483	2	
22	999-041	2	
23	340-616E	1	220V-230V
24	360-696E	1	220V-230V
25	629-VVM	1	629VVC2PS2L
26	324-521	1	
27	324-208	1	
28	324-212	1	
29	600-2DW	1	6002DDWCMP2L
30	309-422	1	
31	993-244	1	M4 × 12
32	324-210	1	
33	324-211	1	
34	324-209	1	
35	307-109	3	M4 × 16
36	930-039	1	
501	310-339	1	
502	308-519	1	A-P120
503	324-613	1	

项目号	代码号	使用数	备注
1	324-214	1	
2	301-653	7	D4 × 20
3	993-195	1	
4	324-207	1	
5	_____	1	
6	984-750	2	D4 × 16
7	937-631	1	
8	930-039	1	
9	938-307	1	
10	311-948	1	
11	_____	1	
12	324-206	1	
13	500-468Z	1	
14	953-327	1	D8.8
15	322-764	1	
16	322-761	1	
17	626-VVM	1	626VVC2PS2L
18	322-763	1	
19	322-762	1	
20	930-483	2	
21	999-041	2	
22	340-618E	1	220V-230V
23	360-698E	1	220V-230V
24	629-VVM	1	629VVC2PS2L
25	324-521	1	
26	324-208	1	
27	324-212	1	
28	600-2DW	1	6002DDWCMP2L
29	309-422	1	
30	993-244	1	M4 × 12
31	324-210	1	
32	324-211	1	
33	324-209	1	
34	307-109	3	M4 × 16
501	310-339	1	
502	308-519	1	A-P120

CONTENTS

GENERAL POWER TOOL SAFETY WARNINGS	14
SYMBOL.....	16
SPECIFICATIONS.....	17
STANDARD ACCESSORIES	17
OPTIONAL ACCESSORIES (sold separately).....	17
APPLICATIONS.....	17
PRIOR TO OPERATION.....	17
PRACTICAL OPERATING PROCEDURES.....	19
MOUNTING THE OPTIONAL ACCESSORIES	20
MAINTENANCE AND INSPECTION	20
SERVICE PARTS LIST	22

GENERAL POWER TOOL SAFETY WARNINGS

WARNING

Read all safety warnings and all instructions.

Failure to follow the warnings and instructions may result in electric shock, fire and/or serious injury.

Save all warnings and instructions for future reference.

The term “power tool” in the warnings refers to your mains-operated (corded) power tool or battery-operated (cordless) power tool.

1) Work area safety

a) Keep work area clean and well lit.

Cluttered or dark areas invite accidents.

b) Do not operate power tools in explosive atmospheres, such as in the presence of flammable liquids, gases or dust.

Power tools create sparks which may ignite the dust or fumes.

c) Keep children and bystanders away while operating a power tool.

Distractions can cause you to lose control.

2) Electrical safety

a) Power tool plugs must match the outlet.

Never modify the plug in any way.

Do not use any adapter plugs with earthed (grounded) power tools.

Unmodified plugs and matching outlets will reduce risk of electric shock.

b) Avoid body contact with earthed or grounded surfaces, such as pipes, radiators, ranges and refrigerators.

There is an increased risk of electric shock if your body is earthed or grounded.

c) Do not expose power tools to rain or wet conditions.

Water entering a power tool will increase the risk of electric shock.

- d) **Do not abuse the cord. Never use the cord for carrying, pulling or unplugging the power tool.**
Keep cord away from heat, oil, sharp edges or moving parts.
Damaged or entangled cords increase the risk of electric shock.
- e) **When operating a power tool outdoors, use an extension cord suitable for outdoor use.**
Use of a cord suitable for outdoor use reduces the risk of electric shock.
- f) **If operating a power tool in a damp location is unavoidable, use a residual current device (RCD) protected supply.**
Use of an RCD reduces the risk of electric shock.

3) Personal safety

- a) **Stay alert, watch what you are doing and use common sense when operating a power tool.**
Do not use a power tool while you are tired or under the influence of drugs, alcohol or medication.
A moment of inattention while operating power tools may result in serious personal injury.
- b) **Use personal protective equipment. Always wear eye protection.**
Protective equipment such as dust mask, non-skid safety shoes, hard hat, or hearing protection used for appropriate conditions will reduce personal injuries.
- c) **Prevent unintentional starting. Ensure the switch is in the off position before connecting to power source and/or battery pack, picking up or carrying the tool.**
Carrying power tools with your finger on the switch or energising power tools that have the switch on invites accidents.
- d) **Remove any adjusting key or wrench before turning the power tool on.**
A wrench or a key left attached to a rotating part of the power tool may result in personal injury.
- e) **Do not overreach. Keep proper footing and balance at all times.**
This enables better control of the power tool in unexpected situations.
- f) **Dress properly. Do not wear loose clothing or jewellery. Keep your hair, clothing and gloves away from moving parts.**
Loose clothes, jewellery or long hair can be caught in moving parts.
- g) **If devices are provided for the connection of dust extraction and collection facilities, ensure these are connected and properly used.**
Use of dust collection can reduce dust-related hazards.

4) Power tool use and care

- a) **Do not force the power tool. Use the correct power tool for your application.**
The correct power tool will do the job better and safer at the rate for which it was designed.
- b) **Do not use the power tool if the switch does not turn it on and off.**
Any power tool that cannot be controlled with the switch is dangerous and must be repaired.

English

- c) **Disconnect the plug from the power source and/or the battery pack from the power tool before making any adjustments, changing accessories, or storing power tools.**

Such preventive safety measures reduce the risk of starting the power tool accidentally.

- d) **Store idle power tools out of the reach of children and do not allow persons unfamiliar with the power tool or these instructions to operate the power tool.**

Power tools are dangerous in the hands of untrained users.

- e) **Maintain power tools. Check for misalignment or binding of moving parts, breakage of parts and any other condition that may affect the power tool's operation.**

If damaged, have the power tool repaired before use.

Many accidents are caused by poorly maintained power tools.

- f) **Keep cutting tools sharp and clean.**

Properly maintained cutting tools with sharp cutting edges are less likely to bind and are easier to control.

- g) **Use the power tool, accessories and tool bits etc. in accordance with these instructions, taking into account the working conditions and the work to be performed.**

Use of the power tool for operations different from those intended could result in a hazardous situation.

5) Service

- a) **Have your power tool serviced by a qualified repair person using only identical replacement parts.**

This will ensure that the safety of the power tool is maintained.

CAUTION

Keep children and infirm persons away.

When not in use, tools should be stored out of reach of children and infirm persons.

SYMBOL

WARNING

The following show symbols used for the machine. Be sure that you understand their meaning before use.





To reduce the risk of injury, user must read instruction manual.

SPECIFICATIONS

Model	SV13YA	SV13YB
Voltage	220V ~	
Power Input	230 W	
No-load speed	7000 – 12000 /min	12000 /min
Sanding pad size (Outer diameter)	125 mm	
Sanding paper size (Outer diameter)	125 mm	
Weight (without cord)	1.4 Kg	

STANDARD ACCESSORIES

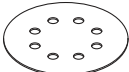
In addition to the main unit (1 unit), the package contains the accessories listed in the below.

Sanding paper		1
Dust bag		1

OPTIONAL ACCESSORIES (sold separately)

1. Sanding paper
Grain: AA40, AA60, AA80, AA120, AA180, AA240, AA320, AA400
2. Polyester buff

APPLICATIONS

- Roughing or finishing of woodwork and metal surfaces.
- Preliminary sanding of woodwork and metal surfaces before painting.
- Paint removal.
- Rust removal.

PRIOR TO OPERATION

1. Power source
Ensure that the power source to be utilized conforms to the power requirements specified on the product nameplate.
2. Power switch
Ensure that the power switch is in the OFF position. If the plug is connected to a receptacle while the power switch is in the ON position, the power tool will start operating immediately, which could cause a serious accident.

English

3. Extension cord

When the work area is removed from the power source, use an extension cord of sufficient thickness and rated capacity. The extension cord should be kept as short as practicable.

4. Installing the sanding paper

Since the attachment is a hook-and-loop type, the sanding paper can be installed easily by just pressing it onto the pad. When installing the sanding paper, in order to match it to the holes in the pad, gently fold it along the axis of two holes as shown in **Fig. 1**.

Next, use the holes along the fold as a guide to match the sanding paper and the pad. Finally, press the entire sanding paper uniformly onto the pad.

5. Attaching and Removing the Dust Bag

(1) Attaching the Dust Bag

As shown in **Fig. 2**, hold the dust gate and push it in the direction of Arrow A to attach it to the dust outlet.

(2) Removing the Dust Bag

As shown in **Fig. 2**, hold the dust gate and pull it in the direction of Arrow B to remove it from the dust outlet.

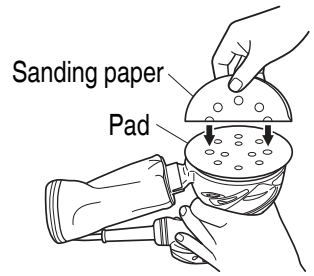

Fig. 1

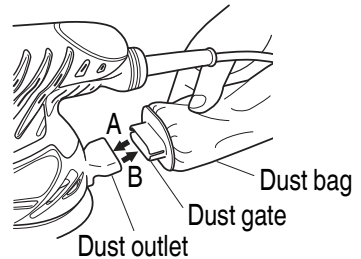

Fig. 2

CAUTION

Prior to the sanding operation, make sure the material of surface you are going to sand.

If the surface under sanding operation is expected to generate harmful / toxic dusts such as lead painted surface, make sure the dust bag or appropriate dust extraction system is connected with dust outlet tightly.

Wear the dust mask additionally, if available.

Do not inhale or touch the harmful / toxic dusts generated in sanding operation, the dust can endanger the health of yourself and bystanders.

6. Adjustment of speed (SV13YA only)

The SV13YA is equipped with the electric control circuit which enables non-step speed control. To adjust the speed, turn the dial shown in **Fig. 3**. When the dial is set to "1", the sander operates at the minimum speed (7000 min). When the dial set to "6", the sander operates at the maximum speed (12000 min). Adjust the speed according to the material to be cut and working efficiency.

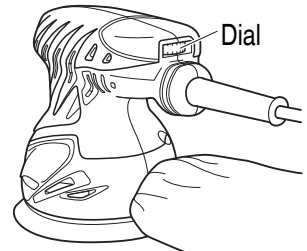

Fig. 3

By adjusting the dial, match the speed to the material and type of work.

Material	Grain		Dial scale
	Rough grinding	Fine grinding	
Paintwork: Sanding	180	400	3 – 6
Repairs (scratches, rust spots)	120	240	2 – 4
Stripping	40	80	2 – 4
Wood:			
Softwood	60 – 80	240	3 – 6
Hardwood	60	180	3 – 5
Veneers	240	320	2 – 4
Metals:			
Aluminium	80	240	2 – 4
Steel	60	240	3 – 6
Stainless steel	120	240	3 – 6

NOTE

Please use this table as a standard.

PRACTICAL OPERATING PROCEDURES

CAUTION

Never apply water or grinding fluid when sanding. This could result in electrical shock.

- Switching the sander ON and OFF
The power can be turned on by setting the lever to ON (I) and turned off by setting the lever to OFF (O).

CAUTION

Never turn the power switch ON when the sander is contacting the surface to be sanded. This is necessary to preclude damage to the material. The same applies when switching the power OFF.

- How to hold the random orbit sander
While gripping the housing, lightly press the sander against the surface to be sanded so that the sanding paper uniformly contacts the surface, as shown in **Fig. 4**. **DO NOT** apply excessive pressure to the sander while sanding. Excessive-pressure may cause overload of the motor, reduced service life of the sanding paper, and lowered sanding or polishing efficiency.

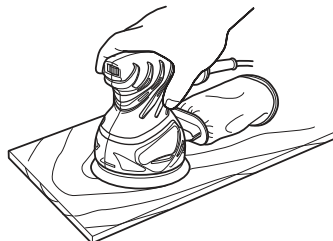
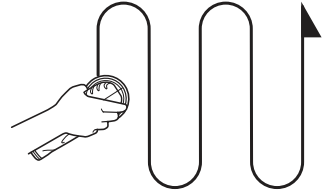

Fig. 4

English

- How to move the random orbit sander
Move the sander by either moving it up and down or by moving it in circles while gradually progressing in a sideways direction (**Figs. 5 and 6**).
- After installing new sanding paper
Movement of the sander may tend to become unsteady after new sanding paper has been installed, because of the new, coarse grain of the paper. This can be avoided by slightly tilting the sander forward or backward during sanding or polishing. Sander movement will become steady as the sanding paper surface becomes properly abraded.



Figs. 5

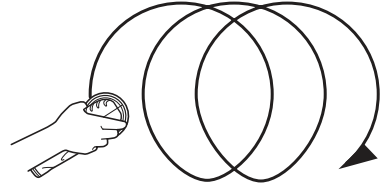

Figs. 6

MOUNTING THE OPTIONAL ACCESSORIES

- Mounting the polyester buff
Since the attachment is a hook-and-loop type as with the sanding paper, the polyester buff can be mounted by just pressing it onto the pad (**Fig. 7**).

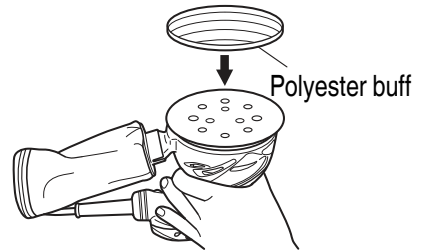

Fig. 7

MAINTENANCE AND INSPECTION

- Emptying and cleaning the Dust Bag
If the dust bag contains too much saw dust, dust collection will be affected. Empty the dust bag when it gets full.
Remove the dust bag, open the fastener, and dispose of the contents.
- Inspecting the sanding paper
Since use of worn-out sanding paper will degrade efficiency and cause possible damage to the pad, replace the sanding paper as soon as excessive abrasion is noted.
- Inspecting the mounting screws
Regularly inspect all mounting screws and ensure that they are properly tightened. Should any of the screws be loose, retighten them immediately. Failure to do so could result in serious hazard.
- Maintenance of the motor
The motor unit winding is the very "heart" of the power tool.
Exercise due care to ensure the winding does not become damaged and/or wet with oil or water.

5. Servicing
Consult an authorized Service Agent in the event of power tool failure.
6. Service parts list

CAUTION

Repair, modification and inspection of HiKOKI Power Tools must be carried out by a HiKOKI Authorized Service Center.

This Parts List will be helpful if presented with the tool to the HiKOKI Authorized Service Center when requesting repair or other maintenance.

In the operation and maintenance of power tools, the safety regulations and standards prescribed in each country must be observed.

SERVICE PARTS LIST

SV13YA

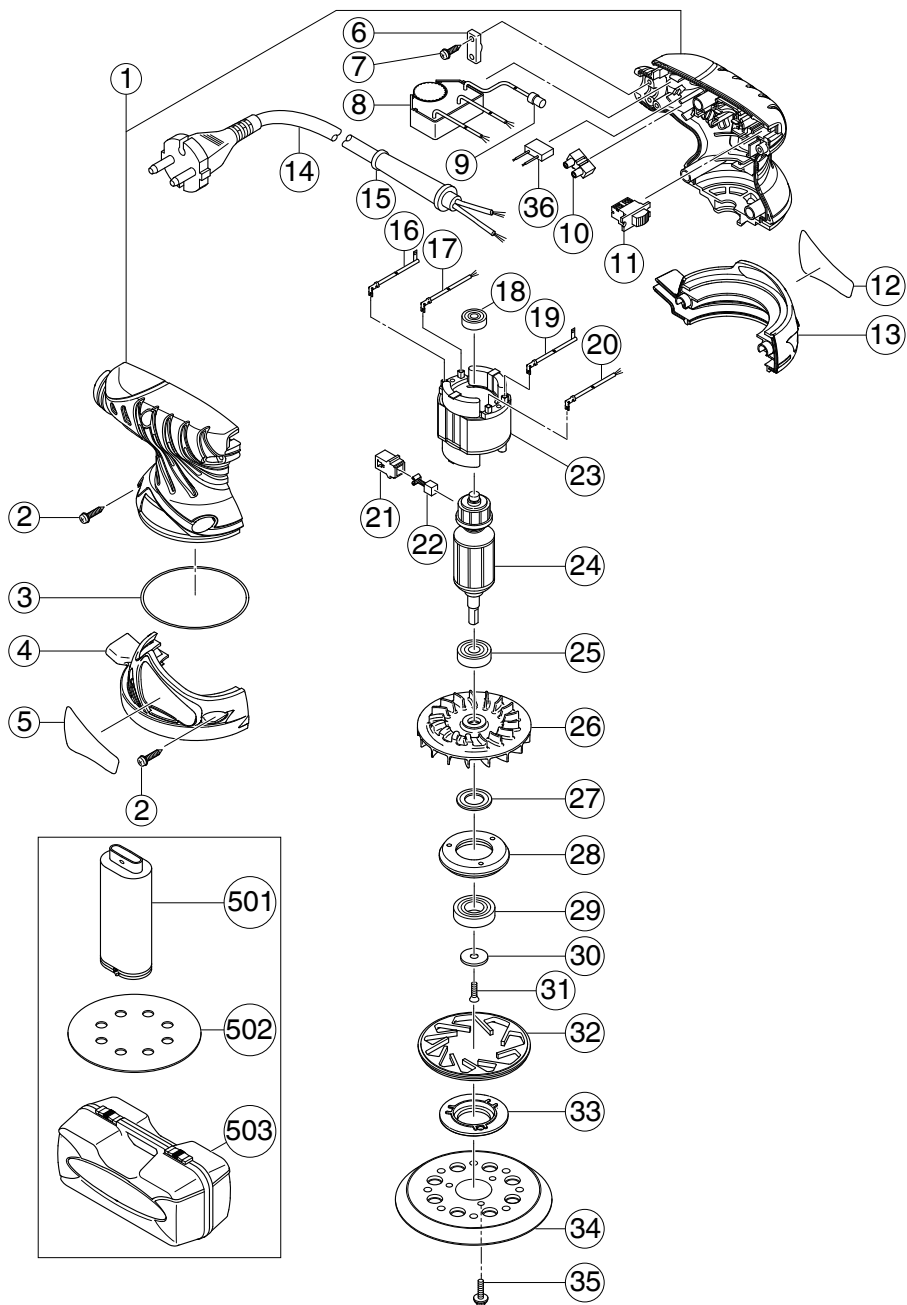

Item No.	Code No.	No. Used	Remarks
1	324-249	1	
2	301-653	7	D4 x 20
3	993-195	1	
4	324-207	1	
5	_____	1	
6	937-631	1	
7	984-750	2	D4 x 16
8	324-248	1	220V
9	959-140	1	
10	938-307	1	
11	311-948	1	
12	_____	1	
13	324-206	1	
14	500-439Z	1	
15	953-327	1	D8.8
16	322-764	1	
17	322-761	1	
18	626-VVM	1	626VVC2PS2L
19	322-763	1	
20	322-762	1	
21	930-483	2	
22	999-041	2	
23	340-616E	1	220V-230V
24	360-696E	1	220V-230V
25	629-VVM	1	629VVC2PS2L
26	324-521	1	
27	324-208	1	
28	324-212	1	
29	600-2DW	1	6002DDWCMP2L
30	309-422	1	
31	993-244	1	M4 x 12
32	324-210	1	
33	324-211	1	
34	324-209	1	
35	307-109	3	M4 x 16
36	930-039	1	
501	310-339	1	
502	308-519	1	A-P120
503	324-613	1	

Item No.	Code No.	No. Used	Remarks
1	324-214	1	
2	301-653	7	D4 x 20
3	993-195	1	
4	324-207	1	
5	_____	1	
6	984-750	2	D4 x 16
7	937-631	1	
8	930-039	1	
9	938-307	1	
10	311-948	1	
11	_____	1	
12	324-206	1	
13	500-468Z	1	
14	953-327	1	D8.8
15	322-764	1	
16	322-761	1	
17	626-VVM	1	626VVC2PS2L
18	322-763	1	
19	322-762	1	
20	930-483	2	
21	999-041	2	
22	340-618E	1	220V-230V
23	360-698E	1	220V-230V
24	629-VVM	1	629VVC2PS2L
25	324-521	1	
26	324-208	1	
27	324-212	1	
28	600-2DW	1	6002DDWCMP2L
29	309-422	1	
30	993-244	1	M4 x 12
31	324-210	1	
32	324-211	1	
33	324-209	1	
34	307-109	3	M4 x 16
501	310-339	1	
502	308-519	1	A-P120

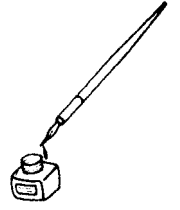

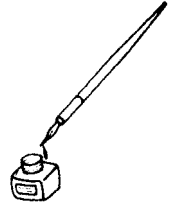

服务中心
高壹工机商业(上海)有限公司
上海市闵行区浦江工业园区三鲁路3585号7幢3楼

制造商
福建高壹工机有限公司
福建省福州市福兴投资区湖塘路

Koki Holdings Co., Ltd.

109
编号: C99138927 F
发行日期: 2021年 9月
中国印刷