

HiKOKI

中文

English

滑动复合式斜口锯
Slide Compound Miter Saw

C 12RSH3

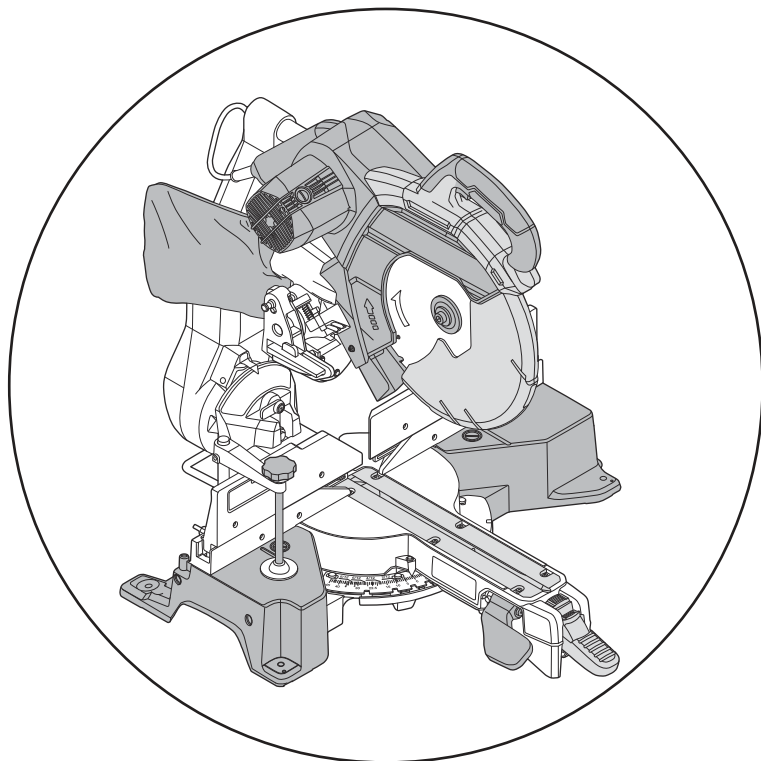

保留备用
Keep for future reference



使用说明书
Handling instructions



目次

电动工具通用安全警告.....	2
斜口锯的安全说明.....	4
使用滑动复合式斜口锯的注意事项.....	6
符号.....	8
零件名称.....	10
规格.....	11
标准附件.....	13
用途.....	13
作业之前.....	14
切割之前.....	18
实际应用.....	24
安装和拆卸锯条.....	36
主体的运输.....	38
维护和检查.....	39
故障排除.....	41
选择附件.....	43

电动工具通用安全警告

警告！

阅读电动工具附带的所有安全警告、说明、插图和规格说明。
不遵照以下说明会导致电击、着火和 / 或严重伤害。

保存所有警告和说明书以备查阅。

在所有下列的警告中术语“电动工具”指市电驱动（有线）电动工具或电池驱动（无线）电动工具。

1) 工作场地的安全

- a) 保持工作场地清洁和明亮。
混乱和黑暗的场地会引发事故。
- b) 不要在易爆环境，如有易燃液体、气体或粉尘的环境下操作电动工具。
电动工具产生的火花会点燃粉尘或气体。
- c) 让儿童和旁观者离开后操作电动工具。
注意力不集中会使操作者失去对工具的控制。

2) 电气安全

- a) 电动工具插头必须与插座相配。绝不能以任何方式改装插头。需接地的电动工具不能使用任何转换插头。
未经改装的插头和相配的插座将减少电击危险。
- b) 避免人体接触接地表面，如管道、散热片和冰箱。
如果你身体接地会增加电击危险。
- c) 不得将电动工具暴露在雨中或潮湿环境中。
水进入电动工具将增加电击危险。
- d) 不得滥用电线。绝不能用电线搬运、拉动电动工具或拔出其插头。使电线远离热源、油、锐边或运动部件。
受损或缠绕的软线会增加电击危险。
- e) 当在户外使用电动工具时，使用适合户外使用的外接软线。
适合户外使用的软线将减少电击危险。
- f) 如果在潮湿环境下操作电动工具是不可避免的，应使用剩余电流动作保护器（RCD）。
使用RCD可减小电击危险。

3) 人身安全

- a) 保持警觉，当操作电动工具时关注所从事的操作并保持清醒。当你感到疲倦，或在有药物、酒精或治疗反应时，不要操作电动工具。
在操作电动工具时瞬间的疏忽会导致严重人身伤害。
- b) 使用个人防护装置。始终佩戴护目镜。
安全装置，诸如适当条件下使用防尘面具、防滑安全鞋、安全帽、听力防护等装置能减少人身伤害。
- c) 防止意外起动。确保开关在连接电源和 / 或电池盒、拿起或搬运工具时处于关断位置。
手指放在已接通电源的开关上或开关处于接通时插入插头可能会导致危险。
- d) 在电动工具接通之前，拿掉所有调节钥匙或扳手。
遗留在电动工具旋转零件上的扳手或钥匙会导致人身伤害。
- e) 手不要伸展得太长。时刻注意立足点和身体平衡。
这样在意外情况下能很好地控制电动工具。
- f) 着装适当。不要穿宽松衣服或佩戴饰品。让你的头发和衣服远离运动部件。
宽松衣服、佩饰或长发可能会卷入运动部件中。
- g) 如果提供了与排屑、集尘设备连接用的装置，要确保它们连接完好且使用得当。
使用这些装置可减少尘屑引起的危险。
- h) 请勿因频繁使用工具的熟悉感而掉以轻心，忽视工具的安全性原则。
粗心的行为可能会导致瞬间发生严重伤害。

4) 电动工具使用和注意事项

- a) 不要滥用电动工具，根据用途使用适当的电动工具。
选用适当设计的电动工具会使你工作更有效、更安全。
- b) 如果开关不能接通或关断工具电源，则不能使用该电动工具。
不能用开关来控制的电动工具是危险的且必须进行修理。
- c) 在进行任何调整、更换附件或存放电动工具之前，必须从电源上拔掉插头和 / 或取下电池盒（如果可拆卸）。
这种防护性措施将减少工具意外起动的危险。
- d) 将闲置不用的电动工具贮存在儿童所及范围之外，并且不要让不熟悉电动工具或对这些说明不了解的人操作电动工具。
电动工具在未经培训的用户手中是危险的。
- e) 维护电动工具和附件。检查运动件是否调整到位或卡住，检查零件破损情况和影响电动工具运行的其他状况。如有损坏，电动工具应在使用前修理好。
许多事故由维护不良的电动工具引发。
- f) 保持切削刀具锋利和清洁。
保养良好的有锋利切削刃的刀具不易卡住而且容易控制。
- g) 按照使用说明书，考虑作业条件和进行的作业来使用电动工具、附件和工具的刀头等。
将电动工具用于那些与其用途不符的操作可能会导致危险。
- h) 保持手柄和抓握表面干燥、清洁，远离油和油脂。
如果手柄和抓握表面湿滑，可能导致在发生意外情况时，无法安全操作和控制工具。

5) 维修

- a) 将你的电动工具送交专业维修人员，使用同样的备件进行修理。
这样将确保所维修的电动工具的安全性。

注意！

不可让儿童和体弱人士靠近工作场所。

应将不使用的工具存放在儿童和体弱人士接触不到的地方。

斜口锯的安全说明

1. 斜口锯用于切割木材或木材类似品，请勿与切割砂轮搭配用以切割铁质材料，如杆件、棒材、螺柱等。
磨屑会导致下护罩等移动部件卡住。磨削切割会产生火花，烧毁下护罩、切口插入件和其他塑料部件。

2. 尽可能使用夹扣来支撑工件。如果用手支撑工件，须始终保持手与锯片两侧相距至少100mm。请勿使用本锯来切割无法牢固夹紧或手持的过小工件。
如果手与锯片靠得太近，会增加与锯片接触而受伤的风险。
3. 工件务必保持不动，夹紧或抵在挡板和工作台上。不得以任何“徒手”的方式将工件送入锯片中或进行切割。
未固定或移动的工件可能会被高速抛出，导致受伤。
4. 将斜口锯推过工件。请勿将斜口锯拉过工件。如要切割，请在不切割的状态下抬起锯头并拉出至工件上方，启动电机，按下锯头并将斜口锯推过工件。
在回拉行程中进行切割时，很可能导致锯片上升到工件顶部并将锯片组件猛地抛向操作者。
5. 无论在锯片的前方还是后方位置，切不可将手横过预定切割线。
以“交叉手”方式支撑工件（即，用左手将工件靠于锯片右侧）非常危险，反之亦然。
6. 当锯片仍在旋转时，请勿将任何一只手伸到距离锯片两侧100mm以内的挡板后方清理木屑或出于任何其他原因进行操作。
旋转中的锯片与手的接触距离可能不明显，因此可能会造成人员严重受伤。
7. 切割前，请检查工件。如果工件弯曲或卷翘，将其夹紧，使外侧弯曲面向挡板。务必确保工件、挡板和工作台之间沿着切割线的部分无间隙。
弯曲或卷翘的工件可能扭曲或移位，并可能在切割时导致瓷砖锯的旋转锯片上出现粘连。工件内不得有铁钉或异物。
8. 工作台上除了工件外，不得有任何其他工具、木屑等，否则请勿使用本锯。
接触旋转刀片的小切屑或松散的木片或其他物体可能会被高速抛出。
9. 一次仅切割一个工件。
叠放的多个工件无法充分夹紧或抵牢，可能会在切割过程中粘在刀片上或发生移位。
10. 使用前，确保斜口锯安装或放置在平坦稳固的工作表面上。
平坦稳固的工作表面会降低斜口锯变得不稳定的风险。
11. 筹划工作。每次更改斜角或斜接角度设定时，请确保用于支撑工件的可调挡板固定稳妥，且不会干扰刀片或防护系统。
在未打开工具且工作台上无工件的情况下，请移动锯片进行完整的模拟切割，以确保切割挡板时不存在干扰或危险。
12. 为宽于或长于台面的工件提供足够的支撑，如工作台延伸部分、锯木架等。
如果支撑不稳，宽于或长于斜口锯工作台的工件可能会倾斜。如果切割件或工件倾斜，其可能会支起下护罩或被旋转刀片抛出。
13. 不可由他人来充当工作台延伸部分的替代物或作为额外的支撑物使用。

工件如未作稳定支撑，会导致切割操作过程中发生刀片粘连或工件移位，将您和协作者拉入旋转的刀片中。

14. 切割件不得以任何方式卡住或压在旋转的锯片上。
如进行限制（即，使用长度挡块），切割件可能会楔住刀片并猛地抛出。
15. 始终使用夹扣或固定装置来正确支撑杆或管之类的圆形材料。
在切割时，杆易于滚动，导致刀片“咬住”进行作业的手并将其拉入刀片内。
16. 接触工件前，让刀片达到全速。
这会降低工件被抛出的风险。
17. 如果工件或锯片被卡住，请关闭斜口锯。等所有移动部件停止后，从电源上断开插头和/或取出电池组。然后释放被卡住的材料。
如果在工件被卡住的情况下继续锯切，将导致斜口锯失控或损坏。
18. 切割结束后，松开开关，按下锯头并等待刀片停止，然后移除切割件。
将手伸到滑动刀片附近极为危险。
19. 当进行不完全切割或在锯头完全处于下方位置之前松开开关时，请握紧手柄。
斜口锯的制动动作可能会导致锯头突然被下拉，从而导致受伤的风险。

使用滑动复合式斜口锯的注意事项

1. 机器周围的地面应保持水平。维护良好且无松散的物料，如碎屑与切片。
2. 保证充足的总体或局部照明。
3. 请勿将本电动工具用于使用说明书中所规定之外的其他用途。
4. 维修仅能由有资格的维修人员进行。制造厂商对因非专业维修人员进行维修及使用不当而造成的损坏和损伤概不负责。
5. 为了保证设计的完整性，电动工具的盖罩和螺钉类不可随便拆除。
6. 除非电线插头已从电源插座拆下，绝不可接触转动部分或附件。
7. 应以低于铭牌上的额定输入功率进行作业。否则电动机将过载而影响工作精度，并降低效率。
8. 请勿使用溶剂擦拭塑料部件。因为：汽油、冲淡剂、轻质汽油、四氯化碳、酒精等都会使塑料损伤或发生龟裂，所以应避免使用。请勿使用上述溶剂进行擦拭。擦拭塑料制品，可以使用稍微沾湿了肥皂水的柔布。
9. 只能使用HiKOKI指定的更换零件。
10. 本电动工具只在更换炭刷时才可拆解。
11. 切勿切割铁金属或砖瓦材料。
12. 提供充足的总体或局部照明。原料与成品工件应位于操作员的正常工作位置附近。

13. 必要时应使用适当的个人防护设备，可包括：听力保护，以减少听力受损的风险。
眼部保护，以减少眼睛受伤的风险。
呼吸保护，以减少吸入有害灰尘的风险。
手套，用于操作锯条（移动锯条时应尽可能把锯条放在支架中）以及粗糙材料。
14. 操作员应接受机器使用、调节与操作方面的充分培训。
15. 在机器运行且锯头未处于停止位置时，不得从切割区域移去工件的任何切片或其他部分。
16. 请勿在锯片转向前面或转向侧面的状态下使用滑动复合式斜口锯。
17. 确保下护罩能够平滑地移动。
18. 安全罩未处于正常位置时请勿使用复合锯，要在其工作状态良好且得到正确的维护的情况下使用。
19. 使用经过正确磨快的锯条。注意锯条上标注的最大速度。
20. 锯条破损或变形时请勿使用。
21. 不要使用以高速钢材制造的锯条。
22. 请仅使用HiKOKI公司所推荐的锯条。
23. 锯条的外径应在305mm。
24. 须根据要切割的材料来选择锯条。
25. 请勿在锯片朝上或朝侧面的情况下操作滑动复合式斜口锯。
26. 确保工件上无任何异物（如铁钉等）。
27. 导板磨损时请予更换。
28. 请勿使用锯条切割铝材、木材或类似材料以外的材料。
29. 请仅使用制造商所推荐的复合锯切割材料。
30. 锯片更换步骤，包括重新放置的方法以及务必正确进行此步骤的警告。
31. 在切割木头时，将滑动复合式斜口锯与集尘装置相连接。
32. 开槽时要小心。
33. 搬运此电动工具时，请勿抓住其支架。应抓住手柄而不要抓住支架。
34. 须在电动机达到最大转速时才开始切割。
35. 发现异常情况时应迅速断开开关。
36. 在切断电源并等到锯条停止之后，方可对工具进行维修或调整。
37. 在进行斜接切割或斜角切割中，在锯条完全停止转动之后，方能升高锯条。
38. 进行切割作业时，操作员必须将锯条朝外推。
39. 请充分考虑切割操作中所有可能涉及的剩余风险，如意外接触到机器上滑动机械部件的移动部件等。
40. 确保每次切割之前，机器保持平稳。
仅使用最大允许速度高于电动工具空载速度的锯条。
请勿替换为其他类型的LED灯。

中文

41. 请勿站在机器前面，与锯条在一条直线上。始终站在锯条旁边。这将保护您的身体避免发生机器误伤风险。保持手、手指和手臂远离正在旋转的锯条。
操作工具臂时请勿交叉双臂。
42. 务必关闭机器并让锯条完全停止，然后再拿起工件，否则可能导致锯条被卡住。为防止反向弹出，等机器完全停止后再移动工件。
重新启动机器前，清除可能会导致锯条卡住的因素。
43. 当锯头向下时，切勿松开握持手柄的手。
否则可能会使锯头弹起，导致工具掉落，并可能造成人员受伤。
44. 操作时请确保牢牢握住工具。否则可能导致事故或受伤。（图1）







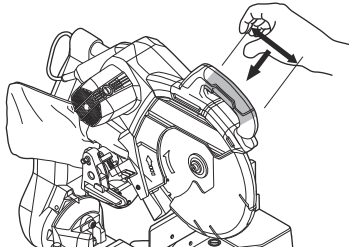

图1

符号

警告！

如下所示的符号用于本机。使用前请务必理解其含意。

	为降低伤害风险，用户必须阅读使用说明书
	请勿凝视操作灯。
	始终佩戴护目镜。
	保证作业全程佩戴耳罩。
V	额定电压
A	电流
W	瓦特

n_0	空载转速
/min	每分钟转数
	二类工具
	警告

零件名称



图2



图3

规格

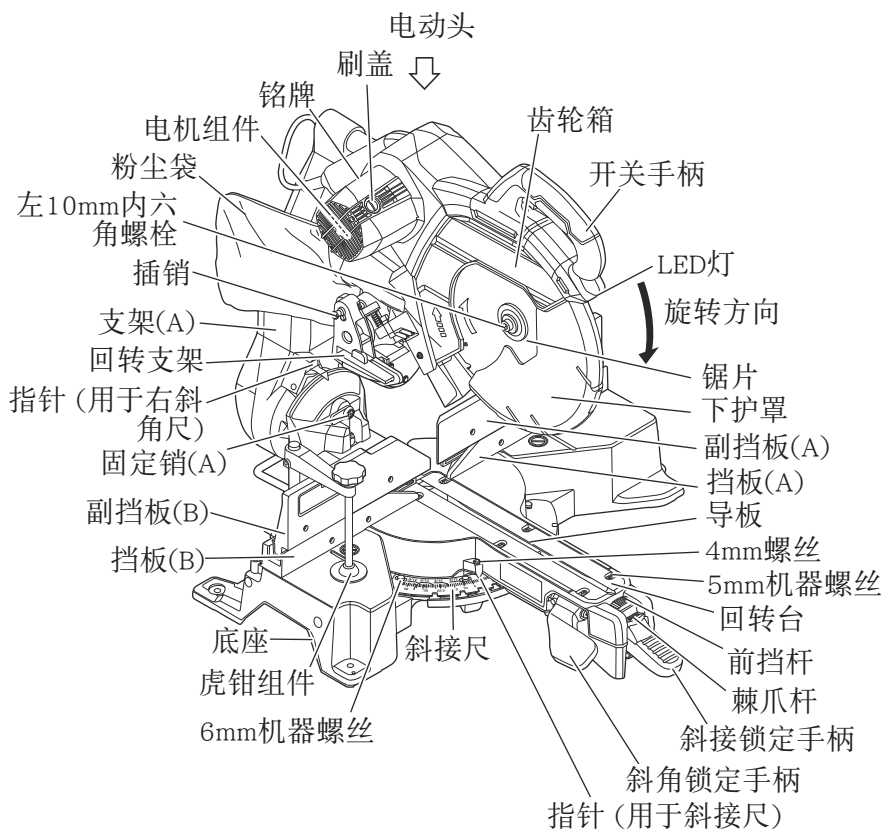
型式	C 12RSH3	
电机	类型	系列整流式电动机
	电压	220V
	输入功率	1520W
LED灯	有	
适用锯条	外径 305mm 孔径 25.4mm	
空载速度	4000/min	
斜接锯切范围	左 0° - 45° 右 0° - 57°	
斜角锯切范围	左 0° - 45° 右 0° - 45°	
复合锯切范围	左 (斜角) 0° - 45°	左 (斜接) 0° - 45° , 右 (斜接) 0° - 45°

中文

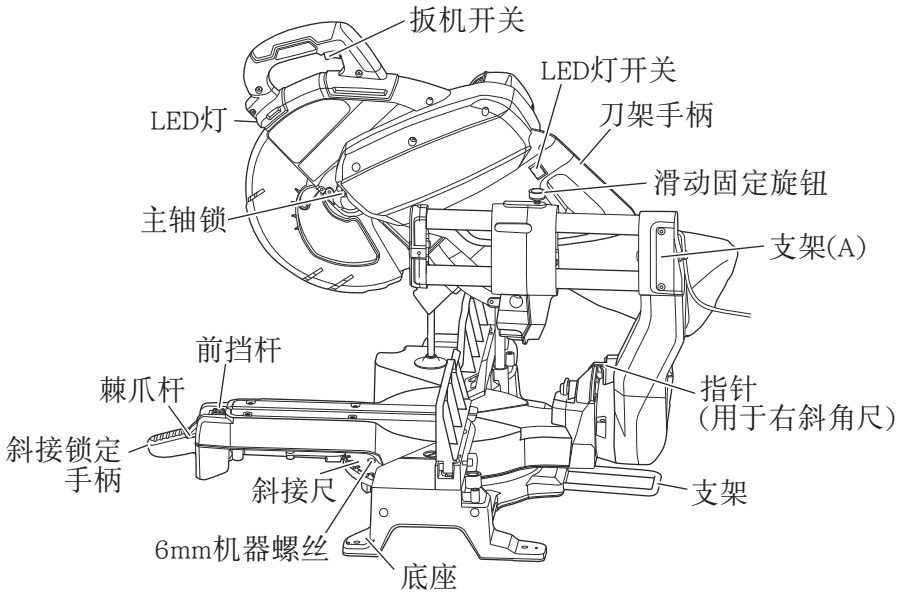
复合锯切范围	右（斜角） 0° - 45°	右（斜接）0° - 45°， 左（斜接）0° - 45°
净重*1	24.3kg	
电线	双芯电缆 1.8m	

*1 不包括锯片的重量。

表1: 最大锯切尺寸





	主体	回转台	最大锯切尺寸		
			最大高度	最大宽度	连同辅助板
斜接	0	0	107mm	312mm	-
			*120mm	260mm	25mm
		左 45° 或 右 45°	107mm	220mm	-
			*120mm	180mm	25mm
		右 57°	107mm	170mm	-
			*120mm	130mm	25mm
斜角	左 45°	0	70mm	312mm	-
			*75mm	260mm	25mm
	右 45°	0	45mm	312mm	-
			*50mm	260mm	25mm
复合	左 45°	左 45°	70mm	220mm	-
			*75mm	180mm	25mm
		右 45°	70mm	220mm	-
			*75mm	180mm	25mm
	右 45°	左 45°	45mm	220mm	-
			*50mm	180mm	25mm
		右 45°	45mm	220mm	-
			*50mm	180mm	25mm

在切割“*”尺寸的工件时，即使将电动头置于下限位置，也务必使圆锯的下端能够接触工件。切割工件时务必谨慎。有关详情，请参见第24页的“实际应用”。将辅助板安装在挡板表面请参见第27页的“6. 切割大工件”（第27页的图23）。

标准附件

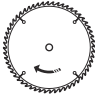
除了主机（1台）外，产品包中还包括表中所列的附件。

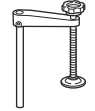
表2

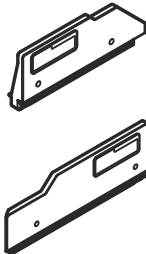
	305mm TCT 锯条（安装在工具上）	1
	粉尘袋	1
	8mm内六角扳手	1
	虎钳组件	1
	支架	1
	副挡板（安装在工具上）	1

用途

切割各种类型的铝框格和木材。

作业之前

警告！

在将电源插头插入插座前，进行必要的调整。

1. 电源

确认所使用的电源与产品铭牌上标示的功率要求相符。

请勿使用直流电或增压机等变压器。否则可能会导致机器损坏或事故。

2. 电源开关

确认电源开关已切断。若触发器开关接通，则插头插入电源插座时电动工具将出其不意地立刻转动，从而导致严重事故。

3. 延伸线缆

当工作区域距离电源较远时，使用足够厚度和额定功率的延伸线缆。延伸线缆应尽可能短。

4. 取下所有粘贴或连接到该工具的包装材料，然后再次尝试操作。

5. 安装（图4）

确认机器始终固定在工作台上。将该电动工具安装到水平的工作台上。选择适合工作台厚度的8mm直径螺栓。

螺栓长度至少应为40mm加上工作台厚度。

例如，对于25mm厚的工作台，应使用8mm×65mm螺栓。



图4

6. 调节底座 (图5)

使用10mm套筒扳手拧松6mm螺栓。调节底座直至其底面接触到工作台或地面。

调节后，拧紧6mm螺栓。

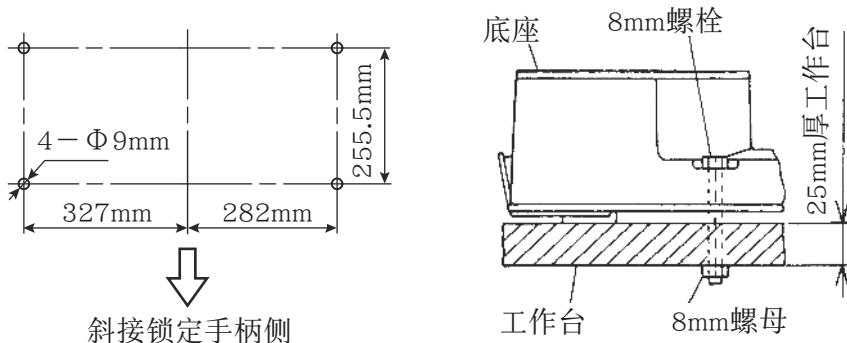

图5

7. 松开锁定插销 (图6)

当准备运输电动工具时，其主要部件须用锁定插销固定。

轻轻按下手柄并拔出锁定插销，以松开切割头。

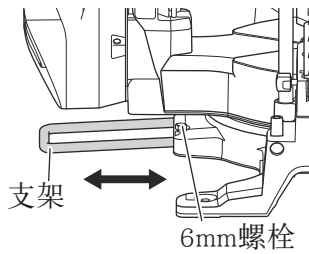
在运输过程中，将锁定插销插入齿轮箱进行固定。



图6

8. 安装集尘袋、止动片和虎钳 (止动片为选购件。)

(1) 安装集尘袋 (图7)

将集尘袋安装到斜口锯的集尘口。

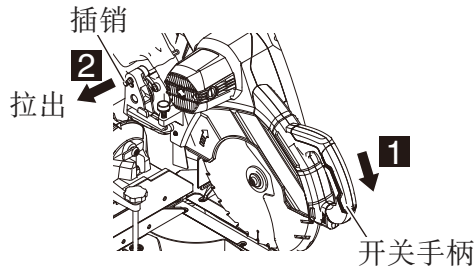
将集尘袋的连接管和集尘口连接起来。

中文

如要清空集尘袋，请从集尘口拉出集尘袋组件。拉开集尘袋下部的拉链，倾倒入垃圾箱中。经常进行检查，并在集尘袋装满前清空。进行斜角切割时，请调整支撑杆并安装集尘袋，使其垂直下挂。



图7

警告！

请勿使用该锯来切割和/或打磨金属。滚烫的碎屑或火花可能会点燃袋材上的锯屑。

注意！

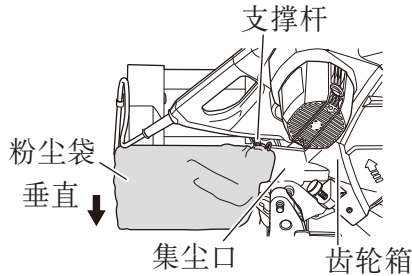
- 经常清空集尘袋，以防管道和下护罩被卡住。在斜角切割过程中，锯屑会较平时积聚得更快些。
- 在切割木材后，开始切割铝制窗扇前，请废弃集尘袋中的碎屑。

（连接虎钳组件，如第26页的图20所示；连接止动片，如第33页的图29所示。）

9. 检查下护罩是否操作无误

警告！

如果下护罩未顺畅运行，切勿操作电动工具。

下护罩用于在工具操作过程中对操作者进行保护，以避免接触锯片。务必检查下护罩是否移动顺畅，并盖好锯片。（图8）



图8

10. 斜角

警告！

改变倾斜角度时，请压低电动头。如果电动头突然移动到某个倾斜的角度，可能会导致人员受伤或主体损坏。

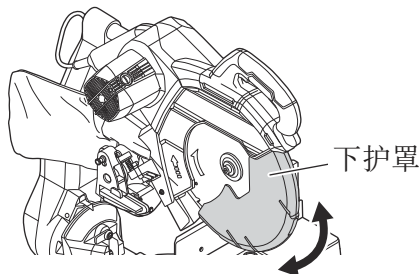
电动工具在出厂装运之前，已使用8mm固定螺丝调整为 0° 、直角、左 45° 斜角切割角度和右 45° 斜角切割角度。

变更调整时，通过转动8mm固定螺丝变更其高度。（图9-a、图9-b）

将斜角改为左 45° 时，拧松第21页的图13所示的6mm翼栓，然后向外滑动副挡板（B），使电动头向左倾斜。

将斜角改为右 45° 时，向外移动副挡板（A）并松开斜角锁定手柄，然后向前拉出固定销（A），并向右倾斜电动头。（图9-b）

当电动头直立时，固定销（A）被紧固到位，因此在向右倾斜电动头之前，拔出固定销（A）时，将电动头稍微向左倾斜。

将电动头调整至 0° 时，务必将固定销（A）返回至其初始位置，如图9-b所示。



图9

中文

11. 检查锯条的下限位置

检查锯条是否可以降低到导板以下9mm至11mm。更换新锯条时，请按照锯条不会切割到回转台或无法进行完整切割的原则调节下限位置。如需调节锯条的下限位置，请遵循下列第(1)步。(图10)

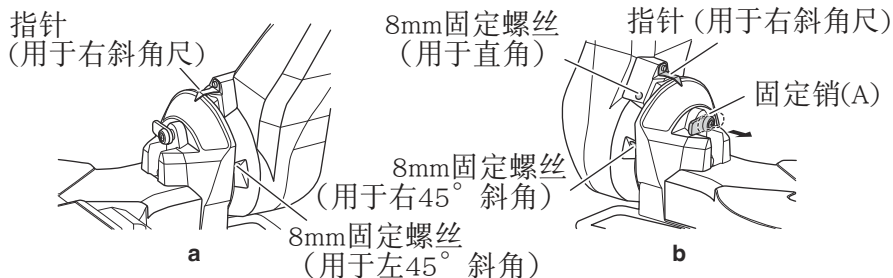
- (1) 转动8mm深度调节螺栓，改变螺栓头和回转支架接触位置的高度，然后调节锯条的下限位置。

注:

确认调节的锯条不会切割到回转台。



图10

切割之前

1. 放置导板

导板安装在回转台上。出厂装运工具时，按照锯条不会与导板接触的原则固定导板。如果按照导板侧面和锯条的间隙为最小的原则固定导板，则台面工件底面的嗡嗡声将会明显降低。使用工具之前，请按照下列步骤消除该间隙。

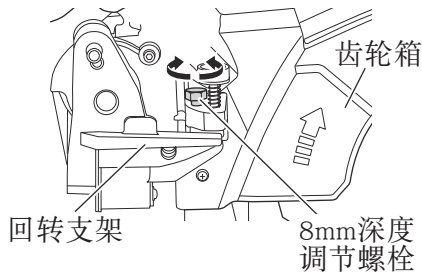
(1) 直角切割 (图11-a)

松开三颗5mm机器螺丝，然后固定左侧导板并暂时旋紧两端的5mm机器螺丝。然后使用虎钳组件固定工件（宽度约为200mm）并将其切除。将切割表面与导板边缘对齐之后，牢牢旋紧两端的5mm机器螺丝。取出工件并牢牢旋紧5mm中央机器螺丝。按照相同的方式调节右侧导板。



图11-a

(2) 左右斜角切割 (图 11-b, 图11-c)

按照直角切割的同样的步骤来调节导板。

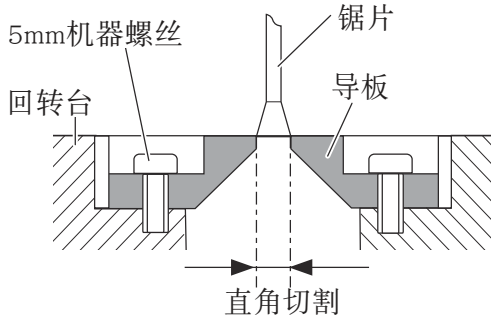

图 11-b



图11-c

注意！

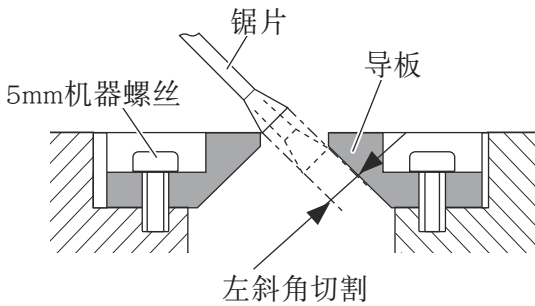
将导板调节于进行直角切割之后，如果用于斜角切割，则导板将被部分切除。
需要斜角切割操作时，请调节导板进行斜角切割。

2. 确认使用副挡板（A）（图12）

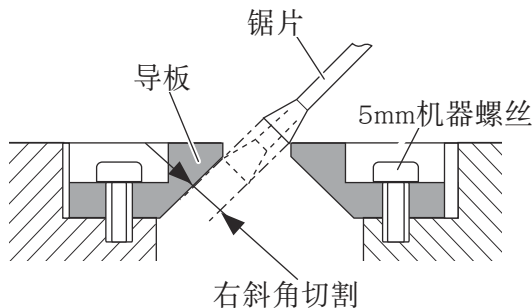
警告！

右斜角切割时，拧松6mm翼栓，然后向外滑动副挡板（A）并取下。否则主体或锯条可能与副挡板（A）接触，从而导致损伤。

本电动工具配备副挡板（A）。进行直接角度切割和左斜角切割时，请使用副挡板（A）。这样就可以实现对具有宽大背面的材料进行稳定的切割。

注意！

进行直接角度切割和左斜角切割时，向内滑动到副挡板（A）碰到的位置，并用6mm翼形螺栓固定。（如图12所示）



图12

3. 确认使用副挡板（B）（图13）

警告！

进行左斜角切割时，拧松6mm翼栓，然后向外滑动副挡板（B）。否则主体或锯条可能与副挡板（B）接触，从而导致损伤。

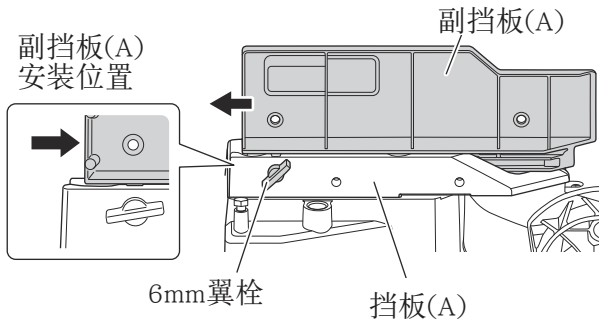
本电动工具配备副挡板（B）。进行直接角度切割和右斜角切割时，请使用副挡板（B）。这样就可以实现对具有宽大背面的材料进行稳定的切割。

注意！

进行直接角度切割和右斜角切割时，向内滑动到副挡板（B）碰到的位置，并用6mm翼形螺栓固定。（如图13所示）



图13

4. 滑动刀架系统（图14）

警告！

为了降低人员受伤的风险，在每次横切操作后，请将滑动刀架返回到最后端的位置。

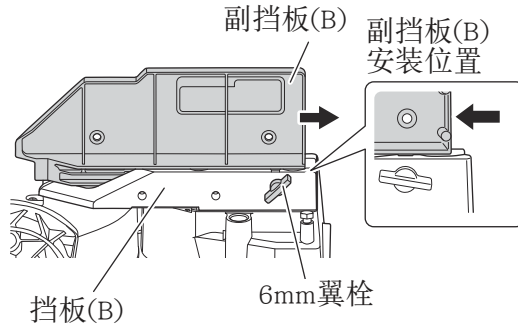
对于小工件的切碎操作，请将切割头组件完全滑向装置后部，并拧紧滑动固定旋钮。要切割宽度达312mm的木板时，请务必松开滑动固定旋钮，让切割头自由滑动。（图14）



图14

5. 斜接尺调整

- 降低头部，插入锁定插销。

解锁斜接锁定手柄并旋转回转台，直至前挡块将其锁定在 0° 的斜接位置。

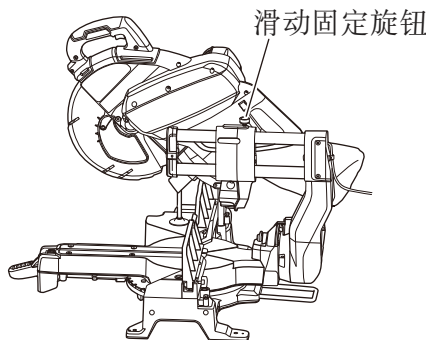
请勿锁定斜接锁定手柄。请在锯的挡板和锯片上放置一把角尺，如图15所示。（请勿用角尺接触刀齿尖。否则会导致测量不准确。）

如果锯片不完全垂直于挡板，请拧松固定斜接尺的6mm机器螺丝（4颗），并向左或向右移动斜接锁定手柄和斜接尺，直至刀片垂直于挡板，如用角尺测量一般。

重新拧紧6mm机器螺丝（4颗）。（图15）

此时请忽略指针的读数（用于斜接尺）。

○ 指针（用于斜接尺）调整

解锁斜接锁定手柄，将回转台移动到 0° 的位置。在斜接锁定手柄解锁的情况下，将回转台旋转至 0° 时，请允许前挡块卡入到位

观察指针（用于斜接尺）和斜接尺，如图15所示。指针（用于斜接尺）如未准确地指示 0° ，请拧松固定指针（用于斜接尺）的4mm螺丝。将指针（用于斜接尺）重新放置到位并拧紧4mm螺丝。



图15

6. 斜接角度调整

滑动复合式斜口锯的斜接尺会显示从 0° 到 45° 的左右斜切角度，易于读取。斜口锯工作台有九种最常见的角度设定，前挡块分别位于 0° 、 15° 、 22.5° 、 31.6° 和 45° 的位置。此类前挡块可准确快速地将刀片定位在所需的角度的。遵循以下过程，进行最准确快速的调整。（图16）

调整斜接角度：

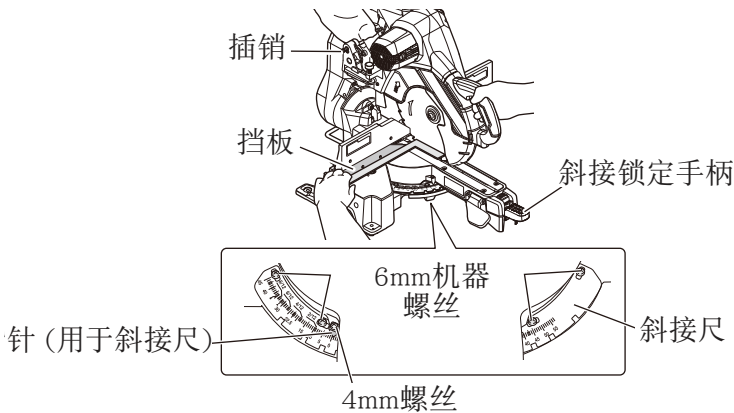
- (1) 向上推斜接锁定手柄，释放回转台。
- (2) 向下推前挡杆直至搭上棘爪杆，以释放“前挡块”。

- (3) 旋转回转台，并将指针设定为与所需的斜接尺角度对齐。此时，当使用前挡块功能时，如图 16 所示，在所需角度附近沿箭头方向拉动棘爪杆将其释放，并通过前挡块功能移动回转台，将其固定到所需的角位置。
(0° 、 15° 、 22.5° 、 31.6° 和 45°)

- (4) 按下斜接锁定手柄，将回转台固定到位。

棘爪杆 (图 16)

棘爪杆允许工作台进行微调，解除前挡块止动功能。当所需的斜接角度接近前挡块时，该棘爪杆会防止前挡杆上的楔块滑入底座的止动槽中。



图 16

7. LED照明系统 (图17) [XACT CUT LED™]

注意！

请勿凝视操作灯。凝视光束可能会导致严重伤害或视力丧失。

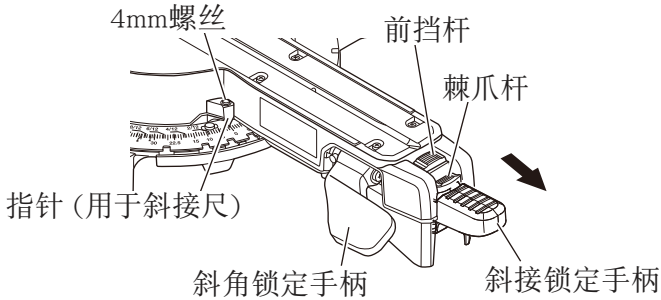
LED照明系统[XACT CUT LED™]将刀片的影子投射到工件上。这有助于切割更精确且无需调整。

要使用此功能，请打开LED灯的开关。

垂下电动头，使刀片距工件约6mm。这会将刀片的影子投射到工件上，指示切割时刀齿将接触的位置。



图17

实际应用

警告！

- 为避免人员受伤，使用工具时切勿从台上移走工件或把工件放在台上。
- 使用工具时切勿使四肢进入警告标志旁边的线内（见图18。否则可能发生危险。

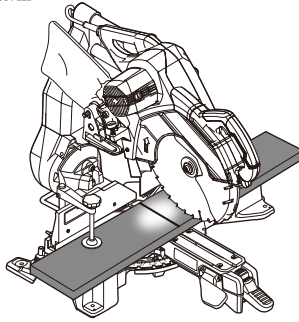

图18

注意！

- 锯条正在转动时拆除或安装工件是非常危险的。
- 切割时，从回转台清除锯末。
- 如果锯末积累太多，会从切割材料中露出锯条。请勿将您的手或其他任何东西放到裸露的刀片附近。

1. 开关操作

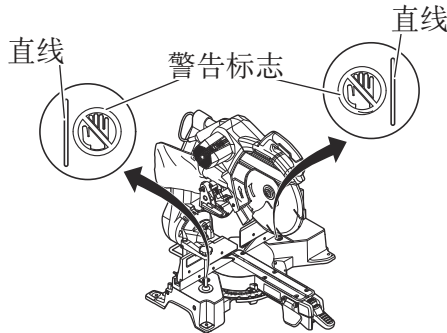
拉动触发器打开开关。松动触发器便可将其关闭。（图19）

打开开关后，即使松开开关锁，只要拉动开关，锯片也依然继续旋转。

松开开关时，制动器作用于锯片旋转，使锯片停止。



图19

2. 打开LED灯

按下LED灯开关，打开LED灯。

3. 使用虎钳组件（标准附件）（图20）

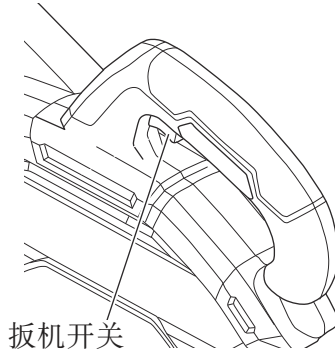
警告！

尽可能使用夹扣来支撑工件。如果用手来支撑工件，须始终保持手与锯片两侧相距至少100mm。请勿使用本锯来切割无法牢固夹紧或手持的过小工件。

如果您的手与锯片靠得太近，会增加与锯片接触而受伤的风险，且工件可能会从工作台上被掷出，造成身体伤害。

注意！

降低进行切割时，须确保电动头不与虎钳组件接触。如果有可能碰到，将虎钳组件移到不会碰到锯片的位置。

(1) 可将虎钳组件安装在底座上。

(2) 转动上旋钮并将工件牢牢固定到位。(图20)



图20

注:

使用虎钳时, 请确保在装置摆动或滑动时, 虎钳工具不与其产生任何过度接触。

4. 切割操作

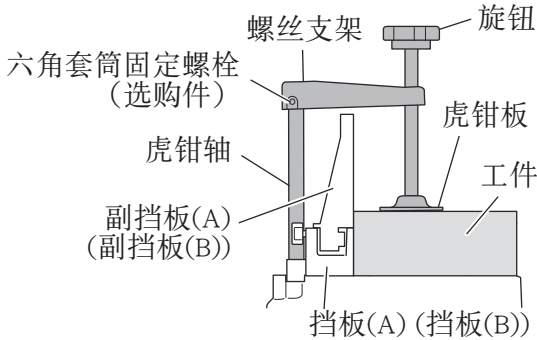
(1) 如图21所示, 锯条的宽度为切割宽度。因此, 在需要长度**ⓑ**时将工件向右侧滑动(从操作员的位置看去), 或在需要长度**ⓐ**时向左侧滑动。打开LED灯, 将刀片的影子投射到工件上, 并将刀片影子的左侧或右侧对准工件上的墨线。



图21

- (2) 打开开关后, 检查锯条是否以最大速度旋转, 慢慢地将手柄推下, 并将锯条放到要切割的材料附近。
- (3) 锯条接触工件后, 逐渐压下手柄, 以切入工件。
- (4) 切入工件至所需的深度后, 关闭电动工具, 让锯条完全停止, 再从工件中提起手柄, 使其回到完全收回位置。

警告！

- 不使用工具时，确认开关已关闭，且电源插头从插座中拔出。
- 在从工件中提起手柄前，务必关闭电源并让锯条完全停止。如在锯条仍旋转时提起手柄，则切除的碎片可能卡住锯条，使碎片飞散，造成危险。
- 每次完成深切割操作后，关闭开关，检查锯条是否停止。然后提起手柄，并使其回到完全收回位置。
- 务必从回转台上清除切割材料，然后进行下一步。
- 连续切割作业可能造成电动机过载。触摸电动机，若其较热，则立即停止切割作业并等候约10分钟，然后重新开始切割作业。

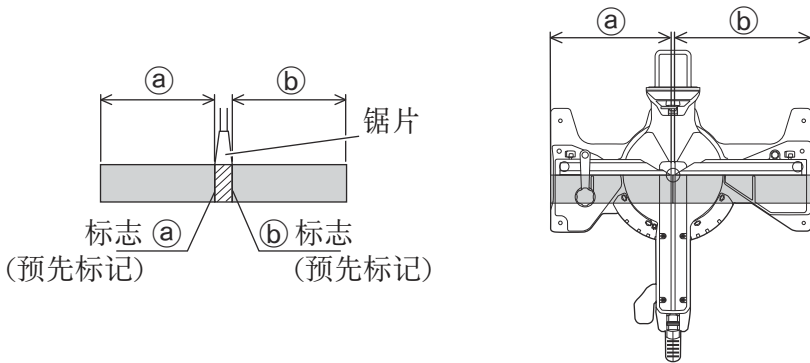
注意！

- 关于切割的最大尺寸，参见“规格”表。
- 在手柄上加大压力并不能提高切割速度。相反，压力过大可能使电动机过载与/或降低切割效率。

5. 切割窄工件（按压切割）（图22）

将回转支架向下滑动至支架（A），然后旋紧滑动固定旋钮。降低手柄来切割工件。以该方式使用电动工件允许切割最大107mm的工件。



图22

6. 切割大工件（图23, 图24）

根据工件高度的不同，可能会出现无法进行完整切割的情况。此时，借助挡板面上的7mm孔（每侧各有两个孔），使用6mm平头螺丝和6mm螺母安装辅助板。（图23）关于辅助板厚度，参见“规格”。

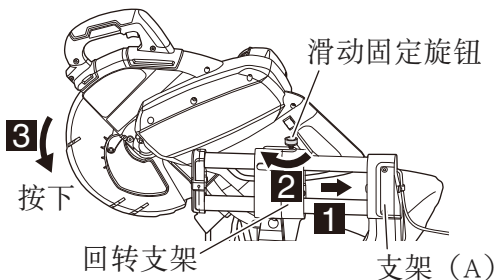

图23

注:

直角切割工件的高度超过107mm，左斜角切割工件的高度超过70mm或者右斜角切割工件的高度超过45mm时，请按照电动头底座不会与工件接触的原则调节下限位置。

如需调节锯条的下限位置，请遵照图24 所示的第（1）步。

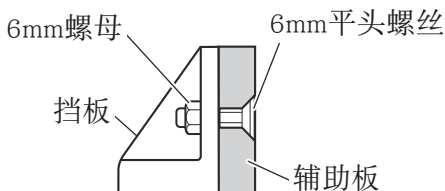
- (1) 降低电动头，然后转动6mm深度调节螺栓，并按照电动头下限位置和位于锯片下限位置（6mm深度调节螺栓头碰到回转支架的位置）时工件顶部之间的间隙为2mm至3mm的原则进行调节。



图24

7. 切割宽工件（滑动切割）（图25）

- (1) 最高107mm且最宽312mm的工件:

松开滑动固定旋钮 (A) (第11页的图3)，抓住手柄并向前滑动锯条。按压手柄并向前滑动锯条来切割工件。这样即可易于切割最高107mm且最宽312mm的工件。

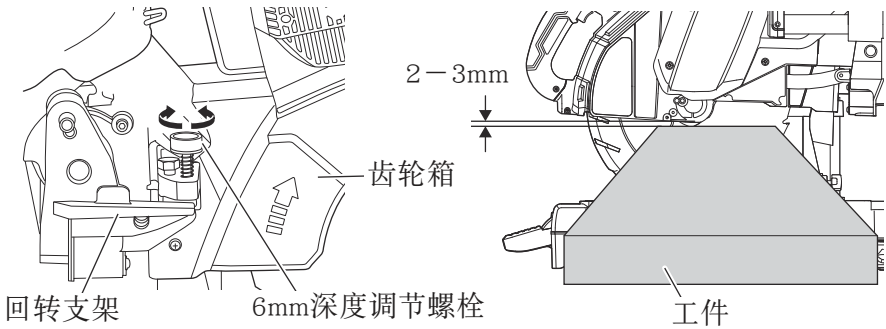

图25

- (2) 最高120mm且最宽260mm的工件：按照以上第7-（1）段所述的相同方式，可以切割最高120mm 且最宽260mm的工件。

警告！

- 关于滑动切割，请遵照以上所述步骤。由于锯条可能从工件中跳出，向前滑动切割（面向操作员）是非常危险的。因此，操作员请务必向外滑动手柄。
- 为了减少受伤的危险，每次横切作业之后，请务必将车架返回至最后端位置。
- 由于电动头降低时锯片会靠近斜接锁定手柄，因此切割作业期间切勿将您的手放在斜接锁定手柄上。

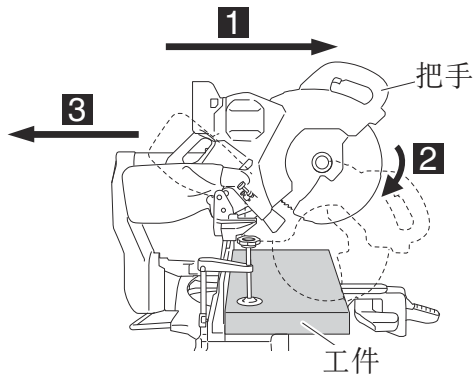
注意！

- 切割高度为120mm的工件时，按照处于下限位置时电动头下边缘和工件之间的间隙为2至3mm的原则调节电动头的下限位置。
- 如果用力或者横向按压手柄，则锯条在切割作业时可能会震动，并在工件上留下不必要的切割标记，导致切割品质降低。因此，请轻轻地且缓慢地按压手柄。
- 在滑动切割时，以单一、平滑的操作轻轻地向后推手柄。切割期间停止手柄移动会在工件上留下不必要的切割标记。

8. 斜角切割步骤

警告！

改变倾斜角度时，请压低电动头。如果电动头突然移动到某个倾斜的角度，可能会导致人员受伤或主体损坏。

- (1) 松开斜角锁定手柄，并向左或向右倾斜锯片。要向右改变斜角，请松开斜角锁定手柄，然后向前拉出固定销（A），并向右倾斜电动头。当电动头直立时，固定销（A）被紧固到位，因此在向右倾斜电动头之前，拔出固定销（A）时，将电动头稍微向左倾斜。
- (2) 在观察斜角尺和指针的同时，将斜角调整到所需的设定，然后固定斜角锁定手柄。

注意！

务必检查斜接锁定手柄是否牢固，电动头是否夹紧。如果您尝试在不夹紧电动头的情况下进行角度切割，则电动头可能会意外移动，导致人员受伤。

- (3) 遵循以上第5、6和7段所述程序。有关斜角切割的最大尺寸，请参阅第12页“表1：最大锯切尺寸”。

注:

斜角锁定手柄采用离合系统。接触斜角锁定手柄和主体时，请按照图26所示的箭头标记方向拉动斜角锁定手柄并改变其方向。



图26

警告！

- 工件固定于锯条左侧或右侧时，短小的切除部分会相应停留在锯条右侧或左侧。在从工件中提起手柄前，务必关闭电源并让锯条完全停止。如在锯条仍旋转时提起手柄，则切除的碎片可能卡住锯条，使碎片飞散，造成危险。
- 中途停止斜角切割作业时，应将电动头拉回初始位置，再开始切割。如未拉回而从中途开始切割，则可能造成下护罩卡在工件的切割凹槽中，并接触到锯片。
- 右角度进行切割时，拧松6mm翼栓，然后向外滑动副挡板（A）并取下。
- 左角度进行切割时，拧松6mm翼栓，然后向外滑动副挡板（B）。

注意！

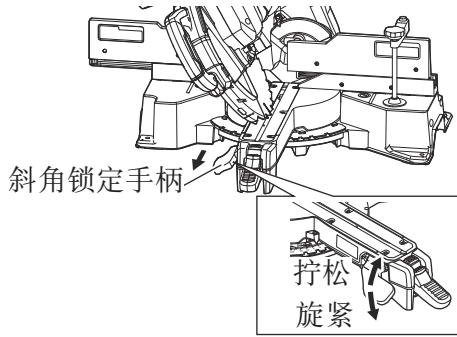
当在左45°斜角切割位置切割高度为75mm的工件或在右45°斜角切割位置切割高度为50mm的工件时，按照处于下限位置时电动头下边缘和工件之间的间隙为2至3mm的原则调整电动头的下限位置（请参见第18页的“11. 检查锯条的下限位置”）。

9. 斜接切割程序 (图27)

- (1) 提起斜接锁定手柄，解锁斜接工作台。
- (2) 轻轻按下前挡杆，直至其与棘爪杆啮合，同时握住斜接锁定手柄，将工作台向左或向右旋转到所需的角度的。
- (3) 达到所需的斜接角度后，按下斜接锁定手柄，将工作台固定到位。

- (4) 如果所需的斜接角度是如下所述的九个前挡块之一，请参见第23页的图16中的斜接棘爪杆部分。
- (5) 打开LED灯，将工件放置在工作台上，进行切割预对准。

注意！

务必检查斜接锁定手柄是否牢固，回转台是否夹紧。

如果试图在没有夹紧回转台的情况下进行角度切割，则回转台可能会意外移动，从而造成人员受伤。

注:

- 在 0° 中心设定的右侧与左侧， 15° 、 22.5° 、 31.6° 和 45° 设定的位置提供了前挡块。检查斜接尺与指针的尖端是否正确对齐。
- 在斜接尺与指针未对齐的情况下操作斜口锯，会造成切割精度下降。



图27

10. 复合切割步骤

您可以按照以上第8和第9步的说明进行复合切割。关于复合切割的最大尺寸，参见“规格”表。

注意！

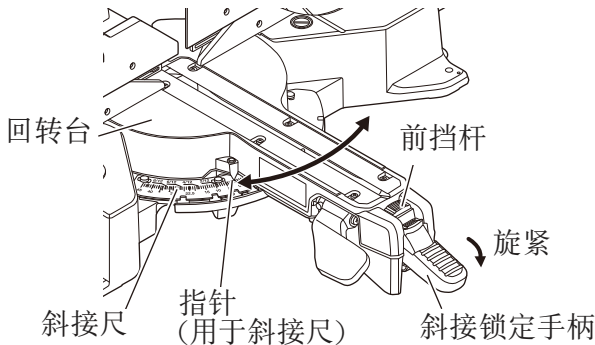
始终用右手或左手固定工件，用另一只手向后滑动斜口锯的圆形部分进行切割。

在复合切割过程中，左/右旋转回转台极为危险，因为锯片可能会接触到固定工件的手。

左斜角进行复合切割（角度 + 斜角）时，在切割操作前完全展开副挡板（B）。

右斜角进行复合切割（角度 + 斜角）时，向外滑动副挡板（A）并取下。

中文

11. 切割长材料

切割长材料时，使用与支架（选购件）相同高度的辅助台，以及专用辅助设备的底座。

容量：木材（W × H × L）

300mm × 45mm × 1300mm 或

180mm × 25mm × 2000mm

12. 安装支架...（选购件）

在切割操作中，支架可用于延长工件台并使之保持正确位置。

(1) 如图28所示，使用方钢来对齐支架的上缘与底座面。

松开6mm翼状螺母。旋转高度调节螺栓6mm，并调节支架的高度。



图28

- (2) 调节后，旋紧6mm翼状螺母并用6mm旋鈕螺栓（选购件）固定支架。如高度调节螺栓6mm的长度不足，则在其下方放置一块薄板。高度调节螺栓6mm的末端不得从支架中突出。

注意！

搬运此电动工具时，请勿抓住其支架。

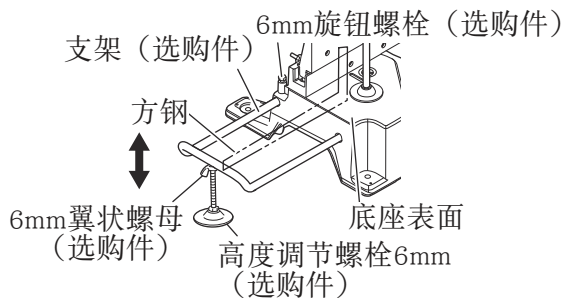
抓住支架有可能使底座滑出导致发生危险。

关于握持工具的正确方法，请参见第38页上的“主体的运输”。

13. 精密切割的止动片（止动片与支架为选购件）止动片有助于长度为285mm至450mm的连续精密切割。
安装止动片时，按照图29所示，用6mm旋钮螺栓将其与支架连接。



图29

14. 确认使用冠状模塑虎钳组件、冠状模塑止动片（L）和（R）（选购件）
- (1) 冠状模塑止动片（L）和（R）（选购件），可以方便地切割冠状模塑，而无需倾斜锯条。将其安装在底座两侧，如图30所示。插入后旋紧6mm旋钮螺栓，以固定冠状模塑止动片。
 - (2) 冠状模塑虎钳（B）（选购件）可安装在左挡板（挡板（B））或右挡板（挡板（A））上。它可与冠状模塑的斜角结合，并可按下虎钳。

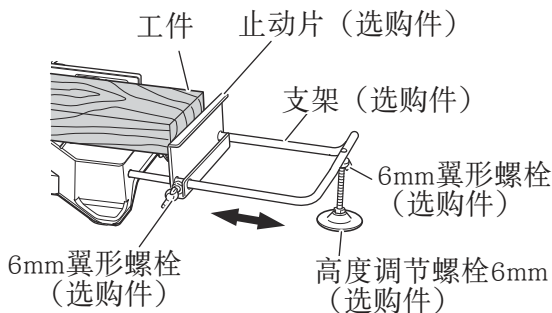

图30

然后按照需要转动上部旋钮，以可靠地连接冠状模塑。如需升高或降低虎钳组件，首先应松开六角套筒固定螺丝。调节高度后，旋紧6mm翼栓，然后按照需要旋转上部旋钮，以可靠地连接冠状模塑（图31）。
放置冠状模塑时，使其壁接触缘贴紧导引挡板，而其顶接触缘贴紧冠状模塑止动片，如图31所示。根据冠状模塑的大小来调节冠状模塑止动片。

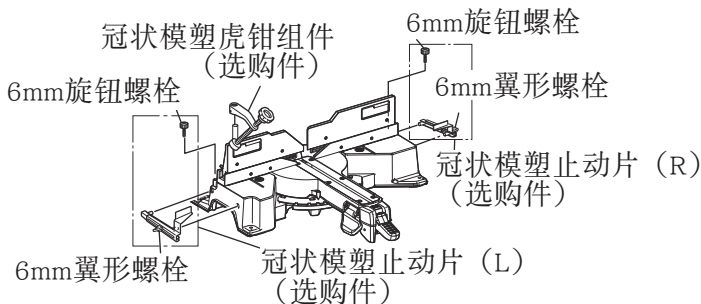

图31

旋紧6mm翼形螺栓以固定冠状模塑止动片。关于斜接角度，请参考下表。使用副挡板（A）确保冠状模塑更稳固（第26页的图20）。

警告！

务必夹紧或用虎钳将冠状模塑固定在挡板上，否则冠状模塑可能从台上冲出，而造成人身伤害。

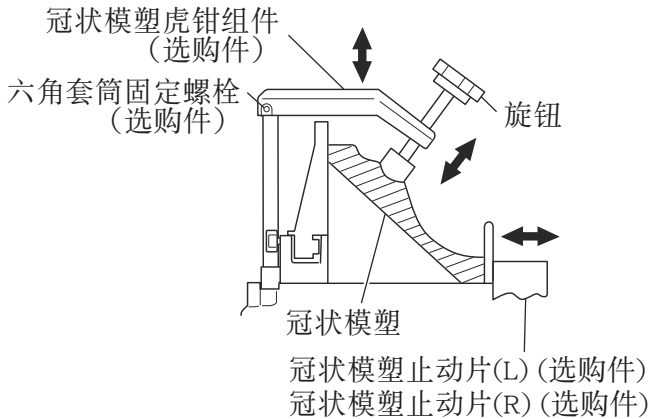
不要进行斜角切割。主体或锯条可能与副挡板接触，从而引起伤害。

注意！

务必确认电动头在降低进行切割时不会接触冠状模塑虎钳组件。如有发生接触的危险，则松开旋钮螺栓，并移动冠状模塑虎钳组件至不会接触锯条的位置。

15. 凹槽切割步骤

工件上的凹槽可通过调整6mm深度调节螺栓刻出（图32）。

- (1) 降低电动头，然后用手转动6mm深度调节螺栓。（6mm深度调节螺栓头接触回转支架。）

- (2) 通过设定锯条与底座表面之间的距离调节至想要的刻入深度（图32）。



图32

注:

在工件两端各刻出一条凹槽时，请用凿子凿去不需要的部分。

16. 连接除尘器（另售）（图33）

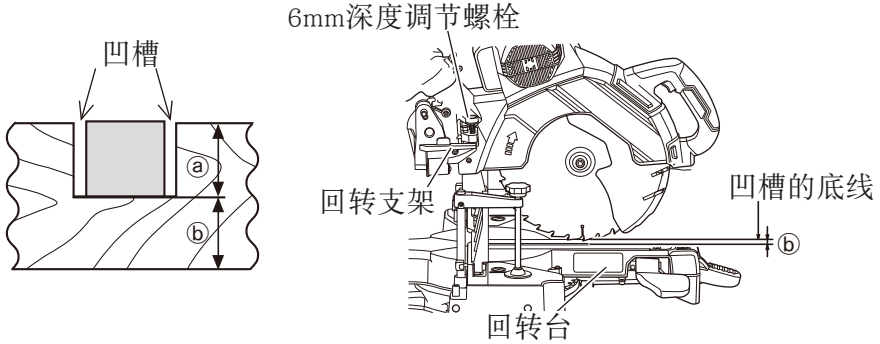
请勿吸入切割作业中产生的有害粉尘。

粉尘会危害自己的他人的身体健康。

使用除尘器可减少粉尘危害。

将适配器、接头和除尘适配器与除尘器连接，可清除大部分粉尘。

用适配器连接除尘器。

- (1) 按顺序将软管（内径38mm × 3m长）和适配器*2、接头（C）*1以及除尘适配器*1与电动工具的管道相连接。

按箭头方向进行连接。（图33）

使用管夹*1将除尘适配器*1固定到管道上。

*1 选购件

*2 除尘器的标准附件



图33

安装和拆卸锯条

警告！

为防止事故或人身伤害，在拆下或安装锯片之前，请务必关闭扳机开关并从电源插座上拔下电源插头。

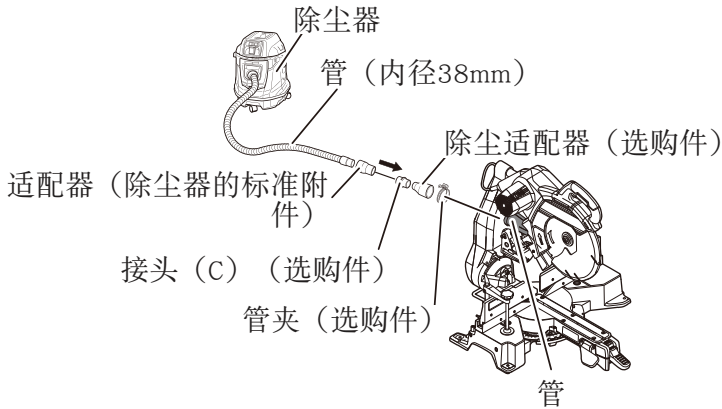
1. 安装锯片 (图34-a, 图34-b)

- (1) 按下主轴锁并用8mm扳手（标准附件）松开10mm螺栓。
由于10mm螺栓为左侧螺纹，需向右旋转将其松开。

注:

- 如难以按下主轴锁以锁定主轴，则在于主轴锁上施加压力的同时用8mm扳手（标准附件）转动10mm螺栓。
- 向内按下主轴锁时，锯条主轴被锁定。

(2) 取下螺栓与垫圈 (B)。



图34-a



图34-b

(3) 提起下护罩并安装锯条。

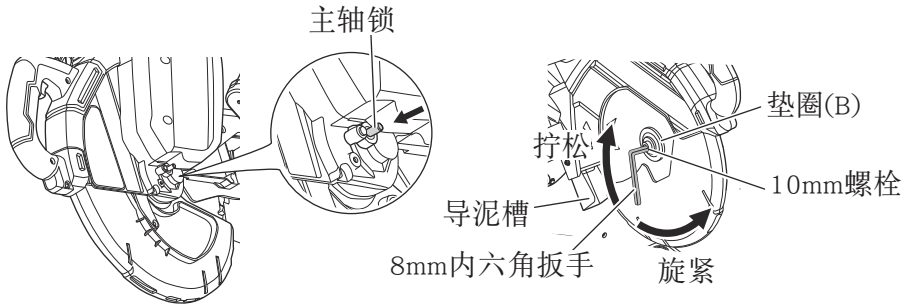
警告！

安装锯片时，确认锯片上的旋转指针标记和齿轮箱的旋转方向（第10页的图2）适配。

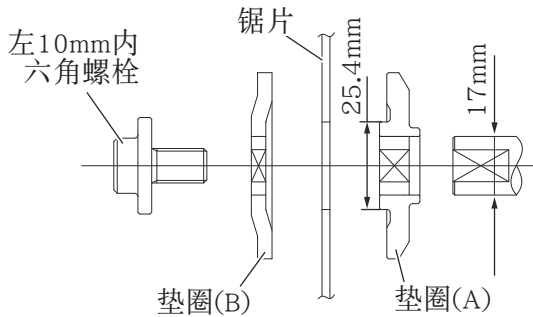
(4) 仔细清洗垫圈 (B) 与10mm螺栓，并将其安装在锯片主轴上。

(5) 压入主轴锁，通过8mm内六角扳手（标准附件）将10mm螺栓向左旋转并拧紧。

警告！

拧紧10mm螺栓，使其在操作过程中不会松动。启动电动工具前，确认10mm螺栓已正确拧紧。

注意！

- 在回转支架后部内侧安装有导泥槽。在安装或拆卸锯条时，请勿接触导泥槽。否则可能使锯条折断或碎裂。（图34-a）
 - 安装或拆下锯片后，确认主轴锁已回到收回位置。
2. 拆下锯片
通过反向操作安装程序来拆下锯片。
提起下护罩后可方便地拆下锯条。

注意！

切勿试图安装直径大于305mm的锯条。

主体的运输

警告！

为避免发生事故或人身伤害，在运输主体之前，请务必确认已关闭扳机开关且已从电源插座上拔下电源插头。

虎钳组件可能会在运输过程中掉落。通过拆下组件或在虎钳中间塞入一块木头，将其牢牢固定。（图35-b）

降低头部，插入锁定插销（参见第15页的“7. 松开锁定插销”）。同时拧入滑动固定旋钮，以便回转支架能够碰到支架（A）并固定头部。（图35-a）

提起斜接锁定手柄，尽可能向右转动回转台，并通过将斜接锁定手柄向下压至固定位置来固定回转台。主体会变得更小巧紧凑。（图35-b）



图35

运输主体时，用双手握住底座上的握把，抱在臂弯里。

双人搬运时，每个人都应用双手握住提手、手柄和底座握把。

维护和检查

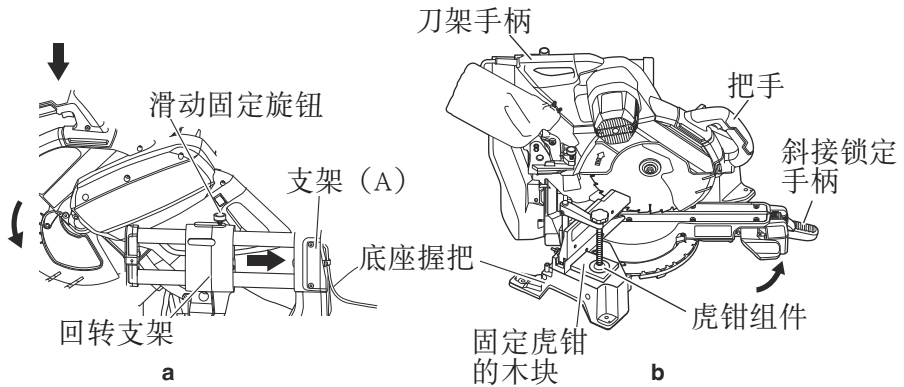
警告！

为避免发生事故或人身伤害，在对本电动工具进行任何维护或检查之前，请务必确认已关闭扳机开关且已从电源插座上拔下电源插头。

如果您发现护罩或锯条等发生机器故障，请及时告知有资格的维修人员进行维修。

1. 检查锯片

发现变质或损坏后应立即更换锯片。

损坏的锯片可引起人身伤害，而磨损的锯片则可导致无效的操作，并可能使电动机过载。

注意！

切勿使用不锋利的锯片。锯片不锋利时，它对于由工具手柄所施加的手部压力的阻力会增加，使电动工具的使用变得不安全。

2. 检查安装的螺丝

定期检查所有安装的螺丝，确保螺丝已完全拧紧。如果螺丝松动，请立即重新拧紧。否则可能导致严重的危险。

3. 检查炭刷（图36）

电动机采用的炭刷为消耗性部件。由于过度磨损的炭刷会导致电动机发生故障，当炭刷已严重磨损或接近“磨损极限”时，请更换如图所示相同型号的新炭刷。此外，经常保持炭刷清洁，确保炭刷在刷架内可顺畅滑动。

4. 更换炭刷（图36）

使用一字槽螺丝刀拆下炭刷帽。然后便可轻松取下炭刷。



图36

5. 电动机的维护

电动机绕组是电动工具的“核心”。应注意切勿使其暴露于油或水中而令绕线受损和/或受潮。

6. 检查下护罩是否操作无误

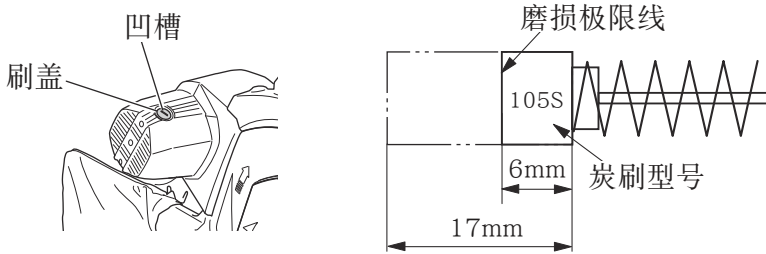
在每次使用工具之前，测试下护罩（第17页的图8）以确保其状态良好且运动自如。

除非下护罩操作正常、且机械状态良好，否则切勿使用工具。

7. 润滑

每月应润滑以下滑动面一次，以使电动工具长时间保持良好的工作状态。请使用推荐的机油。

注油位置：

- * 回转支架的转动部分
- * 支架 (A) 的转动部分
- * 虎钳组件的转动部分

8. 清洁

用气枪或其他工具吹出干燥空气，清洁机器、管道和下护罩。（图37）定期用蘸有肥皂水的湿布除去电动工具表面上的碎屑以及其他废料。为了避免电动机发生故障，切勿使其接触油或水。

如由于碎屑等粘在LED发光部分的窗口上而无法看清LED线，则用干布或以肥皂水等蘸湿的软布擦拭并清洁窗口。



图37

9. 储藏

工具使用后，应进行下列各项的检查：

- (1) 开关处于关闭（OFF）位置。
- (2) 电源插座从插座中拔出。

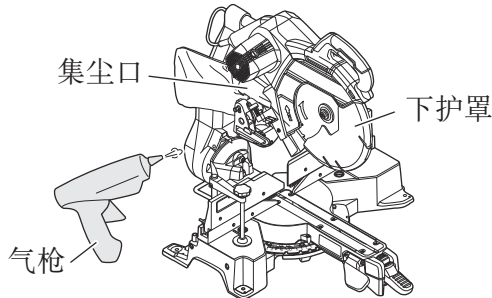
不使用工具时，将其储藏在儿童无法接触的干燥场所。

故障排除

如果工具操作不正常，请使用下表中的检查步骤。如果未能解决问题，请向经销商或HiKOKI公司授权服务中心咨询。

现象	可能的原因	解决办法
工具突然停止	工具过度负重	避免因负载过重而引发的问题。
	电机已自动停止以防止工具发生故障。	这种情况不属于故障。按下扳机开关5分钟或更久。再次打开电源。
请勿倾斜	未松开斜角锁定手柄。	松开斜角锁定手柄，然后倾斜工具。调节松动的元件后，确保再次拧紧。

中文

现象	可能的原因	解决办法
请勿向右倾斜	未拔出固定销（A）。	拔出固定销（A）后，向右倾斜。
	未松开斜角锁定手柄。	松开斜角锁定手柄，然后倾斜。
锯片变钝	锯片磨损或缺齿。	更换新锯片。
	螺栓松动。	拧紧螺栓。
	锯片装反。	按正确的方向安装锯片。
无法精确切割	工具的操作部件未完全固定。	完全安装斜角锁定手柄和斜接锁定手柄。
	材料无法固定到位。	清除挡板或回转台上的任何异物。
		在某些情况下，由于材料弯曲，无法固定到位。试着用挡板或回转台固定一个平面。

选择附件

根据特定作业选择适合的附件。
有关详细信息请联系HiKOKI授权服务中心。

产品编号:
328326

产品编号:
324452

产品编号:
339652

产品编号:
380840

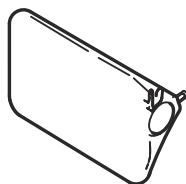
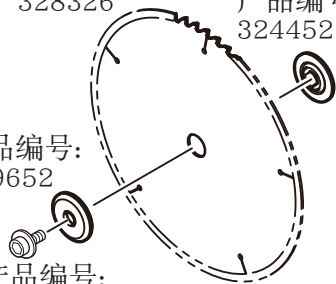

产品编号:
322955

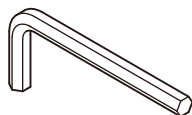

产品编号:
955857

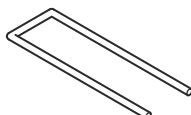

产品编号:
376730

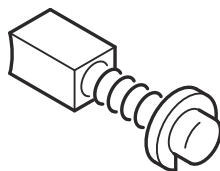

产品编号:
220V: 383529

产品编号:
960017

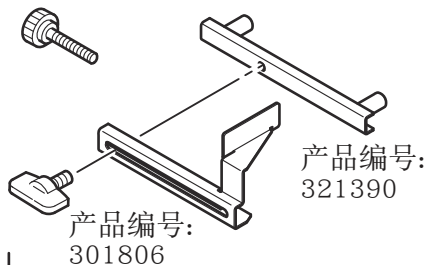

产品编号:
301806

产品编号:
321390

产品编号: 339730

产品编号:
960017

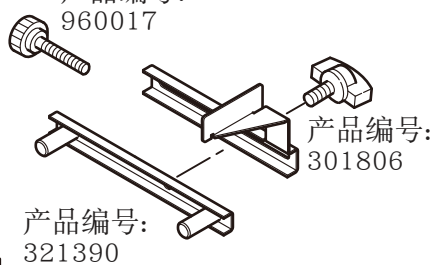

产品编号:
301806

产品编号:
321390

产品编号: 339731

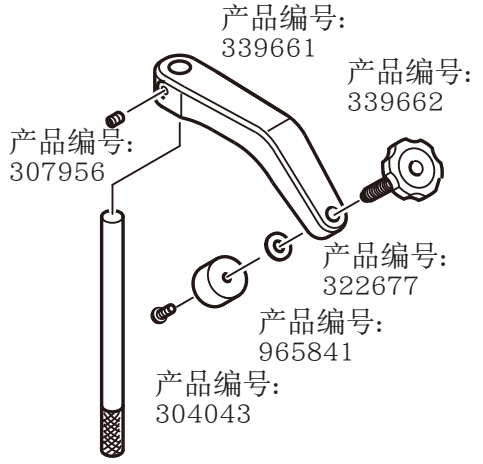
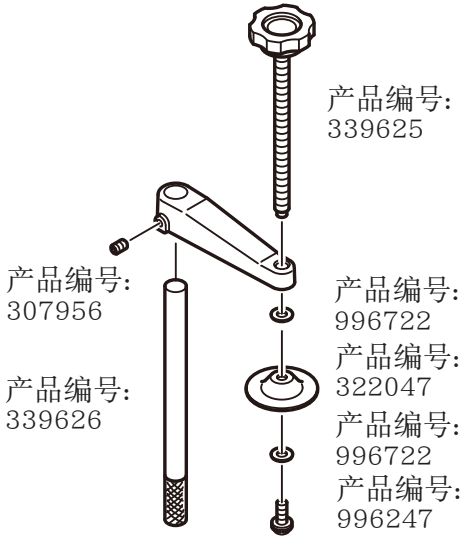

产品编号: 339624

产品编号: 339660

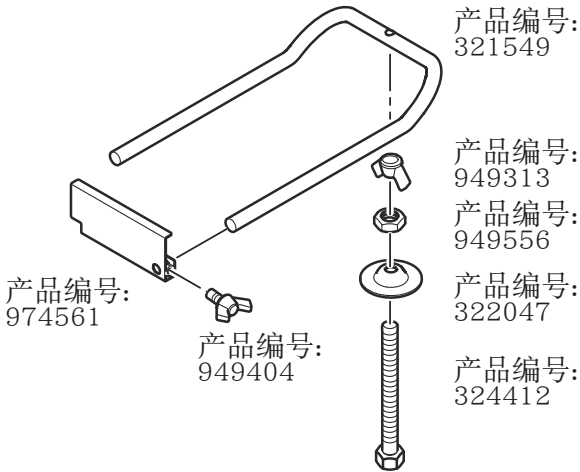

产品编号: 324464

CONTENTS

GENERAL POWER TOOL SAFETY WARNINGS.....	45
SAFETY INSTRUCTIONS FOR MITER SAW.....	47
PRECAUTIONS ON USING SLIDE COMPOUND MITER SAW.....	49
SYMBOLS.....	52
NAME OF PARTS.....	53
SPECIFICATIONS.....	54
STANDARD ACCESSORIES.....	56
APPLICATIONS.....	56
PRIOR TO OPERATION.....	56
PRIOR TO CUTTING.....	61
PRACTICAL APPLICATIONS.....	68
MOUNTING AND DISMOUNTING SAW BLADE.....	81
TRANSPORTATION OF THE MAIN BODY.....	83
MAINTENANCE AND INSPECTION.....	84
TROUBLESHOOTING.....	86
SELECTING ACCESSORIES.....	88

GENERAL POWER TOOL SAFETY WARNINGS

WARNING

Read all safety warnings, instructions, illustrations and specifications provided with this power tool.

Failure to follow all instructions listed below may result in electric shock, fire and/or serious injury.

Save all warnings and instructions for future reference.

The term “power tool” in the warnings refers to your mains-operated (corded) power tool or battery-operated (cordless) power tool.

- 1) **Work area safety**
 - a) **Keep work area clean and well lit.**
Cluttered or dark areas invite accidents.
 - b) **Do not operate power tools in explosive atmospheres, such as in the presence of flammable liquids, gases or dust.**
Power tools create sparks which may ignite the dust or fumes.
 - c) **Keep children and bystanders away while operating a power tool.**
Distractions can cause you to lose control.
- 2) **Electrical safety**
 - a) **Power tool plugs must match the outlet. Never modify the plug in any way. Do not use any adapter plugs with earthed (grounded) power tools.**
Unmodified plugs and matching outlets will reduce risk of electric shock.

English

- b) **Avoid body contact with earthed or grounded surfaces, such as pipes, radiators, ranges and refrigerators.**
There is an increased risk of electric shock if your body is earthed or grounded.
- c) **Do not expose power tools to rain or wet conditions.**
Water entering a power tool will increase the risk of electric shock.
- d) **Do not abuse the cord. Never use the cord for carrying, pulling or unplugging the power tool. Keep cord away from heat, oil, sharp edges or moving parts.**
Damaged or entangled cords increase the risk of electric shock.
- e) **When operating a power tool outdoors, use an extension cord suitable for outdoor use.**
Use of a cord suitable for outdoor use reduces the risk of electric shock.
- f) **If operating a power tool in a damp location is unavoidable, use a residual current device (RCD) protected supply.**
Use of an RCD reduces the risk of electric shock.

3) Personal safety

- a) **Stay alert, watch what you are doing and use common sense when operating a power tool. Do not use a power tool while you are tired or under the influence of drugs, alcohol or medication.**
A moment of inattention while operating power tools may result in serious personal injury.
- b) **Use personal protective equipment. Always wear eye protection.**
Protective equipment such as a dust mask, non-skid safety shoes, hard hat or hearing protection used for appropriate conditions will reduce personal injuries.
- c) **Prevent unintentional starting. Ensure the switch is in the off-position before connecting to power source and/or battery pack, picking up or carrying the tool.**
Carrying power tools with your finger on the switch or energising power tools that have the switch on invites accidents.
- d) **Remove any adjusting key or wrench before turning the power tool on.**
A wrench or a key left attached to a rotating part of the power tool may result in personal injury.
- e) **Do not overreach. Keep proper footing and balance at all times.**
This enables better control of the power tool in unexpected situations.
- f) **Dress properly. Do not wear loose clothing or jewellery. Keep your hair and clothing away from moving parts.**
Loose clothes, jewellery or long hair can be caught in moving parts.
- g) **If devices are provided for the connection of dust extraction and collection facilities, ensure these are connected and properly used.**
Use of dust collection can reduce dust-related hazards.
- h) **Do not let familiarity gained from frequent use of tools allow you to become complacent and ignore tool safety principles.**
A careless action can cause severe injury within a fraction of a second.

4) Power tool use and care

- a) **Do not force the power tool. Use the correct power tool for your application.**

The correct power tool will do the job better and safer at the rate for which it was designed.

- b) **Do not use the power tool if the switch does not turn it on and off.**
Any power tool that cannot be controlled with the switch is dangerous and must be repaired.
- c) **Disconnect the plug from the power source and/ or remove the battery pack, if detachable, from the power tool before making any adjustments, changing accessories, or storing power tools.**
Such preventive safety measures reduce the risk of starting the power tool accidentally.
- d) **Store idle power tools out of the reach of children and do not allow persons unfamiliar with the power tool or these instructions to operate the power tool.**
Power tools are dangerous in the hands of untrained users.
- e) **Maintain power tools and accessories. Check for misalignment or binding of moving parts, breakage of parts and any other condition that may affect the power tool's operation. If damaged, have the power tool repaired before use.**
Many accidents are caused by poorly maintained power tools.
- f) **Keep cutting tools sharp and clean.**
Properly maintained cutting tools with sharp cutting edges are less likely to bind and are easier to control.
- g) **Use the power tool, accessories and tool bits etc. in accordance with these instructions, taking into account the working conditions and the work to be performed.**
Use of the power tool for operations different from those intended could result in a hazardous situation.
- h) **Keep handles and grasping surfaces dry, clean and free from oil and grease.**
Slippery handles and grasping surfaces do not allow for safe handling and control of the tool in unexpected situations.

5) Service

- a) **Have your power tool serviced by a qualified repair person using only identical replacement parts.**
This will ensure that the safety of the power tool is maintained.

CAUTION

Keep children and infirm persons away.

When not in use, tools should be stored out of reach of children and infirm persons.

SAFETY INSTRUCTIONS FOR MITER SAW

1. **Miter saws are intended to cut wood or wood-like products, they cannot be used with abrasive cut-off wheels for cutting ferrous material such as bars, rods, studs, etc.**
Abrasive dust causes moving parts such as the lower guard to jam. Sparks from abrasive cutting will burn the lower guard, the kerf insert and other plastic parts.

English

- 2. Use clamps to support the workpiece whenever possible. If supporting the workpiece by hand, you must always keep your hand at least 100 mm from either side of the saw blade. Do not use this saw to cut pieces that are too small to be securely clamped or held by hand.**
If your hand is placed too close to the saw blade, there is an increased risk of injury from blade contact.
- 3. The workpiece must be stationary and clamped or held against both the fence and the table. Do not feed the workpiece into the blade or cut "freehand" in any way.**
Unrestrained or moving workpieces could be thrown at high speeds, causing injury.
- 4. Push the saw through the workpiece. Do not pull the saw through the workpiece. To make a cut, raise the saw head and pull it out over the workpiece without cutting, start the motor, press the saw head down and push the saw through the workpiece.**
Cutting on the pull stroke is likely to cause the saw blade to climb on top of the workpiece and violently throw the blade assembly towards the operator.
- 5. Never cross your hand over the intended line of cutting either in front or behind the saw blade.**
Supporting the workpiece "cross handed" i.e. holding the workpiece to the right of the saw blade with your left hand or vice versa is very dangerous.
- 6. Do not reach behind the fence with either hand closer than 100 mm from either side of the saw blade, to remove wood scraps, or for any other reason while the blade is spinning.**
The proximity of the spinning saw blade to your hand may not be obvious and you may be seriously injured.
- 7. Inspect your workpiece before cutting. If the workpiece is bowed or warped, clamp it with the outside bowed face toward the fence. Always make certain that there is no gap between the workpiece, fence and table along the line of the cut.**
Bent or warped workpieces can twist or shift and may cause binding on tile spinning saw blade while cutting. There should be no nails or foreign objects in the workpiece.
- 8. Do not use the saw until the table is clear of all tools, wood scraps, etc., except for the workpiece.**
Small debris or loose pieces of wood or other objects that contact the revolving blade can be thrown with high speed.
- 9. Cut only one workpiece at a time.**
Stacked multiple workpieces cannot be adequately clamped or braced and may bind on the blade or shift during cutting.
- 10. Ensure the miter saw is mounted or placed on a level, firm work surface before use.**
A level and firm work surface reduces the risk of the miter saw becoming unstable.
- 11. Plan your work. Every time you change the bevel or miter angle setting, make sure the adjustable fence is set correctly to support the workpiece and will not interfere with the blade or the guarding system.**
Without turning the tool "ON" and with no workpiece on the table, move the saw blade through a complete simulated cut to assure there will be no interference or danger of cutting the fence.

12. **Provide adequate support such as table extensions, saw horses, etc. for a workpiece that is wider or longer than the table top.**
Workpieces longer or wider than the miter saw table can tip if not securely supported. If the cut-off piece or workpiece tips, it can lift the lower guard or be thrown by the spinning blade.
13. **Do not use another person as a substitute for a table extension or as additional support.**
Unstable support for the workpiece can cause the blade to bind or the workpiece to shift during the cutting operation pulling you and the helper into the spinning blade.
14. **The cut-off piece must not be jammed or pressed by any means against the spinning saw blade.**
If confined, i.e. using length stops, the cut-off piece could get wedged against the blade and thrown violently.
15. **Always use a clamp or a fixture designed to properly support round material such as rods or tubing.**
Rods have a tendency to roll while being cut, causing the blade to "bite" and pull the work with your hand into the blade.
16. **Let the blade reach full speed before contacting the workpiece.**
This will reduce the risk of the workpiece being thrown.
17. **If the workpiece or blade becomes jammed, turn the miter saw off. Wait for all moving parts to stop and disconnect the plug from the power source and/or remove the battery pack. Then work to free the jammed material.**
Continued sawing with a jammed workpiece could cause loss of control or damage to the miter saw.
18. **After finishing the cut, release the switch, hold the saw head down and wait for the blade to stop before removing the cut-off piece.**
Reaching with your hand near the coasting blade is dangerous.
19. **Hold the handle firmly when making an incomplete cut or when releasing the switch before the saw head is completely in the down position.**
The braking action of the saw may cause the saw head to be suddenly pulled downward, causing a risk of injury.

PRECAUTIONS ON USING SLIDE COMPOUND MITER SAW

1. **Keep the floor area around the machine level. Well maintained and free of loose materials e.g. chips and cut-offs.**
2. **Provide adequate general or localized lighting.**
3. **Do not use power tools for applications other than those specified in the handling instructions.**
4. **Repairing must be done only by authorized service facility. Manufacturer is not responsible for any damages and injuries due to the repair by the unauthorized persons as well as the mishandling of the tool.**
5. **To ensure the designed operational integrity of power tools, do not remove installed covers or screws.**

English

6. Do not touch movable parts or accessories unless the power source has been disconnected.
7. Use your tool at lower input than specified on the nameplate; otherwise, the finish may be spoiled and working efficiency reduced due to motor overload.
8. Do not wipe plastic parts with solvent. Solvents such as gasoline, thinner, benzine, carbon tetrachloride, alcohol, may damage and crack plastic parts. Do not wipe them with such solvent. Clean plastic parts with a soft cloth lightly dampened with soapy water.
9. Use only original HiKOKI replacement parts.
10. This tool should only be disassembled for replacement of carbon brushes.
11. Never cut ferrous metals or masonry.
12. Adequate general or localized lighting is provided. Stock and finished workpieces are located close to the operators normal working position.
13. Wear suitable personal protective equipment when necessary, this could include:
Hearing protection to reduce the risk of induced hearing loss.
Eye protection to reduce the risk of injuring an eye.
Respiratory protection to reduce the risk of inhalation of harmful dust.
Gloves for handling saw blades (saw blades shall be carried in a holder wherever practicable) and rough material.
14. The operator is adequately trained in the use, adjustment and operation of the machine.
15. Refrain from removing any cut-offs or other parts of the workpiece from the cutting area whilst the machine is running and the saw head is not in the rest position.
16. Never use the slide compound miter saw with its lower guard locked in the open position.
17. Ensure that the lower guard moves smoothly.
18. Do not use the saw without guards in position, in good working order and properly maintained.
19. Use correctly sharpened saw blades. Observe the maximum speed marked on the saw blade.
20. Do not use saw blades which are damaged or deformed.
21. Do not use saw blades manufactured from high speed steel.
22. Use only saw blades recommended by HiKOKI.
23. The saw blades should be 305 mm external diameter ranges.
24. Select the correct saw blade for the material to be cut.
25. Never operate the slide compound miter saw with the saw blade turned upward or to the side.
26. Ensure that the workpiece is free of foreign matter such as nails.
27. Replace the table insert when worn.
28. Do not use the saw to cut other than aluminium, wood or similar materials.
29. Do not use the saw to cut other materials than those recommended by the manufacturer.
30. Blade replacement procedure, including the method for repositioning and a warning that this must be carried out correctly.

31. Connect the slide compound miter saw to a dust collecting device when sawing wood.
32. Take care when slotting.
33. When transporting or carrying the tool, do not grasp the holder. Grasp the handle instead of the holder.
34. Start cutting only after motor revolution reaches maximum speed.
35. Promptly cut OFF the switch when abnormality observed.
36. Shut off power and wait for saw blade to stop before servicing or adjusting tool.
37. During a miter or bevel cut the blade should not be lifted until it has stopped rotation completely.
38. During slide cutting operation, the saw must be pushed and slid away from the operator.
39. Take all the possibility of residual risks in cutting operation into your consideration, such as the inadvertent access to moving parts on slide mechanical parts on machine and so on.
40. Ensure before each cut that the machine is stable.
Use only saw blades whose maximum permitted speed is higher than the no-load speed of the power tool.
Do not replace the LED light with a different type.
41. Do not stand in a line with the saw blade in front of the machine. Always stand aside of the saw blade. This protects your body against possible kickback. Keep hands, fingers and arms away from the rotating saw blade.
Do not cross your arms when operating the tool arm.
42. If the saw blade should become jammed, switch the machine off and hold the workpiece until the saw blade comes to a complete stop. To prevent kickback, the workpiece may not be moved until after the machine has come to a complete stop. Correct the cause for the jamming of the saw blade before restarting the machine.
43. When the saw head is in the down position, never release the hand that is gripping the handle.
Doing so could snap the saw head up, forcing the tool to fall and possibly cause injury.
44. Make sure to securely hold the tool during operation. Failure to do so can result in accidents or injuries. (Fig. 1)

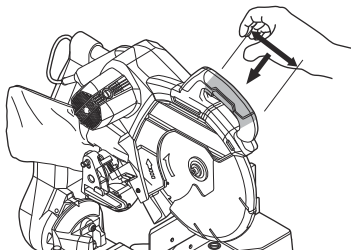







Fig. 1

SYMBOLS

WARNING

The following show symbols used for the machine. Be sure that you understand their meaning before use.

	To reduce the risk of injury, user must read instruction manual.
	Do not stare at operating lamp.
	Always wear eye protection.
	Always wear hearing protection.
V	Rated voltage
A	Current
W	Watt
n_0	No-load speed
/min	Revolutions per minute
	Class II tool
	Warning

NAME OF PARTS

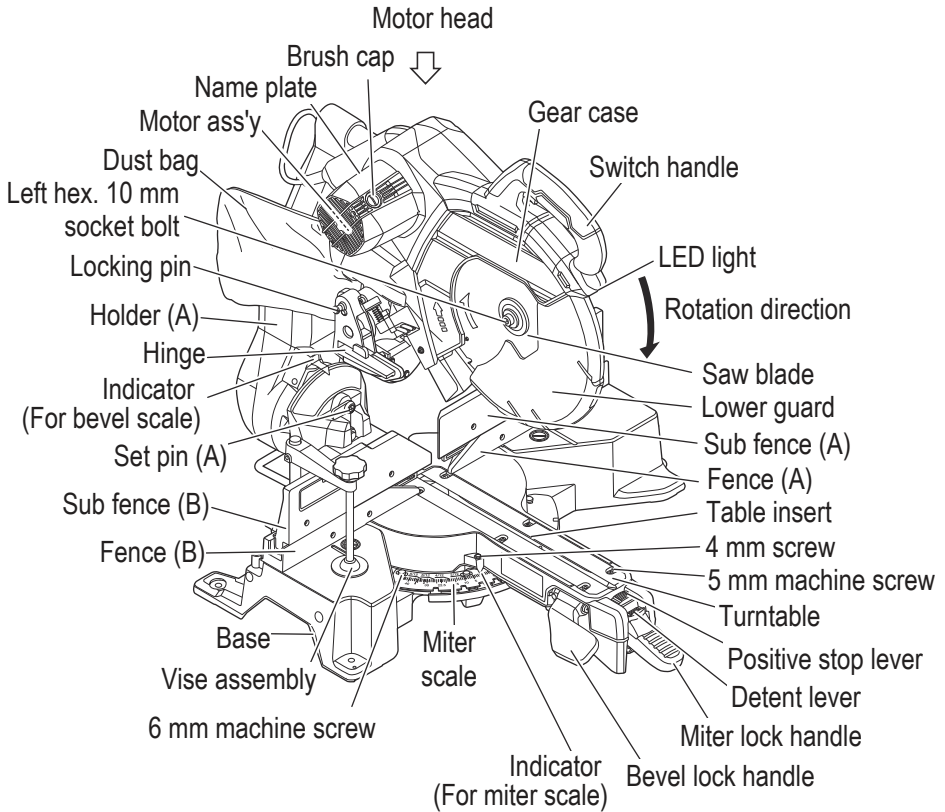

Fig. 2

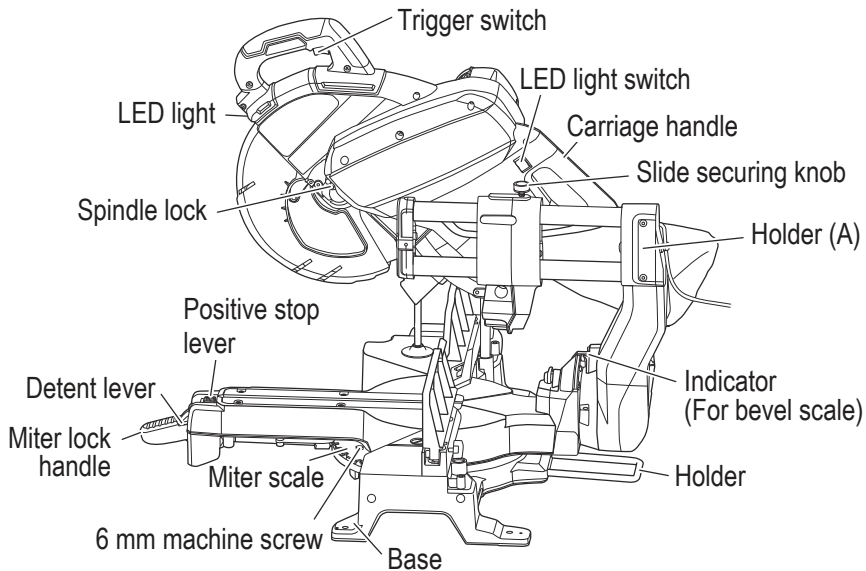

Fig. 3

SPECIFICATIONS

Model	C 12RSH3	
Motor	Type	Series commutator motor
	Voltage	220 V
	Power input	1520 W
LED light	Yes	
Applicable saw blade	Outside Dia. 305 mm, Hole Dia. 25.4 mm	
No load speed	4000 /min	
Miter sawing range	Left 0°–45° Right 0°–57°	
Bevel sawing range	Left 0°–45° Right 0°–45°	
Compound sawing range	Left (Bevel) 0°–45°	Left (Miter) 0°–45°, Right (Miter) 0°–45°
	Right (Bevel) 0°–45°	Right (Miter) 0°–45°, Left (Miter) 0°–45°
Net weight*1	24.3 kg	
Cord	2 Conductor type cable 1.8 m	

*1 Weight is without the saw blade.

Table 1 : Max. sawing dimension



	Head	Turntable	Max. sawing dimension		
			Max. height	Max. width	With aux. board
Miter	0	0	107 mm	312 mm	-
			*120 mm	260 mm	25 mm
		Left 45° or Right 45°	107 mm	220 mm	-
			*120 mm	180 mm	25 mm
		Right 57°	107 mm	170 mm	-
			*120 mm	130 mm	25 mm
Bevel	Left 45°	0	70 mm	312 mm	-
			*75 mm	260 mm	25 mm
	Right 45°	0	45 mm	312 mm	-
			*50 mm	260 mm	25 mm
Compound	Left 45°	Left 45°	70 mm	220 mm	-
			*75 mm	180 mm	25 mm
		Right 45°	70 mm	220 mm	-
			*75 mm	180 mm	25 mm
	Right 45°	Left 45°	45 mm	220 mm	-
			*50 mm	180 mm	25 mm
		Right 45°	45 mm	220 mm	-
			*50 mm	180 mm	25 mm

When cutting the workpiece which has the dimension of “*” there might be some possibility of the lower end of the circular saw to touch with the workpiece, even if the motor head is located at the lower limit position. Pay attention when cutting the workpiece. For further details, refer to “PRACTICAL APPLICATIONS” on page 68. Mount the auxiliary board on the fence surface Refer to “6. Cutting large workpieces” on page 72 (Fig. 23 on page 72).

STANDARD ACCESSORIES

In addition to the main unit (1 unit), the package contains the accessories listed in the below.

Table 2

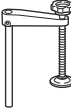
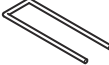
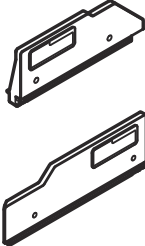
	305 mm TCT Saw blade (mounted on tool)	1
	Dust bag	1
	8 mm Hex. bar	1
	Vise Assembly	1
	Holder	1
	Sub Fence (mounted on tool)	1

APPLICATIONS

Cutting various types of aluminium sash and wood.

PRIOR TO OPERATION

WARNING

Make all necessary adjustments before inserting the plug in the power source.

1. Power source
Ensure that the power source to be utilized conforms to the power requirements specified on the product nameplate.

Do not use with direct current, or transformers such as boosters. Doing so may result in damage or accidents.

2. Power switch

Ensure that the power switch is in the OFF position. If the plug is connected to a receptacle while the trigger switch is in the ON position, the power tool will start operating immediately, inviting serious accident.

3. Extension cord

When the work area is removed from the power source, use an extension cord of sufficient thickness and rated capacity. The extension cord should be kept as short as practicable.

4. Remove all packing materials attached or connected to the tool before attempting to operate it.

5. Installation (**Fig. 4**)

Ensure that the machine is always fixed to bench. Attach the power tool to a level, horizontal work bench.

Select 8 mm diameter bolts suitable in length for the thickness of the work bench.

Bolt length should be at least 40 mm plus the thickness of the work bench.

For example, use 8 mm x 65 mm bolts for a 25 mm thick work bench.

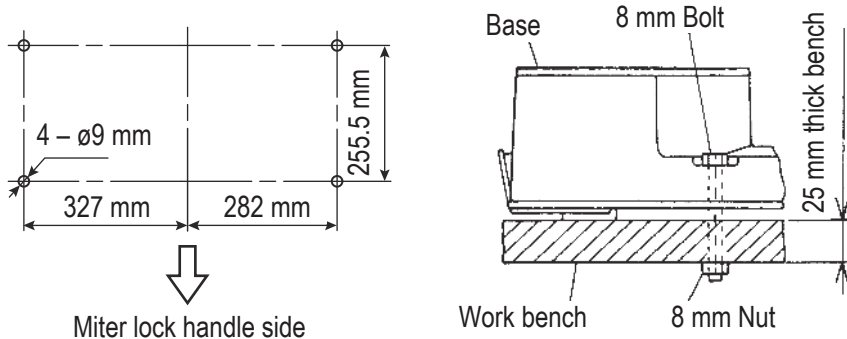

Fig. 4

English

6. Base holder adjustment (Fig. 5)

Loosen the 6 mm bolt with the 10 mm box wrench. Adjust the base holder until its bottom surface contacts the bench or the floor surface. After adjustment, firmly tighten the 6 mm bolt.

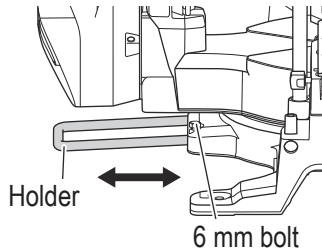

Fig. 5

7. Releasing the locking pin (Fig. 6)

When the power tool is prepared for shipping, its main parts are secured by a locking pin. Press the handle slightly down and pull out the locking pin to disengage the cutting head. During transport, lock the locking pin into the gear case.

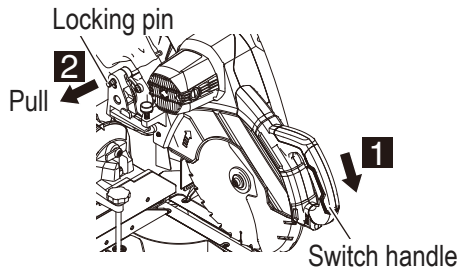

Fig. 6

8. Installing the dust bag, stopper and vises (The stopper is an optional accessory.)

(1) Installing the dust bag (Fig. 7)

Install the dust bag onto the dust port on the miter saw.

Fit the connecting tube of dust bag and the dust port together.

To empty the dust bag, pull out the dust bag assembly from dust port. Open zipper on underside of bag and empty into waste container. **Check frequently and empty the dust bag before it gets full.**

When bevel angle cutting, adjust the support bar and Install the dust bag so that it hangs down vertically.

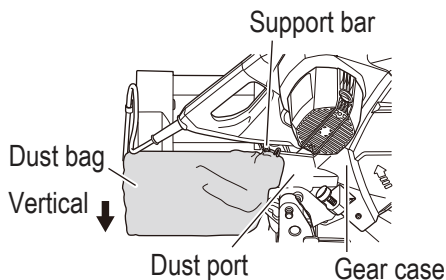

Fig. 7

WARNING

Do not use this saw to cut and/or sand metals. The hot chips or sparks may ignite saw dust from the bag material.

CAUTION

- Empty the dust bag frequently to prevent the duct and the lower guard from becoming clogged.
Sawdust will accumulate more quickly than normal during bevel cutting.
- After cutting wood, before starting to cut aluminum window sash, discard the chips that are in the dust bag.

(Attach the vise assembly as shown in **Fig. 20 on page 70** and also stopper as shown in **Fig. 29 on page 77.**)

9. Check the lower guard for proper operation

WARNING

NEVER OPERATE THE POWER TOOL if the lower guard does not function smoothly.

English

Lower guard is designed to protect the operator from coming into contact with the saw blade during operation of the tool.

Always check that the lower guard moves smoothly and covers the saw blade properly. (**Fig. 8**)

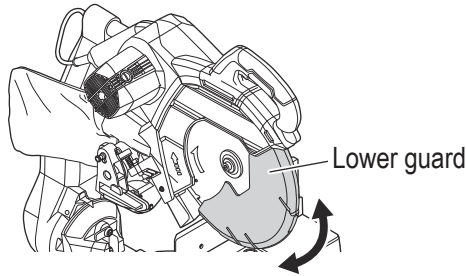

Fig. 8

10. Oblique angle

WARNING

When changing the oblique angle, hold down the motor head. If the motor head moves to an oblique angle suddenly, it may result in injury or damage to the main body.

Before the power tool is shipped from the factory, it is adjusted for 0°, right angle, left 45° bevel cutting angle and right 45° bevel cutting angle with the 8 mm set screws.

When changing the adjustment, change the height of the 8 mm set screws by turning them. (**Fig. 9-a, Fig. 9-b**)

When changing the bevel angle to the left 45°, loosen the 6 mm wing bolt shown in **Fig. 13 on page 64**, then slide the sub fence (B) outward and incline the motor head to the left. To change the bevel angle to the right at 45°, move the sub fence (A) outward and loosen the bevel lock handle, then pull out the set pin (A) toward the front, and tilt the motor head to the right. (**Fig. 9-b**)

When the motor head is straight upright, the set pin (A) is held tightly in place, so tilt the motor head slightly to the left when pulling out the set pin (A) before tilting the motor head to the right.

When adjusting the motor head to 0°, always return the set pin (A) to its initial position as shown in **Fig. 9-b**.

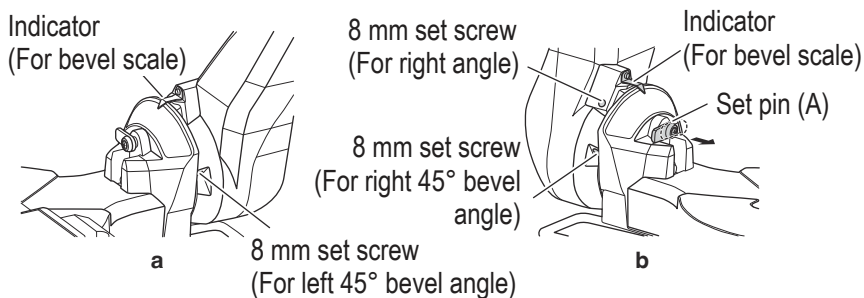

Fig. 9

11. Checking the saw blade lower limit position

Check that the saw blade can be lowered 9 mm to 11 mm below the table insert. When you replace a saw blade with a new one, adjust the lower limit position so that the saw blade will not cut the turntable or complete cutting cannot be done.

To adjust the lower limit position of the saw blade, follow the procedure (1) indicated below. (Fig. 10)

- (1) Turn the 8 mm depth adjustment bolt, change the height where the bolt head and the hinge contacts, and adjust the lower limit position of the saw blade.

NOTE

Confirm that the saw blade is adjusted so that it will not cut into the turntable.

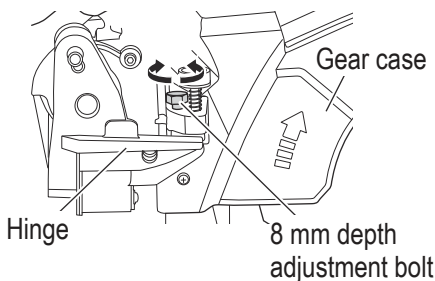

Fig. 10

PRIOR TO CUTTING

1. Positioning the table insert

Table inserts are installed on the turntable. When shipping the tool from the factory, the table inserts are so fixed that the saw blade does not contact them. The burr of the bottom surface of the workpiece is remarkably reduced, if the table insert is fixed so that the gap between the side surface of the table insert and the saw blade will be minimum. Before using the tool, eliminate this gap in accordance with the following procedure.

English

(1) Right angle cutting (**Fig. 11-a**)

Loosen the three 5 mm machine screws, then secure the left side table insert and temporarily tighten the 5 mm machine screws of both ends. Then fix a workpiece (about 200 mm wide) with the vise assembly and cut it off. After aligning the cutting surface with the edge of the table insert, securely tighten the 5 mm machine screws of both ends. Remove the workpiece and securely tighten the 5 mm center machine screw. Adjust the right hand table insert in the same way.

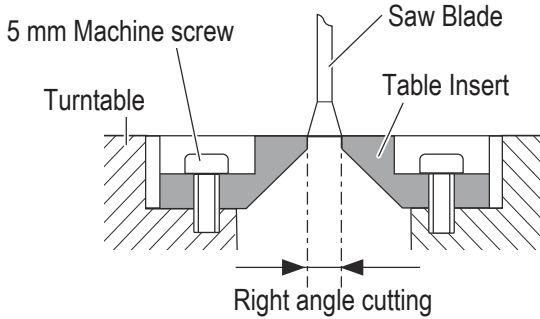

Fig. 11-a

(2) Left and right bevel angle cutting (**Fig. 11-b, Fig. 11-c**)

Adjust the table insert in the manner same procedure for right angle cutting.

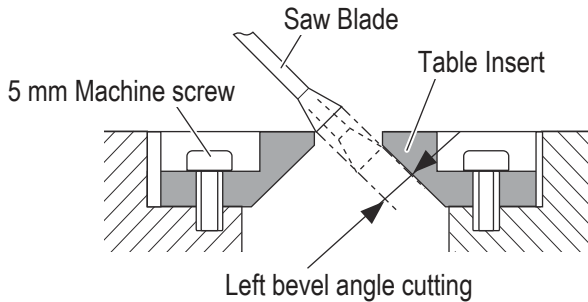

Fig. 11-b

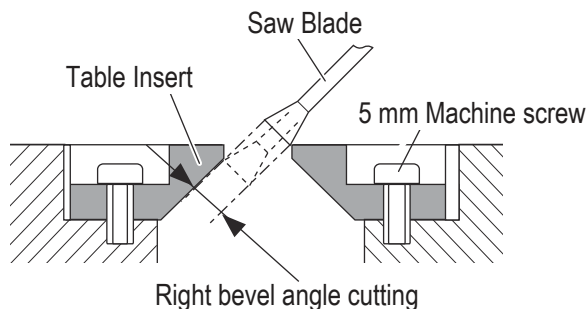

Fig. 11-c

CAUTION

After adjusting the table insert for right angle cutting, the table insert will be cut to some extent if it is used for bevel angle cutting.

When bevel cutting operation is required, adjust the table insert for bevel angle cutting.

2. Confirmation for use of sub fence (A) (Fig. 12)

WARNING

When right bevel angle cutting, loosen the 6 mm wing bolt, then slide the sub fence (A) outward and remove it. Failure to do so may result in the main body or saw blade coming into contact with the sub fence (A) and causing injury.

This power tool is equipped with a sub fence (A). In the case of direct angle cutting and left bevel angle cutting, use the sub fence (A). Then, you can realize stable cutting of the material with a wide back face.

CAUTION

In the case of direct angle cutting and left bevel angle cutting, slide inward to the position where the sub fence (A) hits, and secure it with 6 mm wing bolt. (as shown in Fig. 12)

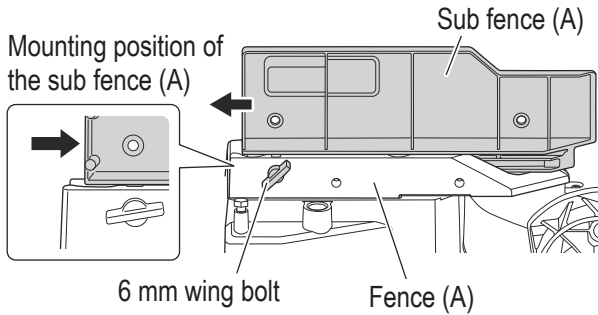

Fig. 12

3. Confirmation for use of sub fence (B) (Fig. 13)

WARNING

When left bevel angle cutting, loosen the 6 mm wing bolt, then slide the sub fence (B) outward. Failure to do so may result in the main body or saw blade coming into contact with the sub fence (B) and causing injury.

This power tool is equipped with a sub fence (B). In the case of direct angle cutting and right bevel angle cutting, use the sub fence (B). Then, you can realize stable cutting of the material with a wide back face.

CAUTION

In the case of direct angle cutting and right bevel angle cutting, slide inward to the position where the sub fence (B) hits, and secure it with 6 mm wing bolt. (as shown in Fig. 13)

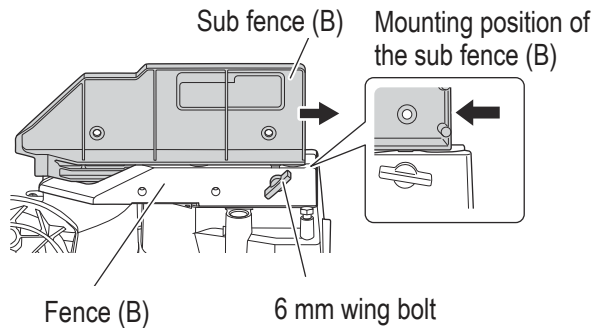

Fig. 13

4. Slide carriage system (Fig. 14)

WARNING

To reduce the risk of injury, return slide carriage to the full rear position after each crosscut operation.

For chop cutting operations on small workpieces, slide the cutting head assembly completely toward the rear of the unit and tighten the slide securing knob. To cut wide boards up to 312 mm, the slide securing knob must be loosened to allow the cutting head slide freely. (Fig. 14)

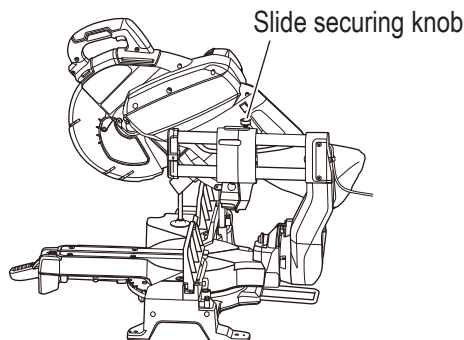

Fig. 14

5. Miter scale adjustment

- Down the head and insert the locking pin.

Unlock the miter lock handle and swing the turntable until the positive stop locks it at the 0° miter position.

Do not lock the miter lock handle. Place a square against the saw's fence and blade, as shown in Fig. 15. (Do not touch the tips of the blade teeth with the square. To do so will cause an inaccurate measurement.)

If the saw blade is not exactly perpendicular to the fence, loosen the 6 mm machine screws (4 pcs.) that hold the miter scale and move the miter lock handle and the scale left or right until the blade is perpendicular to the fence, as measured with the square.

Retighten the 6 mm machine screws (4 pcs.). (Fig. 15)

Pay no attention to the reading of the indicator (for miter scale) at this time.

- Indicator (for miter scale) adjustment

Unlock the miter lock handle to move the turntable to the 0° position. With the miter lock handle unlocked, allow the positive stop to snap into place as you rotate the turntable to 0°. Observe the indicator (for miter scale) and miter scale as shown in Fig. 15. If the indicator (for miter scale) does not indicate exactly 0° loosen the 4 mm screw holding the indicator (for miter scale). In place reposition the indicator (for miter scale) and tighten the 4 mm screw.

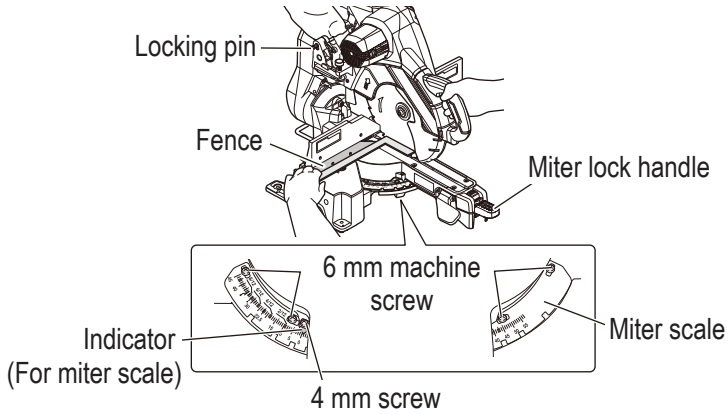

Fig. 15

6. Miter angle adjustment

The slide compound miter saw scale can be easily read, showing miter angles from 0° to 45° to the left and right. The miter saw table has nine of the most common angle settings with positive stops at 0°, 15°, 22.5°, 31.6°, and 45°. These positive stops position the blade at the desired angle quickly and accurately. Follow the process below for quickest and most accurate adjustments. (**Fig. 16**)

Adjusting miter angles:

- (1) Push up the miter lock handle to release the turntable.
- (2) Push down the positive stop lever until the detent lever catches on it to release the “positive stop”.
- (3) Rotate the turntable and set the indicator to line up with the desired angle of the miter scale. At this time, when using the positive stop function, pull the detent lever in the direction of the arrow near the desired angle as shown in **Fig. 16**, release the detent lever, and move the turntable to secure it in place at the desired angle via the positive stop function. (0°, 15°, 22.5°, 31.6°, and 45°)
- (4) Push down the miter lock handle to secure the turntable in place.

Detent lever (**Fig. 16**)

The detent lever allows for the table to be micro adjusted, disengaging the positive detent stops feature. When a required miter angle is close to a positive detent stop, this detent lever prevents the wedge on the positive stop lever from slipping into that detent slot on the base.

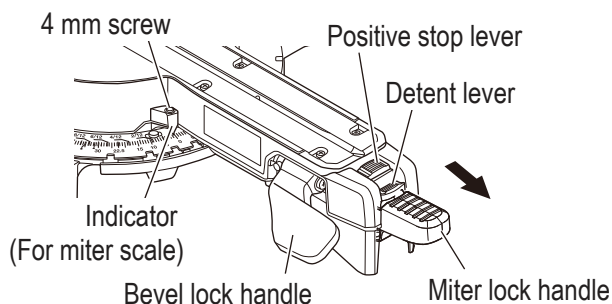

Fig. 16

7. LED lighting system (Fig. 17) [XACT CUT LED™]

CAUTION

Do not stare at operating lamp. Staring into the light beam may result in serious injury or vision loss.

The LED lighting system [XACT CUT LED™] casts the shadow of the blade onto the workpiece. This results in greater accuracy of cuts and requires no adjustments.

To use this feature, turn the LED light switch on.

Bring the motor head down so the blade is approximately 6 mm from the workpiece. The shadow of the blade will be projected onto the workpiece, indicating where the blade teeth will make contact as the cut is made.

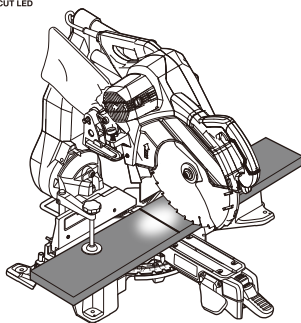

Fig. 17

PRACTICAL APPLICATIONS

WARNING

- To avoid personal injury, never remove or place a workpiece on the table while the tool is being operated.
- Never place your limbs inside of the line next to warning sign while the tool is being operated (see Fig. 18). This may cause hazardous conditions.

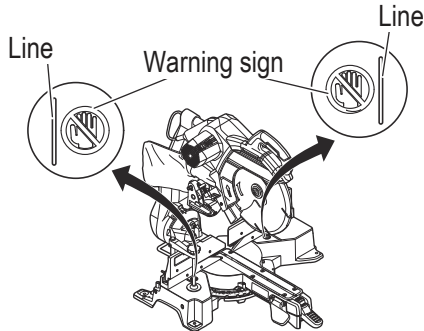
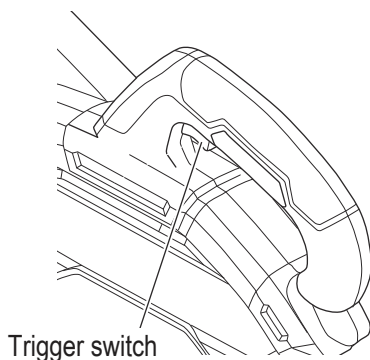

Fig. 18

CAUTION

- It is dangerous to remove or install the workpiece while the saw blade is turning.
- When sawing, clean off the shavings from the turntable.
- If the shavings accumulate too much, the saw blade from the cutting material will be exposed. Never subject your hand or anything else to go near the exposed blade.

1. Switch operation
Pulling the trigger turns the switch on. Releasing the trigger turns the switch off. (Fig. 19)
When the switch is released, the brake is applied to the saw blade rotation and the saw blade stops.

**Fig. 19**

2. Turn on the LED light
Press the LED light switch to switch the LED light.
3. Using the Vise Assembly (Standard accessory) (**Fig. 20**)

WARNING

Use clamps to support the workpiece whenever possible. If supporting the workpiece by hand, you must always keep your hand at least 100 mm from either side of the saw blade. Do not use this saw to cut pieces that are too small to be securely clamped or held by hand.

If your hand is placed too close to the saw blade, there is an increased risk of injury from blade contact, and the workpiece might be thrust from the table and cause bodily harm.

CAUTION

Always confirm that the motor head does not contact the vise assembly when it is lowered for cutting. If there is any danger that it may do so, move the vise assembly to a position where it will not contact the saw blade.

- (1) The vise assembly can be mounted on the base.

English

- (2) Turn the upper knob and securely fix the workpiece in position. (Fig. 20)

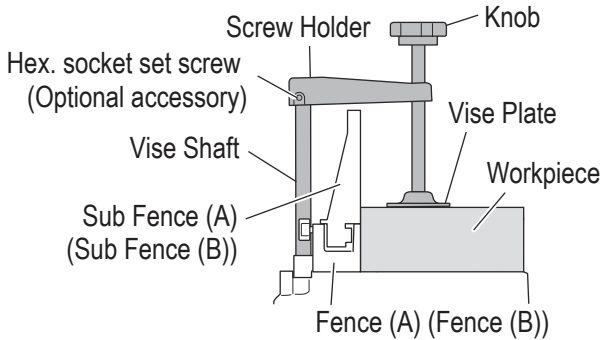

Fig. 20

NOTE

When using the vise, make sure that the tool is free of any excessive contact when the unit is swung or slid.

4. Cutting operation

- (1) As shown in Fig. 21 the width of the saw blade is the width of the cut. Therefore, slide the workpiece to the right (viewed from the operator's position) when length (b) is desired, or to the left when length (a) is desired. Turn the LED light, project the shadow of the blade onto the workpiece, align the left side or right side of shadow of the blade with the ink line on the workpiece.

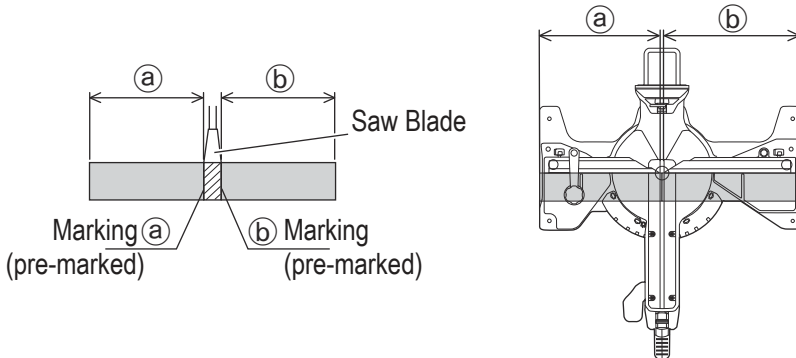

Fig. 21

- (2) After turning on the switch and checking that the saw blade is rotating at maximum speed, slowly push down the handle and bring the saw blade in the vicinity of the material to be cut.
- (3) Once the saw blade contacts the workpiece, push the handle down gradually to cut into the workpiece.

- (4) After cutting the workpiece to the desired depth, turn the power tool OFF and let the saw blade stop completely before raising the handle from the workpiece to return it to the full retract position.

WARNING

- Confirm that the trigger switch is turned OFF and the power plug has been removed from the receptacle whenever the tool is not in use.
- Always turn the power off and let the saw blade stop completely before raising the handle from the workpiece. If the handle is raised while the saw blade is still rotating, the cut-off piece may become jammed against the saw blade causing fragments to scatter about dangerously.
- Every time one cutting of deep-cutting operation is finished, turn the switch off, and check that the saw blade has stopped. Then raise the handle, and return it to the full retract position.
- Be absolutely sure to remove the cut material from the top of the turntable, and then proceed to the next step.
- Continued cutting operation can result in overload of the motor. Touch the motor and if it's hot, stop your cutting operation at once and rest for 10 minutes or so, and then restart your cutting operation.

CAUTION

- For maximum dimensions for cutting, refer to "SPECIFICATIONS" table.
- Increased pressure on the handle will not increase the cutting speed. On the contrary, too much pressure may result in overload of the motor and/or decreased cutting efficiency.

5. Cutting narrow workpieces (Press cutting) (Fig. 22)
Slide the hinge down to holder (A), then tighten the slide securing knob. Lower the handle to cut the workpiece. Using the power tool this way will permit cutting of workpieces of up to 107 mm square.

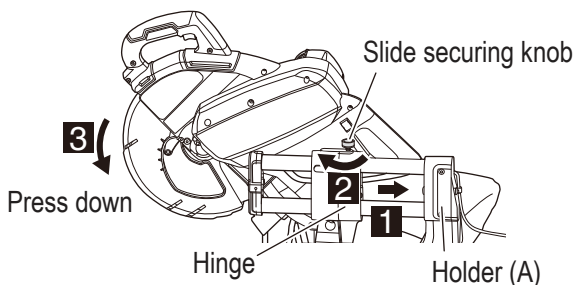

Fig. 22

English

6. Cutting large workpieces (Fig. 23, Fig. 24)

There may be case when a complete cutting cannot be done depending on the height of workpiece. In this case, mount an auxiliary board with the 6 mm flat head screws and the 6 mm nuts using the 7 mm holes on the fence surface (two holes on each side). (Fig. 23) Refer to "SPECIFICATIONS" for the thickness of the auxiliary board.

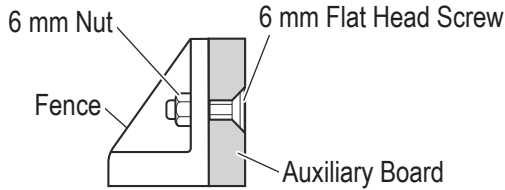

Fig. 23

NOTE

When cutting a workpiece exceeding 107 mm in height in right-angle cutting or 70 mm in left bevel angle cutting or 45 mm in right bevel angle cutting, adjust the lower limit position so that the base of the motor head will not come in contact with the workpiece.

To adjust the lower limit position of the saw blade, follow the procedure (1) shown in Fig. 24.

- (1) Lower the motor head, and turn the 6 mm depth adjustment bolt and make adjustments so that there can be a clearance of 2 mm to 3 mm between the lower limit position of the motor head and the top of the workpiece at the saw blade's lower limit position where the tip of the 6 mm depth adjustment bolt contacts the hinge.

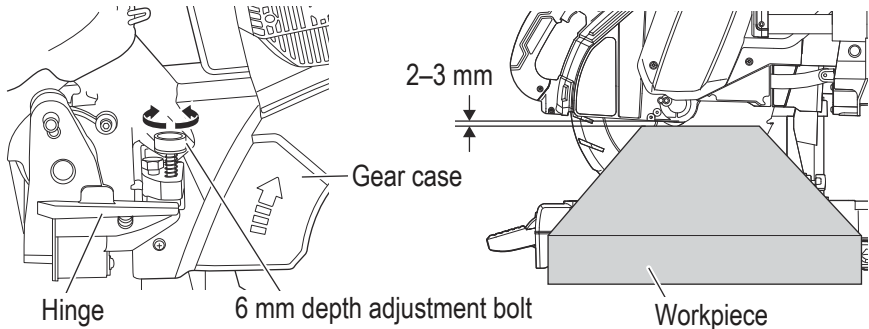

Fig. 24

7. Cutting wide workpieces (Slide cutting) (Fig. 25)

(1) Workpieces up to 107 mm high and 312 mm wide:

Loosen the slide securing knob (A) (Fig. 3 on page 54), grip the handle and slide the saw blade forward. Then press down on the handle and slide the saw blade backward to cut the workpiece. This facilitates cutting of workpieces of up to 107 mm in height and 312 mm in width.

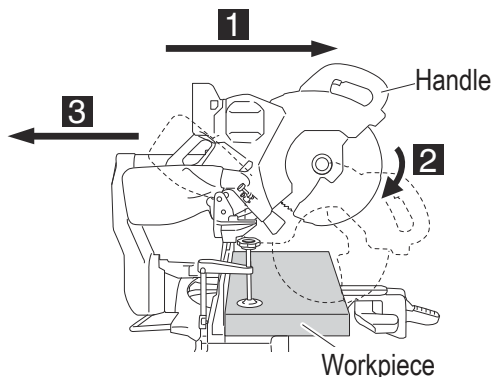

Fig. 25

(2) Workpieces up to 120 mm high and 260 mm wide: Workpieces of up to 120 mm in height and up to 260 mm in width can be cut in the same manner as described in paragraph 7-(1) above.

WARNING

- For slide cutting, follow the procedures. Forward slide cutting (toward the operator) is very dangerous because the saw blade could kick upward from the workpiece. Therefore, always slide the handle away from the operator.
- Always return the carriage to the full rear position after each crosscut operation in order to reduce the risk of injury.
- Never put your hand on the miter lock handle during the cutting operation because the saw blade comes close to the miter lock handle when the motor head is lowered.

CAUTION

- When cutting a workpiece of 120 mm height, adjust the lower limit position of the motor head so that the gap between the lower edge of the motor head and the workpiece will be 2 to 3 mm at the lower limit position.
- If the handle is pressed down with excessive or lateral force, the saw blade may vibrate during the cutting operation and cause unwanted cutting marks on the workpiece, thus reducing the quality of the cut. Accordingly, press the handle down gently and carefully.
- In slide cutting, gently push the handle back (rearwards) in a single, smooth operation. Stopping the handle movement during the cut will cause unwanted cutting marks on the workpiece.

English

8. Bevel cutting procedures

WARNING

When changing the oblique angle, hold down the motor head. If the motor head moves to an oblique angle suddenly, it may result in injury or damage to the main body.

- (1) Loosen the bevel lock handle and bevel the saw blade to the left or to the right. To change the bevel angle to the right, loosen the bevel lock handle, then pull out the set pin (A) toward the front, and tilt the motor head to the right.
When the motor head is straight upright, the set pin (A) is held tightly in place, so tilt the motor head slightly to the left when pulling out the set pin (A) before tilting the motor head to the right.
- (2) Adjust the bevel angle to the desired setting while watching the bevel angle scale and indicator, then secure the bevel lock handle.

CAUTION

Always check that the bevel lock handle is secured and the motor head is clamped. If you attempt angle cutting without clamping the motor head, then the motor head might shift unexpectedly causing injuries.

- (3) Follow the procedures indicated in paragraphs 5, 6 and 7 above. For maximum dimensions for bevel cutting, refer to page 55 "Table 1: Max. sawing dimension".

NOTE

The bevel lock handle adopts a clutch system. When contacting the bevel lock handle and the main body, pull the bevel lock handle in the direction of the arrow mark as illustrated in **Fig. 26**, and change the direction of the bevel lock handle.

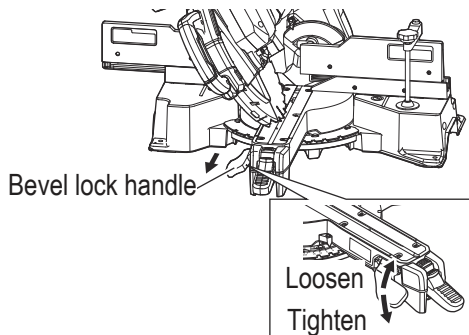

Fig. 26

WARNING

- When the workpiece is secured on the left or right side of the blade, the short cut-off portion will come to rest on the right or left side of the saw blade. Always turn the power off and let the saw blade stop completely before raising the handle from the workpiece. If the handle is raised while the saw blade is still rotating, the cut-off piece may become jammed against the saw blade causing fragments to scatter about dangerously.
- When stopping the bevel cutting operation halfway, start cutting after pulling back the motor head to the initial position.
Starting from halfway, without pulling back, causes the lower guard to be caught in the cutting groove of the workpiece and to contact the saw blade.
- When right angle cutting, loosen the 6 mm wing bolt, then slide the sub fence (A) outward and remove it.
- When left angle cutting, loosen the 6 mm wing bolt, then slide the sub fence (B) outward.

CAUTION

When cutting a workpiece of 75 mm height in the left 45° bevel cutting position or a workpiece of 50 mm height in the right 45° bevel cutting position, adjust the lower limit position of the motor head so that the gap between the lower edge of the motor head and the workpiece will be 2 to 3 mm at the lower limit position (refer to “11. Checking the saw blade lower limit position” on page 61).

9. Miter cutting procedures (**Fig. 27**)

- (1) Unlock the miter table by lifting up on the miter lock handle.
- (2) While lightly pressing down on the positive stop lever until it engages the detent lever, grasp the miter lock handle and rotate the table left or right to the desired angle.
- (3) Once the desired miter angle is achieved, press down on the miter lock handle to secure the table into position.
- (4) If the desired miter angle is one of the nine positive stops noted below, please see the Miter detent lever section on **Fig. 16 on page 67**.
- (5) Turn the LED light on and position the workpiece on the table for pre-alignment of your cut.

CAUTION

Always check that the miter lock handle is secured and the turntable is clamped. If you attempt angle cutting without clamping the turntable, then the turntable might shift unexpectedly causing injuries.

NOTE

- Positive stops are provided at the right and left of the 0° center setting, at 15°, 22.5°, 31.6° and 45° settings. Check that the miter scale and the tip of the indicator are properly aligned.

English

- Operation of the saw with the miter scale and indicator out of alignment, will result in poor cutting precision.

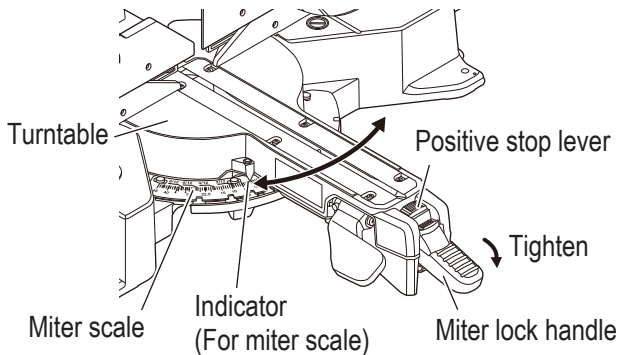

Fig. 27

10. Compound cutting procedures
Compound cutting can be performed by following the instructions in 8 and 9 above. For maximum dimensions for compound cutting, refer to "SPECIFICATIONS" table.

CAUTION

Always secure the workpiece with the right or left hand and cut it by sliding the round portion of the saw backwards with the other hand.

It is very dangerous to rotate the turntable to the right or left during compound cutting because the saw blade may come into contact with the hand that is securing the workpiece.

In case of compound cutting (angle + bevel) by left bevel, extend the sub-fence (B) fully before cutting operation.

In case of compound cutting (angle + bevel) by right bevel, slide the sub-fence (A) outward and remove it.

11. Cutting long materials
When cutting long materials, use an auxiliary platform which is the same height as the holder (optional accessory) and base of the special auxiliary equipment.
Capacity: wooden material (W × H × L)
300 mm × 45 mm × 1300 mm, or
180 mm × 25 mm × 2000 mm
12. Installing the holders ... (Optional accessory)
The holders help keep longer workpieces stable and in place during the cutting operation.

- (1) As indicated in **Fig. 28**, use a steel square for aligning the upper edge of the holders with the base surface.
Loosen the 6 mm wing nut. Turn a height adjustment bolt 6 mm, and adjust the height of the holder.

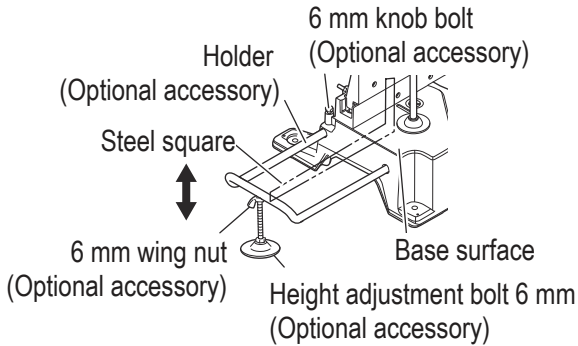

Fig. 28

- (2) After adjustment, firmly tighten the 6 mm wing nut and fasten the holder with the 6 mm knob bolt (optional accessory). If the length of Height Adjustment Bolt 6 mm is insufficient, spread a thin plate beneath. Make sure the end of Height Adjustment Bolt 6 mm does not protrude from the holder.

CAUTION

When transporting or carrying the tool, do not grasp the holder.

There is the danger of the holder slipping out of the base.

For the correct way to hold the tool, refer to “TRANSPORTATION OF THE MAIN BODY” on page 83.

13. Stopper for precision cutting (Stopper and holder are optional accessory)
The stopper facilitates continuous precision cutting in lengths of 285 mm to 450 mm. To install the stopper, attach it to the holder with the 6 mm knob bolt as shown in **Fig. 29**.

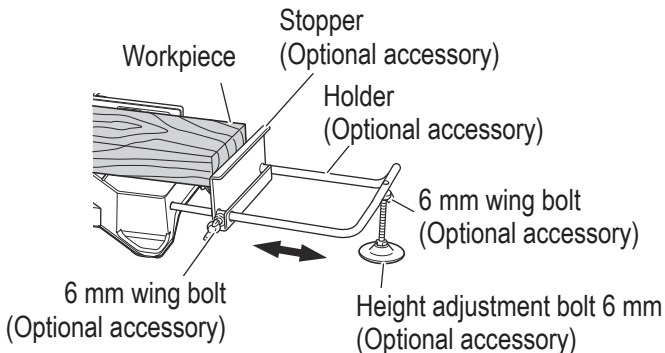

Fig. 29

English

14. Confirmation for use Crown molding vise, Crown molding Stopper (L) and (R) (Optional accessory)
- (1) Crown molding Stopper (L) and (R) (optional accessories) allow easier cuts of crown molding without tilting the saw blade. Install them in the base both-sides side to be shown in **Fig. 30**. After inserting tighten the 6 mm knob bolts to secure the Crown molding Stoppers.
 - (2) The crown molding vise (B) (Optional accessory) can be mounted on either the left fence (Fence (B)) or the right fence (Fence (A)). It can unite with the slope of the crown molding and vice can be pressed down.

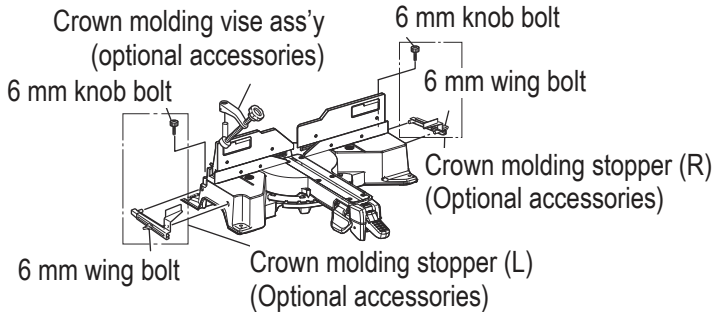

Fig. 30

Then turn the upper knob, as necessary, to securely attach the crown molding in position. To raise or lower the vise assembly, first loosen the hex. socket set screw. After adjusting the height, firmly tighten the 6 mm wing bolt; then turn the upper knob, as necessary, to securely attach the crown molding in position (**Fig. 31**).

Position crown molding with its WALL CONTACT EDGE against the guide fence and its CEILING CONTACT EDGE against the crown molding Stoppers as shown in **Fig. 31**. Adjust the crown molding Stoppers according to the size of the crown molding.

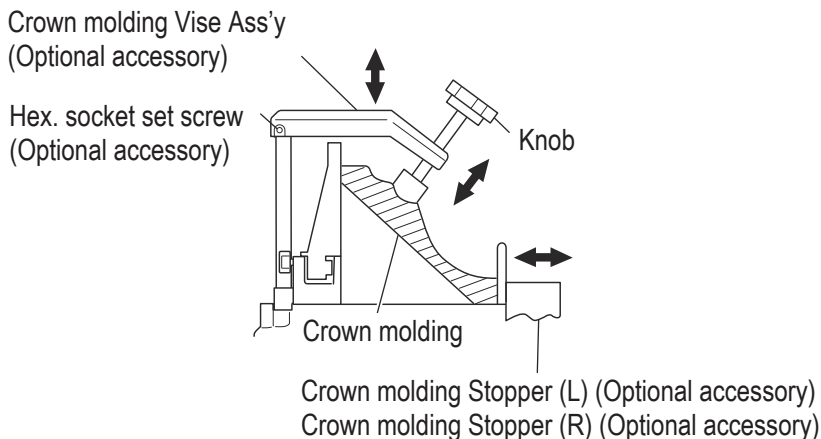

Fig. 31

Tighten the 6 mm wing bolt to secure the Crown molding Stoppers. Refer to the lower table for the miter angle. Use the sub fence (A) to secure the crown molding more firmly (Fig. 20 on page 70).

WARNING

Always firmly clamp or vise to secure the crown molding to the fence; otherwise the crown molding might be thrust from the table and cause bodily harm. Do not bevel cutting. The main body or saw blade may contact the sub fence, resulting in an injury.

CAUTION

Always confirm that the motor head does not contact the crown molding vise ass'y when it is lowered for cutting. If there is any danger that it may do so, loosen the hex. socket set screw and move the crown molding vise ass'y to a position where it will not contact the saw blade.

15. Groove cutting procedures
Grooves in the workpiece can be cut by adjusting the 6 mm depth adjustment bolt (Fig. 32).
- (1) Lower the motor head, and turn the 6 mm depth adjustment bolt by hand. (Where the head of the 6 mm depth adjustment bolt contacts the hinge.)

English

- (2) Adjust to the desired cutting depth by setting the distance between the saw blade and the surface of the base (Fig. 32).

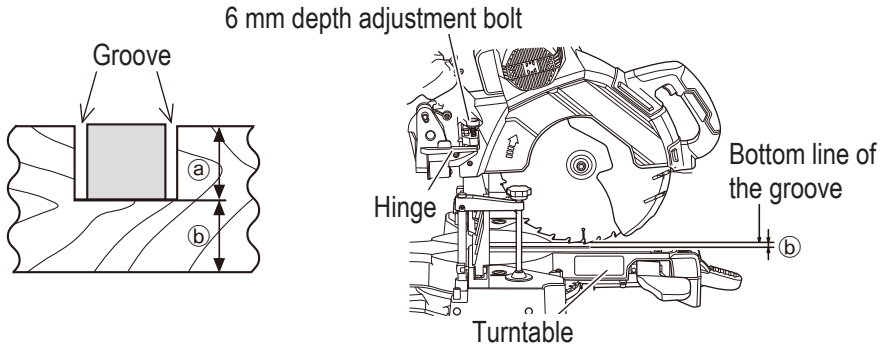

Fig. 32

NOTE

When cutting a single groove at either end of the workpiece, remove the unneeded portion with a chisel.

16. Connecting the dust extractor (Sold separately) (Fig. 33)
- Do not inhale the harmful dusts generated in cutting operation.
The dust can endanger the health of yourself and bystanders.
Use of dust extractor can reduce dust related hazards.
By connecting with dust extractor through adapter, joint and dust collection adapter, most of dust can be collected.
Connect the dust extractor with adapter.
- (1) Connect in order of hose (id 38 mm x 3 m long) and adapter*2, joint (C)*1 and dust collection adapter*1 with the duct of power tool.
Connection is done by pressing in the direction of the arrow. (Fig. 33)
The dust collection adapter*1 is fixed to the duct by a hose band*1.

*1 Optional accessory

*2 Dust extractor's standard accessory

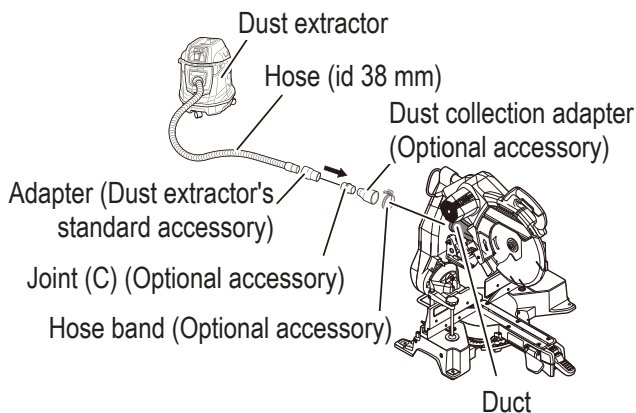

Fig. 33

MOUNTING AND DISMOUNTING SAW BLADE

WARNING

To prevent an accident or personal injury, always turn off the trigger switch and disconnect the power plug from the receptacle before removing or installing a saw blade.

1. Mounting the saw blade (**Fig. 34-a, Fig. 34-b**)
 - (1) Press in spindle lock and loosen 10 mm bolt with 8 mm hex. bar wrench (standard accessory).
Since the 10 mm bolt is left-hand threaded, loosen by turning it to the right.

NOTE

- If the spindle lock cannot be easily pressed in to lock the spindle, turn the 10 mm bolt with 8 mm hex. bar wrench (standard accessory) while applying pressure on the spindle lock.
- The saw blade spindle is locked when the spindle lock is pressed inward.

English

- (2) Remove the bolt and washer (B).

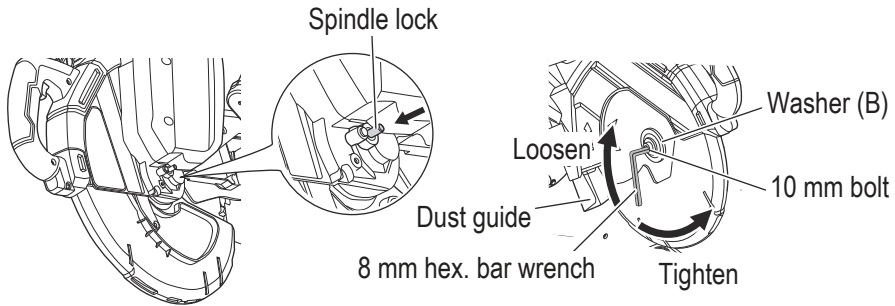

Fig. 34-a

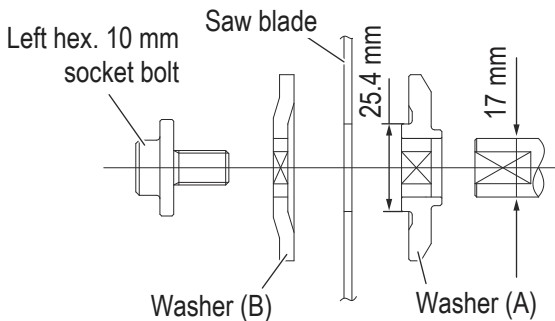

Fig. 34-b

- (3) Lift the lower guard and mount the saw blade.

WARNING

When mounting the saw blade, confirm that the rotation indicator mark on the saw blade and the rotation direction of the gear case (Fig. 2 on page 53) are properly matched.

- (4) Thoroughly clean washer (B) and the 10 mm bolt, and install them onto the saw blade spindle.
- (5) Press in the spindle lock and tighten the 10 mm bolt by turning it to the left by 8 mm hex. bar wrench (standard accessory).

WARNING

Tighten the 10 mm bolt so it does not come loose during operation. Confirm the 10 mm bolt has been properly tightened before the power tool is started.

CAUTION

- A dust guide is installed inside behind the hinge. When removing or installing the saw blade, do not make contact with the dust guide. Contact may break or chip saw blade tips. (Fig. 34-a)
 - Confirm that the spindle lock has returned to the retract position after installing or removing the saw blade.
2. Dismounting the saw blade
Dismount the saw blade by reversing the mounting procedures.
The saw blade can easily be removed after lifting the lower guard.

CAUTION

Never attempt to install saw blades except 305 mm in diameter.

TRANSPORTATION OF THE MAIN BODY**WARNING**

To avoid an accident or personal injury, always confirm that the trigger switch is turned OFF and that the power plug has been disconnected from the receptacle before transportation of the main body.

The vice assembly could be dropped during transportation. Either remove the assembly or slip a piece of wood between the vice to firmly secure it. (Fig. 35-b)

Down the head and insert the locking pin (see page 58 “7. Releasing the locking pin”).

Also screw in the slide securing knob so that the hinge is positioned to hit the holder (A) and secure the head. (Fig. 35-a)

Lift up the miter lock handle, turn the turntable as far right as it will go, and secure the turntable by press down the miter lock handle to the fixed position. This will make the main body even more compact. (Fig. 35-b)

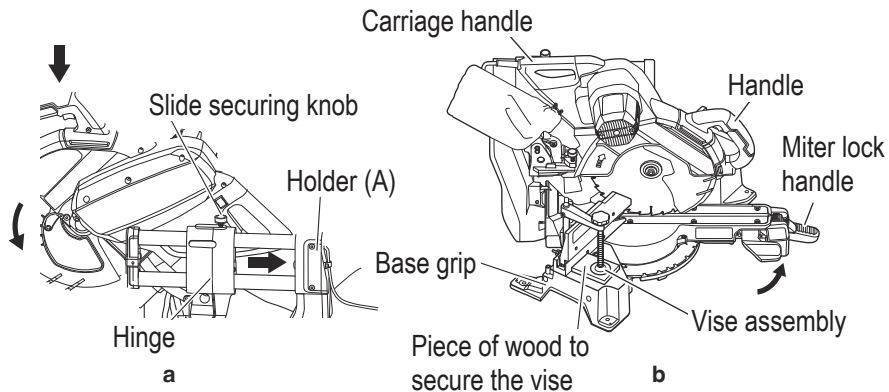

Fig. 35

When transporting the main body, carry it in your arms, holding the grip located on the base with both hands.

When transporting with two people, each person should use both their hands to hold the carry handle, handle and the base grip.

MAINTENANCE AND INSPECTION

WARNING

To avoid an accident or personal injury, always confirm that the trigger switch is turned OFF and that the power plug has been disconnected from the receptacle before performing any maintenance or inspection of this tool.

Report to qualified person as soon as possible, if you discover the fault of machine including guards or blade saw.

1. Inspecting the saw blade
Always replace the saw blade immediately upon the first sign of deterioration or damage. A damaged saw blade can cause personal injury and a worn saw blade can cause ineffective operation and possible overload to the motor.

CAUTION

Never use a dull saw blade. When a saw blade is dull, its resistance to the hand pressure applied by the tool handle tends to increase, making it unsafe to operate the power tool.

2. Inspecting the mounting screws
Regularly inspect all mounting screws and ensure that they are properly tightened. Should any of the screws be loose, retighten them immediately. Failure to do so could result in serious hazard.
3. Inspecting the carbon brushes (**Fig. 36**)
The motor employs carbon brushes which are consumable parts. Since an excessively worn carbon brush can result in motor trouble, replace the carbon brushes with new ones having the same carbon brush No. shown in the figure when it becomes worn to or near the “wear limit”. In addition, always keep carbon brushes clean and ensure that they slide freely within the brush holders.
4. Replacing a carbon brushes (**Fig. 36**)
Disassemble the brush cap with a slotted-head screwdriver. The carbon brushes can then be easily removed.

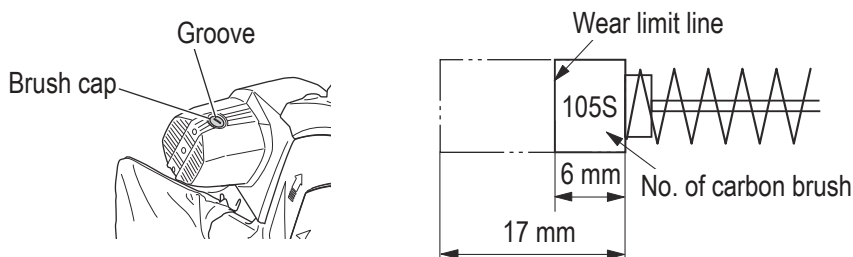

Fig. 36

5. Maintenance of the motor
The motor unit winding is the very “heart” of the power tool. Exercise due care to ensure the winding does not become damaged and/or wet with oil or water.
6. Inspecting the lower guard for proper operation
Before each use of the tool, test the lower guard (**Fig. 8 on page 60**) to assure that it is in good condition and that it moves smoothly.
Never use the tool unless the lower guard operates properly and it is in good mechanical condition.
7. Lubrication
Lubricate the following sliding surfaces once a month to keep the power tool in good operating condition for a long time.
Use of machine oil is recommended.
Oil supply points:
 - * Rotary portion of hinge
 - * Rotary portion of holder (A)
 - * Rotary portion of vise assembly

English

8. Cleaning

Clean the machine, duct and lower guard by blowing with dry air from an air gun or other tool. (Fig. 37)

Periodically remove chips and other waste material from the surface of the power tool with a damp, soapy cloth. To avoid a malfunction of the motor, protect it from contact with oil or water.

If the LED line becomes invisible due to chips and the like adhered onto the window of the LED's light-emitting section, wipe and clean the window with a dry cloth or a soft cloth moistened with soapy water, etc.

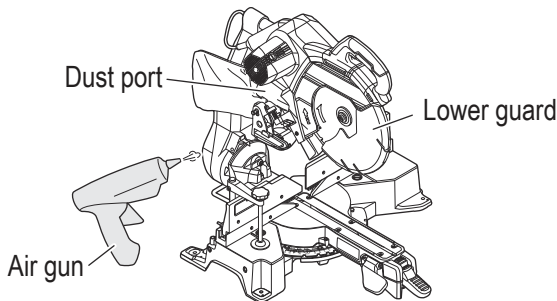

Fig. 37

9. Storage

After operation of the tool has been completed, check that the following has been performed:

- (1) Trigger switch is in OFF position,
- (2) Power plug has been removed from the receptacle,

When the tool is not in use, keep it stored in a dry place out of the reach of children.

TROUBLESHOOTING

Use the inspections in the table below if the tool does not operate normally. If this does not remedy the problem, consult your dealer or the HiKOKI Authorized Service Center.

Symptom	Possible cause	Remedy
Tool suddenly stopped	Tool was overburdened	Get rid of the problem causing the overburden.
	The motor was automatically stopped to prevent failure of the tool.	This is not a malfunction. The trigger switch was held down for 5 minutes or more. Switch on the power once more.

Symptom	Possible cause	Remedy
Cannot be tilted	The bevel lock handle has not been loosened.	Loosen the bevel lock handle and then tilt the tool. After adjusting the loosened component, make sure to tighten it once again.
Cannot be tilted to the right	Set pin (A) has not been pulled out.	Tilt to the right after pulling out set pin (A).
	The bevel lock handle has not been loosened.	Loosen the bevel lock handle and then tilt.
Sawblade is dull	The sawblade is worn down or missing teeth.	Exchange with a new product.
	Bolt is loose.	Tighten the bolt.
	The sawblade has been installed in reverse.	Install the sawblade in the correct direction.
Cannot cut with precision	The operation parts of the tool are not fully fixed.	Fully install the bevel lock handle and miter lock handle.
	Material cannot be fixed in the correct position.	Remove any foreign material from the fence or turntable. In some cases, proper position cannot be fixed due to a curve in the material. Try to fix a flat surface with the fence or turntable.

SELECTING ACCESSORIES

Select accessories that are suited to a specific task.
For details contact HiKOKI Authorized Service Center.

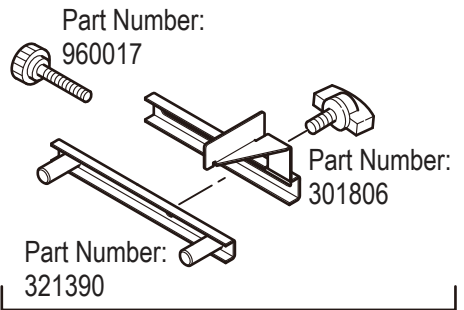
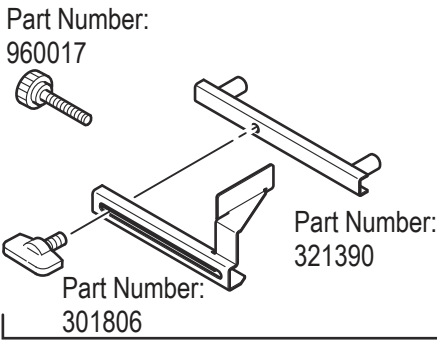
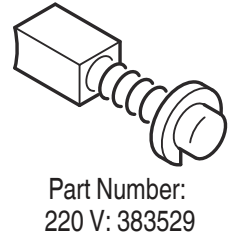
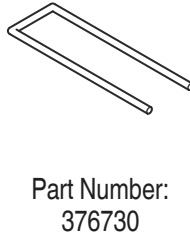
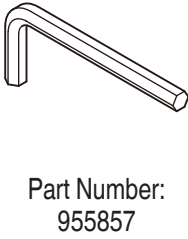
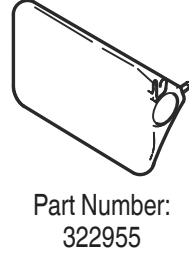
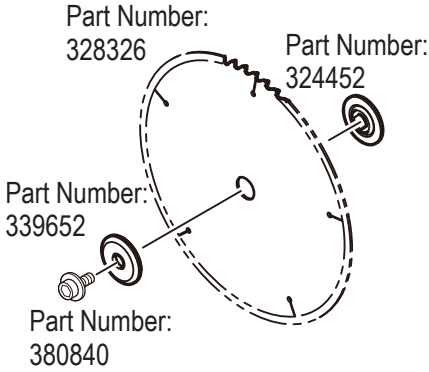

Part Number: 339730

Part Number: 339731

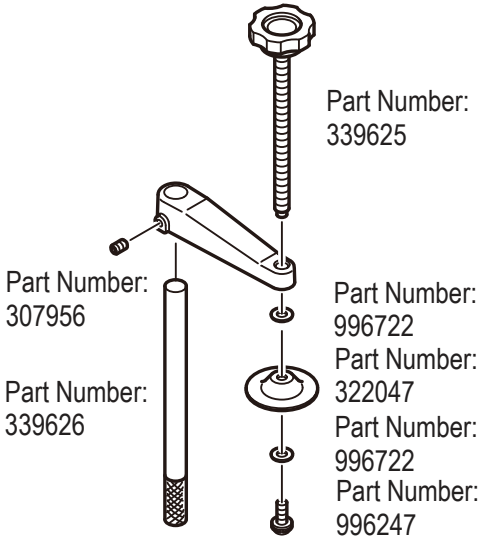

Part Number: 339624

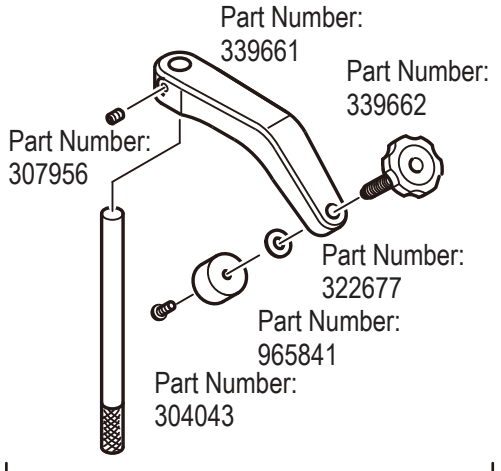

Part Number: 339660

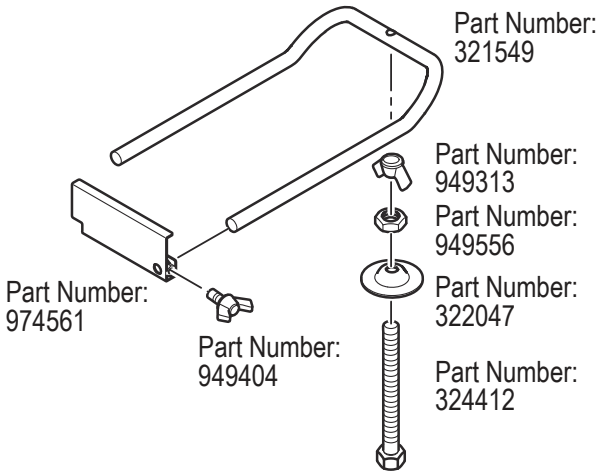

Part Number: 324464

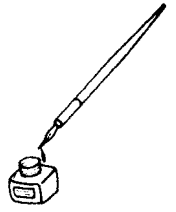

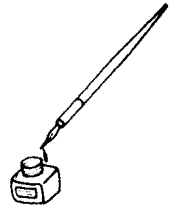

服务中心
高壹工机商业(上海)有限公司
上海市闵行区召楼路3576号5幢

制造商
工机控股株式会社
日本茨城县常陆那珂市

Koki Holdings Co., Ltd.

602
编号：C99748221
发行日期：2026年2月
中国印刷