

HILTI

SCM 22-A

Operating instructions en

Brugsanvisning da

Bruksanvisning sv

Bruksanvisning no

Käyttöohje fi

Инструкция по эксплуатации ru

Ръководство за обслужване bg

Instrucțiuni de utilizare ro

Kullanma Talimatı tr

دليل الاستعمال ar

Lietošanas pamācība lv

Instrukcija lt

Kasutusjuhend et

Пайдалану бойынша басшылық kk

取扱説明書 ja

사용설명서 ko

操作說明書 zh

操作说明书 cn



1

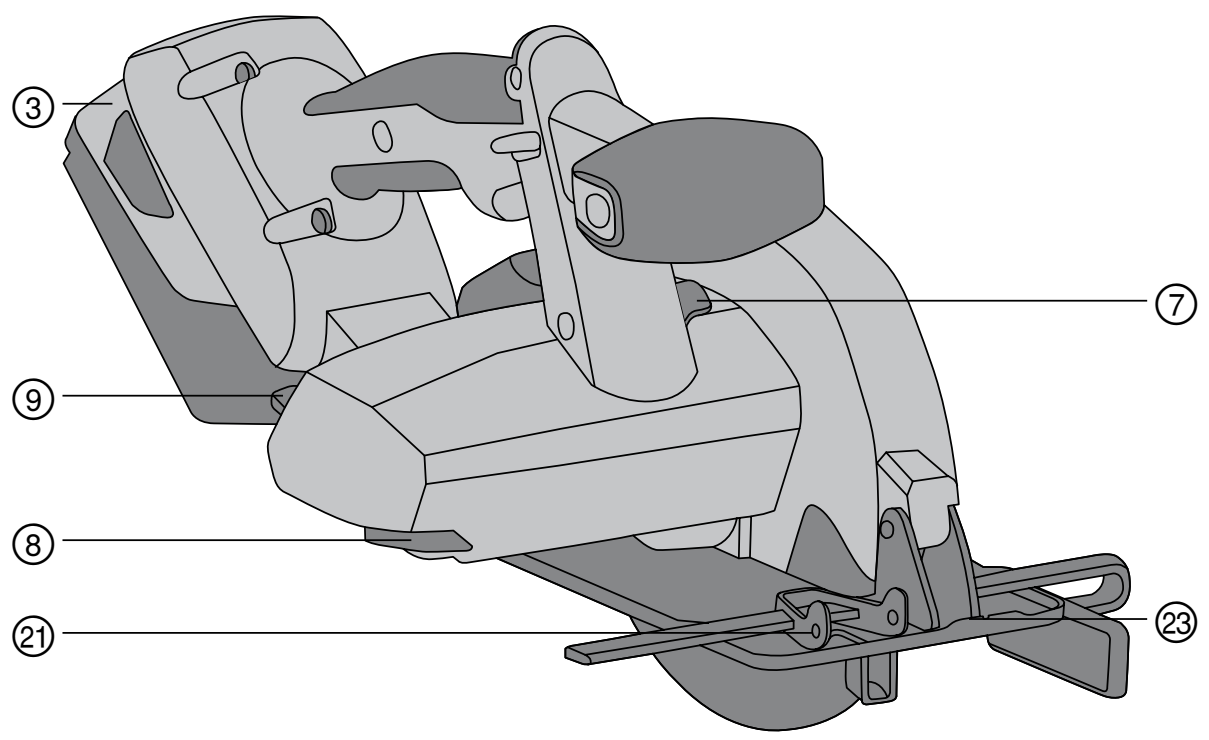
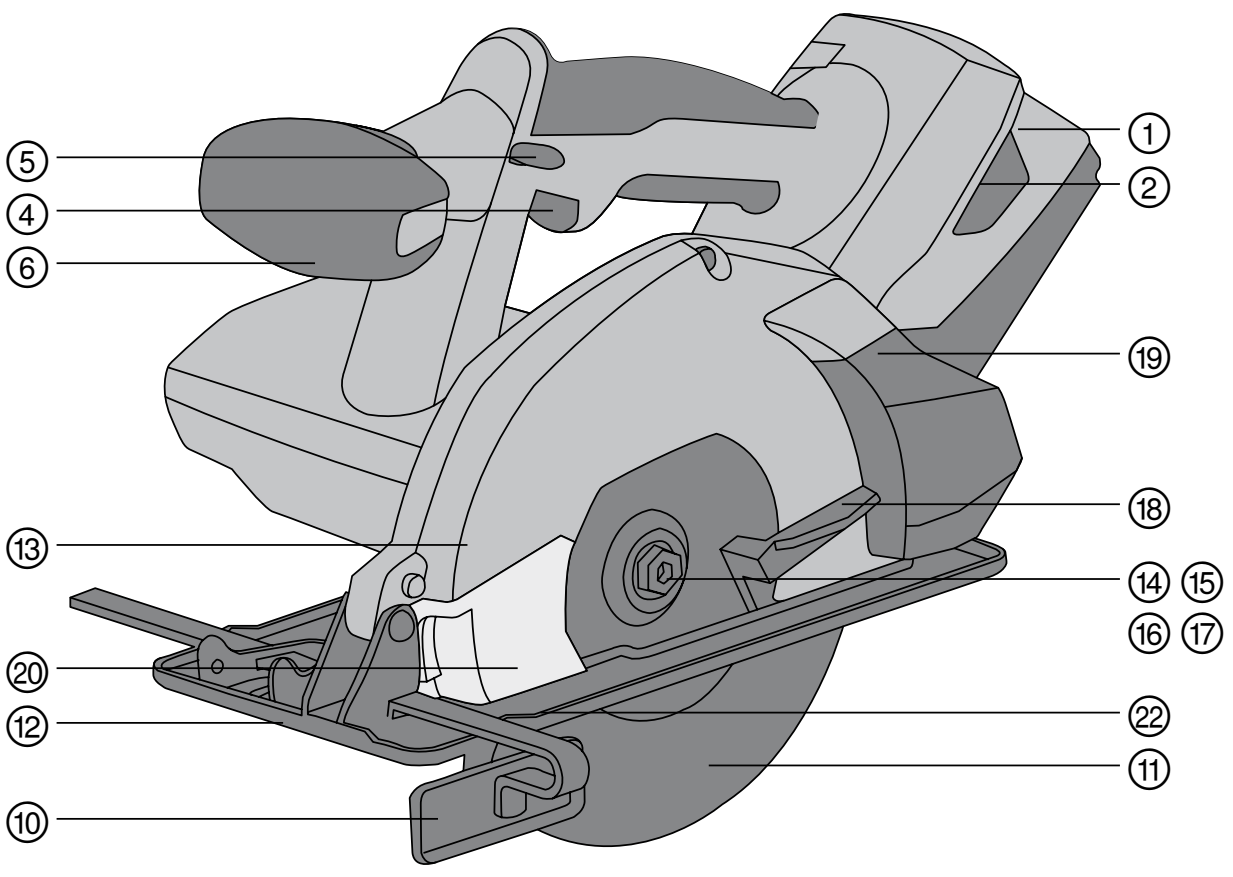

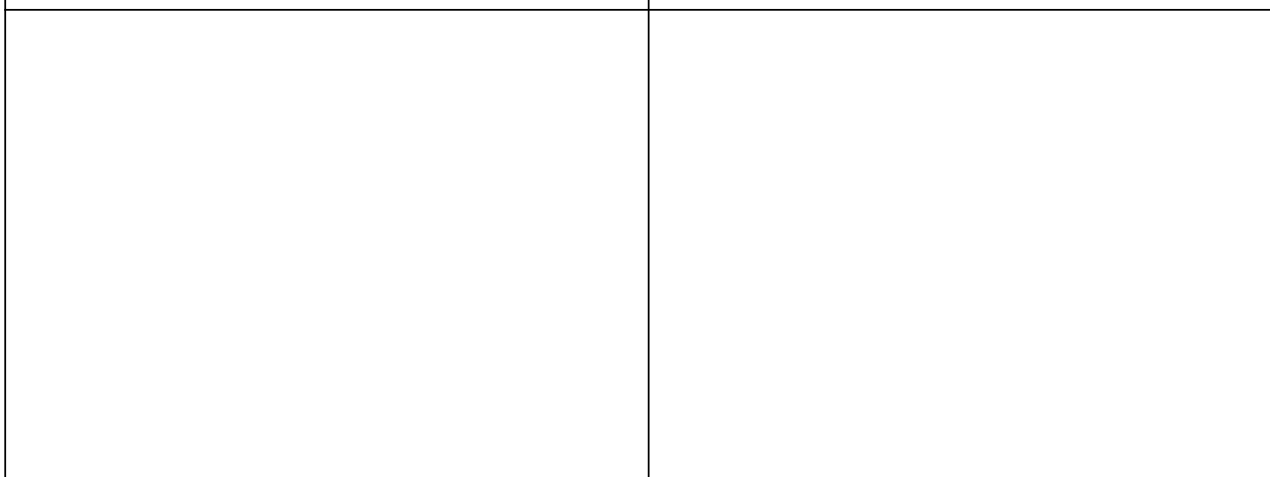
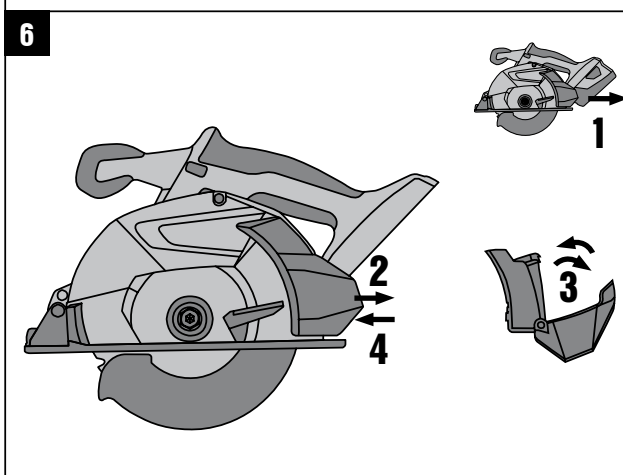
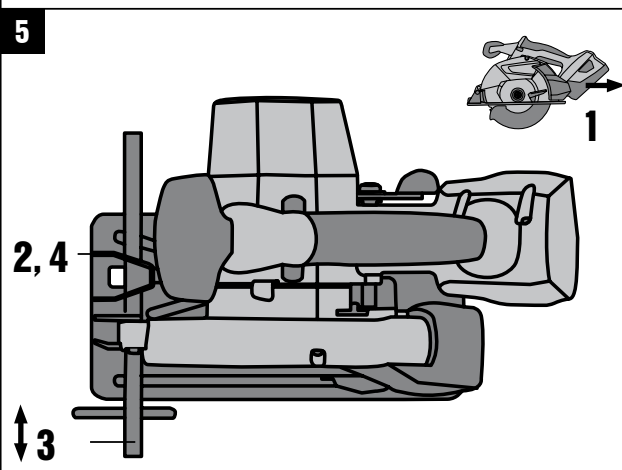
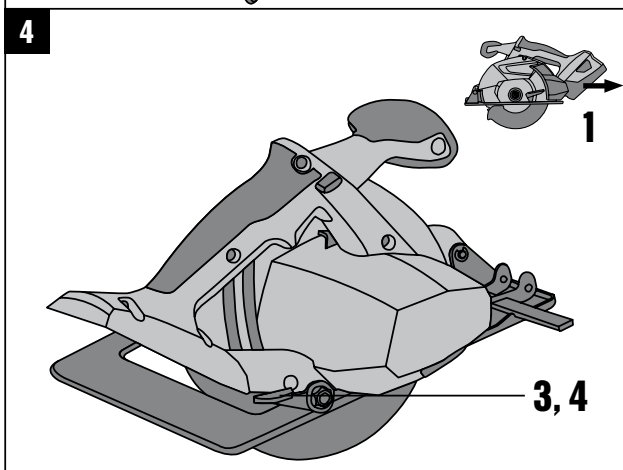
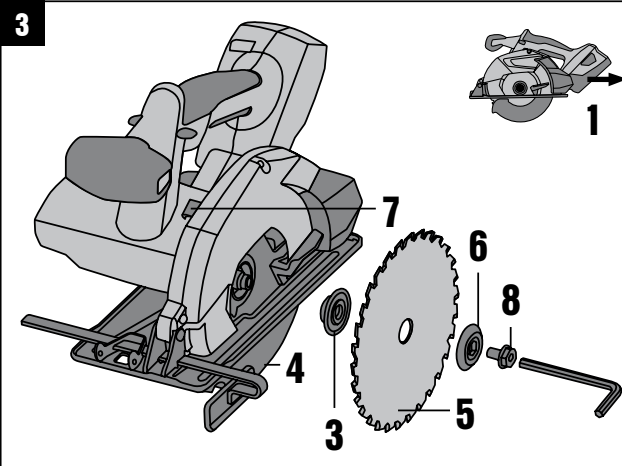
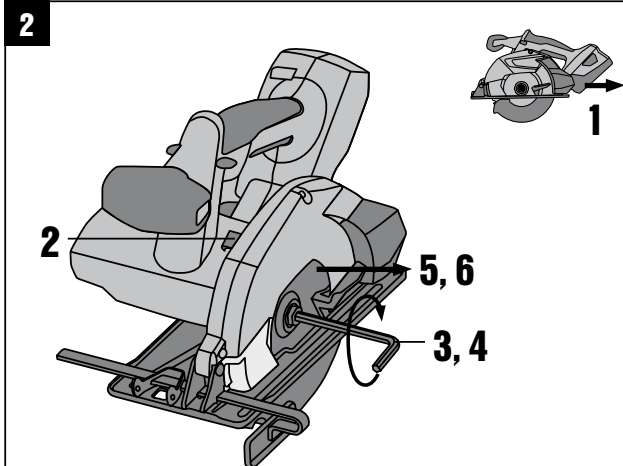

ORIGINAL OPERATING INSTRUCTIONS

SCM 22-A cordless circular saw

It is essential that the operating instructions are read before the power tool is operated for the first time.

Always keep these operating instructions together with the power tool.

Ensure that the operating instructions are with the power tool when it is given to other persons.

Contents	Page
1 General information	1
2 Description	2
3 Insert tools, accessories	3
4 Technical data	4
5 Safety instructions	5
6 Before use	8
7 Operation	9
8 Care and maintenance	11
9 Troubleshooting	12
10 Disposal	12
11 Manufacturer's warranty - tools	13
12 EC declaration of conformity (original)	13

1 These numbers refer to the corresponding illustrations. The illustrations can be found on the fold-out cover

pages. Keep these pages open while studying the operating instructions.

In these operating instructions, the designation "the power tool" always refers to the SCM 22-A cordless circular saw.

Operating controls and indicators **1**

- ① Battery
- ② Release buttons with additional function (charge status display activation)
- ③ Charge status and fault display (lithium-ion battery)
- ④ On / off switch
- ⑤ Switch-on interlock
- ⑥ Auxiliary grip
- ⑦ Drive spindle lockbutton
- ⑧ Hexagon socket wrench
- ⑨ Clamping lever for cutting depth adjustment
- ⑩ Parallel guide (rip fence)
- ⑪ Pivoting guard
- ⑫ Base plate
- ⑬ Guard
- ⑭ Drive spindle
- ⑮ Mounting flange
- ⑯ Clamping flange
- ⑰ Clamping screw
- ⑱ Pivoting guard operating lever
- ⑲ Chip collector
- ⑳ LED / viewing window
- ㉑ Parallel guide (rip fence) clamp
- ㉒ Saw blade position indicator
- ㉓ Cutting line indicator

en

1 General information

1.1 Safety notices and their meaning

DANGER

Draws attention to imminent danger that will lead to serious bodily injury or fatality.

WARNING

Draws attention to a potentially dangerous situation that could lead to serious personal injury or fatality.

CAUTION

Draws attention to a potentially dangerous situation that could lead to slight personal injury or damage to the equipment or other property.

NOTE

Draws attention to an instruction or other useful information.

1.2 Explanation of the pictograms and other information

Warning signs



General warning



Warning: electricity



Warning: caustic substances



Warning: hot surface

Obligation signs

Wear eye protection



Wear a hard hat



Wear ear protection



Wear protective gloves



Wear breathing protection

Symbols

Read the operating instructions before use

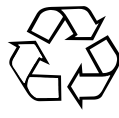

Return waste material for recycling.



Volts



Direct current

 n_0

Rated speed under no load

/min

Revolutions per minute



Diameter



Saw blade

Location of identification data on the power tool

The type designation and serial number can be found on the type identification plate on the machine or tool. Make a note of this data in your operating instructions and always refer to it when making an enquiry to your Hilti representative or service department.

Type:

Generation: 01

Serial no.:

2 Description**2.1 Use of the product as directed**

The power tool is a hand-held, cordless circular saw.

The tool is designed for cutting metals or metal-like materials up to a cutting depth of 57 mm.

Working on materials hazardous to the health (e.g. asbestos) is not permissible.

The power tool is designed for professional use and may be operated, serviced and maintained only by trained, authorized personnel. This personnel must be informed of any special hazards that may be encountered. The power tool and its ancillary equipment may present hazards when used incorrectly by untrained personnel or when used not as directed.

The working environment may be as follows: construction site, workshop, renovation, conversion or new construction. Modification of the power tool or tampering with its parts is not permissible.

The use of saw blades not in compliance with the given specification (e.g. diameter, speed of rotation, thickness) or the use of cutting and grinding discs or blades made from high-alloy steel (HSS steel) is not permissible.

Do not use the saw to cut wood or wood-like materials, plastics, gypsum board, gypsum fiberboard and composite materials.

Do not use the battery as a power source for other unspecified appliances.

To avoid the risk of injury, use only genuine Hilti accessories and insert tools.

Observe the information printed in the operating instructions concerning operation, care and maintenance.

2.2 Switch

On / off switch with switch-on interlock

2.3 Grips

Grip and auxiliary grip

2.4 Safety precautions

Blade guard and pivoting guard

2.5 Lubrication

Grease lubrication

2.6 Protection against overload and overheating

The power tool is equipped with an electronic protection system to prevent overloading and overheating. The power tool switches itself off automatically in the event of overloading and overheating. After releasing the on / off switch, the power tool may not restart immediately when the switch is pressed again (while the power tool is cooling down).

2.7 Lithium-ion battery charge status

When a lithium-ion battery is used, the charge status can be indicated by gently pressing one of the battery release buttons (press until resistance is felt - do not release the battery). The display on the rear of the battery provides the following information:

LEDs light constantly	LEDs blink	Charge status C
LED 1, 2, 3, 4	-	$C \geq 75 \%$
LED 1, 2, 3	-	$50 \% \leq C < 75 \%$
LED 1, 2	-	$25 \% \leq C < 50 \%$
LED 1	-	$10 \% \leq C < 25 \%$
-	LED 1	$C < 10 \%$

2.8 Items supplied as standard

- 1 Power tool
- 1 Saw blade
- 1 Hexagon socket wrench
- 1 Operating instructions
- 1 Hilti toolbox (optional)
- 1 Cardboard box (optional)
- 1 Rip fence

2.9 Additional items required for operating the tool

B22/2.6 or B22/3.3 Li-ion battery and C4/36, C4/36-ACS, C4/36-90 or C4/36-350 charger.

NOTE

Depending on the version, these items may be supplied with the power tool.

3 Insert tools, accessories

Accessories for the SCM 22-A

Designation	Short designation
Charger for Li-ion batteries	C 4/36
Charger for Li-ion batteries	C4/36-ACS
Charger for Li-ion batteries	C 4/36-90
Charger for Li-ion batteries	C 4/36-350
Battery	B 22/2.6 Li-Ion

Designation	Short designation
Battery	B 22/3.3 Li-Ion
Rip fence	

Recommended saw blade

Designation	Short designation
Saw blade	SC-C MU 165x20 z40 A

4 Technical data

Right of technical changes reserved.

Power tool	SCM 22-A
Rated voltage (DC voltage)	21.6 V
Weight in accordance with EPTA procedure 01/2003	4.0 kg
Dimensions (L x W x H)	370 mm x 206 mm x 242 mm
Base plate dimensions	248 mm x 127 mm
Specified blade diameter	160... 165 mm
Saw blade disc thickness	1.2 mm
Kerf width	1.6 mm
Saw blade arbor size	20 mm
Cutting depth	57 mm
Speed under no load	3,500/min

NOTE

The vibration emission level given in this information sheet has been measured in accordance with a standardized test given in EN 60745 and may be used to compare one tool with another. It may be used for a preliminary assessment of exposure. The declared vibration emission level represents the main applications of the tool. However if the tool is used for different applications, with different accessories or is poorly maintained, the vibration emission may differ. This may significantly increase the exposure level over the total working period. An estimation of the level of exposure to vibration should also take into account the times when the tool is switched off or when it is running but not actually doing the job. This may significantly reduce the exposure level over the total working period. Identify additional safety measures to protect the operator from the effects of vibration such as: maintaining the tool and the accessories, keeping hands warm, organization of work patterns.

Noise and vibration information for the SCM 22-A (measured in accordance with EN 60745-2-5):

Depending on how the saw is used, the values may increase.

Typical A-weighted sound power level	88 dB (A)
Typical A-weighted emission sound pressure level	77 dB (A)
Uncertainty for the given sound level	3 dB (A)

Triaxial vibration values (vibration vector sum)

Sawing metal, a_n	1.2 m/s ²
Uncertainty (K)	1.5 m/s ²

Battery	B 22/3.3 Li-Ion	B 22/2.6 Li-Ion
Rated voltage	21.6 V	21.6 V
Capacity	3.3 Ah	2.6 Ah
Energy capacity	71.28 Wh	56.16 Wh

Battery	B 22/3.3 Li-Ion	B 22/2.6 Li-Ion
Weight	0.78 kg	0.78 kg
Type of cell	Li-Ion	Li-Ion
No. of cells	12	12
Deep discharge protection	Yes	Yes

5 Safety instructions

NOTE

The safety rules in section 5.1 contain all general safety rules for power tools which, in accordance with the applicable standards, must be listed in the operating instructions. Accordingly, some of the rules listed may not be relevant to this tool.

5.1 General power tool safety warnings

a) WARNING

Read all safety warnings and all instructions. Failure to follow the warnings and instructions may result in electric shock, fire and/or serious injury. **Save all warnings and instructions for future reference.** The term “power tool” in the warnings refers to your mains-operated (corded) power tool or battery-operated (cordless) power tool.

5.1.1 Work area safety

- a) **Keep work area clean and well lit.** Cluttered or dark areas invite accidents.
- b) **Do not operate power tools in explosive atmospheres, such as in the presence of flammable liquids, gases or dust.** Power tools create sparks which may ignite the dust or fumes.
- c) **Keep children and bystanders away while operating a power tool.** Distractions can cause you to lose control.

5.1.2 Electrical safety

- a) **Power tool plugs must match the outlet. Never modify the plug in any way. Do not use any adapter plugs with earthed (grounded) power tools.** Unmodified plugs and matching outlets will reduce risk of electric shock.
- b) **Avoid body contact with earthed or grounded surfaces, such as pipes, radiators, ranges and refrigerators.** There is an increased risk of electric shock if your body is earthed or grounded.
- c) **Do not expose power tools to rain or wet conditions.** Water entering a power tool will increase the risk of electric shock.
- d) **Do not abuse the cord. Never use the cord for carrying, pulling or unplugging the power tool. Keep cord away from heat, oil, sharp edges or moving parts.** Damaged or entangled cords increase the risk of electric shock.
- e) **When operating a power tool outdoors, use an extension cord suitable for outdoor use.** Use of

a cord suitable for outdoor use reduces the risk of electric shock.

- f) **If operating a power tool in a damp location is unavoidable, use a residual current device (RCD) protected supply.** Use of an RCD reduces the risk of electric shock.

5.1.3 Personal safety

- a) **Stay alert, watch what you are doing and use common sense when operating a power tool. Do not use a power tool while you are tired or under the influence of drugs, alcohol or medication.** A moment of inattention while operating power tools may result in serious personal injury.
- b) **Use personal protective equipment. Always wear eye protection.** Protective equipment such as dust mask, non-skid safety shoes, hard hat, or hearing protection used for appropriate conditions will reduce personal injuries.
- c) **Prevent unintentional starting. Ensure the switch is in the off-position before connecting to power source and/or battery pack, picking up or carrying the tool.** Carrying power tools with your finger on the switch or energising power tools that have the switch on invites accidents.
- d) **Remove any adjusting key or wrench before turning the power tool on.** A wrench or a key left attached to a rotating part of the power tool may result in personal injury.
- e) **Do not overreach. Keep proper footing and balance at all times.** This enables better control of the power tool in unexpected situations.
- f) **Dress properly. Do not wear loose clothing or jewellery. Keep your hair, clothing and gloves away from moving parts.** Loose clothes, jewellery or long hair can be caught in moving parts.
- g) **If devices are provided for the connection of dust extraction and collection facilities, ensure these are connected and properly used.** Use of dust collection can reduce dust-related hazards.

5.1.4 Power tool use and care

- a) **Do not force the power tool. Use the correct power tool for your application.** The correct power tool will do the job better and safer at the rate for which it was designed.
- b) **Do not use the power tool if the switch does not turn it on and off.** Any power tool that cannot be

controlled with the switch is dangerous and must be repaired.

- c) **Disconnect the plug from the power source and/or the battery pack from the power tool before making any adjustments, changing accessories, or storing power tools.** Such preventive safety measures reduce the risk of starting the power tool accidentally.
- d) **Store idle power tools out of the reach of children and do not allow persons unfamiliar with the power tool or these instructions to operate the power tool.** Power tools are dangerous in the hands of untrained users.
- e) **Maintain power tools. Check for misalignment or binding of moving parts, breakage of parts and any other condition that may affect the power tool's operation. If damaged, have the power tool repaired before use.** Many accidents are caused by poorly maintained power tools.
- f) **Keep cutting tools sharp and clean.** Properly maintained cutting tools with sharp cutting edges are less likely to bind and are easier to control.
- g) **Use the power tool, accessories and tool bits etc. in accordance with these instructions, taking into account the working conditions and the work to be performed.** Use of the power tool for operations different from those intended could result in a hazardous situation.

5.1.5 Battery tool use and care

- a) **Recharge only with the charger specified by the manufacturer.** A charger that is suitable for one type of battery pack may create a risk of fire when used with another battery pack.
- b) **Use power tools only with specifically designated battery packs.** Use of any other battery packs may create a risk of injury and fire.
- c) **When battery pack is not in use, keep it away from other metal objects, like paper clips, coins, keys, nails, screws or other small metal objects, that can make a connection from one terminal to another.** Shorting the battery terminals together may cause burns or a fire.
- d) **Under abusive conditions, liquid may be ejected from the battery; avoid contact. If contact accidentally occurs, flush with water. If liquid contacts eyes, additionally seek medical help.** Liquid ejected from the battery may cause irritation or burns.

5.1.6 Service

- a) **Have your power tool serviced by a qualified repair person using only identical replacement parts.** This will ensure that the safety of the power tool is maintained.

5.2 Safety instructions for all saws

5.2.1 Cutting procedures

- a)  **DANGER**
Keep hands away from cutting area and the blade. Keep your second hand on auxiliary handle, or

motor housing. If both hands are holding the saw, they cannot be cut by the blade.

- b) **Do not reach underneath the workpiece.** The guard cannot protect you from the blade below the workpiece.
- c) **Adjust the cutting depth to the thickness of the workpiece.** Less than a full tooth of the blade teeth should be visible below the workpiece.
- d) **Never hold piece being cut in your hands or across your leg. Secure the workpiece to a stable platform.** It is important to support the work properly to minimize body exposure, blade binding, or loss of control.
- e) **Hold the power tool by insulated gripping surfaces only, when performing an operation where the cutting tool may contact hidden wiring.** Contact with a "live" wire will also make exposed metal parts of the power tool "live" and could give the operator an electric shock.
- f) **When ripping always use a rip fence or straight edge guide.** This improves the accuracy of cut and reduces the chance of blade binding.
- g) **Always use blades with correct size and shape (diamond versus round) of arbour holes.** Blades that do not match the mounting hardware of the saw will run eccentrically, causing loss of control.
- h) **Never use damaged or incorrect blade washers or bolt.** The blade washers and bolt were specially designed for your saw, for optimum performance and safety of operation.

5.2.2 Further safety instructions for all saws

Kickback causes and related warnings

kickback is a sudden reaction to a pinched, bound or misaligned saw blade, causing an uncontrolled saw to lift up and out of the workpiece toward the operator; when the blade is pinched or bound tightly by the kerf closing down, the blade stalls and the motor reaction drives the unit rapidly back toward the operator; if the blade becomes twisted or misaligned in the cut, the teeth at the back edge of the blade can dig into the top surface of the wood causing the blade to climb out of the kerf and jump back toward the operator.

Kickback is the result of saw misuse and/or incorrect operating procedures or conditions and can be avoided by taking proper precautions as given below.

- a) **Maintain a firm grip with both hands on the saw and position your arms to resist kickback forces. Position your body to either side of the blade, but not in line with the blade.** Kickback could cause the saw to jump backwards, but kickback forces can be controlled by the operator, if proper precautions are taken.
- b) **When blade is binding, or when interrupting a cut for any reason, release the trigger and hold the saw motionless in the material until the blade comes to a complete stop. Never attempt to remove the saw from the work or pull the saw backward while the blade is in motion or kickback**

- may occur. Investigate and take corrective actions to eliminate the cause of blade binding.
- c) **When restarting a saw in the workpiece, centre the saw blade in the kerf and check that saw teeth are not engaged into the material.** If saw blade is binding, it may walk up or kickback from the workpiece as the saw is restarted.
 - d) **Support large panels to minimise the risk of blade pinching and kickback.** Large panels tend to sag under their own weight. Supports must be placed under the panel on both sides, near the line of cut and near the edge of the panel.
 - e) **Do not use dull or damaged blades.** Unsharpened or improperly set blades produce narrow kerf causing excessive friction, blade binding and kickback.
 - f) **Blade depth and bevel adjusting locking levers must be tight and secure before making cut.** If blade adjustment shifts while cutting, it may cause binding and kickback.
 - g) **Use extra caution when sawing into existing walls or other blind areas.** The protruding blade may cut objects that can cause kickback.

5.2.3 Safety instructions for circular saws with outer pendulum guard

Lower guard function

- a) **Check lower guard for proper closing before each use. Do not operate the saw if lower guard does not move freely and close instantly. Never clamp or tie the lower guard into the open position.** If saw is accidentally dropped, lower guard may be bent. Raise the lower guard with the retracting handle and make sure it moves freely and does not touch the blade or any other part, in all angles and depths of cut.
- b) **Check the operation of the lower guard spring. If the guard and the spring are not operating properly, they must be serviced before use.** Lower guard may operate sluggishly due to damaged parts, gummy deposits, or a build-up of debris.
- c) **Lower guard may be retracted manually only for special cuts such as “plunge cuts” and “compound cuts.”** Raise lower guard by retracting handle and as soon as blade enters the material, the lower guard must be released. For all other sawing, the lower guard should operate automatically.
- d) **Always observe that the lower guard is covering the blade before placing saw down on bench or floor.** An unprotected, coasting blade will cause the saw to walk backwards, cutting whatever is in its path. Be aware of the time it takes for the blade to stop after switch is released.

5.3 Additional safety instructions

5.3.1 Personal safety

- a) **Wear ear protectors.** Exposure to noise can cause hearing loss.

- b) **Always hold the power tool securely with both hands on the grips provided. Keep the grips dry, clean and free from oil and grease.**
- c) **Breathing protection must be worn if the power tool is used without a dust removal system for work that creates dust.**
- d) **Do not operate the power tool without the protective devices that belong to it.**
- e) **Operate the power tool only as intended and when it is in faultless condition.**
- f) **Improve the blood circulation in your fingers by relaxing your hands and exercising your fingers during breaks between working.**
- g) **Switch the power tool on only after bringing it into position at the workpiece.**
- h) **Remove the battery before storing or transporting the power tool.**
- i) **Always guide the power tool away from your body when working with it.**
- j) **Do not work with the power tool overhead.**
- k) **Do not attempt to brake the speed of the saw blade by pressing it to the side.**
- l) **Do not touch the clamping flange or the clamping screw while the power tool is running.**
- m) **Never press the drive spindle lock button while the saw blade is rotating.**
- n) **Never direct the power tool toward persons.**
- o) **Adjust the pressure applied to the saw blade and the material being cut so that the blade does not stall, possibly causing the power tool to kick back.**
- p) **Avoid overheating the tips of the saw blade teeth.**
- q) **Metal cuttings are sharp and present a risk of injury. Keep your clothing closed so that metal cuttings cannot find their way into your gloves, shoes or other parts of your clothing.**
- r) **Pay attention to the direction in which the metal chips fly when sawing. The chips are hot and may cause fires or lead to burning and cutting injuries.**
- s) **Children must be instructed not to play with the power tool.**
- t) **The power tool is not intended for use by children, by debilitated persons or those who have received no instruction or training.**
- u) **Dust from materials such as paint or coatings containing lead, mineral materials and metals may present a health hazard. Contact with or inhalation of the dust may cause allergic reactions and/or respiratory diseases among operators or bystanders. Certain dusts are considered to be carcinogenic (cancer-causing), especially in conjunction with other substances (chromate). Material containing asbestos may be worked on only by specialists. Ensure that the workplace is well ventilated. The use of a dust mask of filter class P2 is recommended. Follow national requirements for the materials you want to work with.**

5.3.2 Power tool use and care

- Secure the workpiece. Use clamps or a vice to secure the workpiece.** The workpiece is thus held more securely than by hand and both hands remain free to operate the power tool.
- Check that the insert tools used are compatible with the chuck system and that they are secured in the chuck correctly.**
- Take care to ensure that metal cuttings do not find their way into the tool or battery.**
- Empty the chip collector and clean the power tool before putting it away in the toolbox or other container for storage or transport.** Metal chips may otherwise fall out of the collector and find their way into the power tool, battery or charger, presenting a risk of damage or malfunction.

5.3.3 Electrical safety



Before beginning work, check the working area (e.g. using a metal detector) to ensure that no concealed electric cables or gas and water pipes are present. External metal parts of the power tool may become live, for example, when an electric cable is damaged accidentally. This presents a serious risk of electric shock.

5.3.4 Battery use and care

- Observe the special instructions applicable to the transport, storage and use of Li-ion batteries.**
- Do not expose batteries to high temperatures or fire.** This presents a risk of explosion.
- Do not disassemble, squash or incinerate batteries and do not subject them to temperatures over 80°C.** This presents a risk of fire, explosion or injury through contact with caustic substances.

- Use only batteries that are approved for use with the applicable tool or appliance.** Use of unapproved batteries or use of the batteries for areas of application for which they are not approved presents a risk of fire and explosion.
- Do not charge or continue to use damaged batteries (e.g. batteries with cracks, broken parts, bent or pushed-in and/or pulled-out contacts).**
- If the battery gets too hot to touch, this may indicate that it is faulty. **Place the tool in a location where it can be kept under observation, well away from flammable materials, and allow it to cool down. Contact Hilti Service after the battery has been allowed to cool.**

5.3.5 Work area

- Ensure that the workplace is well lit.**
- Ensure that the workplace is well ventilated.** Exposure to dust at a poorly ventilated workplace may result in damage to the health.

5.3.6 Personal protective equipment



The user and any other persons in the vicinity must wear suitable eye protection, a hard hat, ear protection, protective gloves and breathing protection while the tool is in use.

5.3.7 Safety precautions

Do not switch the power tool on if the saw blade, the blade guard or the pivoting guard are not fitted correctly.

6 Before use



6.1 Battery use and care

NOTE

Battery performance drops at low temperatures. Never use the battery until the cells become fully discharged. Change to the second battery as soon as a drop in performance is noticed. Recharge the battery immediately so that it is ready for reuse.

Store the battery in a cool, dry place. Never store the battery where it is exposed to the heat of the sun, on a radiator or behind glass, e.g. at a window. Batteries that

have reached the end of their life must be disposed of safely and correctly to avoid environmental pollution. Insert the battery in the corresponding charger.

6.2 Charging the battery



DANGER

Use exclusively the specified Hilti batteries and Hilti battery chargers listed under "Accessories".

DANGER

Ensure that the outer surfaces of the battery are clean and dry before inserting it in the corresponding charger. Read the operating instructions for the charger for further information about the charging procedure.

6.2.1 Charging a new battery for the first time

Charge the battery fully before using it for the first time.

6.2.2 Charging a previously used battery

Ensure that the outer surfaces of the battery are clean and dry before inserting it in the corresponding charger. Read the operating instructions for the charger for further information about the charging procedure.

Lithium-ion battery packs are ready to use at any time, even when only partially charged. Charging progress is indicated by the LED display (see charger operating instructions).

6.3 Fitting the battery**CAUTION**

Before fitting the battery, check that the power tool is switched off and the switch-on interlock is activated (not pressed). Use only the Hilti batteries approved for use with this power tool.

CAUTION

Before inserting the battery in the tool, check to ensure that the battery terminals and the contacts in the tool are free from foreign objects.

1. Push the battery into the power tool from the rear as far as it will go and until it is heard to engage with a double click.
2. **CAUTION** A falling battery may present a risk of injury to yourself and others. Check that the battery is seated securely in the power tool.

6.4 Removing the battery from the power tool

1. Press both release buttons and hold them in this position.
2. Pull the battery out of the power tool toward the rear.

6.5 Transport and storage of batteries**CAUTION**

Empty the chip collector and clean the power tool before putting it away in the toolbox or other container for storage or transport. Metal chips may otherwise fall out of the collector and find their way into the power tool, battery or charger, presenting a risk of damage or malfunction.

Pull the battery out of the locked position (working position) and move it into the first click-stop position (transport position).

If you disconnect a battery from the power tool for transport or storage, make sure that the battery contacts are not short-circuited. Remove loose metal items such as screws, nails, clamps, loose screwdriving bits, wires or metal cuttings and chips from the toolbox or transport container, or prevent these items from coming into contact with the battery.

Observe national and international transport regulations when shipping batteries (transportation by road, rail, sea or air).

7 Operation**NOTE**

If the blade has jammed, the tool will not restart by itself after pressure on it has been released. The switch-on interlock and the on/off button must be pressed again to restart.

NOTE

The chip collector must always be fitted when the tool is in use.

CAUTION

Wear protective gloves. The cutting edges of the saw blade and cut edges of the workpiece are sharp. These sharp edges present a risk of injury.

CAUTION

Wear protective glasses and a dust mask. The sawing operation swirls up dust and chips into the air. The dust and chips may be harmful to the eyes and respiratory system.

CAUTION

Wear ear protectors. The power tool and the sawing operation generate noise. Exposure to noise can cause loss of hearing.

CAUTION

Secure the workpiece. Use clamps or a vice to secure the workpiece. This will help to prevent vibration.

CAUTION

Do not saw off very narrow strips. Narrow strips may be caught by the blade and pulled in, causing jamming, or may be thrown out, presenting a risk of injury.

CAUTION

When sawing, take care to ensure that there are no flammable materials in the vicinity and that no hot metal cuttings fall onto highly flammable materials.

CAUTION

Do not use coolants or lubricants when sawing.

7.1 Changing the saw blade**CAUTION**

Wear protective gloves when changing insert tools. The tool, the clamping flange and the clamping screw get hot.

CAUTION

Check that the blade to be fitted complies with the technical requirements and that it is well sharpened. A sharp saw blade is an essential requirement for a perfect cut.

7.1.1 Removing the saw blade 2

1. Pull the battery out of the power tool.
2. Press the drive spindle lockbutton and hold it in this position.
3. Turn the saw blade clamping screw with the hex socket wrench until the locking pin engages fully.
4. Release the clamping screw by turning the wrench further clockwise.
5. Remove the clamping screw from the outer clamping flange.
6. Open the pivoting guard by swinging it to the side and then remove the saw blade.

7.1.2 Fitting the saw blade 3

1. Pull the battery out of the power tool.
2. Clean the mounting flange and the clamping flange.
3. Fit the mounting flange.
4. Open the pivoting guard.
5. **CAUTION Only use blades which are suitable for this saw. Observe the direction-of-rotation arrow on the saw blade.**
Fit the new saw blade.
6. Fit the outer clamping flange.
7. Press the drive spindle lockbutton.
8. Fasten the clamping flange with the clamping screw by turning it anti-clockwise.
9. Before using the power tool, check that the saw blade is securely attached.

7.2 Adjusting the cutting depth 4

The cutting depth can be infinitely adjusted between 0 and 57 mm.

1. Pull the battery out of the power tool.
2. Place the power tool on a supporting surface.
3. Release the cutting depth adjustment clamping lever.
4. Lift the power tool in a scissor movement and set the desired cutting depth by closing the clamping lever.

7.3 Sawing along a line

The position of the saw blade is indicated by the mark on the base plate. This allows accurate cuts to be made. The edge of the line indicator corresponds to the inside of the saw blade. The viewing window provides a better view of the cutting line and thus helps ensure a more accurate cut.

1. Secure the workpiece to prevent movement.
2. Position the workpiece so that the saw blade is free to rotate beneath it.
3. Check to ensure that the on / off switch on the power tool is in the "off" position.
4. Fit the battery into the power tool.
5. Position the forward section of the saw's base plate on the workpiece but do not bring the blade into contact with the workpiece.
6. If the switch-on interlock has been pressed, switch the power tool on by pressing the on/off button.
7. Guide the saw along the cutting line on the workpiece at a suitable speed.

7.4 Sawing using the rip fence (accessory)

Use of the single arm rip fence allows precise cuts to be made along the edge of the workpiece, or strips of even width to be cut.

The rip fence can be fitted on either side of the base plate.

7.5 Fitting / adjusting the parallel guide (rip fence) 5

1. Remove the battery from the power tool.
2. Press the clamp together.
3. Push the parallel guide (rip fence) into the base plate as far as you wish.
4. Release the clamp when the parallel guide is in the desired position.

7.6 Emptying the chip collector 6**CAUTION**

Wear protective gloves when emptying the chip collector. The metal chips are sharp-edged and may be hot.

CAUTION

Empty the chip collector and clean the power tool before putting it away in the toolbox or other container for storage or transport. Metal chips may otherwise fall out of the collector and find their way into the power tool, battery or charger, presenting a risk of damage or malfunction.

When the power tool is in use you can check with the aid of the viewing window whether the collector is full.

1. Remove the battery from the tool.
2. Pull the chip collector away from the tool to the rear.

3. Swing the two halves of the chip collector apart and empty out its contents.
4. Push the chip collector onto the guard until it engages in position.

7.7 Procedure if the chip / dust channel is blocked

1. Remove the battery from the tool.
2. Remove the chip collector.
3. Clean the chip / dust channel.
4. Check that moving parts on the power tool are working properly and not jamming. Check also whether parts are broken or damaged in such a way that may cause the power tool to malfunction.

8 Care and maintenance**CAUTION**

Before beginning cleaning, remove the battery from the power tool in order to prevent unintentional starting.

8.1 Care of insert tools

Clean off dirt and dust deposits adhering to the insert tools and protect them from corrosion by wiping the insert tools from time to time with an oil-soaked rag.

8.2 Care of the power tool**CAUTION**

Keep the power tool, especially its grip surfaces, clean and free from oil and grease. Do not use cleaning agents which contain silicone.

The outer casing of the power tool is made from impact-resistant plastic. Sections of the grip are made from a synthetic rubber material.

Never operate the power tool when the ventilation slots are blocked. Clean the ventilation slots carefully using a dry brush. Do not permit foreign objects to enter the interior of the power tool. Clean the outside of the power tool at regular intervals with a slightly damp cloth. Do not use a spray, steam pressure cleaning equipment or running water for cleaning. This may negatively affect the electrical safety of the power tool.

8.3 Care of the Li-ion battery

Avoid ingress of moisture.

Charge the battery fully before using it for the first time. In order to achieve maximum battery life, stop discharging the battery as soon as a significant drop in battery performance is noticed.

NOTE

If use continues, further battery discharge will be stopped automatically before the battery cells suffer damage.

Charge the battery using an approved charger from Hilti designed for use with Li-ion batteries.

NOTE

- A conditioning charge (as is required with NiCd or NiMH batteries) is not necessary.

- Interruption of the charging procedure has no negative effect on battery life.
- Charging can be started at any time with no negative effect on battery life. There is no memory effect (as with NiCd or NiMH batteries).
- For best results, batteries should be stored fully charged in a cool dry place. Storing the battery in places subject to high ambient temperatures (e.g. at a window) has an adverse effect on battery life and increases the rate of self-discharge.
- If the battery no longer reaches full charge, it may have lost capacity due to aging or overstressing. It is still possible to work with this battery. You should, however, soon replace the battery with a new one.

8.4 Cleaning the safety devices

1. Remove the saw blade before cleaning the safety devices.
2. Clean the safety devices carefully with a dry brush.
3. Use a suitable tool to remove deposits or wood chips from the inside surfaces of the safety devices.
4. Fit the saw blade.

8.5 Maintenance**WARNING**

Repairs to the electrical section of the power tool may be carried out only by trained electrical specialists.

Check all external parts of the power tool for damage at regular intervals and check that all controls operate faultlessly. Do not operate the power tool if parts are damaged or when the controls do not function faultlessly. Have the power tool repaired by Hilti Service.

8.6 Checking the power tool after care and maintenance

After carrying out care and maintenance work on the power tool, check that all protective and safety devices are fitted and that they function faultlessly.

To check the pivoting guard, open the guard fully by moving the guard operating lever.

The pivoting guard must close quickly and completely when the guard operating lever is released.

9 Troubleshooting

en

Fault	Possible cause	Remedy
The power tool does not run.	The battery is discharged or fitted incorrectly.	The battery must be heard to engage with a double click or, respectively, needs to be charged.
	Electrical fault.	Remove the battery from the power tool and contact Hilti Service.
	The battery is discharged/hot.	Deep discharge prevention / the electronics switch off. Insert the battery in the charger or allow it to cool down.
The on / off button can not be pressed, i.e. the button is locked.	Not a fault (safety function).	Press the switch-on interlock.
Running speed suddenly drops considerably.	The saw blade jams.	Keep the saw blade running straight.
Chips are not transported into the chip collector and thus fall onto the base plate.	The chip collector is full or the chip deflector is blocked.	Empty the chip collector and/or clean the chip ejector channel.
The saw blade stalls.	Saw advance pressure is too high.	Reduce advance pressure and restart the saw.
The tool doesn't work and all 4 LEDs blink.	The power tool has been overloaded.	Release the control switch and press it again.
	The overheating prevention cut-out has been activated.	Allow the power tool to cool down. Clean the ventilation slots.
The power tool doesn't run and 1 LED blinks.	The battery is discharged.	Change the battery and recharge the discharged battery.
	The battery is too hot or too cold.	Bring the battery to the recommended working temperature.
The battery runs down more quickly than usual.	Battery condition is not optimal.	Have battery condition diagnosed by Hilti Service or replace with a new battery.
The battery does not engage with an audible double click.	The retaining lugs on the battery are dirty.	Clean the retaining lugs and check that the battery engages securely. Contact Hilti Service if the problem persists.
The power tool or the battery becomes very warm.	Electrical fault.	Switch the power tool off immediately, remove the battery and contact Hilti Service.
	The power tool has been overloaded (application limits exceeded).	Use the right power tool for the job (don't use a low-powered tool for heavy work).

10 Disposal

CAUTION

Improper disposal of the equipment may have serious consequences: the burning of plastic components generates toxic fumes which may present a health hazard. Batteries may explode if damaged or exposed to very high temperatures, causing poisoning, burns, acid burns or environmental pollution. Careless disposal may permit unauthorized and improper use of the equipment. This may result in serious personal injury, injury to third parties and pollution of the environment.

CAUTION

Dispose of defective batteries without delay. Keep them out of reach of children. Do not attempt to open or dismantle batteries and do not dispose of them by incineration.

CAUTION

Dispose of the batteries in accordance with national regulations or return them to Hilti.



Most of the materials from which Hilti power tools or appliances are manufactured can be recycled. The materials must be correctly separated before they can be recycled. In many countries, Hilti has already made arrangements for taking back your old power tools or appliances for recycling. Please ask your Hilti customer service department or Hilti representative for further information.

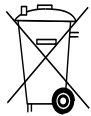

For EC countries only

Disposal of electric tools together with household waste is not permissible.

In observance of the European Directive on waste electrical and electronic equipment and its implementation in accordance with national law, electrical appliances that have reached the end of their life must be collected separately and returned to an environmentally compatible recycling facility.

11 Manufacturer's warranty - tools

Please contact your local Hilti representative if you have questions about the warranty conditions.

12 EC declaration of conformity (original)

Designation:	Cordless circular saw
Type:	SCM 22-A
Generation:	01
Year of design:	2011

We declare, on our sole responsibility, that this product complies with the following directives and standards: 2006/42/EC, 2004/108/EC, 2006/66/EC, 2011/65/EU, EN 60745-1, EN 60745-2-5, EN ISO 12100.

Hilti Corporation, Feldkircherstrasse 100,
FL-9494 Schaan

Handwritten signature of Jan Doongaji.

Jan Doongaji
Executive Vice President

Business Unit Power Tools &
Accessories
12/2011

Handwritten signature of Paolo Luccini.

Paolo Luccini
Head of BA Quality and
Process Management
Business Area Electric
Tools & Accessories
12/2011

Technical documentation filed at:

Hilti Entwicklungsgesellschaft mbH
Zulassung Elektrowerkzeuge
Hiltistrasse 6
86916 Kaufering
Deutschland



Hilti Corporation
LI-9494 Schaan
Tel.: +423/234 21 11
Fax: +423/234 29 65
www.hilti.com

Hilti = registered trademark of Hilti Corp., Schaan
W 4082 | 0214 | 00-Pos. 8 | 1
Printed in China © 2014
Right of technical and programme changes reserved S. E. & O.

2033298 / A6

