

HILTI

VC 20-U
VC 20-UL
VC 20-UM
VC 20-UME
VC 40-U
VC 40-UL
VC 40-UM
VC 40-UME

Original operating instructions
Mode d'emploi original
Oryginalna instrukcja obsługi
Originální návod k obsluze
Pôvodný návod na obsluhu
オリジナル取扱説明書

en
fr
pl
cs
sk
ja



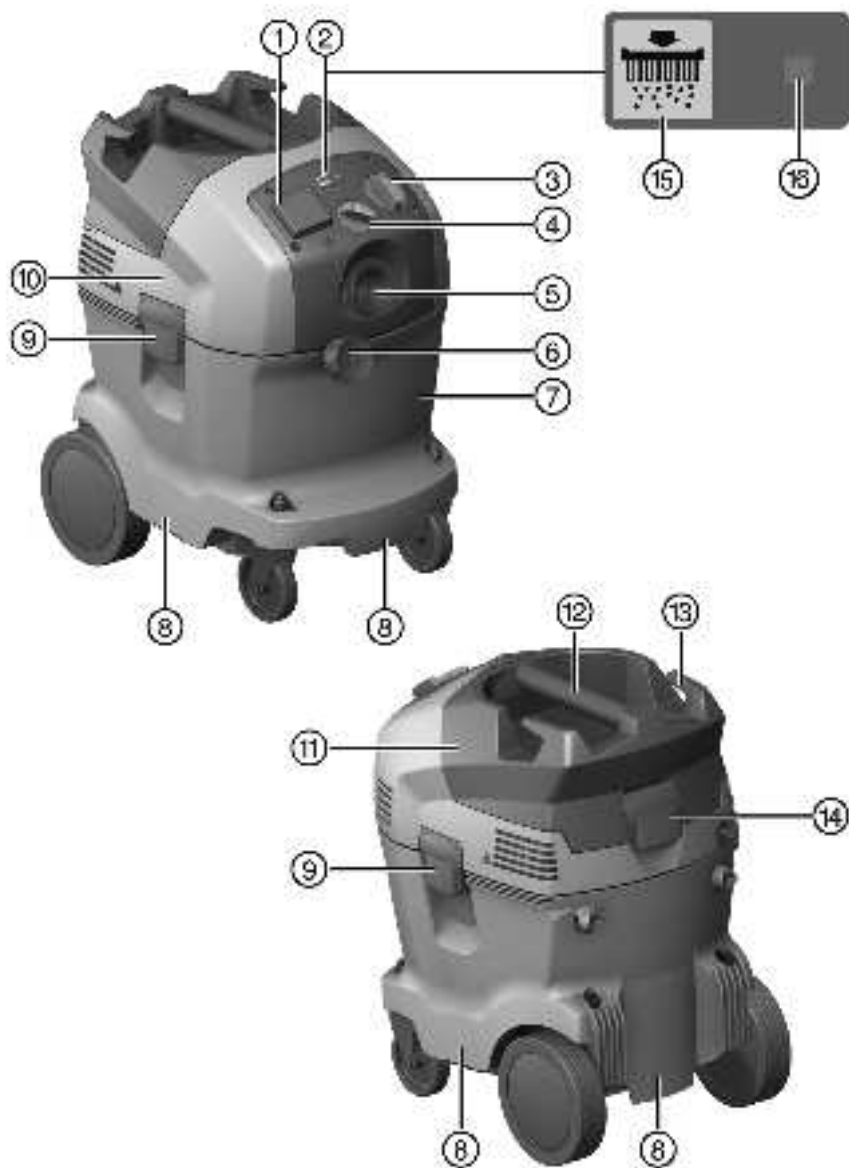

2



3



4



5





1 Information about the documentation

1.1 Conventions

1.1.1 Warning signs

The following warning signs are used:

	General warning
	Warning: hot surface



1.1.2 Prohibition signs

The following prohibition signs are used:

	Transport by crane is not permissible.
---	--

1.1.3 Symbols

The following symbols are used:

	Read the operating instructions before use.
	Instructions for use and other useful information

1.1.4 Typographical emphasis

The following typographical features are used in this technical documentation:

i	These numbers refer to the corresponding illustrations.
1	The numbering in the illustrations reflects the order of the work steps and may deviate from the numbering in the text.

1.2 On the appliance

VC 20-UL
VC 40-UL



WARNING: This unit contains hazardous dust. Emptying and maintenance, including the removal of the dust bag, may only be carried out by someone who is familiar with the unit and wearing suitable protective gear. Do not switch on until the complete filter system has been installed.

VC 20-UM
VC 20-UME
VC 40-UM
VC 40-UME



WARNING: This unit contains hazardous dust. Emptying and maintenance, including the removal of the dust bag, may be carried out only by well-informed persons wearing suitable protective gear. Do not

switch on the unit until the complete filter system has been installed and the function of the volume-flow control has been tested.

1.3 Operating instructions

- ▶ **It is essential that the operating instructions are read before initial operation.**
- ▶ **Always keep these operating instructions together with the appliance.**
- ▶ **Ensure that the operating instructions are with the appliance when it is given to other persons.**

Changes and errors excepted.

1.4 Product information

The type designation and serial number are printed on the type identification plate.

- ▶ Make a note of this data in the following table and always refer to it when making an enquiry to your Hilti representative or Hilti Service Center.

Product information

Type:	
Generation:	02
Serial no.:	

2 Safety

2.1 Warnings

The purpose of warnings

Warnings alert persons to hazards that occur when handling or using the product.

Description of the key words used

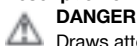

DANGER
Draws attention to imminent danger that will lead to serious personal injury or fatality.



WARNING
Draws attention to a potentially dangerous situation that could lead to serious personal injury or fatality.



CAUTION
Draws attention to a potentially dangerous situation that could lead to slight personal injury or damage to the equipment or other property.

2.2 Safety instructions

2.2.1 General safety instructions

In addition to the safety instructions given in the various sections of these operating instructions, the following points must be strictly observed at all times.

- ▶ **Read all the instructions.** Failure to follow all the instructions listed below may result in electric shock, fire and/or serious injury.
- ▶ **If the appliance is used in conjunction with an electric tool, read and follow the operating instructions for the electric tool and all the warnings.**
- ▶ **Modification of the appliance is not permitted.**
- ▶ **Use the right appliance for the job. Do not use the appliance for purposes for which it was not intended. Use it only as directed and when in faultless condition.**
- ▶ **Before beginning work with the appliance, find out how to operate it correctly and about any hazards associated with the materials it will be picking up and how these materials can be disposed of.**
- ▶ **Take the influences of the surrounding area into account. Do not use the appliance where there is a risk of fire or explosion.**
- ▶ **The appliance may only be used by persons who are familiar with it, have been trained on how to use it safely and who understand the resulting hazards. The appliance is not intended for use by children.**
- ▶ **Store appliances in a secure place when not in use. When not in use, appliances must be stored in a dry, high place or locked away out of reach of children.**

2.2.2 Personal safety

- ▶ **Stay alert, watch what you are doing and use common sense when working with the product. Do not use the vacuum cleaner while you are tired or under the influence of drugs, alcohol or medication.** A moment of inattention while operating the appliance may result in serious personal injury.
- ▶ **The user and any other persons in the vicinity must wear suitable eye protection, a hard hat, ear protection, protective gloves, safety footwear and breathing protection while the appliance is in use or while maintenance work on it is being carried out.**
- ▶ **Engage the wheel brakes so that the vacuum cleaner stands securely.** If the wheel brakes are disengaged the vacuum cleaner may run away out of control.
- ▶ **If devices are provided for the connection of dust extraction and collection facilities, ensure these are connected and properly used.** Use of a vacuum cleaner can reduce dust-related hazards.

2.2.3 Use and care of the appliance

- ▶ **Never leave the appliance unattended.**
- ▶ **Do not deactivate the filter cleaning system when picking up hazardous dusts, especially when the appliance is used in conjunction with electric tools that generate dust.**
- ▶ **Protect the appliance from frost.**
- ▶ **Clean the water level limiting device regularly with a brush, in accordance with the instructions, and check it for signs of damage.**
- ▶ **When fitting the top section of the vacuum cleaner, take care to avoid pinching your fingers or damaging the supply cord.** This presents a risk of injury or damage.
- ▶ **Check the appliance and its accessories for any damage. Guards, safety devices and any slightly damaged parts must be checked carefully to ensure that they function faultlessly and as intended. Check that moving parts function faultlessly, without sticking, and that no parts are damaged. In order to ensure faultless operation of the appliance, all parts must be fitted correctly and must meet the necessary requirements.**
- ▶ **Have the appliance serviced by a qualified repair person using only genuine Hilti spare parts.** The safety of the appliance can thus be maintained.
- ▶ **Always unplug the supply cord from the power outlet when the appliance is not in use (during breaks), before cleaning and maintenance and before changing the filter or accessories.** This preventive safety measure reduces the risk of starting the appliance accidentally.
- ▶ **Never pull the vacuum cleaner by the supply cord to a new working position. Do not run the wheels of the vacuum cleaner over the supply cord.**
- ▶ **Do not transport the appliance by crane.**

VC 20-UM
VC 20-UME
VC 40-UM
VC 40-UME

- ▶ **Close the hose inlet socket with the cap before transporting the appliance and when it is not in use.**

2.2.4 Electrical safety

- ▶ **The plug on the supply cord of the appliance must match the outlet. Do not change the plug in any way. Do not use adapter plugs with earthed (grounded) appliances.** Unmodified plugs and matching outlets reduce risk of electric shock.
- ▶ **Insert the plug in a suitable earthed/grounded power outlet which has been correctly and safely installed and is in compliance with local regulations. If you are in doubt about the effectiveness of the power outlet's earth/ground connection, have it checked by a qualified specialist.**
- ▶ **Avoid body contact with earthed or grounded surfaces such as pipes, radiators, cookers, stoves and refrigerators.** There is an increased risk of electric shock if your body is grounded.
- ▶ **Do not expose the appliance to rain or wet conditions.** Water entering an electric appliance will increase the risk of electric shock.
- ▶ **Check to ensure that the supply cord does not lie in a puddle of water.**
- ▶ **Check the appliance's supply cord at regular intervals and have it replaced by Hilti Service if damage is found. Check extension cords at regular intervals and replace them if found to be damaged.**
- ▶ **Do not touch the supply cord or extension cord if they are damaged while working. Disconnect the supply cord plug from the power outlet.** Damaged supply cords or extension cords present a risk of electric shock.

- ▶ The electric supply cord may be replaced only with a cord of the type specified in the operating instructions.
- ▶ **Do not abuse the cord. Never use the cord for carrying, pulling or unplugging the appliance. Keep the cord away from heat, oil, sharp edges or moving parts.** Damaged or entangled cords increase the risk of electric shock.
- ▶ **When operating an electric appliance outdoors, use only extension cords of a type suitable for outdoor use.** Use of an extension cord suitable for outdoor use reduces the risk of electric shock.
- ▶ **In the event of an interruption in the electric supply, switch the appliance off and unplug it from the power outlet.**
- ▶ **Use the electric tool power outlet only for the purposes described in the operating instructions.**
- ▶ **Never operate the appliance when it is dirty or wet.** Dust (especially dust from conductive materials) or dampness adhering to the surface of the appliance may, under unfavorable conditions, lead to electric shock. **Dirty or dusty appliances should thus be checked by Hilti Service at regular intervals, especially if used frequently for working on conductive materials.**

2.2.5 Workplace

- ▶ **Ensure that the workplace is well lit.**
- ▶ **Ensure that the workplace is well ventilated.** Exposure to dust at a poorly ventilated workplace may result in damage to the health.
- ▶ **Keep the workplace tidy. Objects which could cause injury should be removed from the working area.** Untidiness at the workplace can lead to accidents.
- ▶ **Do not operate the appliance in explosive atmospheres, such as in the presence of flammable liquids, gases or dust.** Electric appliances cause sparks which may ignite the dust or fumes.
- ▶ **Use extra care when working on stairs.**

2.2.6 The material picked up

- ▶ **Do not use the appliance to pick up flammable or explosive dusts (magnesium or aluminum dust etc.) or dusts that present a health hazard. Do not use the appliance to pick up materials with a temperature of over 60 °C (e.g. glowing cigarettes, hot ash).**
- ▶ **Do not use the appliance to pick up flammable, explosive or aggressive liquids (coolants and lubricants, gasoline, solvents, acids (pH < 5), alkalies (pH > 12.5), etc.).**
- ▶ **Switch the appliance off immediately if foam or liquids escape from it.**
- ▶ **Wear protective gloves when using the vacuum cleaner to pick up hot materials up to a temperature of 60 °C.**
- ▶ **When working with mineral drilling slurry, wear protective clothing and avoid skin contact with the slurry (pH > 9: caustic).**
- ▶ **Avoid contact with alkaline or acidic liquids. If contact accidentally occurs, rinse with water. In the event of the liquid coming into contact with the eyes, rinse the eyes with plenty of water and consult a doctor.**

VC 20-UL
VC 40-UL

- ▶ A Dust Class L appliance is suitable for picking up dry, non-flammable dusts, liquids, wood chips and hazardous dusts with an exposure limit value of > 1 mg/m³. **The appliance must be equipped with a suitable filter corresponding to the hazard classification of the dusts to be picked up.**

VC 20-UM
VC 20-UME
VC 40-UM
VC 40-UME

- ▶ A Dust Class M appliance is suitable for picking up dry, non-flammable dusts, liquids, wood chips and hazardous dusts with an exposure limit value of ≥ 0.1 mg/m³. **The appliance must be equipped with a suitable filter corresponding to the hazard classification of the dusts to be picked up.**

3 Description

3.1 Overview of the product 1

- | | | | |
|---|----------------------------|---|----------------|
| ① | Electric tool power outlet | ③ | Control switch |
| ② | Automatic filter cleaning | | |

- | | | | |
|---|--|---|---|
| ④ | Hose diameter setting (VC 20-UM OR VC 20-UME OR VC 40-UM OR VC 40-UME) | ⑩ | Vacuum cleaner top section |
| ⑤ | Hose socket | ⑪ | Filter cover |
| ⑥ | Cap for hose socket (VC 20-UM OR VC 20-UME OR VC 40-UM OR VC 40-UME) | ⑫ | Grip |
| ⑦ | Waste material container | ⑬ | Supply cord hook |
| ⑧ | Grip recess | ⑭ | Catch for filter cover |
| ⑨ | Catch | ⑮ | "Filter cleaning ON/OFF" button |
| | | ⑯ | Automatic filter cleaning system status indicator |

3.2 Use as directed

The products described here are industrial vacuum cleaners designed for universal, commercial use. They can be used for wet or dry applications.

Hilti products are designed for professional use and may be operated, serviced and maintained only by trained, authorized personnel. The product and its ancillary equipment may present hazards when used incorrectly by untrained personnel or when used not as directed.

Use of the product to clean down persons or animals is not permissible. Underwater use is not permissible.

- ▶ Before beginning work with the product, find out how to operate it correctly and about any hazards associated with the materials you will be working with and how these materials can be disposed of safely.
- ▶ Do not use the product for continuous, stationary operation in automatic or semi-automatic systems.
- ▶ To reduce the risk of injury, use only genuine **Hilti** tools and accessories.
- ▶ Use an antistatic suction hose in order to avoid electrostatic effects.
- ▶ Do not pick up objects or materials that could cause injury by piercing through the dust bag (e.g. pointed or sharp objects).
- ▶ Do not stand on the product (do not use it as a substitute for a ladder).

This product is suitable for the following applications in commercial use:

- Collecting large quantities of dust from **Hilti** diamond grinders, diamond cutters, rotary hammers and core drilling machines using dry-cutting core bits.
- Picking up drilling slurry (mineral materials) with **Hilti** diamond core bits or **Hilti** diamond saws and liquids up to a temperature of < 60 °C (140 °F).
- Picking up oil or liquid substances with a temperature of up to < 60 °C (140 °F).
- Wet and/or dry cleaning of wall and floor surfaces.

Additional use for the following types:

VC 20-UL
VC 40-UL

This product is suitable for the following applications:

- Picking up dry, non-flammable dusts, liquids, wood chips and hazardous dusts with an exposure limit value of > 1 mg/m³ (Dust Class L).

VC 20-UM
VC 20-UME
VC 40-UM
VC 40-UME

This product is suitable for the following applications:

- Picking up dry, non-flammable dusts, liquids, wood chips and hazardous dusts with an exposure limit value of ≥ 0.1 mg/m³ (Dust Class M).



Note

When picking up dusts with an exposure limit value, steps must be taken to ensure adequate air exchange in the room if the exhaust air from the appliance is released into the room.

Only hazardous substances in accordance with IEC 60335-2-69 (Class L/M) may be picked up using the appropriate vacuum cleaner. Picking up any other hazardous substances is not permissible.

Picking up oil or liquids with a temperature of ≥ 60 °C (140 °F) is not permissible.

VC 20-U
VC 40-U



WARNING

Health hazards The VC 20-U and VC 40-U models are not suitable for picking up dust which is hazardous to health.

- ▶ Do not use the VC 20-U or VC 40-U models to pick up dust which is hazardous to health.

3.3 Possible misuse

- Do not operate the industrial vacuum cleaner when it is laid on its side.
- Do not use the industrial vacuum cleaner to pick up substances that present a risk of explosion, glowing, burning or flammable substances or aggressive dusts (e.g. magnesium or aluminum dust, etc.) (exception: wood chips or shavings).
- Do not use the industrial vacuum cleaner to pick up flammable liquids (e.g. gasoline, solvents, coolants and lubricants, etc.).
- Working with materials hazardous to health (e.g. asbestos) is not permissible.

3.4 Items supplied

Wet/dry vacuum cleaner including filter element, suction hose complete with rotary connector (at the vacuum cleaner end) and accessory nozzle connector, PE VC 20/40 plastic dust bag, operating instructions.



Note

To help ensure safe and reliable operation, use only genuine Hilti spare parts and consumables. Spare parts, consumables and accessories approved by us for use with the product can be found at your local **Hilti Center** or online at: **www.hilti.com**

3.5 Hose diameter setting

VC 20-UM
 VC 20-UME
 VC 40-UM
 VC 40-UME

In order to ensure that the warning tone is triggered correctly, the hose diameter setting must be set correctly to the diameter of the suction hose used.

3.6 Warning tone

VC 20-UM
 VC 20-UME
 VC 40-UM
 VC 40-UME

An warning tone is emitted if the air speed in the suction hose drops below 20 m/s.

3.7 Automatic filter cleaning

The vacuum cleaner is equipped with an automatic filter cleaning system that removes most of the dust adhering to the filter element.

The filter cleaning system can be switched off by pressing the “Automatic filter cleaning ON/OFF” button and switched back on by pressing the button again.

Status	Meaning
LED lights.	<ul style="list-style-type: none"> • The filter cleaning system is active.
LED doesn't light.	<ul style="list-style-type: none"> • The filter cleaning system is not active.

The filter cleaning system is activated automatically each time the vacuum cleaner is switched on. The filter element is cleaned automatically by a blast of air (a pulsating noise is heard).



Note

In order to achieve continuously high suction performance in system applications (especially grinding and sanding, cutting and slitting) or when picking up large quantities of dust, the filter cleaning system must be active.

The filter cleaning system functions only when a suction hose is connected.

3.8 Instructions for use

Accessories and how they are used

Accessories	Type of use
PE VC 20 synthetic dust bag (203854)	Working with mineral materials, wet and dry
PE VC 40 synthetic dust bag (203852)	Working with mineral materials, wet and dry
VC 20 paper dust bag (203858)	Working with wood
VC 40 paper dust bag (203856)	Working with wood
VC 20/40 dry filter (2121386)	Dry
VC 20/40 universal filter (2121387)	Universal use, wet and dry
VC 20/40 performance filter (2121388)	Heavy use, wet and dry
Suction hose, 27 x 3.5 m AS	Wet and dry
Suction hose, 36 mm	Mainly wet, not for dust
Suction hose, 36 x 5 m AS	Wet and dry

VC 20-UM
VC 20-UME
VC 40-UM
VC 40-UME

- A plastic dust bag or paper dust bag must always be used. This is essential.

4 Technical data

4.1 Rated voltage



Note

When powered by a generator or transformer, the generator or transformer's power output must be at least twice the rated input power shown on the rating plate of the appliance. The operating voltage of the transformer or generator must always be within +5% and -15% of the rated voltage of the appliance.

Rated voltage	100 V	110 V	110 V	200 V
Rated power input	1200 W	1200 W	1100 W	950 W
Maximum load on built-in power outlet for electric tools (if fitted)		1600 W		
Mains connection (type)	VCTF 3 x 2.0 mm ²	A07 QQ-F 3 / 12 AWG	H07 BQ-F 3G 1.5 mm ²	VCTF 3 x 2.0 mm ²

Rated voltage	220 - 240 V	220 - 240 V (CH)	220 - 240 V (GB)	240 V (NZ)
Rated power input	1200 W	1200 W	1200 W	1200 W
Maximum load on built-in power outlet for electric tools (if fitted)	2400 W	1100 W	1800 W	1200 W
Mains connection (type)	H07 RN-F 3G 1.5 mm ²	H07 RN-F 3G 1.5 mm ²	H07 RN-F 3G 1.5 mm ²	H07 RN-F 3G 1.5 mm ²

4.2 Maximum volumetric flow rate and maximum vacuum

		VC 20-U	VC 40-U	VC 20-UL	VC 40-UL
Maximum volumetric flow rate (air)	950 W	55 ℓ/s	55 ℓ/s	•/•	•/•
	1100 W	61 ℓ/s	61 ℓ/s	•/•	•/•
	1200 W	61 ℓ/s	61 ℓ/s	•/•	•/•

		VC 20-U	VC 40-U	VC 20-UL	VC 40-UL
Maximum volumetric flow rate (air)	1100 W	•/•	•/•	135 m³/h	135 m³/h
	1200 W	•/•	•/•	145 m³/h	145 m³/h
Maximum vacuum	950 W	195 hPa	195 hPa	•/•	•/•
	1100 W	230 hPa	230 hPa	185 hPa	185 hPa
	1200 W	230 hPa	230 hPa	220 hPa	220 hPa

		VC 20-UM	VC 20-UME	VC 40-UM	VC 40-UME
Maximum volumetric flow rate (air)	950 W	•/•	•/•	•/•	•/•
	1100 W	•/•	•/•	•/•	•/•
	1200 W	•/•	•/•	•/•	•/•
Maximum volumetric flow rate (air)	1100 W	135 m³/h	135 m³/h	135 m³/h	135 m³/h
	1200 W	145 m³/h	145 m³/h	145 m³/h	145 m³/h
Maximum vacuum	950 W	•/•	•/•	•/•	•/•
	1100 W	185 hPa	•/•	185 hPa	185 hPa
	1200 W	220 hPa	220 hPa	220 hPa	220 hPa

4.3 Wet / dry vacuum cleaner

	VC 20	VC 40
AC frequency	50 Hz ... 60 Hz	50 Hz ... 60 Hz
Weight in accordance with EPTA procedure 01/2003	13 kg	14.7 kg
Dimensions	505 mm x 380 mm x 500 mm	505 mm x 380 mm x 610 mm
Container capacity	21 ℓ	36 ℓ
Effective dust capacity	23 kg	40 kg
Effective water capacity	13.5 ℓ	25 ℓ
Air temperature	-10 °C ... 40 °C	-10 °C ... 40 °C
Automatic filter cleaning, all	15 s	15 s
Protection class	I	I
Protection class	IP X4	IP X4

4.4 Noise and vibration information, measured in accordance with EN 60335-2-69

The following information applies to all VC 20 and VC 40 industrial vacuum cleaners.

Emission sound pressure level (L_{pA})	71 dB(A)
Uncertainty for the sound pressure level (K_{pA})	2.5 dB(A)
Vibration emission value	< 2.5 m/s ²
Uncertainty (K)	Is already taken into account in the vibration emission value

5 Before use



CAUTION

Risk of injury presented by the appliance running away out of control. The vacuum cleaner may run away out of control if the wheel brakes are not engaged.

- ▶ Engage the wheel brakes so that the vacuum cleaner stands securely.

5.1 Operating the appliance for the first time

1. Open the two catches.
2. Lift the vacuum cleaner top section away from the waste material container.
3. Remove the accessories and packaging from the waste material container.
4. Fit a suitable dust bag in accordance with the instructions.



Note

For picking up dusts with an exposure limit value of $> 1 \text{ mg/m}^3$, the Class L or Class M version may be used: Plastic dust bag for mineral dust or paper dust bag for wood chips.

For picking up dusts with an exposure limit value of $\geq 0.1 \text{ mg/m}^3$, the Class M version must be used: Plastic dust bag for mineral dust or paper dust bag for wood chips.

When used to pick up harmless dusts: plastic dust bag.

5. Fit the vacuum cleaner top section onto the waste material container and close the two catches.
6. Check to ensure that the vacuum cleaner top section is fitted correctly and secured.
7. Connect the suction hose to the appliance.

5.2 Fitting a paper dust bag for picking up wood chips 2

1. Open the two catches.
2. Lift the vacuum cleaner top section away from the waste material container.
3. Fit the new paper dust bag into the adapter and insert these in the waste material container.
4. Fit the vacuum cleaner top section onto the waste material container.
5. Close the two catches.
6. Check to ensure that the vacuum cleaner top section is fitted correctly and secured.
7. Connect the suction hose to the appliance.

5.3 Fitting a plastic dust bag

1. Open the two catches.
2. Lift the vacuum cleaner top section away from the waste material container.
3. Fit a new plastic dust bag (see instructions printed on it) in the waste material container.
4. Fit the vacuum cleaner top section onto the waste material container and close the two catches.

6 Operation



DANGER

Electrical hazards. Fatal or serious injury may result if the vacuum cleaner is not correctly connected to the electric supply.

- ▶ Connect the vacuum cleaner only to a properly earthed/grounded power source.



WARNING

Risk of injury. Damage to the filter system may allow harmful dust (health hazard) to escape.

- ▶ In an emergency (e.g. filter ruptured), switch the vacuum cleaner off, unplug the supply cord from the power outlet and have the vacuum cleaner checked by a trained and qualified person before further use.



CAUTION

Risk of injury presented by the appliance running away out of control. The vacuum cleaner may run away out of control if the wheel brakes are not engaged.

- ▶ Engage the wheel brakes so that the vacuum cleaner stands securely.

6.1 Using Class L or Class M vacuum cleaners

VC 20-UL
VC 20-UM
VC 20-UME
VC 40-UL
VC 40-UM
VC 40-UME



DANGER

Risk of injury. Class L and Class M vacuum cleaners contain dust that is hazardous to the health.

- ▶ Emptying and maintenance, including disposal of the dust collection container, may be carried out only by trained and qualified specialists. Wear the appropriate protective equipment.
- ▶ Before removing the vacuum cleaner from an area contaminated with hazardous substances, use the vacuum cleaner to clean off its own exterior, wipe it clean or place it in a sealed bag or container. As all parts of the appliance must be considered to be contaminated, suitable measures to avoid spreading the dust must be implemented before these parts are removed from the hazardous area.
- ▶ Never operate the vacuum cleaner without the complete filter system fitted.

6.2 Setting the hose diameter

VC 20-UM
VC 20-UME
VC 40-UM
VC 40-UME

1. When picking up dry, non flammable dust which has an exposure limit value, or when picking up wood chips or shavings, adjust the hose diameter setting switch to the correct diameter setting → Seite 6 for the suction hose used.
2. Set the switch to the smallest hose diameter if you are using the vacuum cleaner with a **Hilti** hollow drill bit system.

6.3 Operation without use of the electric tool power outlet

1. Check that the switch on the appliance is in the “OFF” position off before plugging the supply cord into a power outlet.
2. Plug the vacuum cleaner’s supply cord into the power outlet.
3. Turn the control switch to the “ON” position.

6.4 Operation with use of the electric tool power outlet



Note

The electric tool power outlet is to be used only for powering electric tools directly from the vacuum cleaner.

The operating instructions and safety instructions for the electric tool plugged into the electric tool power outlet on the vacuum cleaner must be observed.

1. Unplug the vacuum cleaner’s supply cord from the power outlet.
2. Check that the maximum power drawn by the electric tool is below the maximum permissible output of the electric tool power outlet on the vacuum cleaner (please refer to the “Technical data” section of the operating instructions and information printed on the electric tool power outlet).
3. Check to ensure that the electric tool is switched off before plugging its supply cord into the power outlet.
4. Plug the electric tool’s supply cord into the electric tool power outlet on the vacuum cleaner.
5. Plug the vacuum cleaner’s supply cord into the power outlet.
6. Turn the control switch to the “Auto” position.
7. Switch on the power tool.



Note

The vacuum cleaner will continue to run for a short time after switching off the electric tool in order to ensure that all dust is removed from the suction hose.

6.5 Picking up dry dust



Note

Before picking up dry dust, especially dust from mineral materials, always check to ensure that the correct dust bag is fitted in the container. The material picked up by the vacuum cleaner can then be disposed of cleanly and easily.



CAUTION

Risk of injury. Hazardous material that has been picked up may escape if a filter element is not used.

- ▶ Never use the appliance without a filter element.

- ▶ Check that the filter element is dry and that the correct type of dust bag is fitted.

6.6 Changing the paper dust bag



DANGER

Risk of injury. Sharp pointed objects may pierce through the dust bag.

- ▶ Check that no objects have pierced through the dust bag.

1. Disconnect the supply cord plug from the power outlet.
2. Open the two catches.
3. Lift the vacuum cleaner top section away from the waste material container.
4. Carefully release the mouth of the dust bag from the adapter.
5. Close the mouth of the dust bag with the slider.
6. Clean the waste material container with a cloth.
7. Fit a new paper dust bag in the waste material container.
8. Fit the vacuum cleaner top section onto the waste material container and close the two catches.

6.7 Changing a plastic dust bag

1. Disconnect the supply cord plug from the power outlet.
2. Open the two catches.
3. Lift the vacuum cleaner top section away from the waste material container.
4. Use a cable tie to close the plastic dust bag below the punched holes.
5. Remove the plastic dust bag.
6. Clean the waste material container with a cloth.
7. Fit a new plastic dust bag (see instructions printed on it) in the waste material container.
8. Fit the vacuum cleaner top section onto the waste material container and close the two catches.

6.8 Picking up liquids



CAUTION

Risk of injury. Hazardous material that has been picked up may escape if a filter element is not used.

- ▶ Never use the appliance without a filter element.

1. Check the container level monitoring system. → Seite 13
2. If possible, use a separate filter element for wet applications.



Note

The **Hilti** VC 20/40 universal (2121387) filter is recommended.

3. After picking up liquids, open the two catches.
4. Lift the vacuum cleaner top section away from the waste material container and place it on a level surface so that the filter element can dry.
5. Empty the waste material container and use a water hose to rinse it out. Use a brush to clean the electrodes and clean the filter element, after allowing it to dry, by wiping it off with your hand.
6. Allow the waste material container to dry.

6.9 After use of the vacuum cleaner

1. Switch off the electric tool.
2. Turn the vacuum cleaner control switch to the "OFF" position.
3. Unplug the vacuum cleaner's supply cord from the power outlet.
4. Coil up the supply cord and hang it on the hook.
5. Empty the container and clean the appliance by wiping it with a damp cloth.
6. Coil up the suction hose.
7. Store the vacuum cleaner in a secure, dry place where it is inaccessible to unauthorized users.

6.10 Emptying dry dust from the waste material container

1. Pull the plug out of the power outlet.
2. Lift the vacuum cleaner top section away from the waste material container and place it on a level surface.

VC 20-UM
VC 20-UME
VC 40-UM
VC 40-UME

- ▶ Remove the dust bag from the waste material container.

VC 20-U
VC 20-UL
VC 40-U
VC 40-UL

- ▶ Remove the dust bag from the waste material container or grip the container by the recess provided and empty it by tipping out the contents.
3. Fit the vacuum cleaner top section onto the waste material container and close the two catches.

6.11 Emptying the waste material container when no dust bag is fitted (picking up liquids)

1. Disconnect the supply cord plug from the power outlet.
2. Lift the vacuum cleaner top section away from the waste material container and place it on a level surface.
3. Grip the waste material container by the recess provided and empty it by tipping out the contents.
4. Clean the edge of the waste material container with a cloth.
5. Fit the vacuum cleaner top section onto the waste material container and close the two catches.

7 Care, maintenance, transport and storage

7.1 Care and maintenance of the appliance



WARNING

Electrical hazards. Improper repairs to electrical parts may lead to serious injuries.

- ▶ Electrical parts may be repaired only by trained electrical specialists.

- ▶ **Keep the appliance, especially its grip surfaces, clean and free from oil and grease. Do not use cleaning agents containing silicone.**
- ▶ Never operate the vacuum cleaner when the air vents are blocked. Clean the air vents carefully using a dry brush. Do not permit foreign objects to enter the interior of the appliance.
- ▶ Clean the outer surfaces of the appliance with a slightly damp cloth at regular intervals. Do not use a spray system, pressure jet washer or running water for cleaning as this may negatively affect the electrical safety of the appliance.

VC 20-UL
VC 20-UM
VC 20-UME
VC 40-UL
VC 40-UM
VC 40-UME

The appliance must be handled for cleaning and maintenance in a way that avoids exposing maintenance personnel and other persons to any hazards.

- ▶ Use filtered forced ventilation.

- ▶ Wear personal protective equipment.
- ▶ Clean the maintenance area in a way that prevents hazardous substances escaping into the surrounding environment.
- ▶ Vacuum off the outer surfaces of the appliance and wipe it clean or seal it in a suitable container, e.g. large plastic bag, before removing it from an area contaminated with hazardous substances. This will help to avoid distribution of the hazardous dust deposited on it.
- ▶ When maintenance or repairs are carried out, all contaminated parts which cannot be satisfactorily cleaned must be packed in impermeable bags and disposed of in compliance with the applicable disposal regulations.
- ▶ The appliance must be subjected to a technical inspection by **Hiti Service** or a trained person at least once a year to check, for example, for damage to the filter, air leakage, and to ensure correct operation of controlling devices.

7.2 Automatic filter cleaning



Note

Do not attempt to clean the filter element by knocking it against a hard object and do not use pointed instruments. This will reduce the life of the filter element.

Do not use compressed air to clean the filter element. This may cause tears in the filter material.

The condition of the filter element deteriorates with use.

- ▶ Replace the filter element at least every six months.
- ▶ However, if used intensively, the filter element should be replaced more often.

7.3 Changing the filter element 5

1. Disconnect the supply cord plug from the power outlet.
2. Open the filter cover catches.
3. Open the filter cover.
4. Carefully remove the filter element, gripping it at the areas provided in the holder.
5. Clean the sealing surface with a cloth.
6. Fit the new filter element.
7. Close the filter cover by flipping the cover catch forward.
8. Close the filter cover catch.

7.4 Checking the container level monitoring system

1. Engage the wheel brakes so that the vacuum cleaner stands securely.
2. Disconnect the supply cord plug from the power outlet.
3. Open the two catches.
4. Lift the vacuum cleaner top section away from the waste material container and place it on a level surface.
5. Check the cut-out contacts and clean them with a brush if necessary (if dirty).
6. Check the seal at the vacuum cleaner top section and clean it with a cloth if necessary.
7. Fit the vacuum cleaner top section onto the waste material container and close the two catches.

7.5 Checks after cleaning and maintenance

1. After cleaning or carrying out maintenance, check that the vacuum cleaner is assembled correctly and that it functions faultlessly.
2. Test each of the functions.

7.6 Transport

Do not carry the appliance when it is full of waste material.

The appliance may not be lifted directly by crane.

- ▶ When necessary, remove the power conditioner and any loose accessories from their holders or attachment points.
- ▶ Empty the appliance before carrying it to another location.
- ▶ Do not tip the appliance or transport it lying on its side after using it to pick up liquids.
- ▶ Use the tapered adapter to connect both ends of the hose together conveniently for transport.



DANGER

Risk of injury. Hazardous material that has been picked up may escape through the suction hose inlet socket.

- ▶ Close the hose inlet socket on a Class M vacuum cleaner with the cap provided before transportation and when the appliance is not in use.

7.7 Storage

- ▶ Store the vacuum cleaner in a secure, dry place where it is inaccessible to unauthorized users.

8 Troubleshooting

If the trouble you are experiencing isn't listed in this table or you are unable to remedy the problem by yourself, please contact **Hilti Service**.

Trouble or fault	Possible cause	Action to be taken
VC 20-UM VC 20-UME VC 40-UM VC 40-UME Warning tone (reduced suction performance)	The dust bag is full.	<ul style="list-style-type: none"> ▶ Change the paper dust bag. → Seite 11 ▶ Change the plastic dust bag. → Seite 11
	The filter element is clogged with dirt or dust.	<ul style="list-style-type: none"> ▶ If the automatic filter cleaning system is deactivated, activate it and allow the vacuum cleaner to run for 30 seconds. ▶ Change the filter element. → Seite 13
	The suction hose or dust hood on the electric tool is blocked.	▶ Clean the suction hose and the dust hood.
	The hose diameter setting is incorrect.	▶ Set the hose diameter.
Dust is blown out of the appliance.	The filter element is not fitted correctly.	▶ Fit the filter element again correctly.
	The filter element is damaged.	▶ Fit a new filter element.
The appliance switches itself off or on inadvertently or static electricity discharges through the user.	Electrostatic charge is not conducted away – the appliance is connected to an unearthed/ungrounded power outlet.	▶ Connect the appliance to an earthed/grounded power outlet and use an antistatic suction hose.
The appliance doesn't start or switches itself off after a short time.	The water level cut-out is activated.	▶ Clean the sensors and the area around the sensors with a brush.
The motor doesn't restart.	The mains circuit breaker has been tripped.	<ul style="list-style-type: none"> ▶ Reset the circuit breaker. ▶ Find the reason for the overload current if the circuit breaker trips again.
	The waste material container is full.	<ul style="list-style-type: none"> ▶ Switch the appliance off and empty the waste material container. ▶ Empty the waste material container. → Seite 12

Trouble or fault	Possible cause	Action to be taken
The motor doesn't restart.	The motor overheating protection cut-out has been activated.	<ul style="list-style-type: none"> ▶ Switch the appliance off and allow it to cool down for about 5 minutes. ▶ If the motor doesn't start, return the appliance to Hilti Service.
	The motor overheating protection cut-out switches the motor off repeatedly because the air vents are clogged.	<ul style="list-style-type: none"> ▶ Clean the air vents carefully using a dry brush.
The motor doesn't run when set to "AUTO".	The appliance is faulty or is not correctly plugged in.	<ul style="list-style-type: none"> ▶ Make sure that the supply cord plug is fully plugged in and check that the appliance functions correctly.
The automatic filter element cleaning system doesn't work.	No suction hose is connected.	<ul style="list-style-type: none"> ▶ Connect the suction hose.

9 Disposal

 Most of the materials from which **Hilti** products are manufactured can be recycled. The materials must be correctly separated before they can be recycled. In many countries, your old tools, machines or appliances can be returned to **Hilti** for recycling. Ask **Hilti Service** or your **Hilti** representative for further information.

In accordance with the European Directive on waste electrical and electronic equipment and its implementation in conformance with national law, electric tools or appliances that have reached the end of their life must be collected separately and returned to an environmentally compatible recycling facility.



- ▶ Do not dispose of electric appliances together with household waste.

Drilling slurry

Disposal of drilling slurry directly into rivers, lakes or the sewerage system without suitable pretreatment presents environmental problems.

- ▶ Ask the local public authorities for information about current regulations.

We recommend the following pretreatment:

- ▶ Collect the drilling slurry (for example, using a wet-type vacuum cleaner).
- ▶ Allow the drilling slurry to settle and dispose of the solid material at a construction waste disposal site (addition of a flocculent may accelerate the settling process).
- ▶ The remaining water (alkaline, pH value greater than 7) must be neutralized by the addition of an acidic neutralizing agent or diluted with a large volume of water before it is allowed to flow into the sewerage system.

Drilling dust

- ▶ Dispose of the drilling dust collected by the vacuum cleaner in accordance with the applicable national regulations.

10 Manufacturer's warranty

- ▶ Please contact your local **Hilti** representative if you have questions about the warranty conditions.

11 EC declaration of conformity

Manufacturer

Hilti Aktiengesellschaft
Feldkircherstrasse 100
9494 Schaan
Liechtenstein

We declare, on our sole responsibility, that this product complies with the following directives and standards.

Designation

Wet / dry vacuum cleaner

Type designation	VC 20-U
Generation	02
Year of design	2015
Type designation	VC 20-UL
Generation	02
Year of design	2015
Type designation	VC 20-UM
Generation	02
Year of design	2015
Type designation	VC 20-UME
Generation	02
Year of design	2015
Type designation	VC 40-U
Generation	02
Year of design	2015
Type designation	VC 40-UL
Generation	02
Year of design	2015
Type designation	VC 40-UM
Generation	02
Year of design	2015
Type designation	VC 40-UME
Generation	02
Year of design	2015

Applicable directives:

- 2006/42/EC
- 2004/108/EC (up to April 19, 2016)
- 2014/30/EU (as of April 20, 2016)
- 2011/65/EU

Applicable standards:

- EN 60335-1, EN 60335-2-69
- EN ISO 12100

Technical documentation filed at:

- Electric Tools Approval Department
Hilti Entwicklungsgesellschaft mbH
Hiltistraße 6
86916 Kaufering
Germany

Schaan, 06.2015

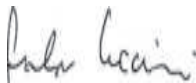

Paolo Luccini
(Head of BA Quality and Process Management /
Business Unit Electric Tools & Accessories)



Johannes Wilfried Huber
(Senior Vice President / Business Unit Diamond)

HILTI

Hilti Corporation

LT 9494 Schaan

Tel: +423 7234 21 11

Fax: +423 7234 20 66

www.hilti.com



2122258