

INTERCOOLER KIT INSTALLATION MANUAL



NAME OF PRODUCT	INTERCOOLER KIT
PART NUMBER	13001-AM007
APPLICATION	MITSUBISHI LANCER EVOLUTION X / CBA-CZ4A (USDM)
ENGINE	4B11
YEAR	2007/10 -
REMARKS	【ADVICE】 <ul style="list-style-type: none">• For optimal product performance, use with the factory piping or HKS Piping Kit (P/N 13002-AM003). If a non-HKS piping kit is used, fitment issues may occur.• Some modifications to factory parts are required in order to install this kit.• The following item is required:<ul style="list-style-type: none">• Power Steering Fluid (Mitsubishi ATF II)• Paint (to paint the cut portions) Body Color or Black

NOTICE

This manual assumes that you have and know how to use the tools and equipment necessary to safely perform service operations on your vehicle. This manual assumes that you are familiar with typical automotive systems and basic service and repair procedures. Do not attempt to carry out the operations shown in this manual unless these assumptions are correct. Always have access to a factory repair manual. To avoid injury, follow the safety precautions contained in the factory repair manual.

REVISION OF MANUAL

Rev. Number	Date	Details
3-3.01	2009/2	1 st Edition

Published in February, 2009 by HKS Co., Ltd. (Unauthorized reproduction is strictly prohibited.)

1. Necessary Modifications

Some modifications are necessary in order to install this product. Details are listed below.

<u>Description</u>	<u>Modification</u>	<u>Material</u>	<u>Diagram</u>
Power steering cooler pipe	Pipe shape/bracket shape	Aluminum	D3-1-2 D3-1-3
AC condenser	Removal of stopper/cut stopper/add stopper gaps in the bracket	Plastic/aluminum	D3-2-1 D3-2-2 D3-2-3
AC pipe	Pipe shape	Aluminum	D3-3-2
Headlight support upper panel	Cut bracket	Steel	D3-3-3
Reinforcement: Power steering pipe bracket Bracket Reinforcement	Disassemble rivet Cut a section Add gaps	Aluminum Steel Aluminum	D3-4-1 D3-4-4
Front bumper air guide duct	Cut off protruding section	Plastic	D3-4-2
Intercooler bracket (RH)	Cut bracket	Steel	D3-4-9
Front bumper air guide	Cut	Plastic	D4-4
Headlight support cover	Remove ribbed section	Plastic	D4-5

2. Removal of Factory Parts

Make sure to disconnect the negative terminal cable of the vehicle's battery prior to starting the installation procedure. Reference the vehicle's factory service manual when performing the installation procedure.

1. Remove the air cleaner duct. (D2-1)

NOTE: This part will be reused later.

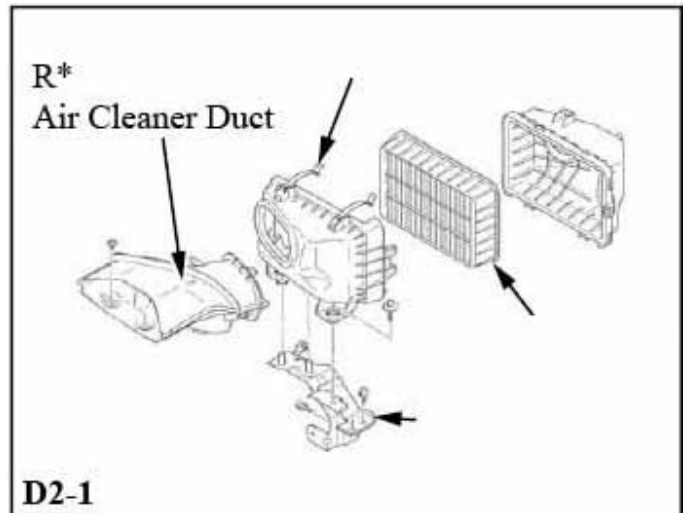

2. Remove the engine room under cover front A, engine room under cover front B, and engine room under cover center. (D2-2)

NOTE: These parts will be reused later.

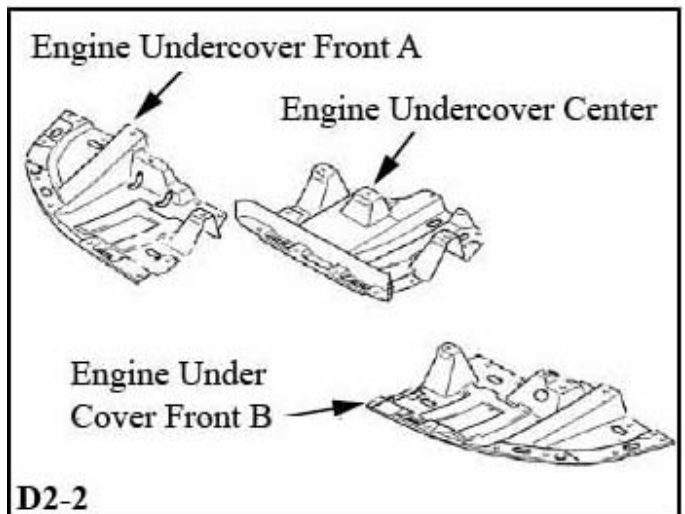

3. Remove the headlight support cover, front bumper assy, front bumper air guide center duct, and front bumper reinforcement. (D2-3)

NOTE: These parts will be reused later.

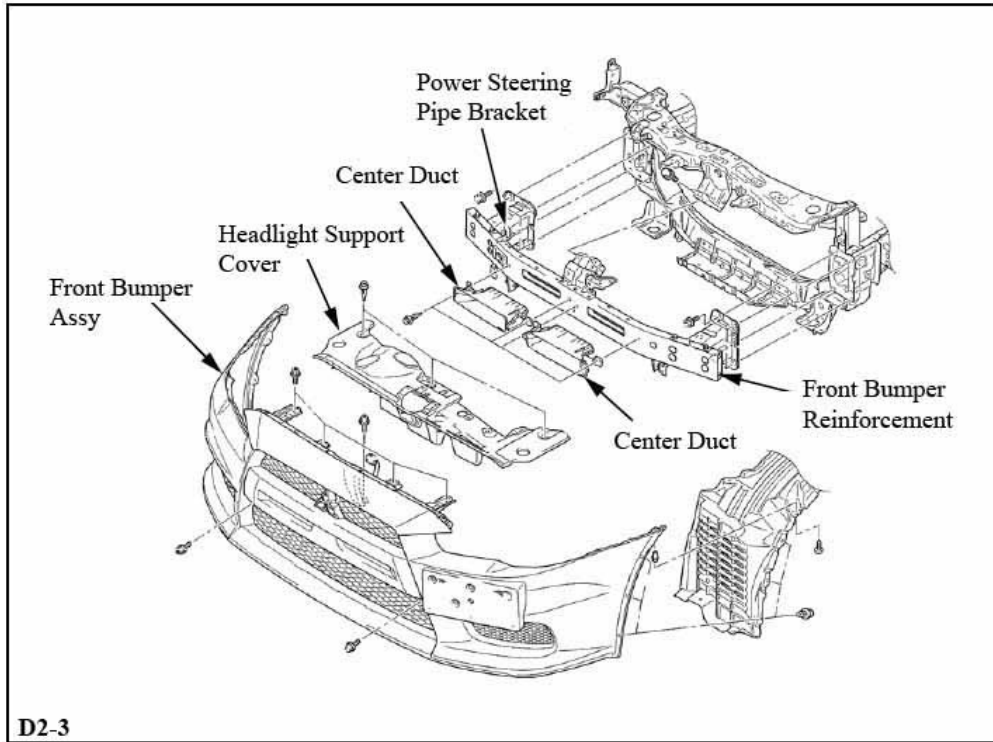

4. Remove intercooler pipe and hoses ①-②, and remove the intercooler core assy. (D2-4)

NOTE: The bolts and hose clamps will be reused later. Make sure no dirt/debris enters the hoses.

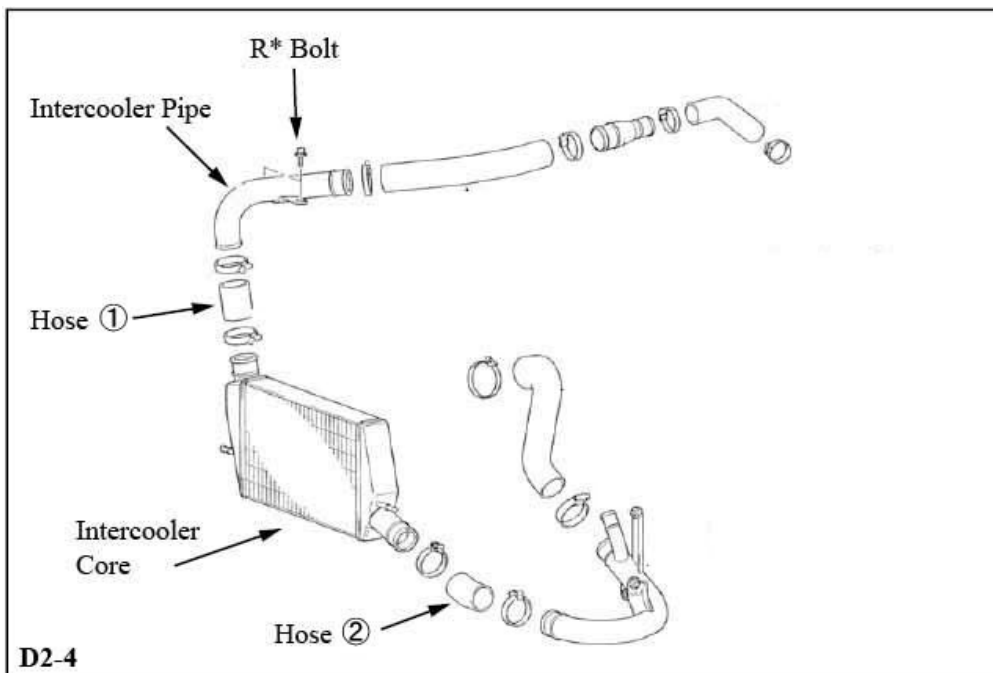

3. Installation of Kit Parts

3-1) Relocating the Power Steering Cooler Pipe

1. Cut the Oil Resistant Hose 10mm to length 480mm x 2.
 - Oil Resistant Hose 10mm (P13 x 1)
2. Cut the Corrugated Tube 15mm to length 250mm.
 - Corrugated Tube 15mm (P28 x 1)
3. Remove the power steering cooler pipe and hose from the power steering line. (D3-1-1)

NOTE: Prepare a drainage tub beforehand, as power steering fluid will drain from the line. Use a stopper on the line to minimize drain of power steering fluid. The hose clamps will be reused later.

4. Bend the power steering cooler pipe such that it does not come into contact with the front bumper assy. (D3-1-2)

5. Bend the power steering cooler pipe in the direction of the arrow shown in diagram D3-1-3, such that it does not come into contact with the AC condenser.

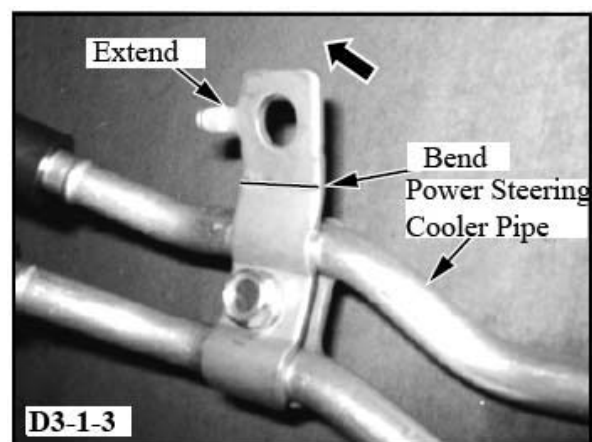
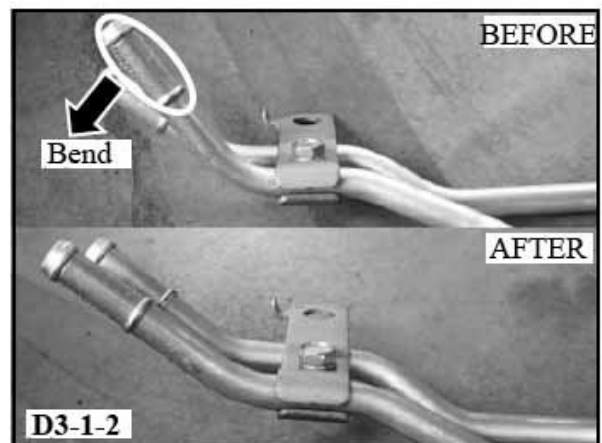
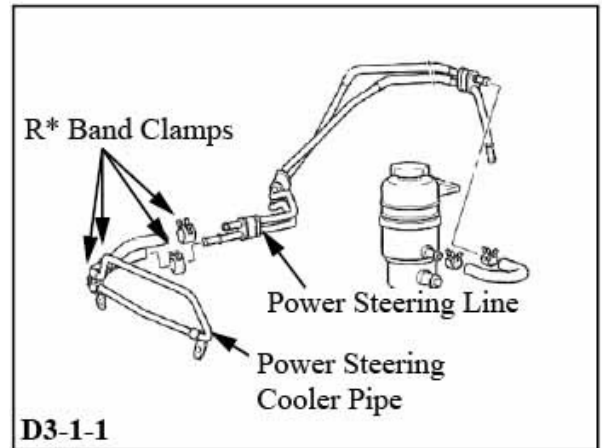

6. Invert the power steering cooler pipe vertically, and use the Power Steering Pipe Bracket (P6 x2) to relocate and mount onto the vehicle. (D3-1-4, D3-1-5) Relocate the bracket located in the middle of the power steering cooler pipe by matching the mounting holes.

- Power Steering Pipe Bracket (P6 x2)
- Bolt M6 L=20 (P14 x 2)
- Bolt M8 L=15 (P16 x 2)
- Flanged Nut M6 (P19 x 2)
- Flanged Nut M8 (P20 x 2)
- Lock Washer M6 (P21 x 2)
- Lock Washer M8 (P22 x 2)
- Flat Washer M6 Large A (P23 x 2)
- Flat Washer M8 (P25 x 2)
- Oil Resistant Hose 10mm (P13 x 1) (Cut to length 480mm)
- Corrugated Tube 15mm (P28 x 1) (Cut to length 250mm)
- Hose Clamp (factory x 4)

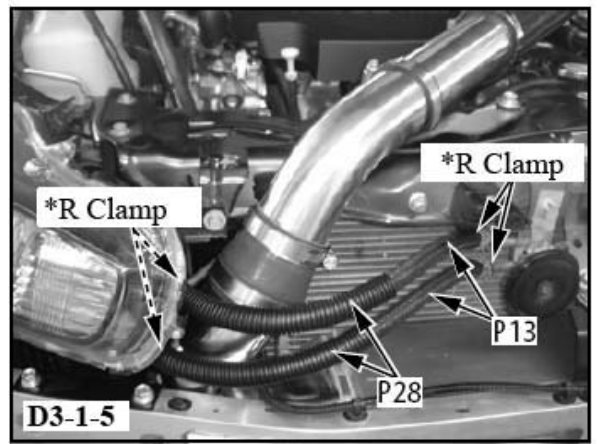
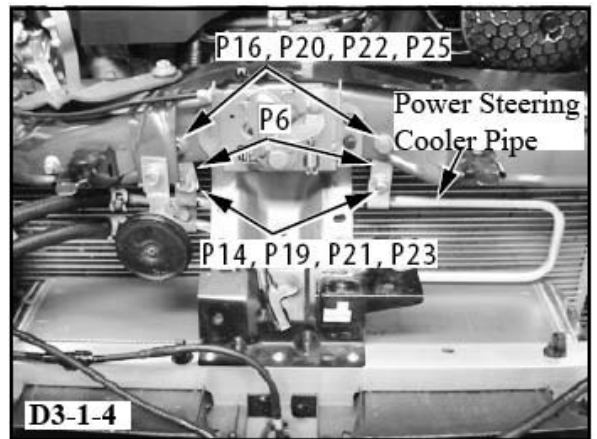

3-2) Relocating the AC Condenser

1. In order to relocate the AC condenser approximately 5mm to the vehicle's left, cut the AC condenser's right-side stoppers x 2. (D3-2-1, D3-2-2)

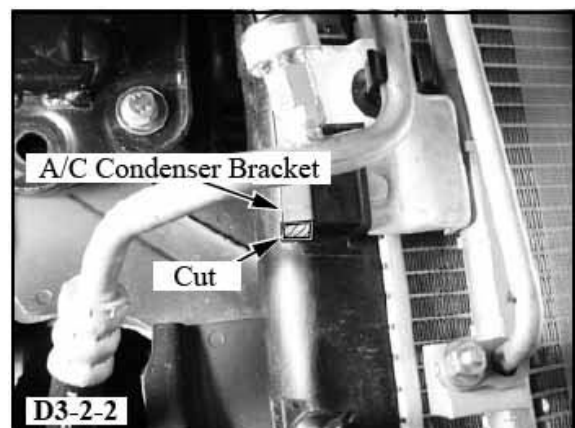
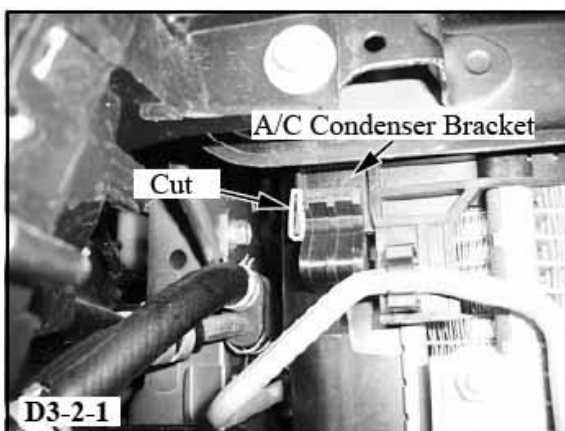

2. Move the AC condenser to the vehicle's left, and cut off width 5mm tabs as illustrated to create gaps in the bracket. Insert tie wraps into the newly created gap and tie off such that the condenser does not shift side to side. (D3-2-3, D3-2-4)

- Tie Wrap (L) (P10 x 1)

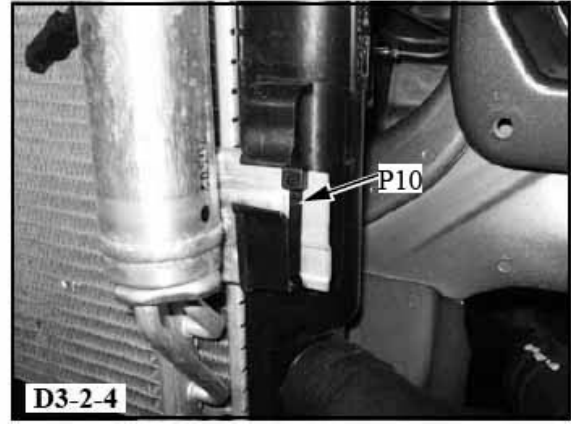
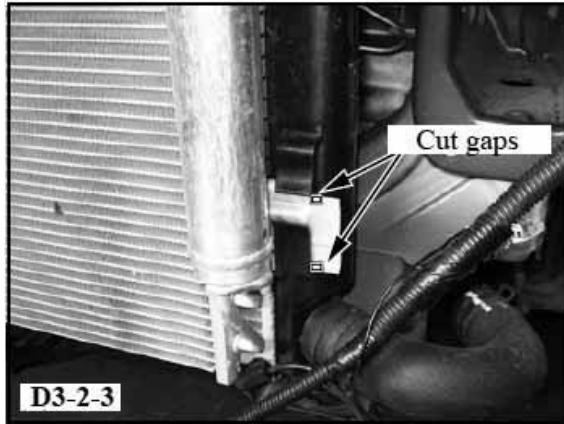

3-3) Intercooler Core Assy Installation

1. Install Intercooler Bracket No.2 to the position depicted in diagram D3-3-1.
 - Intercooler Bracket No.2 (P4 x 2)
 - Bolt M6 L=20 (P14 x 2)
 - Flanged Nut M6 (P19 x 2)
 - Lock Washer M6 (P21 x 2)
 - Flat Washer M6 Large A (P23 x 2)
 - Bolt (factory)
2. Pre-tighten the lower bolt of the Intercooler Core Assy, and note the sections that are coming into contact with other parts. Once noted and marked, remove the Intercooler Core Assy. Collars will be used between Intercooler Bracket No.2 and the bottom of the Intercooler Core Assy.
 - Intercooler Core Assy (P1 x 1)
 - Bolt M8 L=20 (P17 x 2)
 - Lock Washer M8 (P22 x 2)
 - Flat Washer M8 (P25 x 2)
 - Collar (P29 x 2)
3. The Intercooler Core Assy's tank bottom will come into contact with the AC pipe (thin). Bend back the AC pipe (section A in diagram) towards the rear of the vehicle. (D3-3-2)

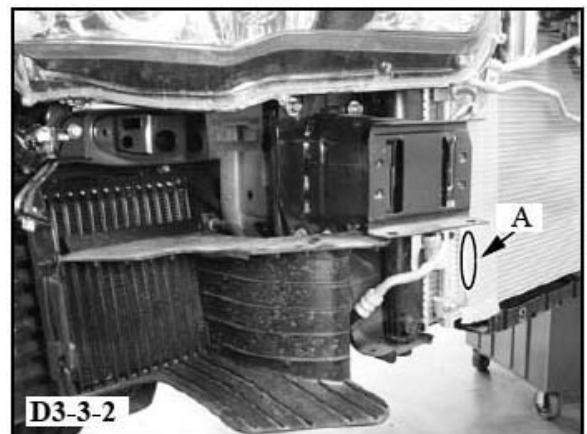
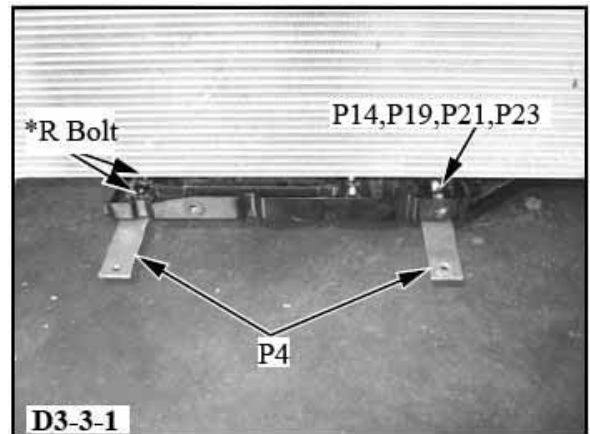

CAUTION: To prevent AC gases from leaking, do not apply strength/force near the flanged sections of the pipe. This is a thin pipe; take extra care and make sure the pipe is bent at a large radius to prevent cracks in the pipe.

- Cut off highlighted sections of the right-side headlight support upper panel bracket that comes into contact with the Intercooler Pipe. (D3-3-3)

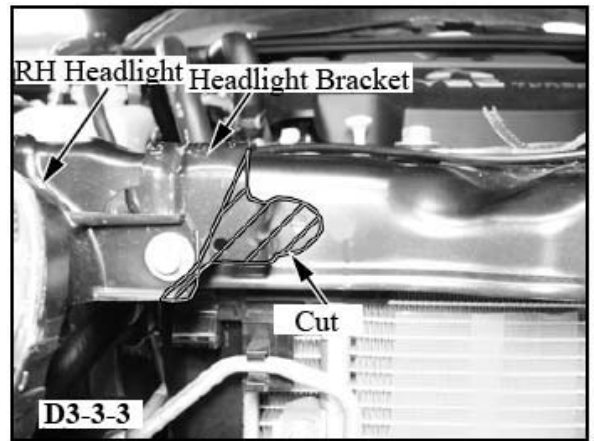

3-4) Modifying the Front Bumper Reinforcement

- Remove the power steering pipe bracket from the front bumper reinforcement.

NOTE: Cut/shave off the rivet heads to remove.

- Cut off the protruding sections of the front bumper reinforcement center bracket as illustrated in diagram D3-4-1.

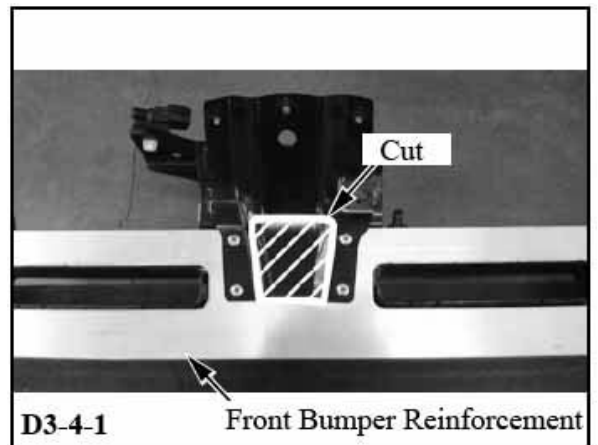

- Cut off sections of the front bumper air guide center duct that protrudes out from the reinforcement once installed. (D3-4-2)

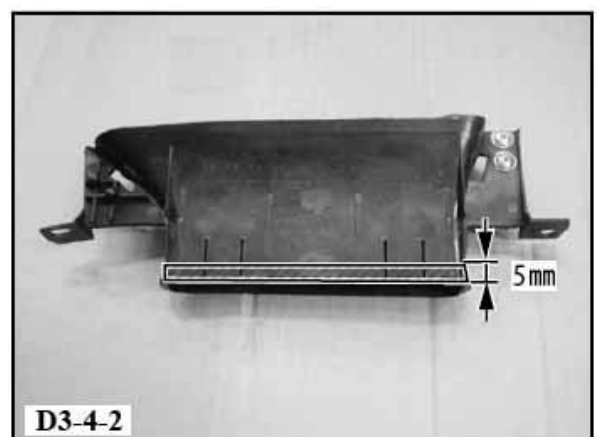

4. Temporarily install the front bumper reinforcement, and verify the tank weld positions of the Intercooler Core Assy. If there is insufficient room, modify the reinforcement as necessary. (D3-4-3, D3-4-4)

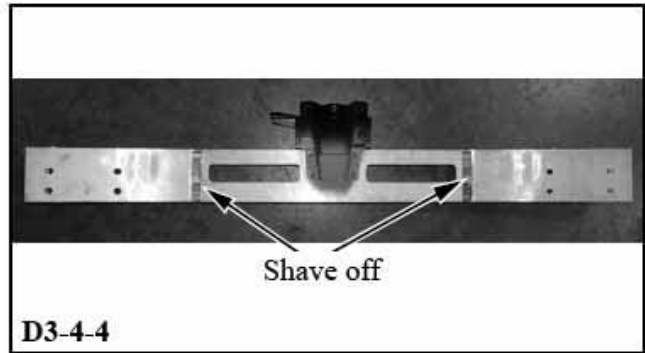
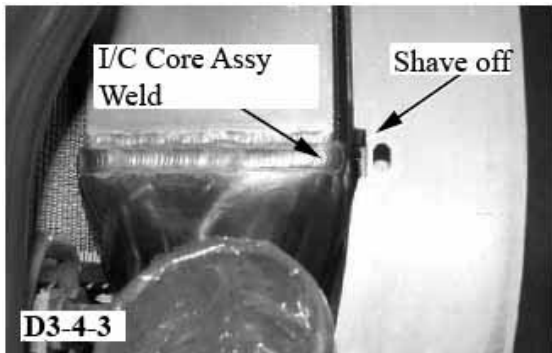

5. With the front bumper reinforcement temporarily installed, switch out the bolts in section A illustrated in diagram D3-4-5 with kit parts listed below.

- Bolt M8 L=20 (P17 x 1)
- Lock Washer M8 (P22 x 1)
- Flat Washer M8 Large (P26 x 1)

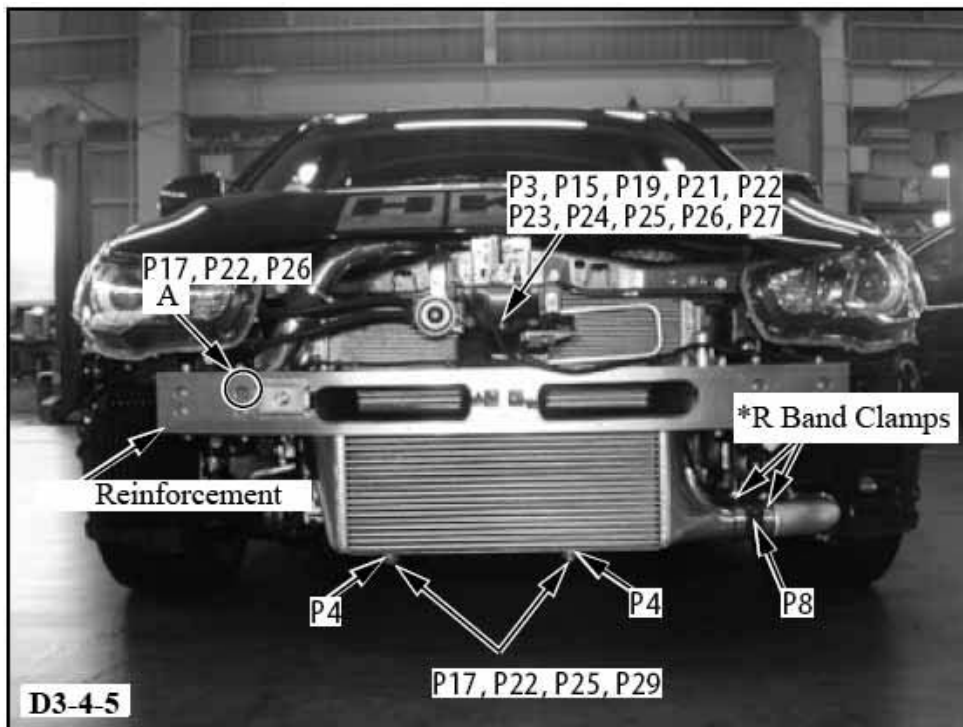

6. Install Intercooler Bracket No.1 onto the vehicle. Pre-tighten the bolts that correspond to the Intercooler Core Assy. (D3-4-5, D3-4-6)

- Intercooler Bracket No.1 (P3 x 1)
 - Bolt M6 L=25 (P15 x 1)
 - Bolt M8 L=25 (P18 x 1)
 - Flanged Nut M6 (P19 x 1)
 - Lock Washer M6 (P21 x 1)
 - Lock Washer M8 (P22 x 1)
 - Flat Washer M6 Large A (P23 x 1)
 - Flat Washer M6 Large B (P24 x 1)
 - Flat Washer M8 (P25 x 1)
 - Flat Washer M8 Large (P26 x 3)
 - Flat Washer M12 (P27 x 1)
- Silicone Hose 60mm-70mm Transition (P8 x 1)
Hose Clamp (factory x 2)

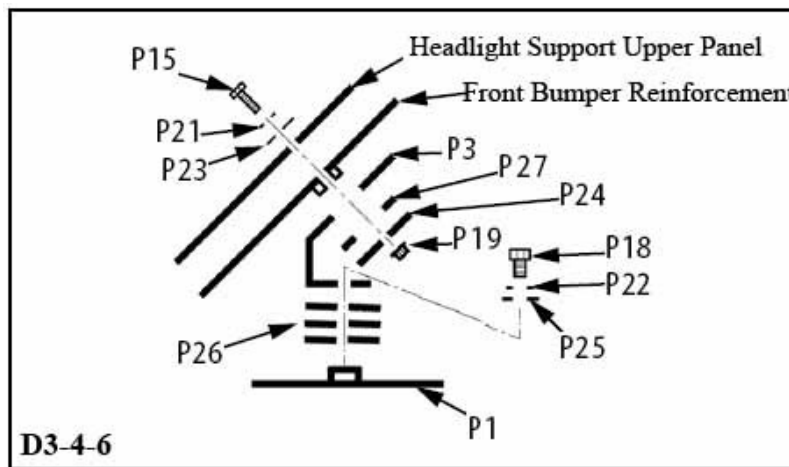

7. Verify the clearance between the inlet tank of the Intercooler Core Assy and the AC pipe (thick), and adjust the Intercooler Core Assy's vertical height by inserting three flat washers between the Intercooler Bracket No.1 and the Intercooler Assy to act as spacers. (D3-4-7, D3-4-8) *If two flat washers are used under Bracket No.1, use the remaining flat washer on top of Bracket No.1.

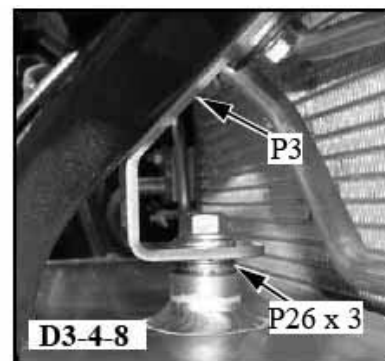
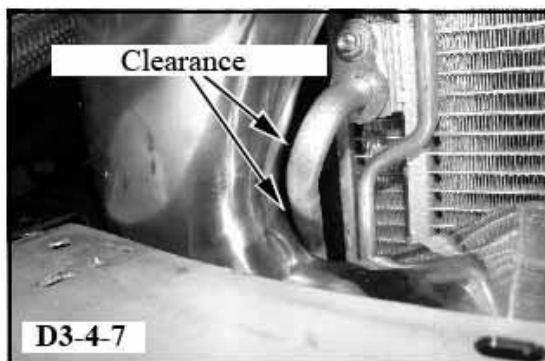

8. Check for proper clearances, and that the Intercooler Core Assy is not coming into contact with other parts. Properly tighten the Intercooler Core Assy and Intercooler Bracket No.1 onto the vehicle.

9. Intercooler Core Assy may come into contact with the factory intercooler bracket (RH) on the front bumper reinforcement. Cut off the illustrated sections in diagram D3-4-9 to prevent this.

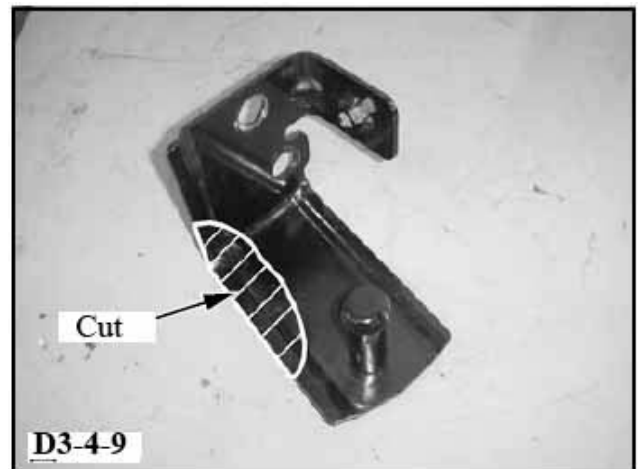

3-5) Installing Intercooler Inlet Pipes

1. Remove the rubber grommet from the factory intercooler pipe.

2. Install the rubber grommet removed in the previous step onto the Inlet Pipe Bracket. (D3-5-1)
 - Inlet Pipe Bracket (P5 x 1)

3. Install the Inlet Pipe Bracket (with rubber grommet) onto the frame. (D3-5-2)
 - Inlet Pipe Bracket (P5 x 1)
 - Bolt (factory x 2)

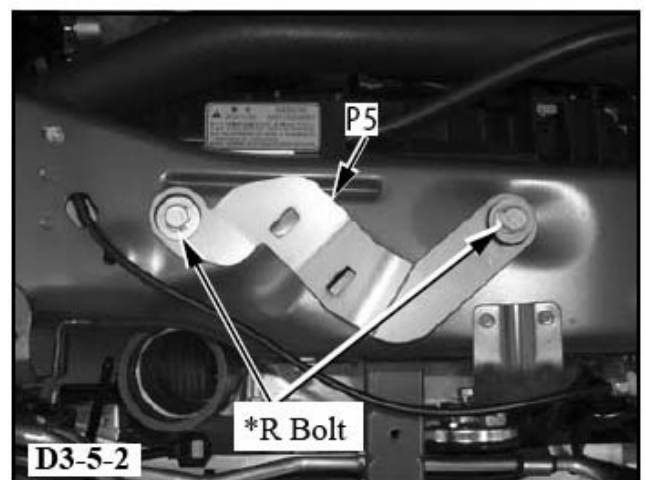
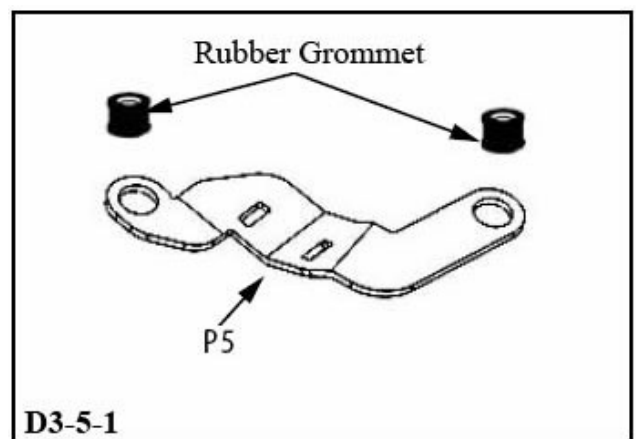

4. Temporarily install the Intercooler Inlet Pipe to the Intercooler Core Assy. (D3-5-3)

- Intercooler Inlet Pipe No.3 (P2 x 1)
- Silicone Hose 70mm L=70 (P7 x 1)
- Hose Clamp #40 (P12 x 1)
- Rubber Insulator (P11 x 1)
- Hose Clamp (factory x 2)

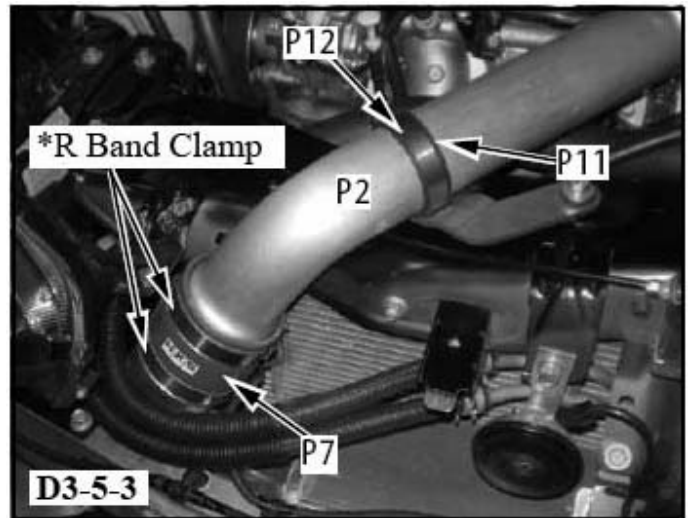

5. Temporarily install the Intercooler Inlet Pipe onto the factory intercooler hose. (D3-5-4)

- Intercooler Inlet Pipe (P2 x 1)
- Hose Clamp (factory x 1)

6. Verify all clearances and properly tighten each hose clamp. (D3-5-3, D3-5-4)

NOTE: Make sure there is at least 1 cm of clearance between intercooler pipes and that joint hoses are centered.



4. Reinstalling Factory Parts

1. Connect the coupler to the AC pressure switch, and secure the harness to the AC pipe. (D4-1)
 - Tie Wrap M (P9 x 1)

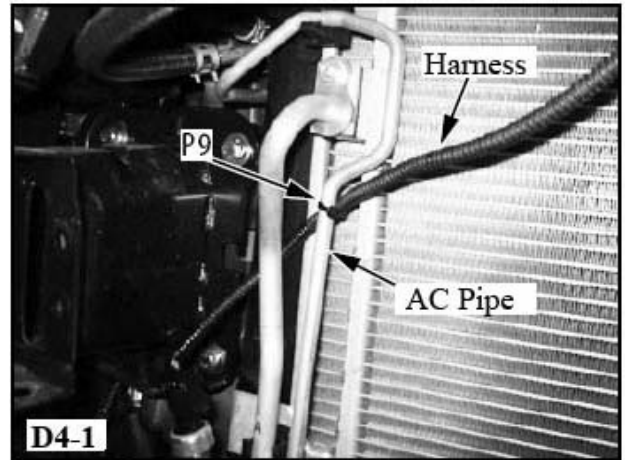

2. Install the front bumper air guide center duct onto the reinforcement, and temporarily re-install the front bumper assy onto the vehicle. If the air guide comes into contact with the Intercooler Core or front bumper, remove and cut off the illustrated sections in diagram D4-2.
3. Reinstall the factory engine room under cover front A, engine room under cover front B, and engine room under cover center back onto the vehicle.

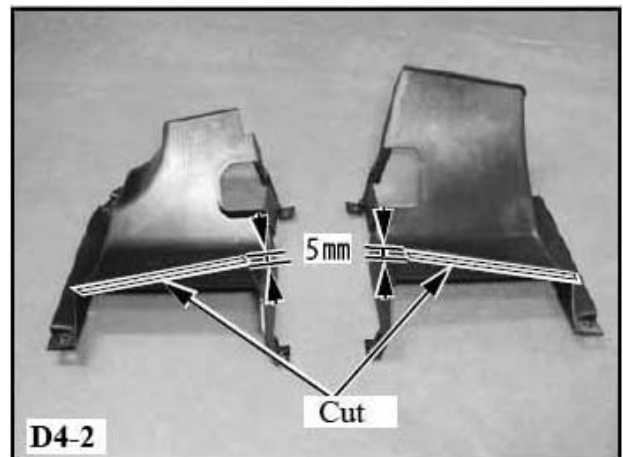

4. Shave off the ribs from the headlight support cover and reinstall onto the vehicle. (D4-3)

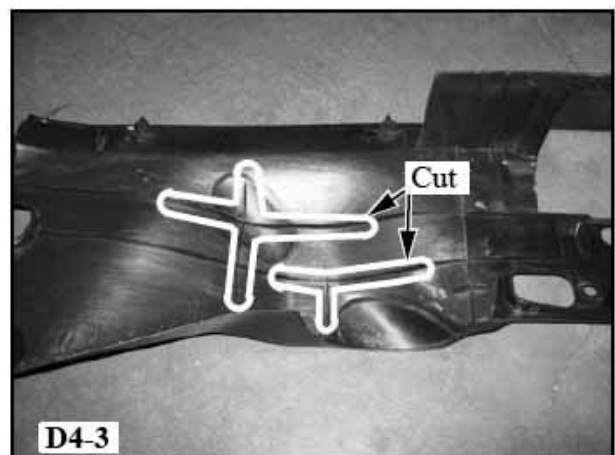

Procedures After Installation

1. Reconnect the negative terminal cable to the vehicle's battery.
2. Bleed and top off the power steering fluid as follows:

NOTE: Do not turn the steering wheel with the engine on, as micro-beads of air can enter the power steering fluid, making the bleeding process more difficult.

3. Jack up the front of the vehicle and support the vehicle on jack stands.
4. Disconnect the crank angle sensor. (D5-1)
5. Refill power steering fluid such that the reservoir tank does not fall below minimum (MIN) levels.
6. Intermittently (within 15-20 seconds) crank the engine, and turn the steering wheel right and left until it locks, repeat 5-6 times.
7. Reconnect the crank angle sensor, turn on the engine and let it idle.

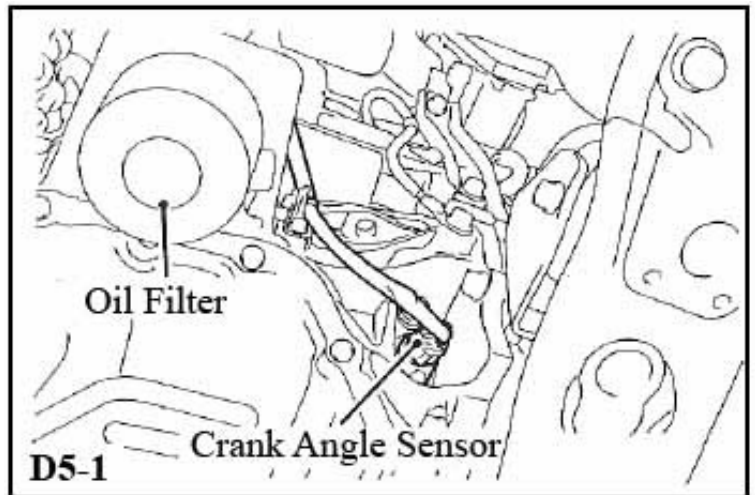







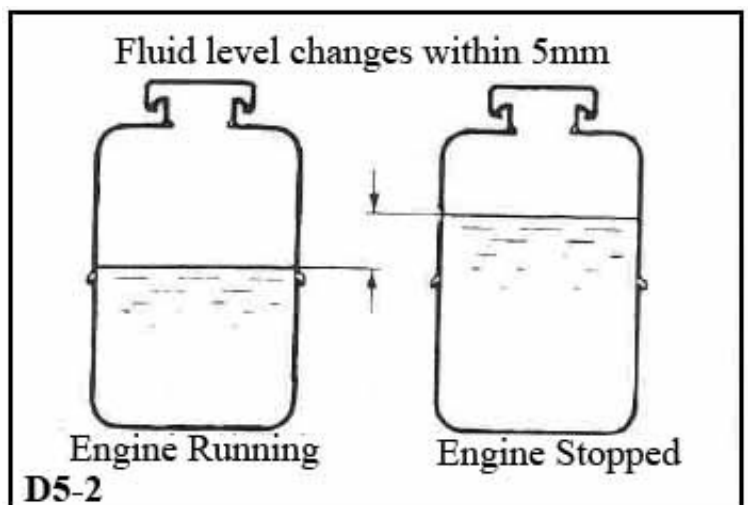







8. Turn the steering wheel right and left until the oil reservoir stops bubbling. (Bleed the air out)
9. Verify that the power steering fluid is no longer cloudy, and that the fluid levels are within minimum and maximum levels in the reservoir tank.
10. Verify that power steering fluid levels do not fluctuate dramatically when turning the steering wheel.







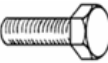
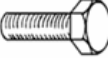
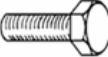
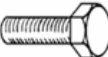





CAUTION: If the power steering fluid levels rise dramatically after turning off the engine, the bleeding process is not complete. If the bleeding process is not performed correctly, the oil pump may make unusual noises and can compromise the life of the oil pump.

11. Check and verify that the power steering fluid levels do not fluctuate more than 5mm after turning the engine on and off.
12. If the power steering fluid levels fluctuate more than 5mm above, the bleeding process is not complete. Bleed the power steering fluid again.



PARTS LIST

No.	Part Number	Description	Qty	Image	Notes
1	G17910-M40011-00	Intercooler Core Assy	1		
2	G17951-M40030-00	Intercooler Inlet Pipe	1		
3	G17921-M40010-00	Intercooler Bracket No.1	1		
4	G17921-M40020-00	Intercooler Bracket No.2	2		
5	G17961-M40010-00	Inlet Pipe Bracket	1		
6	G44461-M41010-00	Power Steering Pipe Bracket	2		
7	1803-SA030	Silicone Hose 70mm L=70	1		
8	G09115-K00030-00	Silicone Hose 60mm-70mm Transition	1		
9		Tie Wrap M	2		
10		Tie Wrap L	1		
11	17367-027396	Rubber Insulator	1		
12	18005-AK009	Hose Clamp #40	1		
13	1801-SA006	Oil Resistant Hose 10mm	1		L=1000
14		Bolt M6 L=20	4		P=1.0
15		Bolt M6 L=25	1		P=1.0
16		Bolt M8 L=15	2		P=1.25
17		Bolt M8 L=20	4		P=1.25
18		Bolt M8 L=25	1		P=1.25

No.	Part Number	Description	Qty	Image	Notes
19		Flanged Nut M6	5		
20		Flanged Nut M8	2		
21		Lock Washer M6	5		
22		Lock Washer M8	6		
23		Flat Washer M6 Large A	5		6.6x17.7 T=1.6
24	G90311-062101-03	Flat Washer M6 Large B	1		6x25 / T=2
25		Flat Washer M8	5		
26		Flat Washer M8 Large	4		8.6x21.8 T=1.6
27		Flat Washer M12	1		
28	G99551-015003-00	Corrugated Tube 15mm	1		L=500
29	94501-157100	Collar	2		10x20 / T=5
30	E04251-M40040-00	Instruction Manual (Eng)	1		USD M