

205820A Foot-Mount Bracket FOR DIRECT COUPLED ACTUATORS

INSTALLATION INSTRUCTIONS

APPLICATION

This document provides installation instructions for the 205820A Foot-Mount Bracket for three-point mounting of a Direct Coupled Actuator (DCA).

SPECIFICATIONS

Parts Included:

- Bracket (1).
- Hexagonal Standoffs (3).
- Screws (3).
- Lockwashers (3).

INSTALLATION

When Installing this Product...

1. Read these instructions carefully. Failure to follow them could damage the product or cause a hazardous condition.
2. Check the ratings given in the instructions and on the product to make sure the product is suitable for your application.
3. Installer must be a trained, experienced service technician.
4. After installation is complete, check out product operation as provided in these instructions.

Mounting

Mounting varies slightly for some DCA models. High-torque (150 lb-in. and 300 lb-in.) DCA do not require standoffs.

Standard Mounting

1. Using three 1/4 in. (6 mm) screws and lockwashers, attach the 1/2 in. (13 mm) hexagonal standoffs to the bracket. See Fig. 1.
2. Using any two of the five mounting holes, mount the bracket to the mounting surface.
3. Attach the DCA to the open end of the hexagonal standoffs with three 1/4 in. screws and lockwashers. See Fig. 2.
4. Remove the actuator output hub, if desired. See the instructions provided with the actuator.
5. Perform wiring and operating procedures for the actuator. See the instructions provided with the actuator.

High-Torque Mounting

1. Using any two of the five mounting holes, mount the bracket to the mounting surface.
2. Attach the DCA to the bracket with three 1/4 in. screws and lockwashers. See Fig. 3.
3. Remove the actuator output hub, if desired. See the instructions provided with the actuator.
4. Perform wiring and operating procedures for the actuator. See the instructions provided with the actuator.

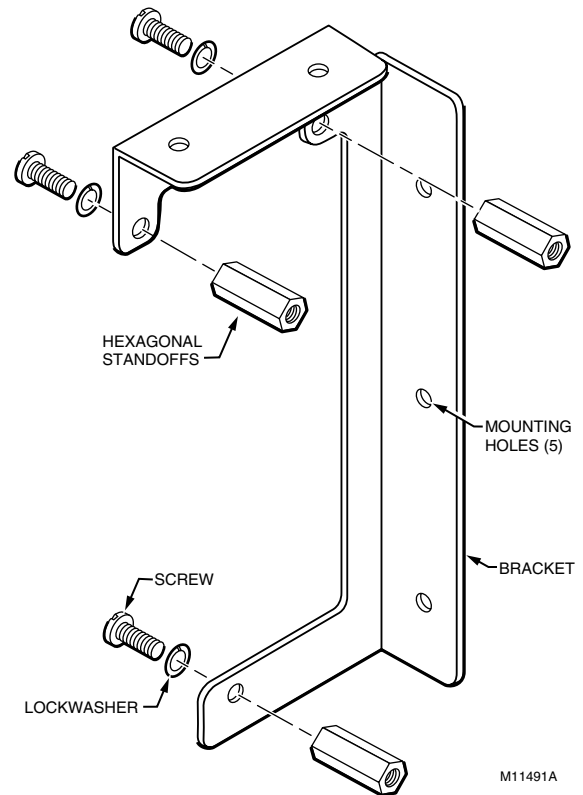

Fig. 1. 205820A Foot-Mount Bracket.



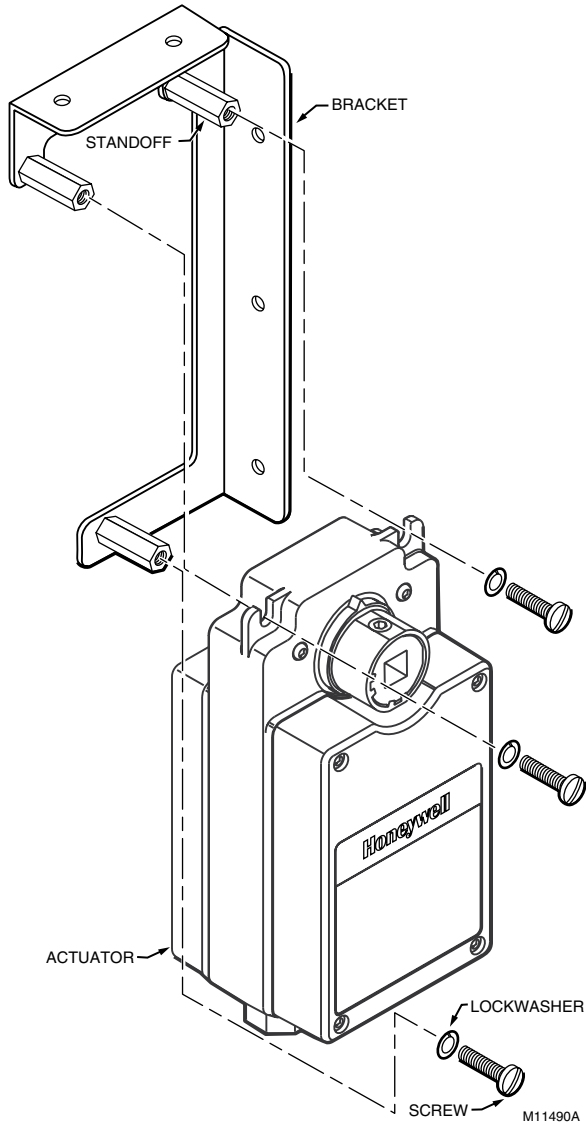

Fig. 2. Mounting the DCA on bracket using standoffs.

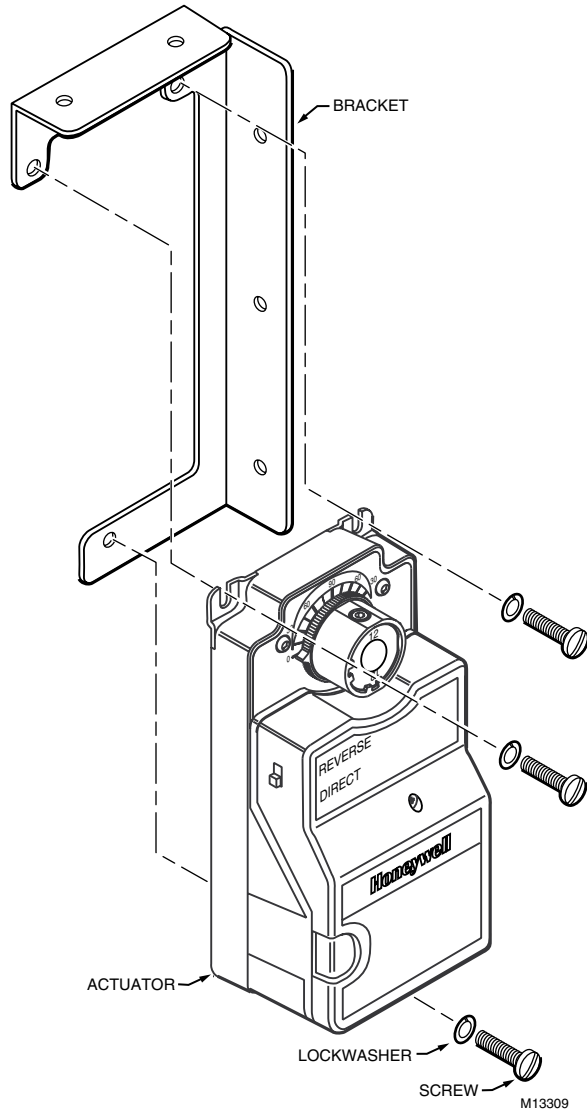

Fig. 3. Mounting a high torque DCA on bracket.

By using this Honeywell literature, you agree that Honeywell will have no liability for any damages arising out of your use or modification to, the literature. You will defend and indemnify Honeywell, its affiliates and subsidiaries, from and against any liability, cost, or damages, including attorneys' fees, arising out of, or resulting from, any modification to the literature by you.



Automation and Control Solutions

Honeywell International Inc.	Honeywell Limited—Honeywell Limitée
1985 Douglas Drive North	35 Dynamic Drive
Golden Valley, MN 55422	Scarborough, Ontario M1V 4Z9



Printed in U.S.A. on recycled paper containing at least 10% post-consumer paper fibers.