

Honeywell

220738A Adapter Bracket

INSTALLATION INSTRUCTIONS

APPLICATION

The 220738A Adapter Bracket can be used with all Modutrol IV motors. The adapter bracket raises the shaft height of the Modutrol IV motors to match that of older Honeywell Modutrol motors (e.g., M934, M975, M944, M945 type). This is required on all valve linkage applications, Q607 Auxiliary Switch applications, and on some damper linkage applications (either to provide clearance for the crank arm to rotate through the downward position, or to allow the damper linkage to reach the shaft).

INSTALLATION

The adapter bracket raises the shaft height of the motors by 0.75 inch to match that of older Honeywell Modutrol motors (e.g., M934, M975, M944, M945 type).

When Installing This Product...

1. Read these instructions carefully. Failure to follow them could damage the product or cause a hazardous condition.
2. Check the ratings given in the instructions and on the product to make sure the product is suitable for your application.
3. Installer must be a trained, experienced service technician.
4. After installation is complete, check product out.



CAUTION

1. **Disconnect the power supply before beginning installation to prevent electrical shock and equipment damage.**
2. **Never turn the motor shaft by hand or with a wrench. This will damage the motor.**
3. **Always conduct a thorough checkout when installation is complete.**

Location

You may mount the motor in any position as long as the shaft remains horizontal. Install the Modutrol motor in any location except where acid fumes or other deteriorating vapors might attack the metal parts, or in atmospheres of escaping gas or explosive vapors. Allow enough clearance for installing accessories and servicing the motor when selecting a location. The wiring box provides NEMA 3 weather protection (shown in Figs. 1 and 2).

Damper Linkages

Use of the 220738A Adapter Bracket packed with the Modutrol IV motors is optional for many damper applications. In applications requiring the crank arm to rotate through the bottom plane of the actuator, the adapter bracket or the new crank arm, which is shorter than the original crank arm, must be used. If the bracket is not used in a replacement application, the damper linkage will have to be adjusted to the new shaft location.

For damper linkage applications: First mount the bracket to the equipment with existing or standard bolts. Then mount the motor to the bracket using the bolts provided (see Fig. 1).

Notice the difference between the configuration for mounting of the spring return motor versus the nonspring return motor to the adapter bracket as shown in Fig. 1.

Valve Linkages

The 220738A Adapter Bracket must be used with the 0100, 0601, 0618 linkages in all valve applications.

For valve linkage applications: The bracket should first be mounted to the valve linkage. Hand tighten screws only until motor is secured to bracket. The bracket then provides a convenient base on which the motor can be positioned. After the motor shaft is aligned to the valve linkage, it can then be attached to the bracket with the four bolts provided (see Fig. 2).

Notice the difference between the configuration for mounting of the spring return motor versus the nonspring return motor to the bracket as shown in Fig. 2.



63-2216-02

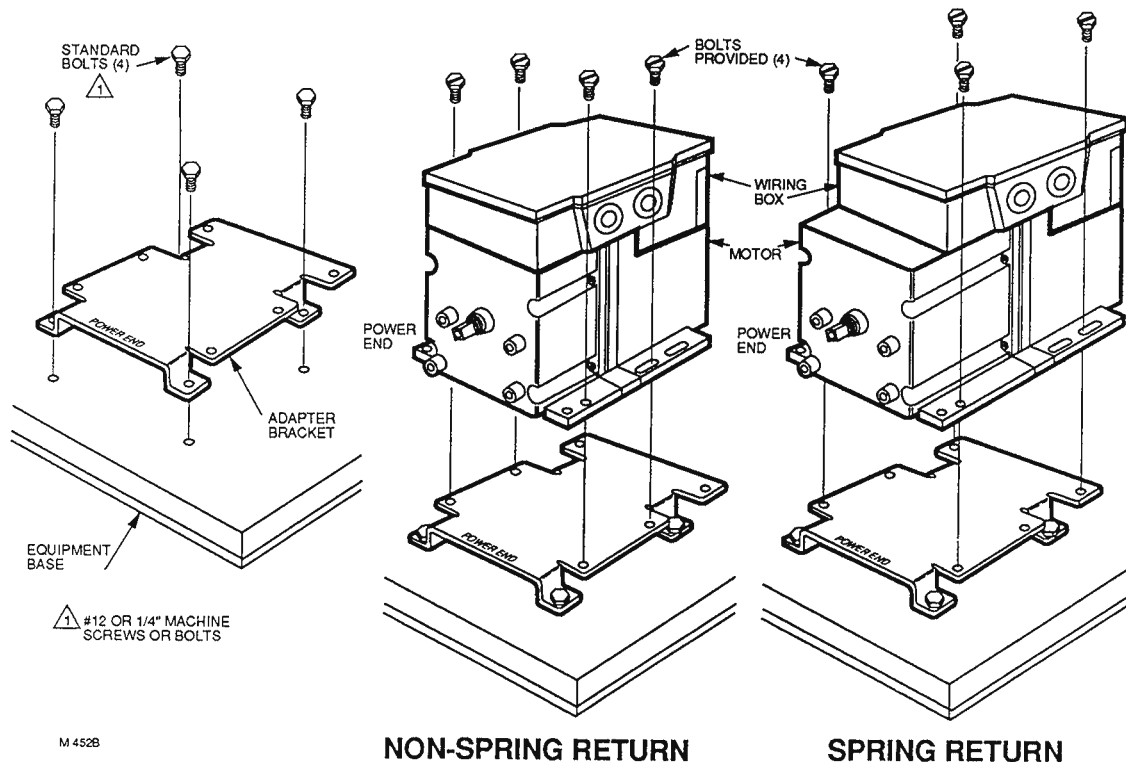

Fig. 1. Damper Application. First mount adapter bracket to equipment, then mount motor to bracket using bolts provided.

CHECKOUT

For detailed instructions on the assembly of specific linkages, refer to the instruction sheet packed with each linkage. In general, however, check the following points of operation when installing a motor and linkage:

1. Linkages for valves and louver type dampers should be adjusted so that the damper or valve moves through only the maximum required distance when the motor moves through its full stroke.
2. With modulating control, maximum damper opening should be no more than 60°. Little additional airflow is provided beyond this point.
3. The motor must be stopped at the end of its stroke by the limit switch and must not be stalled by the damper or valve. The motor will be damaged if it is not permitted to complete its full stroke.
4. Do not exceed the motor ratings in any installation.
5. Do not turn motor shaft manually or with a wrench. This will damage the motor.

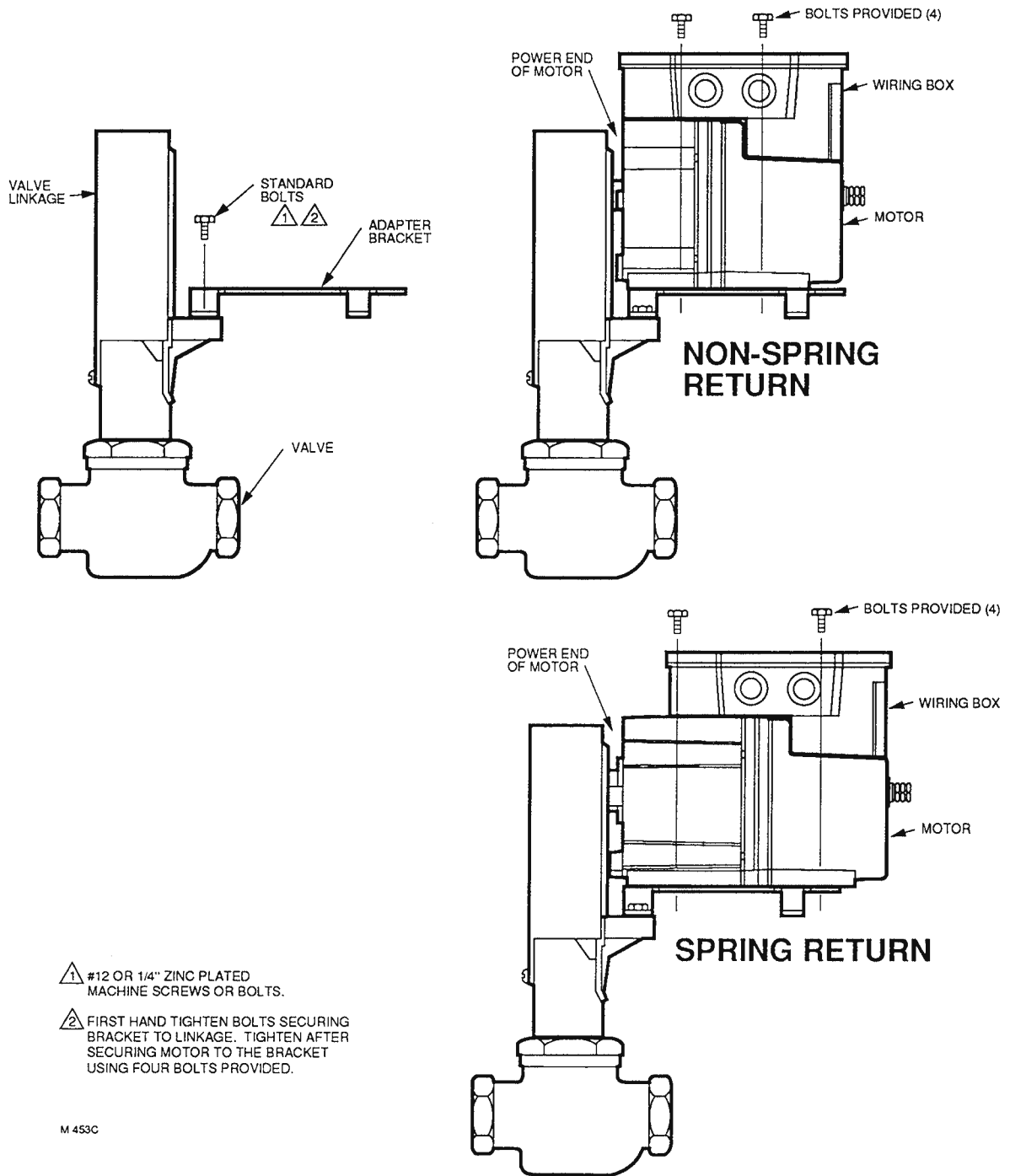

Fig. 2. Valve Linkage Application. First mount adapter bracket to the linkage, then mount motor to bracket using bolts provided.

Honeywell Building Technologies

In the U.S.:

Honeywell

715 Peachtree Street NE

Atlanta, GA 30308

customer.honeywell.com

buildingcontrols.honeywell.com

® U.S. Registered Trademark
©2021 Honeywell International Inc.
63-2216-02 M.S. Rev. 01-21
Printed in United States

Honeywell