

# Fire Control and Repeat panels

## (Conventional 1, 2, 4 and 8 Zone panel range)

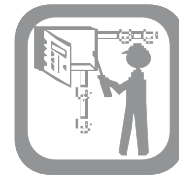

This manual covers a range of conventional fire panel and include system design, installation and configuration information.

The fire panels covered are designed in accordance with the requirements of EN54-2: 1997, A1:2006, plus the requirements of EN54-4: 1997, A1:2002, A2:2006. This publication covers the Conventional fire alarm panels:

- 2 zone panel:- 13270-02LB and 75585-02NMB
- 4 zone panel:- 13270-04LB and 75585-04NMB
- 8 zone panel:- 13270-08LB and 75585-08NMB
- Fire alarm repeat panel: 13271-08LB and 75586-08NMB.

The panels are supplied without batteries.

**This manual is intended for use by installers and commissioning engineers.**

**A separate Operating instructions and Log book has been supplied along with this**

**booklet which must be forwarded on to the End User.**

### Symbols on product



Electric shock hazard.



Protective Earth connection terminal.



The WEEE symbol. It indicates the product is to be recycled and not thrown away.



The CE compliance logo. This product is in conformity with the relevant European Union harmonisation legislation.



The RoHS compliance logo. The RoHS directive restricts the use of certain hazardous substances commonly used in electronic and electronic equipment.



The UKCA (UK Conformity Assessed) marking is a new UK product marking that is used for goods being placed on the market in Great Britain (England, Wales and Scotland).

Content	Page
System design . . . . .	2
Cables - . . . . .	4
Notes to installers . . . . .	5
Panel fixing . . . . .	6
Terminals . . . . .	8
Controls & indicators . . . . .	9
Power up tests . . . . .	10
Installed system tests . . . . .	11
Config. considerations . . . . .	11
Access levels 2 . . . . .	12
Operating instructions for Access level 2 functions . . . . .	12
Programming Options . . . . .	14
Operating instructions for Access level 3 functions . . . . .	14
Operating instructions for Access level 4 functions . . . . .	15
Fault indications . . . . .	16
Fault finding . . . . .	17
Specification for the Control panel . . . . .	20
Specification for the Repeat panel . . . . .	22
Parts list . . . . .	23



### System design

The fire system design should be to *BS 5839:Part 1:2013 Code of Practice for system design installation and servicing*. Supplemented with customer requirements.

#### Mains Supply

The control panel mains supply must be via a fused spur unit rated:

- 5A - 2 Zone panel/Repeat panel
- 7A - 4 & 8 Zone panel

#### Standby Supply

With the recommended batteries the control panel will provide a standby supply under mains failure conditions. A period of 72 hours followed by 30 minutes of alarm load is possible and is dependent on the system loading.

#### 24V power supply

The power supply terminals '24+' and '0' may drive external ancillary equipment and is designed to be used in conjunction with auxiliary contacts and common fire and fault outputs. The maximum currents are 250mA (1 & 2 zone) and 500mA (4 & 8 zone). The supply is monitored for faulty 24V supply level or fuse blowing.

NOTE: Spur wiring is not permitted off zone circuits.

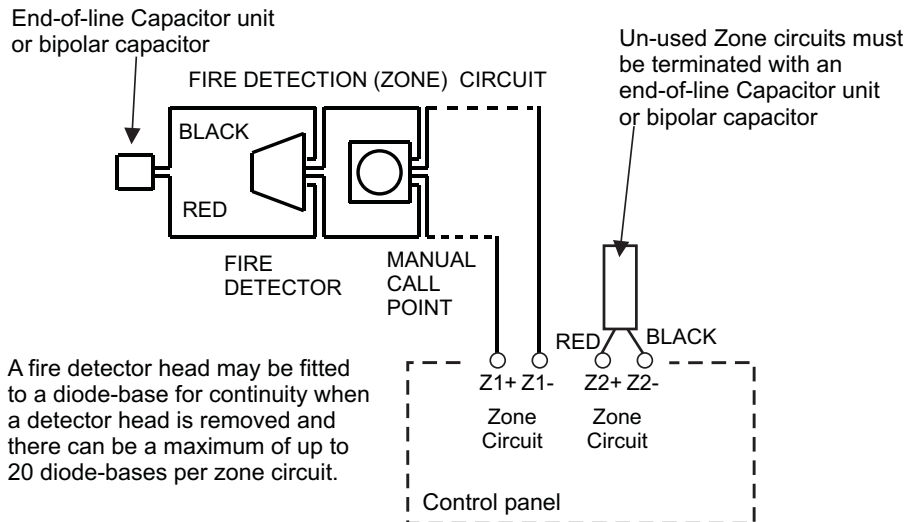

Figure 1 Zone circuit - used and unused

**NOTE:** The use of the 24V supply will affect the panel standby capability.

#### Fire Detection (Zone Circuits)

Each zone circuit can have up to 3.0mA load. An end-of-line capacitor unit or bipolar capacitor is required for zone circuit monitoring, which must be fitted after the last detector or manual call point on the circuit. **All manual call points used must have a 470 ohms series resistor.**

Where a zone circuit is not being used, the *end-of-line* capacitor unit or bipolar capacitor must be fitted across its terminals in the panel.

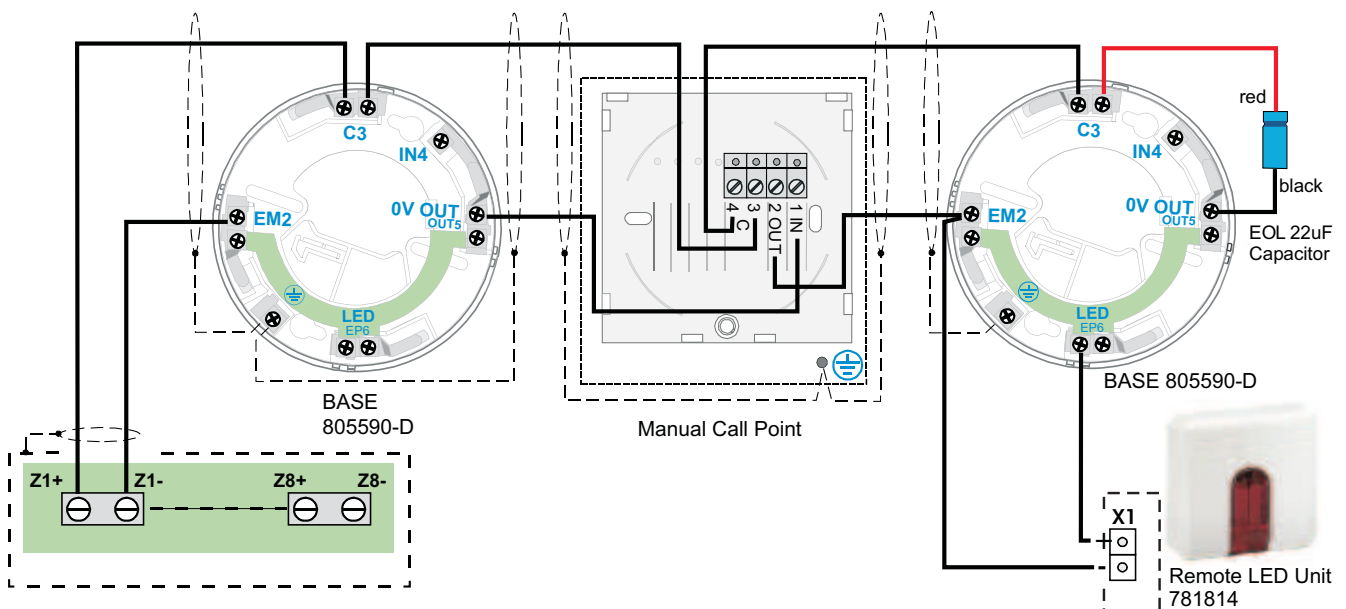
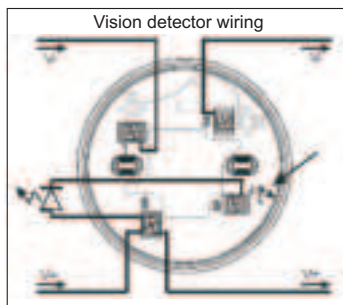

Figure 2 Connection to detectors, call points and panel

### Alarm (Sounder circuits)

To comply with the requirements of *BS 5839: Part 1:2013*, two or more alarm sounder circuits should be used on all installations.

**NOTE:** All sounder circuits (sectors) will operate together in the event of a fire condition.

**NOTE:** Each sounder output is 0.5A maximum protected by 0.75A fuse.

2 Zone Panels	4 & 8 Zone Panels
1A maximum Alarm sounder load per panel	1.5A maximum Alarm sounder load per panel

The load must be shared between the sounder circuits. The alarm sounder circuits are regularly pulse monitored for failure. It is important that the last alarm sounder is fitted with a **10K Ohm** end-of-line resistor.

The sounder outputs are monitored in alarm for loss of supply or multiple sounder output overloads

Where a sounder circuit is not being used, the *end-of-line* resistor must be fitted across its terminals in the control panel.

### Class Change

A pair of unmonitored terminals allow only the system alarm sounders to be activated from a remote position. It is considered that the major use for these will be for class change functions in schools and colleges.

### Auxiliary Contacts

These are normally open (NO) and normally closed (NC) contacts that change over when the panel goes into a fire condition. The contacts are rated at 24V dc 1A for a resistive load and should not be used to switch voltages in excess of 50V. The auxiliary circuits should be powered from an independent power supply.

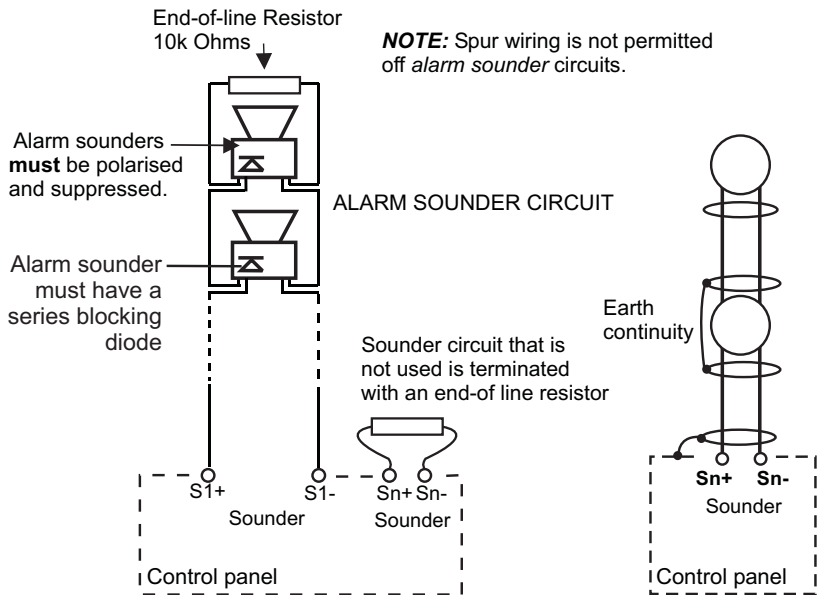

Figure 3 Alarm sounder circuit used and unused

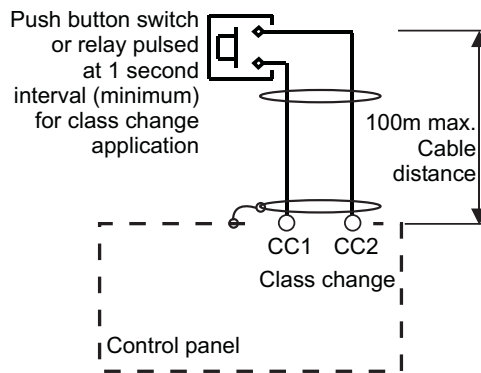

Figure 4 Class change circuit

NOTE: There is no indication given at the panel of class change push button operation.

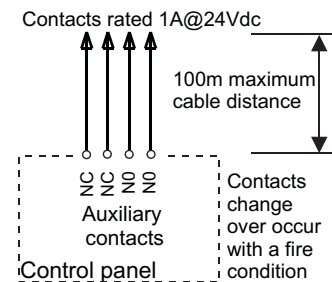

Figure 5 Auxiliary contacts

**Common Fire and fault**

The **common fire** output is a normally open electronic switch that closes with a fire condition.

The **common fault** output is a normally closed electronic switch, which opens with a fault condition, this is for a fail safe operation.

Each electronic switch is current limited, see specification.

Use a relay to provide volt free contacts.

The +24V & 0V is a power supply for use with auxiliary contacts, common fire and common fault circuits, see specification.

Figure 6 Fire fault & 24V outputs

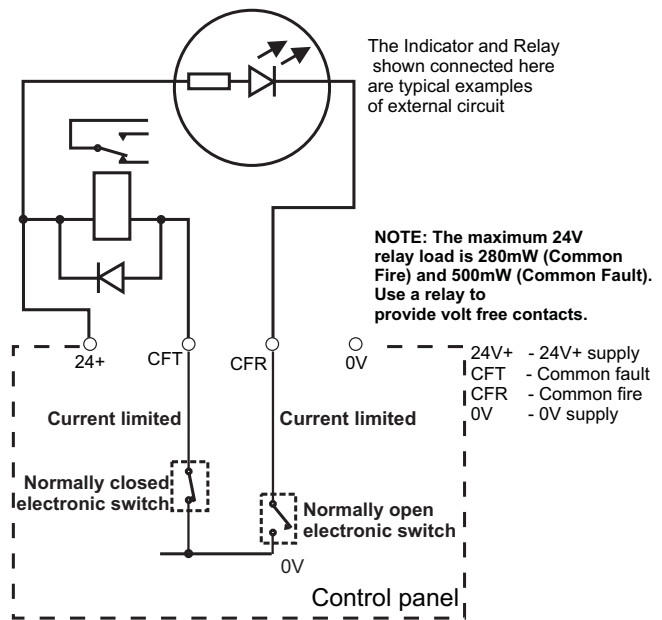

**Repeat Panel**

A Repeat panel can be connected in series to the control panel. A repeat panel duplicates fire and fault indications together with system controls.

Figure 7 Control to repeat panel connections

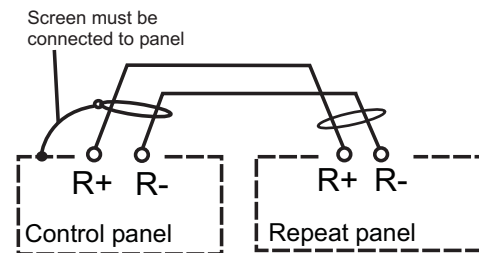

**Cables**

The guidance of BS5839:Part 1:2013, should be followed.

Generally available electrical installation cable may be used, providing the cable is:

- to BS6387
- with no more than 2 - cores
- each core having no less than 1.5mm<sup>2</sup> cross section area (maximum 2.5mm<sup>2</sup>).
- with an inherent or through metal conduit screen for earth continuity in order to produce electrical protection and screening.
- having protection from heat and mechanical damage.

**Power supply cord**

The mains supply to the panel should be wired in 0.75mm<sup>2</sup> cable with a effective connection to building service earth continuity conductor.

Length per circuit	Type of circuit	Recommended cables, also see BS5839:Part 1 guidance
2m	Mains power supply cord	see power supply cord
1Km	Zone circuit	See BS5839:Part 1:2002 + A2:2008 for guidance
1Km	Sounder circuits	
100m	Auxiliary circuit	
100m	Common fire and fault circuit	
100m	Class change circuit	
500m total circuit	Repeat panel link	Belden type - screened 2-core twisted pair

**Notes to installers**

**Check**

- The power-up and commissioning is done by the servicing organisation.
- The wires between the termination point and terminals should be **short** and **straight** as possible.
- The cables of the fire detection and alarm system and other systems should usually be separated by at least **160mm**, unless dedicated conduit or ducting is used.
- Do not use any part of building structure for earthing.
- The cable length between the Repeat LED unit and respective fire detector where used, should not exceed **10m**.
- Cable Glands should be used on the equipment for the mains supply cable.
- Unused knockouts on product enclosure that have been removed, should not be left open.

**Requirements**

It is recommended that the installer follow the general requirements of:

- BS5839:Part 1:2013*, which is the code of practice relating to the fire detection and alarm systems for buildings.
- the relevant parts of the *BS 7671 Requirements for Electrical Installation*.

**Second fix**

To prevent the possibility of damage or dirt degrading the performance or appearance of the System products, the installation of second fix items should be delayed until all major building work in the area is complete.

**Fixtures and fittings**

It is the installers responsibility to provide:

- adequate fixtures and fittings for the type of construction surface onto which a product is to be installed.
- as an aid to this decision, the weight and overall size of each full assembly together with implications on cable entries and routing should be taken into consideration.

**NOTE:** All these procedures assume that the cable, gland, steel box (BESA box) and other related accessories are provided by the installer.

**As fitted wiring drawings**

The installer should acquire:

- site specific information from the interested parties, for details on the location of products for installation
- the acquired information together with this guide and the relevant standards should be used to assist the work.

**Earth continuity**

To maintain earth continuity, the cable screen must be continued through each system device, whether the earth is connected to a device or not.

**NOTE:** The cable from the main panel to repeat panels if fitted must be a screened cable. Refer to Figure 8.

NOTE: Repeat panel link cable entries are located at the opposite end to the mains cable entries, ie on the Right Hand Side.

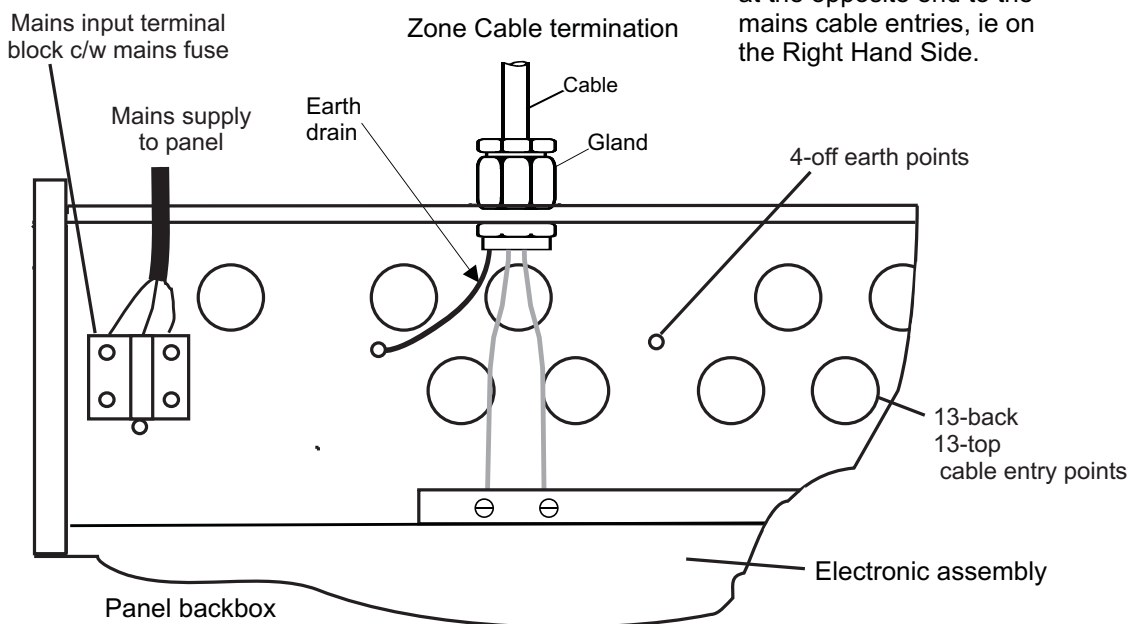

Figure 8 Panel cable entry and earth points

**Panel fixing**

- a) Remove panel from its carton.
- b) Store the front panel (including the electronic assembly) and the metal plates in a safe place until later.
- c) Check the spare parts supplied with those listed in *Table 1*.
- d) Remove the appropriate knock-in on the panel case for cable entry.
- e) Hold the panel on the wall in the desired mounting position and mark the positions of the fixing holes. See *Figure 9* for case fixing details.
- f) Secure the panel to the wall using suitable fixings. A top centre keyhole fixing is provided on the case to allow the panel to be hooked whilst the bottom two fixing points are located.

**NOTE:** For details on flush fixing the panel, see *Figure 11*.

- g) Connect the mains supply cable to the panel. The cable:
  - must be fed through one of the dedicated mains cable entry points into the panel.
  - must be via an **unswitched fused spur** unit, rated **5A** for the 2 Zone Control and Repeat panels and **7A** for 4&8 Zone panels.
  - The fused spur isolator cover should be red and marked: **FIRE ALARM - DO NOT SWITCH OFF**
  - The fused spur units must be fed from a dedicated isolation switch used for the fire alarm system only.
- h) Wire the system. With the exception of mains cable, all other cables should remain unconnected at the panel. For the unconnected cable leave **300mm** tail wire length and mark each core identifying its final point of connection. The system wiring can be tested whilst not connected to the respective terminals at each system device.

Description For fuse location see Figure 12	Quantity supplied with control panel			Repeat panel
	2 zone	4 zone	8 zone	
10K end-of-line resistor	2	4	8	
22uF Capacitor unit	2	4	8	
End of line label	4	8	16	
Fuse T3.15AH250V ceramic 20 x 5mm (mains FS1 & battery FS2)	2	2	2	2
Fuse F500mA250V 20 x 5mm (24V FS11)	1	1	1	
Battery link	1	1	1	1
Zone designation label	1	1	1	1
M3 screws	8	8	8	8

Table 1 Spare parts supplied with each panel

**CAUTION: DO NOT undertake high voltage insulation tests WITH THE CABLES CONNECTED to their terminals. This may damage the electronic circuitry in the product.**

**NOTE:** Each terminal in a panel will accept a maximum conductor size of 2.5mm<sup>2</sup>.

**NOTE:** The installation of all outstanding parts is usually carried out during Commissioning of the System.

- i) Refit the front panel (including the electronic assembly) into the panel using four M3 screws and connect the transformer cable and earth cable, see *Figure 10*.
- j) Attach the top and bottom metal plates using four M3 screws, see *Figure 11*.

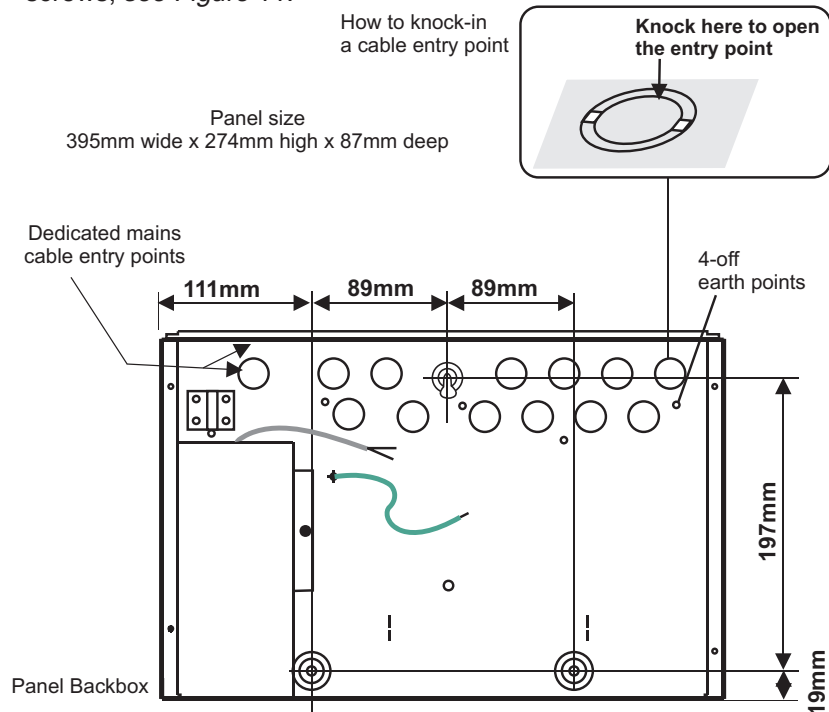

Figure 9 Panel fixings

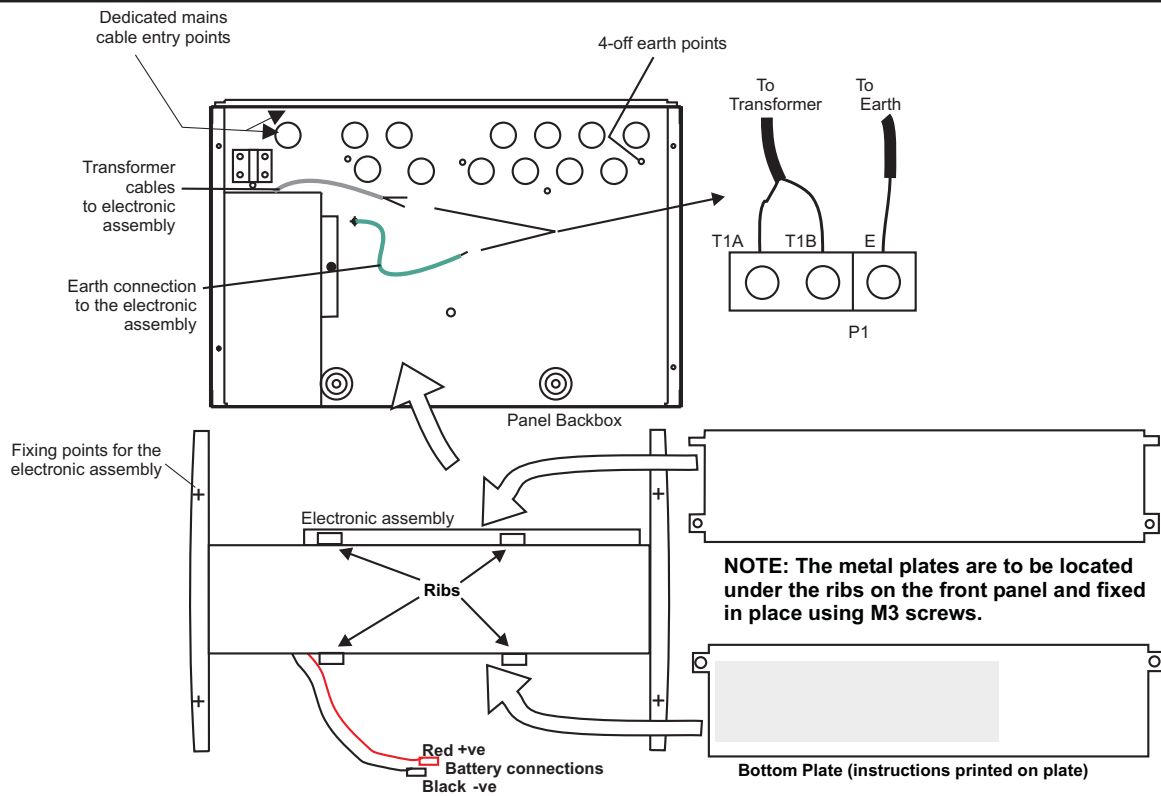

Figure 10 Refitting electronic assembly

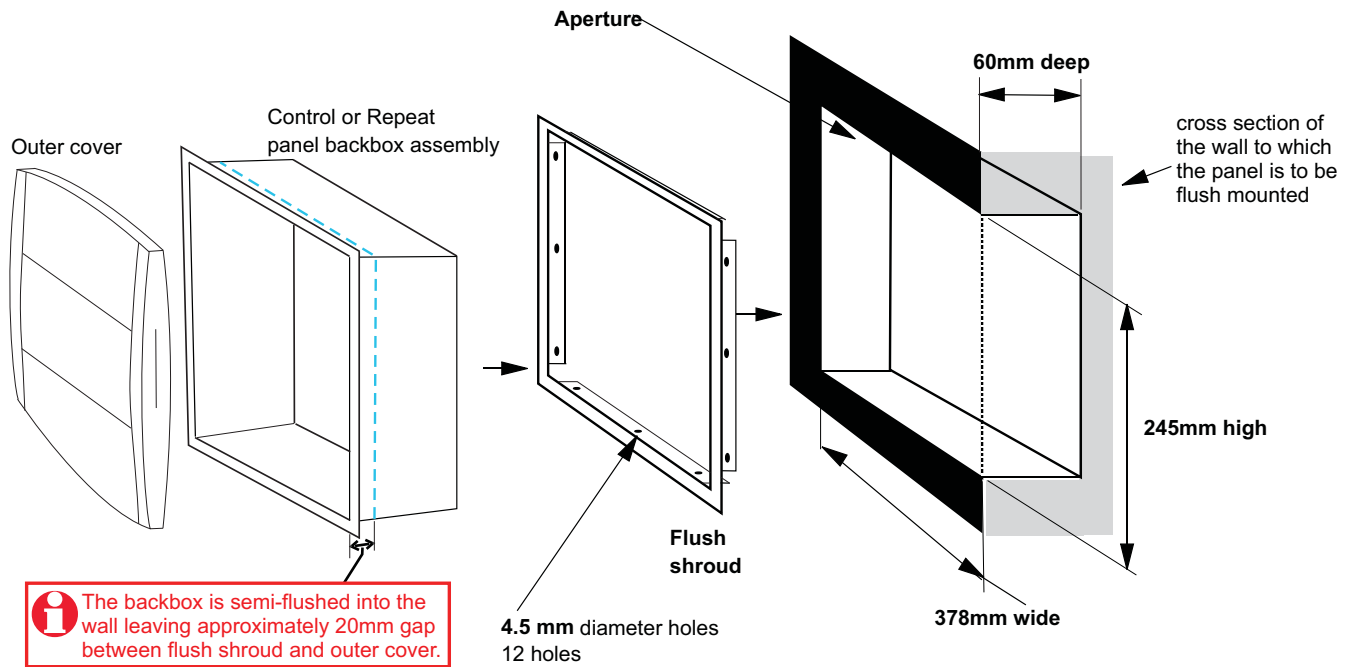
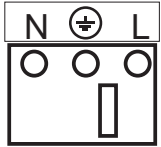

Figure 11 Installing a flush shroud

Store all spare parts and loose components including the batteries inside the panel carton and keep in a safe place until required.

Terminals

**CAUTION**  
HAZARDOUS VOLTAGES REMAIN  
AFTER OPERATION OF FUSE



Mains input supply

Product No: 13270 MAIN PANEL  
Rated Voltage: 230V A.C.  
Rated Current: 0.3A  
Rated Frequency: 50Hz  
Mains Fuse: FS1 T3.15AH250V  
Manufacture date: xx/xx/xx

To Zone and Sounder Circuits, where 'n' signifies circuit number 1 to 8

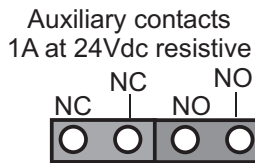

To transformer

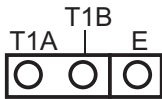

The shaded terminal blocks are not fitted on the Repeat panel.

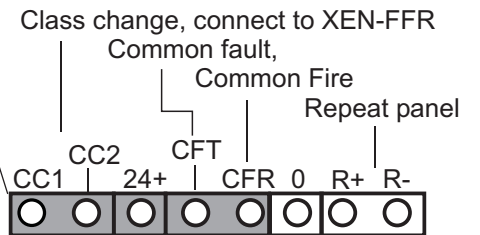

Software version label

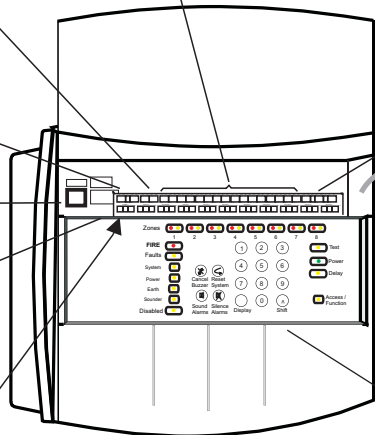

Panel

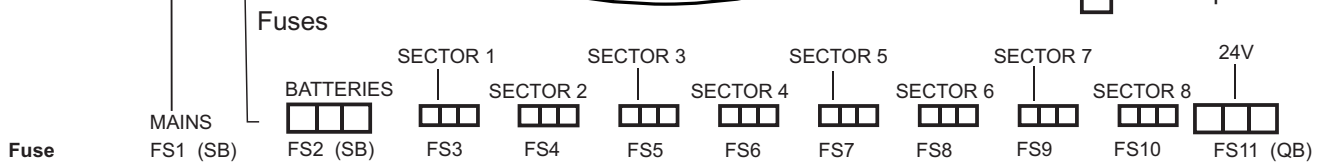
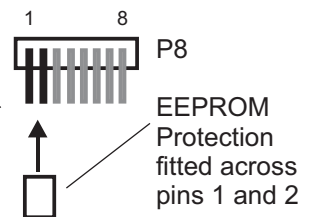

Fuse	MAINS FS1 (SB)	BATTERIES FS2 (SB)	SECTOR 1 FS3	SECTOR 2 FS4	SECTOR 3 FS5	SECTOR 4 FS6	SECTOR 5 FS7	SECTOR 6 FS8	SECTOR 7 FS9	SECTOR 8 FS10	24V FS11 (QB)
2-Zone panel	3.15A	3.15A	750mA	750mA							500mA
4-Zone panel	3.15A	3.15A	750mA	750mA	750mA	750mA					500mA
8-Zone panel	3.15A	3.15A	750mA	750mA	750mA	750mA	750mA	750mA	750mA	750mA	500mA
Repeat panel	3.15A	3.15A									
Fuse marking	T3.15AH250V (SB) - Slow blow ceramic										500mA250V

All other fuses, ie FS1, FS2 and FS11 are 20mm x 5mm diameter  
QB - Quick Blow AS - Anti-Surge SB - Slow Blow (ie Time Delay)

All sector outputs have resettable 0.75A fuses which do not need replacing. The individual outputs will recover after removing the fault. The recovery time is 30 seconds minimum and it is recommended that the sectors be switched off (Silence Alarms).

Figure 12 Panel terminals and fuses

**Controls & indicators**

**CONTROLS** - only available when an access code is entered.

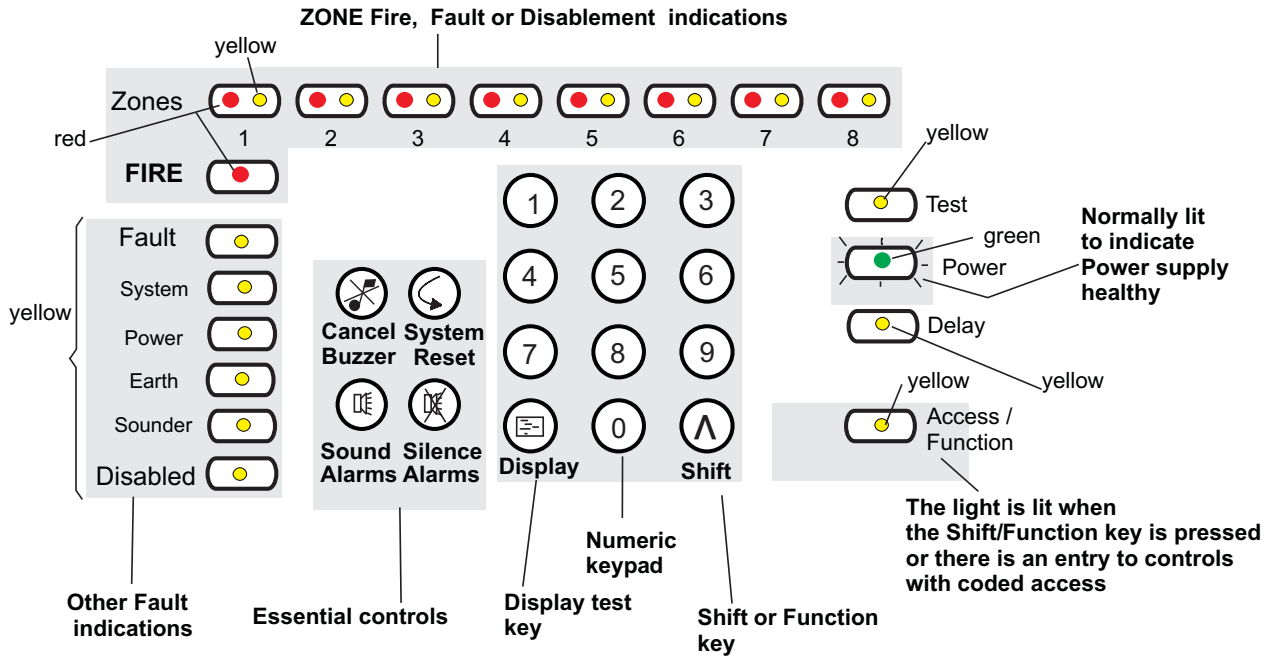

Figure 13 Controls and indications

**Numeric keypad.** Allows the entry of numeric data.

- Shift key.** The Shift/Function key gives access to the main functions of the panel.
- Display test key.** Pressing the Display Test key after entering access code# will initiate a sequence which illuminates all the indicators in turn enabling them to be checked.

# Coded entry is only required if Cancel Buzzer and Display Test functions are configured for operation at Access level 2.

- Cancel Buzzer.** Pressing the Cancel Buzzer button after entering access code# will stop the internal buzzer sounding.
- System Reset.** The system reset key when pressed after entering access code will return the system to its normal operating state. If there are uncleared fires or faults then these conditions will re-occur.
- Sound Alarms.** Pressing the Sound Alarms button after entering access code will sound all of the system alarms. Should only be pressed in an

emergency or at other agreed times, ie for sounder tests etc. Pressing the sound alarms button does not action the auxiliary relay.

- Silence Alarms.** Pressing the Silence Alarms button after entering access code will silence the system alarms. Should only be pressed when the emergency is over.

**Indicators.**

- Fire.** When lit indicates that the system has detected a fire.
- Fault.** When lit or flashing indicates that there is a fault condition on the system which requires rectification.
- Zone Fire/Fault/Disablement.** Red indicator illuminates when there is a zone fire, it can be a steady or flashing indication. For a zone fault the yellow indicator is flashing. A lit zone yellow indicator along with the Disabled indicator is used to show a disabled zone.
- System Fault.** This indicator when lit indicates that there is a fault in the panel's processor.

- Power Fault.** When lit or flashing indicates that there is a power supply fault present.
- Earth Fault.** This indicator when lit or flashing indicates that there is an Earth Fault on the system.
- Sounder Fault.** When flashing in conjunction with a flashing fault indicator indicates a sounder fault. When lit in conjunction with the disabled indicator indicates that the sounders are disabled.
- Disabled.** Illuminates along with the sounder or the zone indicators to show a disabled condition.
- Test.** When lit indicates that the panel is in Test mode.
- Power.** When lit indicates that the panel is powered up.
- Delay.** When lit it indicates that a delay will be effective after detection of a fire before activation of system alarms.
- Access/Function.** The Access/Function lamp will flash when the shift key is pressed and will be lit when the coded functions are accessed.

### Power up tests

Connecting the battery will not power up the panel, power up will occur after mains is applied.

The total system should be tested in accordance with the commissioning requirements of *BS5839:Part 1:2002 + A2:2008* or other standard specified by the system purchaser.

**NOTE:** The commissioning procedures assume that the system has been installed as per instructions in this booklet.

#### Checks before power up

- Ensure you have 'as fitted drawings'
- check the system has been installed to the project requirements.
- if necessary, action the installer to carry out rectification work.

#### Initial power up

- a) Disconnect cables to terminals of zone, sounder, class change, auxiliary, common fire and fault circuits. Ensure each cable is marked for reconnection to respective terminals later.
- b) Connect end-of-line capacitor units to zones and end-of-line resistor units to sounder circuits for initial power up.
- c) Check mains connection and switch on the mains power to the control panel.
- d) Now connect the battery supply, see *Figure 14*.
- e) Check the panel provides a normal healthy indication, with the green light lit.

#### Zone circuit tests

- a) Transfer the end-of-line capacitor unit to the last device (detector or manual call point) on a zone circuit.
- b) Connect a zone cable to the terminals of a zone circuit.
- c) Carry out zone open circuit and short circuit tests and check appropriate indications are given.
- d) Repeat the above for other zone circuits.

#### Sounder circuit tests

- a) Transfer the end-of-line resistor unit to the last device on a sounder circuit.
- b) Connect a sounder circuit cable to a sounder circuit terminals.
- c) Carry out sounder open and short circuit tests and check appropriate indications are given.
- d) Repeat the above for other sounder circuits.

#### EEPROM Protection link

**NOTE:** Ensure that the EEPROM protection link is fitted to connector P8, see *Figure 14*.

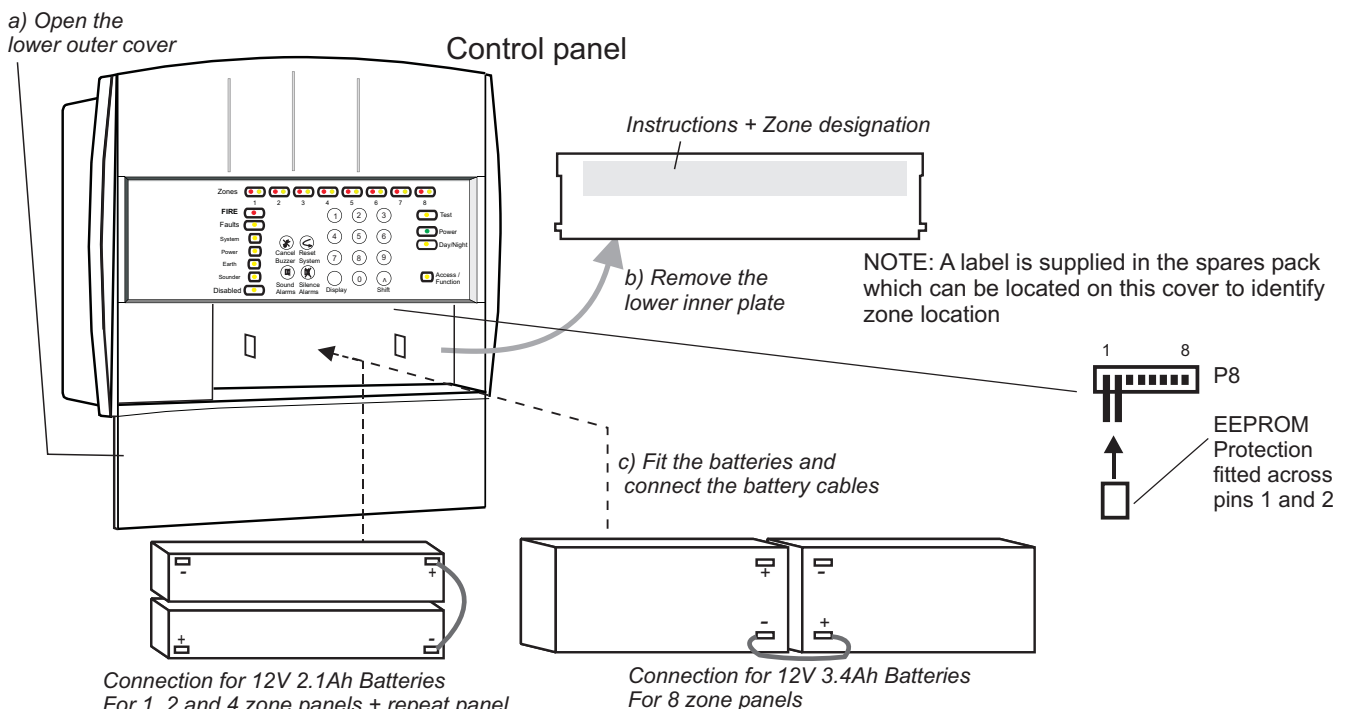

Figure 14 Battery installation and EEPROM protection link

**Installed system tests**

The fire detection and alarm system should be tested to ensure it operates to meet the standards and project requirements.

**Configuration**

The control panel is factory set to the requirements of EN54 Parts 2 and 4.

With **Test mode A or B** active: a triggered manual call point or fire detector in the test zone will give:

<b>Test A</b>	Fire indication for 10 seconds duration followed by a system reset
<b>Test B</b>	System alarm sounds for the first 2 seconds and at the same time a Fire indication is given for 10 seconds duration followed by a system reset

Table 2 Test mode operation

The operation of the control and repeat panels and the system may be re-configured to site specific needs.

To facilitate tests on the fire detection and alarm system the control panel can be set to operate in a test mode. Note a detector that is still full of smoke or heat will retrigger into a fire condition until the smoke or heat in the area is cleared.

**Sound level test**

Sound level tests should be conducted to standard requirements and to customer satisfaction.

**Other equipment tests**

Where external equipment is connected to the control panel using auxiliary, common fire and fault terminals, then these must be tested to project requirements.

**Zone designation label**

- a) Write on to the zone designation label the name that identifies the area protected by each zone circuit.
- b) Fix the label over the zone designation part of the lower inner plate, see *Figure 14*.

**Log book**

Fill in the system details on the first three pages of the log book.

**On completion**

Ensure the persons responsible for the system are made aware of:

- system operation
- access codes to controls
- basic controls
- their responsibility
- and the need to log system events in the log book.

Condition	Visual indications					Signals out		
	Zone Fire (1-8) -Red	Zone Fault (1-8) - Yellow	Test - Yellow	Power - Green	Access/Function - Yellow	Aux Relay contacts Normally de-energised	Common fault - Normally active	Common fire- Normally deactive
Test A or B (Normal)		On	On	On	On	Normal	Active	Deactive
Test A (Fire)	On	On	On	On		Normal	Active	Deactive
Test B (Fire)	On	On	On	On		Normal	Active	Deactive

Test condition indications

**Config. considerations**

**Repeat panel config.**

- The power up procedure for the repeat panel is the same as the main panel.
- The presence of a repeat panel needs to be set up at the main panel, see Config. and Test section.

**Delay mode**

In the Delay mode there is a delay between detecting a fire and sounding the alarms to enable the fire to be investigated. The panel will upon detection of a fire:

- Illuminate the Common fire and appropriate zone fire lamps.
- Cause the panels internal buzzer to emit the fire tone.
- Activate the common fire and auxiliary outputs.
- Delays the activation of the sounders for a configurable delay of between 1 and 10 minutes in 1 minute steps.

If the panel is reset during the delay period, the delay is cancelled. Also if another fire occurs in a different zone to the first fire, the alarms will activate immediately. You can override the delay and activate all sounders in

the system by operating the *Sound Alarms* button.

**False alarm rejection**

- This is an enhanced fire alarm rejection algorithm designed to give greater immunity to spurious alarms.
- The Fire alarm rejection algorithm should only be used in conjunction with recommended detectors to guarantee that the system will reject spurious events but will detect and annunciate real fires within 10 seconds, which is an EN54-part 2 requirement. When set, the algorithm applies to ALL zones on the panel.

## Access levels 2

To configure the system enter the appropriate access code.

**NOTE:** It is only necessary to enter the access code once, provided the 2 minute timeout is not exceeded between button presses.

### Access codes

Factory set codes are:  
Access level 2 Code : 123

Depending on how the system is configured coded entry may be necessary for test.

The factory codes can be changed at any time after power up.

**NOTE:** It is important to leave the system in a normal operating condition on completion of commissioning.

**NOTE:** The auxiliary contacts do not operate in the Test Modes.

## Operating Instructions for AL2 functions

### How to do a Display test

- Enter the AL2 access code and check that the Access/function lamp is lit.
- Press the **shift** and **display** buttons and check that all indicators are lit.

### How to set the panel to operate in Test mode A

- Enter the AL2 access code and check that the Access/function lamp is lit.
- Press the **shift** and **3** buttons followed by the number of the zone to be placed in test mode.
  - Check that the Test indicator is On and the zone fault indicator is lit.
  - The zone can be tested without an alarm of fire

### How to set the panel to operate in Test mode B

- Enter the AL2 access code and check that the Access/function lamp is lit.
- Press the **shift** and **4** buttons followed by the number of the zone to be placed in test mode.
  - Check that the Test indicator is On and the zone fault indicator is lit.
  - The zone can be tested with 2 seconds alarm of fire.

### How to cancel Test mode A/B

- Enter the AL2 access code and check that the Access/function lamp is lit.
- Press the **shift** and **5** buttons followed by the number of the zone to have test mode cleared.
  - The test mode A or B is cancelled.

### How to disable a zone

- Enter the AL2 access code and check that the Access/function lamp is lit.
- Press the **shift** and **1** buttons followed by the number of the zone to be disabled.
  - Check that the appropriate Zone fault indicator and the Disabled indicator are lit.
  - A detected fire in the disabled zone will not cause the panel to go into fire condition.

### How to enable a zone

- Enter the AL2 access code and check that the Access/function lamp is lit.
- Press the **shift** and **2** buttons followed by the number of the zone to be re-enabled.
  - The previously disabled zone is re-enabled.

### How to disable sounders

- Enter the AL2 access code and check that the Access/function lamp is lit.
- Press the **shift** and **1** buttons followed by **0**.
  - Check that the Sounder and Disabled indicators are lit.
  - The Sounder circuits are disabled.

**How to disable sounders**

- Enter the AL2 access code and check that the Access/function lamp is lit.
- Press the **shift** and **1** buttons followed by **0**.
  - Check that the Sounder and Disabled indicators are lit.
  - The Sounder circuits are disabled.

**How to enable sounders**

- Enter the AL2 access code and check that the Access/function lamp is lit.
- Press the **shift** and **2** buttons followed by **0**.
  - The previously disabled sounders are now re-enabled.

**How to set and unset the Delay mode**

- Enter the AL2 access code and check that the Access/function lamp is lit.
- Press the **shift** and **6** buttons.
  - The **Delay mode** toggles between Delay and No Delay each time this operation is performed. When Delay mode is selected the Delay lamp is lit.

**How to exit from AL2, AL3 or AL4 to AL1**

- Press the **shift** button followed by **0**.
  - Check that the Access/function lamp is extinguished.
  - The panel is now in access level AL1.

**How to change password or PIN****How to change AL2 password**

- Enter the AL3 access code and check that the Access/function lamp is lit, see page 14 for AL3 password.
- Press the **shift** and **9001** buttons in sequence and check that the System LED is flashing
- Input the new AL2 access code.

**How to change AL3 password**

- Enter the AL3 access code and check that the Access/function lamp is lit.
- Press the **shift** and **9002** buttons in sequence and check that the System LED is flashing
- Input the new AL3 access code.

## Programming Options

**NOTE:** There is a 2 minute timeout on the access levels. If this period is exceeded the code will have to be re-entered.

In order to access the EEPROM, the EEPROM protection link needs removing, see Figure 14.

The default settings of the panel may be changed to suit site requirements.

### Factory set codes:

**AL3 code is: 321**

This is the code on first power-up and it can be changed at any time.

**AL4 code is: 7426**

This code is for the use by the servicing organisation only.

There is a reset code, 2623 which will reset the AL2 and AL3 codes to their factory settings.

Whilst the EEPROM is unprotected during programming, the system fault light will flash to indicate that the EEPROM

protection link is removed. If further changes are required, the sequence shift followed by 9000 must be re-entered.

Once the changes have been made, the panel must be powered down and then powered up again for the changes to take place.

**NOTE:** After programming is complete the EEPROM protection link must be refitted.

## Operating instructions for Access level 3 functions

### To allow Cancel buzzer at access level 1 (default setting)

Enter 3 digit AL3 access code (default = 321), Press Shift, Enter data 9000 000 000

### To allow Cancel buzzer at access level 2

Enter 3 digit AL3 access code (default = 321), Press Shift, Enter data 9000 000 001

### To allow Display test at access level 1

Enter 3 digit AL3 access code (default = 321), Press Shift, Enter data 9000 001 001

### To allow Display test at access level 2 (default setting)

Enter 3 digit AL3 access code (default = 321), Press Shift, Enter data 9000 001 002

### To allow Test condition at access level 2 (default setting)

Enter 3 digit AL3 access code (default = 321), Press Shift, Enter data 9000 002 002

### To allow Test condition at access level 3

Enter 3 digit AL3 access code (default = 321), Press Shift, Enter data 9000 002 003

### To allow most recent fire alarm indication as a steady state indication (default setting)

Enter 3 digit AL3 access code (default = 321), Press Shift, Enter data 9000 003 000

### To allow most recent fire alarm as a pulsing indication

Enter 3 digit AL3 access code (default = 321), Press Shift, Enter data 9000 003 001

### To allow Auxiliary output to activate in fire and deactivate on reset (default setting)

Enter 3 digit AL3 access code (default = 321), Press Shift, Enter data 9000 005 000

### To allow Auxiliary output to activate in fire and deactivate on reset and silence alarms

Enter 3 digit AL3 access code (default = 321), Press Shift, Enter data 9000 005 001

### To change the Delay mode setting (default setting is 1 minute)

Enter 3 digit AL3 access code (default = 321), Press Shift, Enter data 9000 006 and data 000 to 010 in minutes. **Note if a value of greater than 10 minutes is entered, it will be truncated to 10 minutes.**

**CAUTION:** These AL3 functions are for use by trained persons on site who are responsible for the fire alarm system.

**To allow False Alarm Rejection On/Off (default is Off)**

- Enter 3 digit AL3 code (default = 321), press shift, Enter 9000 007 followed by 000 to turn the false alarm rejection algorithm Off.
- Enter 3 digit AL3 code (default = 321), press shift, Enter 9000 007 followed by 001 to turn the false alarm rejection algorithm On.

**To enter number of connected Repeat panels (default setting is 0) - TO BE SET AT MAIN PANEL**

- Enter 3 digit AL3 access code (default = 321), Press Shift, Enter data 9000 009 001

**Operating instructions for Access level 4 functions**

**CAUTION: These AL4 functions are for trained engineers only and normally access to these functions is NOT required.**

**How to set Non Latching Zone configuration (default setting is all zones are latching)**

- A non latching zone fire condition will not action the auxiliary relay.  
Enter 4 digit AL4 access code (7426), Press Shift, Enter data 9000 032 and data as follows:  
Decimal equivalent of **eight bit number** where a '1' signifies a latching zone and a '0' signifies a non latching zone, also bit 0 corresponds to zone 1 and bit 7 corresponds to zone 8.

E.g. Requirement	eight bit number	data
All Zones non latching	00000000	000
Zone 1 latching, all others non latching	00000001	001
Zones 3,5,6 latching, all others non latching	00110100	052
All Zones latching	11111111	255

**How to set Reset Silence Configuration (default silence alarms before reset)**

- Enter 4 digit AL4 access code (7426), Press Shift, Enter data 9000 033 followed by 000 for a Reset Silences and 001 for UK Linking.

**How to set Sound/Resound alarms configuration (default is sound alarms at any time)**

- Enter 4 digit AL4 access code (7426), Press Shift, Enter data 9000 034 followed by 000 for a Sound Alarms at any time and 001 for Resound only.

**How to set Zone short circuit configuration (default is short circuit seen as fault)**

- Enter 4 digit AL4 access code (7426), Press Shift, Enter data 9000 035 data as follows:  
Decimal equivalent of **eight bit number** where a '1' signifies a zone short circuit being seen as a fire and a '0' signifies a zone short circuit being seen as a fault, also the bit 0 corresponds to zone 1 and bit 7 corresponds to zone 8.

E.g. Requirement	eight bit number	data
For all Zones - short circuit signifies a fault	00000000	000
Zone 1 - short circuit signifies a fire	00000001	001
Zones 3,5&6 - short circuit signifies a fire	00110100	052
All Zones - short circuit signifies a fire	11111111	255

**How to set the number of zones used (default is 8 zone)**

- Enter 4 digit AL4 access code (7426), Press Shift, Enter data 9000 036 followed by data as follows:  
001 for One zone panel, 002 for Two zone panel, 004 for Four zone panel and 008 for Eight zone panel.

**How to change Charger Output level (default is 128)**

- Enter 4 digit AL4 access code (7426), Press Shift, Enter data 9000 037 followed by a number between 000 and 255.

**How to change the Reset Duration (default is 010)**

- Enter 4 digit AL4 access code (7426), Press Shift, Enter data 9000 038 followed by a number between 000 and 100, in tenths of a second.

**How to return all settings to Factory default (from custom settings)**

- Enter 4 digit AL4 access code (7426), Press Shift, Enter data 9000 007 followed by a number 999.

### Fault indications

**All fault repairs should be carried out by the servicing organisation.**

In a fault condition:

- the common Fault light is lit
- appropriate Fault light is also lit
- internal Fault Buzzer sounds intermittent tone
- Multiple faults are simultaneously annunciated when this does not cause confusion.

**NOTE:** Normally the fault lights will be automatically extinguished once the fault condition is rectified.

**NOTE:** If the system detects a fire during a fault condition the fault indicators may be extinguished.

### How to silence the fault buzzer

- Press the 3 digit code, if required and then press Cancel Buzzer.

- Notice the buzzer is silenced but visual indications remain active.

**NOTE:** The sounder circuits are pulse monitored for failure.

Faults	Cause
What is a Zone fault?	A zone fault occurs when a zone circuit cable is open circuit or short circuit, or the end-of-line capacitor unit has been disconnected or a detector has been removed.
What is a Sounder fault?	A sounder fault occurs when a sounder circuit cable is open circuit or short circuit, or the end-of-line resistor unit has been disconnected.
What is a Mains power fault?	A mains failure occurs when the mains power supply to the panel is removed. This can occur on mains fuse failure or mains supply disconnection.
What is a Battery power fault?	A battery supply failure occurs when the battery supply to the panel has failed (due to aging process) or battery voltage is too low or is disconnected or the battery fuse has failed.
What is an Earth fault?	An earth fault occurs when there is an electrical path for current flow from the system to earth connections.
What is a Repeat panel fault?	A Repeat Panel fault occurs when a fault is detected within the Repeat Panel
What is a Repeat panel link fault?	A repeat panel link fault occurs when there is a communication failure between the control and repeat panels or if the link has been removed or damaged.
What is a System Fault?	A system fault occurs in the event that the microprocessor or software fails.
What is a charger fault?	A charger fault occurs when the charger will not switch off or will not provide charge when on.
What is a power fault?	A power fault occurs when there is an incorrect 24V level or fuse failure. Also occurs if the sounder output supply is at the incorrect level or overloaded during alarm condition.

Table 3 Types of faults

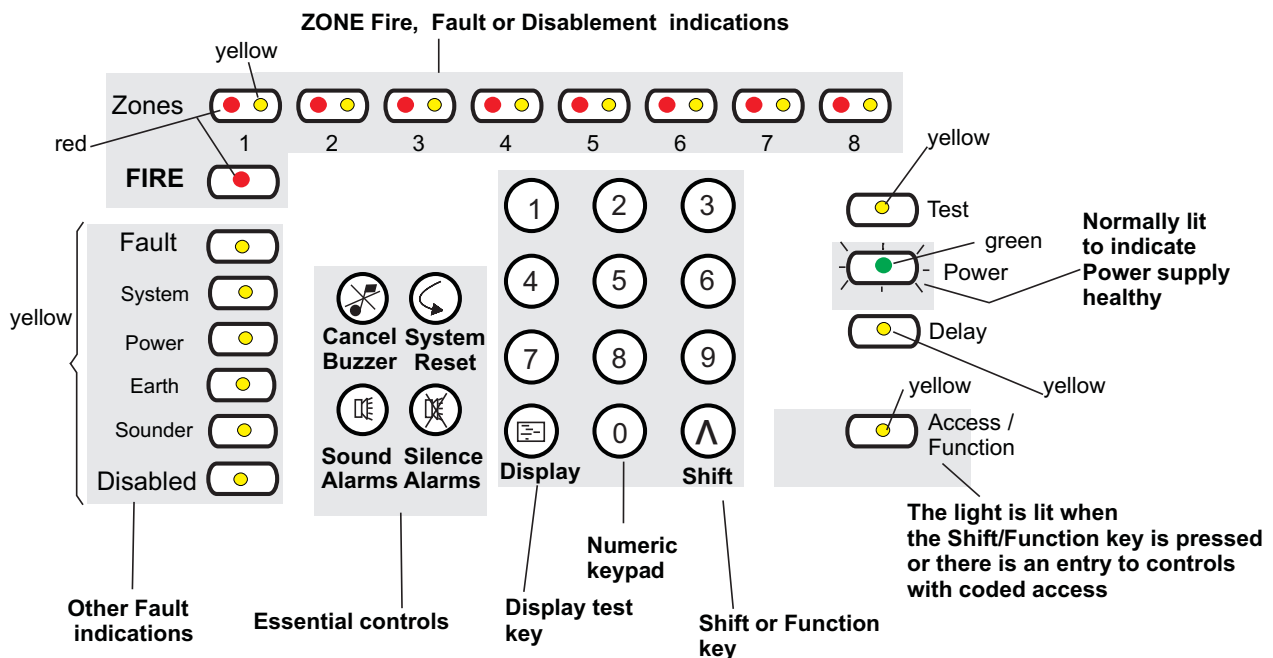
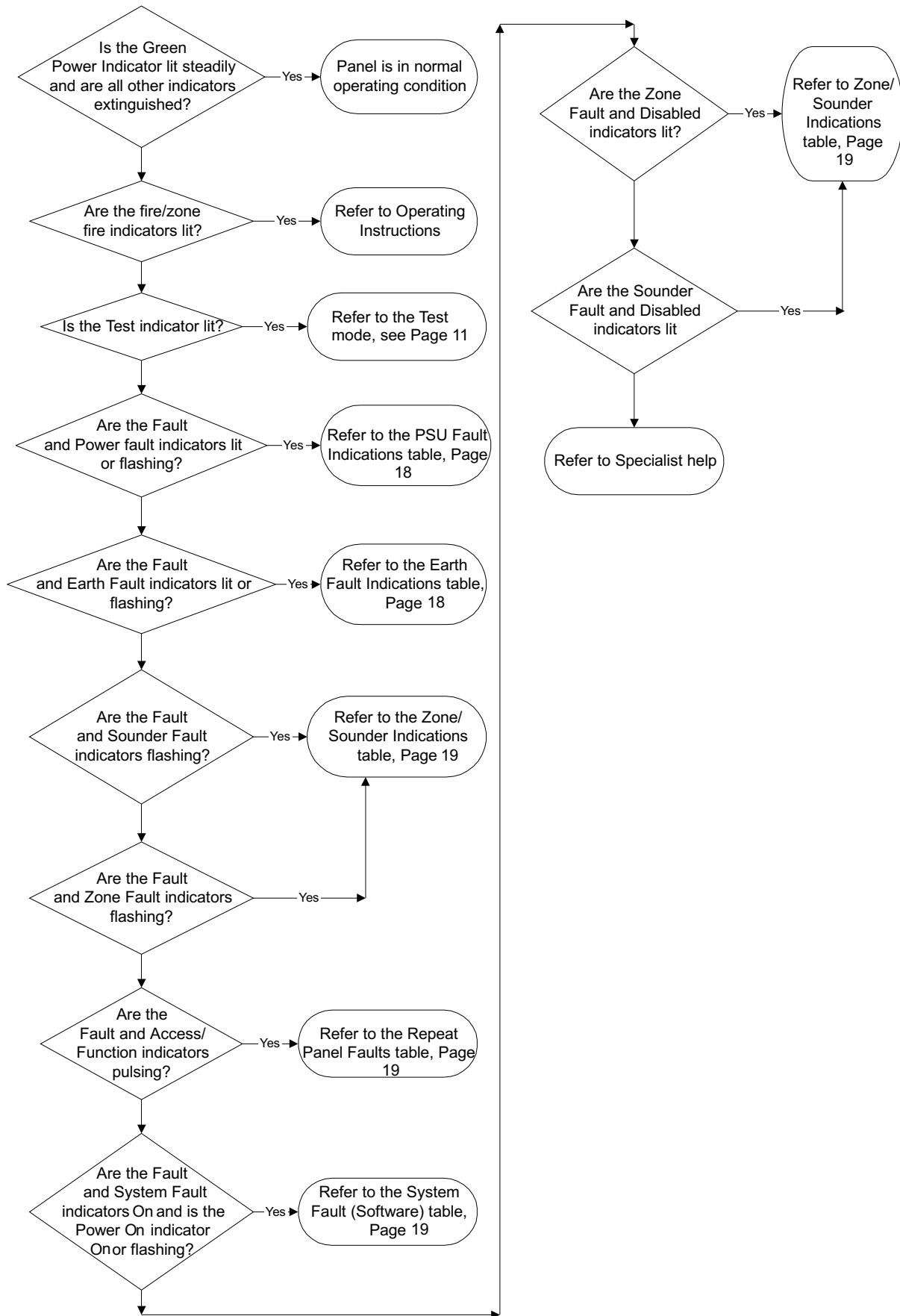

Figure 15 Fault indicators

**Fault finding**



**PSU Fault Indications**

**At Main Panel**

Green Power Indicator	Power Fault Indicator	Meaning
Steady	Off	No PSU Faults
Slow Flash	Slow Flash	Mains failed (Common Fault indicator also flashes to save batteries*)
Slow Flash	Fast Flash	Battery disconnected/Battery fault or Charger fault
Slow Flash	Steady	Auxiliary supply/sounder output supply fault

\* If Access/Function indicator flashes slowly, there is either a comms fault, an earth fault or a PSU fault on the Repeat Panel.

**At Repeat Panel**

Green Power Indicator	Power Fault Indicator	Meaning
Steady	Off	No PSU Fault in either Main Panel or Repeat panel
Steady	Slow Flash	Mains failed at Main Panel
Steady	Fast Flash	Battery disconnected/Battery fault/Charger fault at Main Panel
Steady	Steady	Auxiliary supply/sounder output supply fault at Main Panel
Slow Flash	Slow Flash	Mains failed at Repeat Panel
Slow Flash	Fast Flash	Battery disconnected/Battery fault/Charger fault at Repeat Panel

\* If Access/Function indicator flashes slowly, there is a comms fault, between the Main Panel and the Repeat Panel.

**NOTE:** If there is a PSU fault at the Main Panel and the Repeat Panel, then priority is given to the fault at the Main Panel

**Earth Fault Indications**

**At Main panel**

	Fault - Yellow	Earth - Yellow	Power - Green	Buzzer	Auxiliary relay contacts normally de-energised	Common fault - normally active	Common fire - normally deactive
Earth fault indications	Steady	Pulse Slowly	On	Pulse Slowly	Normal	Deactive	Deactive

**NOTE:** If a Repeat panel is connected, the ACCESS/FUNCTION lamp will pulse slowly as well.

**At Repeat Panel**

<b>Earth Fault Indicator</b>	Off	No earth fault at the Repeat Panel or the Main Panel
	Steady Indication	Earth fault local to the Main Panel

**Zone/Sounder Indications**

Condition	Visual Indications					Audible Indications	Signals out		
	Zone Fault (1-8) - Yellow	Fault - Yellow	Sounder - Yellow	Disabled - Yellow	Power - Green		Aux Relay contacts Normally de-energised	Common fault - Normally active	Common fire- Normally deactive
Zone fault	Pulse slowly	Steady			On	Pulse slowly	Normal	Deactive	Deactive
Sounder fault		Steady	Pulse slowly		On	Pulse slowly	Normal	Deactive	Deactive
Disable zone	On			On	On		Normal	Active	Deactive
Disable Sounder			On	On	On		Normal	Active	Deactive

**Repeat Panel Fault Indications**

Condition	Visual indications			Audible indication	Signals out		
	Fault - Yellow	Power - Green	Access/ Function - Yellow		Aux Relay contacts Normally de-energised	Common fault - Normally active	Common fire- Normally deactive
Repeat Panel Link Fault	Steady	On	Pulse slowly	Pulse slowly	Normal	Deactive	Deactive

**System Fault (Software) Indications**

Condition	Visual indications			Audible indication	Signals out		
	Fault - Yellow	System - Yellow	Power - Green		Aux Relay contacts Normally de-energised	Common fault - Normally active	Common fire- Normally deactive
Software system fault	On	On	On (Pulses at Repeat panel)	On	Normal	Deactive	Deactive

## Specification for the Control panel

Note: Batteries are not supplied with some panels

Number of Zone (detection) circuits	1 - Zone panel	2 - Zone panel	4 - Zone panel	8 - Zone panel
Zone circuit voltage range	19V to 25.5V			
Zone circuit load (maximum)	Maximum Quiescent current: 3.0mA per zone OR EN54 compliance limitation: 32 devices OR Maximum of 20 diode bases per zone (Short circuit current limited to < 20mA)			
Number of Sounder circuits	2	2	4	8
Sounder circuit (shared load)	0.5A per output, 1A max shared load @ 24V +2V -2V with mains present (24V +2V -4V battery only)			
Sounder circuit fuse	0.75A resettable			
End-of-line unit	<b>Zone circuit:</b> Capacitor (diode) unit <b>Sounder circuit:</b> 10K ohms resistor OR Bipolar Capacitor			
Flush fixing kit	13270-29 (Cut out required 378mm wide x 245mm high x 60mm deep)			
Colour	Front cover - Grey RAL 7000 (standard)			
Assembled panel size (in mm)	395 wide x 274 high x 87 deep			
Weight (with batteries) approximate	5.8kg	5.8kg	5.8kg	6.2kg
Operating temperature and humidity	0 - 40°C low to +95% RH non condensing			
Storage temperature and humidity	-5°C to +50°C low to +95% RH condensing			
Standards	EN54-2: 1997, A1:2006 plus EN54-4: 1997, A1:2002, A2:2006			
Approvals	BSI approval acquired			
Emission	BS EN50081-1:1992: Part 1 Residential, Commercial & Light industry <b>Class B limits</b>			
Immunity	BS EN50130-4: 1996: Part 4 Alarm systems : Electromagnetic compatibility Product family standard: <i>Immunity requirements for components of fire, intruder and social alarm systems</i>			
IP rating (BS5490)	IP31 (indoor)			
Knock-In cable entry points	13 - top & 13 - back			
Terminal size	2.5mm <sup>2</sup> maximum			
Battery standby with 1mA load per zone and 1A total sounder alarm load	72hr standby plus 0.5hr with alarm load			
Auxiliary contacts (operates with fire)	Pair of normally closed (NC) and a pair of normally open (NO) contacts rated 1A @ 24V dc resistive load (Maximum <b>100m</b> cable distance)			
Common Fault	Open collector - normally <b>On</b> (35mA limit)			
Common Fire	Open collector - normally <b>Off</b> (16mA limit)			
Class change	Normally open push button, up to <b>100m</b> cable distance away from the panel			
24V Power supply (Monitored)	250mA maximum at 24V dc +2V, -4V		500mA maximum at 24V dc +1.5V, -4V	
User access: By means of code entry via numeric key pad (AL1 Authorised user - No code is required)	AL2 Site security 3 digit code - <b>123</b> AL3 Site engineering 3 digit code - <b>321</b> AL4 Engineers 4 digit code - <b>7426</b> Reset AL2 & AL3 codes 4 digit code - <b>2623</b>			
Key pad button controls	Sound alarm, Silence alarm, System Reset & Cancel buzzer & numeric keypad.			
Buzzer for local audible indications	Fire & System Fault - continuous sound Fault - intermittent sound (via piezoelectric buzzer operating at 2 or 2.5KHz 70dB(A) at 1m)			
Visual indications	FIRE & ZONES-fire ( <b>Red LEDs 'lights'</b> ) ZONES-fault, Fault, System, Power, Earth, Sounder, Disable, Test, Power, Access/Function ( <b>Yellow LEDs 'lights'</b> ) Power on ( <b>Green LED 'lights'</b> ) Delay ( <b>Yellow LED 'lights'</b> )			
Repeat panel connections	via serial port, see also repeat panel specification			

**Specification for control panel's Power supply**

The control panel consists of single board containing both the control and indicating equipment and the power supply. A 50VA mains transformer provides a low voltage (30Vac) supply into the power supply circuits. The on board power supply circuits produce a regulated 24V dc supply, a 24V sounder supply and a battery charger output.

Note the control and monitoring of the power supply unit is under direct control of the microprocessor of the control and indicating equipment.

<b>Mains supply</b>	
Mains	230V -15% +10% 50Hz/60Hz Fused at 3.15A Ceramic Time delay Typical standby power 6W Maximum alarm power <60W (8 zone panel)
<b>Internal supply</b>	
24V supply (Feeds current limited zone circuit & 24V fused output)	24V dc +2V -2V (or 24V +2V -4V battery operation) current limited <5% ripple voltage
24V Sounder supply (Feeds fused sounder circuit)	24V dc +2V -2V (24V +2V -4V battery operation) Current limited <5% ripple voltage
Battery Charger	Float voltage 27.3V +1% -1% @ 20degC Compensation -36mV/K (nominal) Current limited @ 400mA +20% -20% Fused @ 3.15A Ceramic Time delay Reverse protection

Use the Battery Standby Calculator sheet available from 'www.gentexpert.co.uk' to determine the site specific battery standby capability of the system.

<b>Battery supply</b>	
Approved Batteries	12V, 2.1Ah POWERSONIC 12V 3.4Ah POWERSONIC
Type and capacity	Sealed lead acid (value regulated) 2x12V, 2.1Ah min to 3.4Ah* max (1,2&4 zone panels) 2x12V, 3.4Ah*max (8 zone panel) * max capacity limited by internal panel size
Maximum current	1.6A (no mains present)
Final voltage	21.6V
Installation requirements	As per control panel
EN54 Part 4 data	I min -> 120uA I maxa -> 21.6mA I maxb -> 1.5A Ri max-> 2Ω UVLO -> 18.5V ± 1.5V

## Specification for the Repeat panel

Number of Zones	8 - Zone (standard size)
Colour	Front cover - Grey RAL 7000
Assembled panel size (in mm)	395 wide x 274 high x 87 deep
Weight (with batteries) approximate	5.8kg (2.1Ah battery) / 6.2Kg (with 3.4Ah battery)
Operating temperature and humidity	0 - 40°C low to +95% RH non condensing
Storage temperature and humidity	-5°C to +50°C low to +95% RH condensing
Approvals	Not applicable
Emission	BS EN50081-1:1992: Part 1 Residential, Commercial & Light industry <b>Class B limits</b>
Immunity	BS EN50130-4: 1996: Part 4 Alarm systems : Electromagnetic compatibility Product family standard: <i>Immunity requirements for components of fire, intruder and social alarm systems</i>
IP rating (BS5490)	IP31 (indoor)
Flush fixing kit	13270-29 (Cut out required 378mm wide x 245mm high x 60mm deep)
Mains operating voltage	230V ac +10% -15% 50Hz
Knock-In cable entry points	Top & back entries
Terminal size	2.5mm <sup>2</sup> maximum
Battery supply (sealed lead acid)	2-off12V 2.1Ah - 3.4Ah (See applicable batteries as listed for Control panel)
Standby duration	72hr standby
User access: By means of code entry via numeric key pad (AL1 Authorised user - No code is required)	AL2 Site security 3 digit code - <b>123</b> AL3 Site engineering 3 digit code - <b>321</b> AL4 Engineers 4 digit code - <b>7426</b> Reset AL2 & AL3 codes 4 digit code - <b>2623</b> <i>NOTE: Only a limited number of functions are accessible at the repeat panel.</i>
Key pad button controls	Sound alarm, Silence alarm, System Reset & Cancel buzzer & numeric keypad.
Buzzer for local audible indications	Fire & System Fault - continuous sound Fault - intermittent sound (via piezoelectric buzzer operating at 2 or 2.5KHz 70dB(A) at 1m)
Visual indications	FIRE & ZONES-fire ( <b>Red LEDs 'lights'</b> ) ZONES-fault, Fault, System, Power, Earth, Sounder, Disable, Test, Power, Access/Function ( <b>Yellow LEDs 'lights'</b> ) Power on ( <b>Green LED 'lights'</b> ) Delay ( <b>LED 'lights'</b> )
Repeat panel (standard 8 zone)	A maximum of 1 repeat panel can be connected in series with the control panel
Repeat panel connections	via serial port

## Parts list



### Panels

Part number	Description
# - less batteries	
13270-02LB	2 Zone control panel #
75585-02NMB	2 Zone control panel #
13270-04LB	4 Zone control panel #
75585-04NMB	4 Zone control panel #
13270-08LB	8 Zone control panel #
75585-08NMB	8 Zone control panel #
13271-08LB	Repeat panel #
75586-08NMB	Repeat panel #
13270-29	Panel flush fixing kit

### Panel Accessories

Part number	Description
4015-502-Y	2 x 12V 2.1Ah battery (for 1, 2 & 4 zone panel plus repeat panel)
4015-509-Y	2 x 12V 3.4Ah battery (for 8 zone panel)
XEN-FFR	Fire fault relay unit

Consult the supplier for information on compatible detectors, manuals call points and alarm devices for installation on external circuits.

 0832	 2797																																
Gent by Honeywell Manufactured by: Honeywell Life Safety Systems-Romania, Street Str, Salcamilor 2 bis-Lugoj																																	
<b>13</b>																																	
<table style="width: 100%; border-collapse: collapse;"> <thead> <tr> <th style="text-align: left;">DoP</th> <th style="text-align: left;">Product No.</th> </tr> </thead> <tbody> <tr><td>053-CPR-2013</td><td>13270-01LB</td></tr> <tr><td>053-CPR-2013</td><td>13270-02LB</td></tr> <tr><td>053-CPR-2013</td><td>13270-04LB</td></tr> <tr><td>053-CPR-2013</td><td>13270-08LB</td></tr> <tr><td>2797-CPR-553764</td><td>75585-02NM</td></tr> <tr><td>2797-CPR-553764</td><td>75585-04NM</td></tr> <tr><td>2797-CPR-553764</td><td>75585-08NM</td></tr> </tbody> </table>	DoP	Product No.	053-CPR-2013	13270-01LB	053-CPR-2013	13270-02LB	053-CPR-2013	13270-04LB	053-CPR-2013	13270-08LB	2797-CPR-553764	75585-02NM	2797-CPR-553764	75585-04NM	2797-CPR-553764	75585-08NM	<table style="width: 100%; border-collapse: collapse;"> <thead> <tr> <th style="text-align: left;">DoP</th> <th style="text-align: left;">Product No.</th> </tr> </thead> <tbody> <tr><td>054-CPR-2013</td><td>13270-01SP</td></tr> <tr><td>054-CPR-2013</td><td>13270-02SP</td></tr> <tr><td>054-CPR-2013</td><td>13270-04SP</td></tr> <tr><td>054-CPR-2013</td><td>13270-08SP</td></tr> <tr><td>056-CPR-2013</td><td>75585-02RS</td></tr> <tr><td>056-CPR-2013</td><td>75585-04RS</td></tr> <tr><td>056-CPR-2013</td><td>75585-08RS</td></tr> </tbody> </table>	DoP	Product No.	054-CPR-2013	13270-01SP	054-CPR-2013	13270-02SP	054-CPR-2013	13270-04SP	054-CPR-2013	13270-08SP	056-CPR-2013	75585-02RS	056-CPR-2013	75585-04RS	056-CPR-2013	75585-08RS
DoP	Product No.																																
053-CPR-2013	13270-01LB																																
053-CPR-2013	13270-02LB																																
053-CPR-2013	13270-04LB																																
053-CPR-2013	13270-08LB																																
2797-CPR-553764	75585-02NM																																
2797-CPR-553764	75585-04NM																																
2797-CPR-553764	75585-08NM																																
DoP	Product No.																																
054-CPR-2013	13270-01SP																																
054-CPR-2013	13270-02SP																																
054-CPR-2013	13270-04SP																																
054-CPR-2013	13270-08SP																																
056-CPR-2013	75585-02RS																																
056-CPR-2013	75585-04RS																																
056-CPR-2013	75585-08RS																																
EN54-2: 1997 +A1:2006, EN54-4 :1997 +A1: 2002,A2 2006																																	
<table style="width: 100%; border-collapse: collapse;"> <tbody> <tr><td>13270-01LB (EN54-2 &amp; 4)</td><td>13270-01SP (EN54-2 &amp; 4)</td></tr> <tr><td>13270-02LB (EN54-2 &amp; 4)</td><td>13270-02SP (EN54-2 &amp; 4)</td></tr> <tr><td>13270-04LB (EN54-2 &amp; 4)</td><td>13270-04SP (EN54-2 &amp; 4)</td></tr> <tr><td>13270-08LB (EN54-2 &amp; 4)</td><td>13270-08SP (EN54-2 &amp; 4)</td></tr> <tr><td>75585-02NM (EN54-2 &amp; 4)</td><td>75585-02RS (EN54-2 &amp; 4)</td></tr> <tr><td>75585-04NM (EN54-2 &amp; 4)</td><td>75585-04RS (EN54-2 &amp; 4)</td></tr> <tr><td>75585-08NM (EN54-2 &amp; 4)</td><td>75585-08RS (EN54-2 &amp; 4)</td></tr> </tbody> </table>		13270-01LB (EN54-2 & 4)	13270-01SP (EN54-2 & 4)	13270-02LB (EN54-2 & 4)	13270-02SP (EN54-2 & 4)	13270-04LB (EN54-2 & 4)	13270-04SP (EN54-2 & 4)	13270-08LB (EN54-2 & 4)	13270-08SP (EN54-2 & 4)	75585-02NM (EN54-2 & 4)	75585-02RS (EN54-2 & 4)	75585-04NM (EN54-2 & 4)	75585-04RS (EN54-2 & 4)	75585-08NM (EN54-2 & 4)	75585-08RS (EN54-2 & 4)																		
13270-01LB (EN54-2 & 4)	13270-01SP (EN54-2 & 4)																																
13270-02LB (EN54-2 & 4)	13270-02SP (EN54-2 & 4)																																
13270-04LB (EN54-2 & 4)	13270-04SP (EN54-2 & 4)																																
13270-08LB (EN54-2 & 4)	13270-08SP (EN54-2 & 4)																																
75585-02NM (EN54-2 & 4)	75585-02RS (EN54-2 & 4)																																
75585-04NM (EN54-2 & 4)	75585-04RS (EN54-2 & 4)																																
75585-08NM (EN54-2 & 4)	75585-08RS (EN54-2 & 4)																																
<b>Intended for use in fire detection and fire alarm systems in and around buildings</b>																																	
Refer to DoP-053-CPR-2013, DoP-054-CPR-2013, DoP-055-CPR-2013, DoP-056-CPR-2013 for level or class of performance declared, for details see website <a href="http://www.gent.co.uk">www.gent.co.uk</a>																																	

	<p><b>At the end of their useful life, the packaging, product and batteries should be disposed of via a suitable recycling centre and in accordance with national or local legislation.</b></p>
---	---

	<p><b>WEEE Directive:</b>                  At the end of their useful life, the packaging, product and batteries should be disposed of via a suitable recycling centre.                  Do not dispose of with your normal household waste.                  Do not burn.</p>
---	--

Honeywell Gent reserves the right to revise this publication from time to time and make changes to the content hereof without obligation to notify any person of such revisions of changes.

	Honeywell Building Technologies, Building 5 Carlton Park, King Edward Avenue, Narborough, Leicester, LE19 0AL	Website: <a href="http://www.gent.co.uk">www.gent.co.uk</a>
	Telephone: +44 (0) 203 409 1779	Tech. Support: <a href="http://www.gentexpert.co.uk">www.gentexpert.co.uk</a>