

- Operating temperature range:**
-30°C to +65°C standard.
- Operating humidity range:**
20% to 90% RH continuous.
10% to 99% RH intermittent - non condensing.
- Operating pressure range:**
90 to 110 k Pa.
- Warm up time:**
20 minutes.
- Voltage range:**
2.9 V to 3.5 V bridge (at 200mA).
- Power consumption:**
700mW.
- Signal output:**
mV bridge.
- Calibration flow rate:**
recommended between 1 and 1.5 l/min.
- Poisoning:**
the sensing elements may become inactive after extensive exposure to silicones, halogenated hydrocarbons, heavy metals or sulphur compounds.
- Expected operating life:**
5 years.
- IP rating:**
IP65 standard.
IP67 with weather protection.

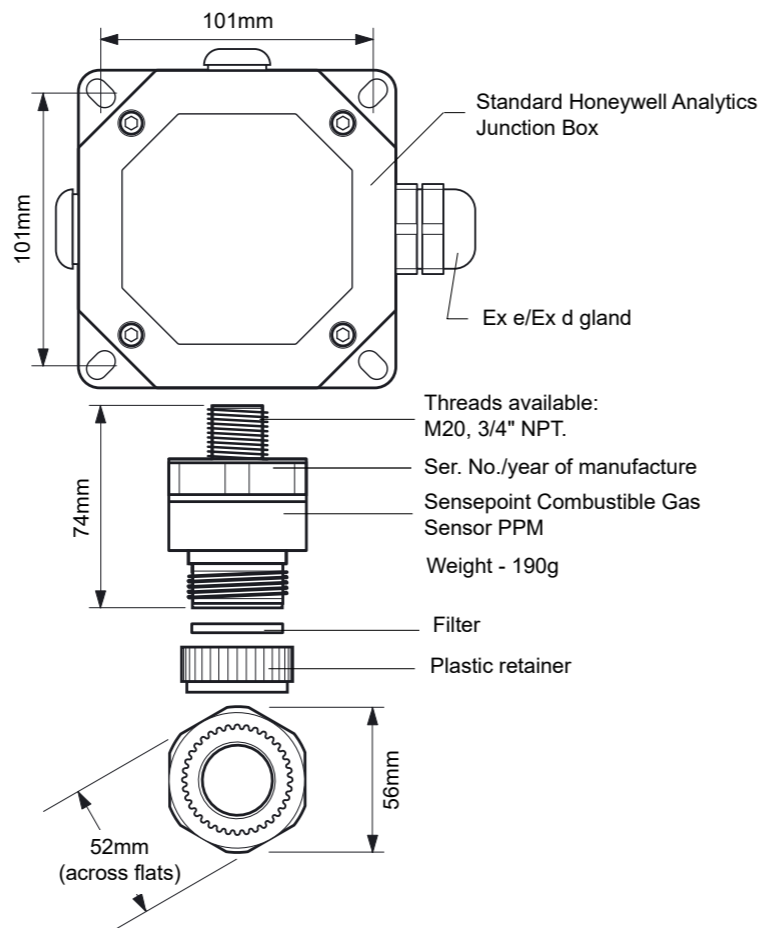

- Sensor2106B1205 (M20)
 - Sensor2106B1209 (3/4 NPT)
 - Weather protection.....02000-A-1640
 - Sensor filter.....00780-F-0018
 - Flow housing.....02000-A-1645
 - Collecting cone02000-A-1642
 - Junction box (std).....00780-A-0100
- To reorder a complete new sensor, see the label on the product leads, or contact Honeywell Analytics Ltd.

CERTIFICATION LABEL

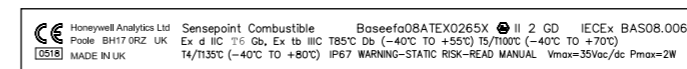

SAFETY



Sensepoint PPM Combustible Sensor

1. INTRODUCTION & 2. ASSOCIATED DOCUMENTATION

ATEX SPECIAL CONDITIONS FOR SAFE USE

- The detector must be protected from impact.
- The integral supply cables must be protected from impact and terminated in a suitable terminal facility.
- The detector is considered to present a potential electrostatic risk and must not be located in high air flows or rubbed.

1. INTRODUCTION

Sensepoint is a sealed disposable sensor for the detection of flammable gases and is designed for use with an approved junction box.

It employs a catalytic pellistor sensor device which is used as part of a bridge measuring circuit.

Sensepoint is certified for hazardous areas to EN60079 and is protected against water and dust ingress to IP67. The installation must be consistent with the certification approval.

The sensor is available in M20 or 3/4 NPT thread versions. The sensors can be fitted with accessories such as Weather Protection, Flow Housings (for use when calibrating the sensor and in sampling systems), and a Collecting Cone for the detection of gases which are lighter than air.

2. ASSOCIATED DOCUMENTATION

2106M0502 Sensepoint Technical Handbook
Refer to the relevant control system manual for connection information.



WARNINGS

- This apparatus is not suitable for use in oxygen enriched atmospheres (>21%v/v). Oxygen deficient atmospheres (<10%v/v) may suppress sensor output.
- Refer to local or national regulations relative to installation at the site.
- Operators should be fully aware of the action to be taken if the gas concentration exceeds an alarm level.
- Installation should consider not only the best placing for gas leakage related to potential leak points, gas characteristics and ventilation, but also where the potential of mechanical damage is minimized or avoided.
- Electrostatic risk - Do not rub or clean with solvents. Clean with a damp cloth. High velocity airflows and dusty environments can cause hazardous electrostatic charges.

CAUTIONS

- Atmospheres above 100% LEL may suppress the sensor reading.
 - Do not modify or alter the sensor construction as essential safety requirements may be invalidated.
 - Install using certified Ex e or Ex d junction box, connectors and glanding.
 - Dispose of in accordance with local disposal regulations. Materials used -Fortron® (PPS-Polyphenylene Sulphide)
 - This equipment is designed and constructed as to prevent ignition sources arising, even in the event of frequent disturbances or equipment operating faults.
- NOTE: The control card must have a suitably rated fuse.*



Find out more

www.sps.honeywell.com

Contact Honeywell Analytics:

Europe, Middle East, Africa
Life Safety Distribution GmbH
Tel: 00800 333 222 44 (Freephone no.)
Tel: +41 (0)44 943 4380 (Alternative no.)
Middle East Tel: +971 4 450 5800 (Fixed Gas Detection)
Middle East Tel: +971 4 450 5852 (Portable Gas Detection)
gasdetection@honeywell.com

Americas

Honeywell Analytics Inc.
Tel: +1 847 955 8200
Toll free: +1 800 538 0363
detectgas@honeywell.com

Asia Pacific

Honeywell Co., Ltd.
Tel: +82 (0) 2 6909 0300
India Tel: +91 124 4752700
China Tel: +86 10 5885 8788-3000
analytics.ap@honeywell.com

Technical Services

EMEA: HAexpert@honeywell.com
US: ha.us.service@honeywell.com
AP: ha.ap.service@honeywell.com

www.sps.honeywell.com

Please Note:

While every effort has been made to ensure accuracy in this publication, no responsibility can be accepted for errors or omissions. Data may change, as well as legislation, and you are strongly advised to obtain copies of the most recently issued regulations, standards, and guidelines. This publication is not intended to form the basis of a contract.

3. INSTALLATION

Installation and service must be performed by a qualified installation engineer with the power to the sensor disconnected.

The Sensepoint must be fitted into a suitably approved Ex e or Ex d junction box fitted with a suitably approved cable gland. This should be correctly installed before use.

The sensor should be installed in a location free from direct heat sources. For optimum protection against water ingress ensure that the sensor is installed facing downwards.

See the Sensepoint Gas Sensors Technical Handbook for installation in a duct or in forced air conditions.

Remove the sensor's protective disc before use by unscrewing the filter housing, removing the filter and then the disc. Discard the protective disc. Refit the filter into the filter housing and replace the filter housing on the sensor.

The field connections should be three-core multi-strand cable with a maximum conductor size of 2.5mm² (14AWG). A screened cable is necessary.

The sensor should be fitted into a threaded hole within the junction box and locked in place with a lock nut. Ensure that junction box thread is compatible with sensor thread.

Connect the field and Sensepoint wiring to the junction box connector block as shown in the following diagram. The unit requires 200mA current with a nominal 3V supply.

4. CALIBRATION

4.2 CROSS CALIBRATION

Calibration formula:

The PPM scale reading to be set is calculated using the formula:

$$S = \frac{C \times Y}{Z}$$

S = Scale reading to be set (ppm).

C = Concentration of calibration gas (ppm).

Y = Relative sensitivity to methane of calibration gas.

Z = Relative sensitivity to methane of gas to be detected.

Cross Calibration example:

- Target gas to be detected is xylene in the range 0-3000 ppm.
- Calibration gas available is ethane, concentration 2000 ppm.

Applying the calibration formula:

$$S = \frac{2000\text{ppm} \times 133}{173} = \frac{266000}{173} = 1538\text{ppm}$$

The control card scale (meter) should be set to 1500 ppm to give an accurate reading for xylene using 2000 ppm ethane as a calibration gas.

IMPORTANT

Where the user calibrates any sensor using a different gas, responsibility for identifying and recording calibration rests with the user. Refer to local regulations where appropriate.

Wiring connections are:-

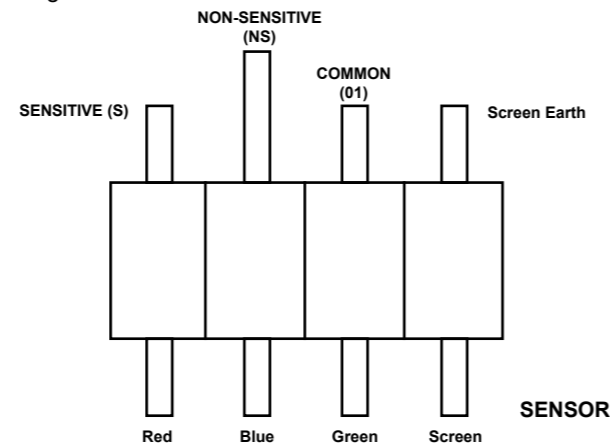

Following installation the sensor must be calibrated.

4. SENSOR CALIBRATION

Caution: Calibration procedures should only be carried out by qualified personnel.

Note: Sensors should be calibrated at concentrations representative of those to be measured. It is always recommended that the Sensepoint sensor is calibrated with the target gas it is to detect. If this is not possible, cross calibration should be performed.

Since combustible sensors require oxygen for correct operation, a mixture of gas in air should be used for calibration purposes.

4. CALIBRATION

Table 2: Recommended full scale deflection (fsd)

Gas or Vapour	fsd	Gas or Vapour	fsd
Acetone	5000 ppm	Hydrogen	5000 ppm
Ammonia	15000 ppm	MIBK	3000 ppm
Butane	5000 ppm	Octane	3000 ppm
Butanone (MEK)	5000 ppm	Propane	5000 ppm
Cyclohexane	3000 ppm	Tetrahydrofuran	5000 ppm
Diethyl ether	5000 ppm	Toluene	3000 ppm
Ethane	5000 ppm	Triethylamine	5000 ppm
Ethylene	3000 ppm	Xylene	3000 ppm
Heptane	3000 ppm	Methane	7000 ppm
Hexane	3000 ppm		

4.1 CALIBRATION PROCEDURE

The calibration adjustments are carried out at the control card and gassing is performed at the sensor.

- (1) Apply power and allow the sensor to warm up for 20 minutes.
- (2) First ensure there is no gas present on the sensor. If combustible gas is suspected to be in the vicinity of the Sensepoint sensor, fit a Flow Housing accessory and flow clean air over the sensor.
- (3) Set the zero reading on the control system.
- (4) Remove the filter housing or accessory and replace it with a Flow Housing accessory, if not already fitted.
- (5) Connect the Flow Housing input to a regulated cylinder, containing a known concentration of target gas at approximately the sensor alarm point (e.g. 50% FSD gas in air), using nylon or PTFE tubing.
- (6) Pass the gas through the Flow Housing at a flow rate of approximately 1 to 1.5 litres per minute. Allow the sensor two to three minutes to stabilise.
- (7) Adjust the control card to indicate the concentration of the target gas being applied

Caution: As some test gases may be hazardous, the Flow Housing outlet should exhaust to a safe area.

Note: It is useful to record the mV output of the sensor, via the control card, throughout the life of the sensor to ensure that there are no poisoning effects that will reduce the sensor performance. This would be indicated by a reduction in the mV output for the same gas concentration. It is recommended that the sensor is replaced when 60% loss has occurred.

For calibration using the Weather Protection in high flow applications refer to the technical handbook.

5. FAULT FINDING

5.1 FAULT FINDING

Caution: There are no user serviceable parts within the Sensepoint and attempted changes may invalidate the certification requirements.

Sensor reads non zero all the the time:

- gas could be present, ensure that there is no combustible gas in the atmosphere.

Sensor reads non zero when no gas is present:

- adjust the zero of the control system.

Sensor reads low when gas is applied:

- adjust the span of the control system.

Sensor reads high when gas is applied:

- adjust the span of the control system.

Sensor reads zero when gas is applied:

- check the wiring.
- check that the dust protection cap has been removed.
- check that the sinter is not obstructed.
- replace the sensor if poisoning is suspected.

4.2 CROSS CALIBRATION PROCEDURE

When the Sensepoint sensor is to be calibrated with a gas which is different from the gas/vapour to be detected, the following cross calibration procedure should be followed:

Table 1 lists gases according to the reaction they produce. (These are not applicable at %LEL levels). Other calibration information may be obtained from Honeywell Analytics or the Technical Handbook.

Table 1: Cross Sensitivities (measured at 20°C STP)

Applied gas or vapour	Relative sensitivity*	Applied gas or vapour	Relative sensitivity*
Acetone	120	Hydrogen	113
Ammonia	55	MIBK	181
Butane	164	Octane	197
Butanone (MEK)	140	Propane	153
Cyclohexane	193	Tetrahydrofuran	136
Diethyl ether	140	Toluene	181
Ethane	133	Triethylamine	142
Ethylene	181	Xylene	173
Heptane	200	Methane	100
Hexane	193		

* relative to Methane = 100

6. MAINTENANCE

6.1 CHANGING FILTERS

- Remove the black plastic retainer or accessory.
- Remove the old filter and replace it with a fresh filter.
- Replace the black plastic retainer or accessory

