

Installation Instructions for the AMR 2-Pin Speed Sensor Integrated Circuit: VM721V1

32336293

Issue B

GENERAL INFORMATION

Honeywell's Anisotropic Magnetostrictive (AMR) 2-Pin Speed Sensor Integrated Circuit (IC) is designed to detect the speed of a ring magnet encoder target using a unique* bridge design. The frequency of the digital supply current is proportional to the rotational speed of the target, and works over a wide range of speeds, temperatures and air gaps.

*Patent Pending

SOLDERING AND ASSEMBLY

CAUTION

IMPROPER SOLDERING

- Ensure leads are adequately supported during any forming/shearing operation so that they are not stressed inside the plastic case.
- Limit exposure to high temperatures.

Failure to comply with these instructions may result in product damage

Wave solder at 250°C to 260°C [482°F to 500°F] for a maximum of three seconds. Burrs are allowed only if full lead length will pass through a 0,68 mm [0.027 in] dia. hole.

CLEANING

CAUTION

IMPROPER CLEANING

Do not use pressure wash. High-pressure stream could force contaminants into the package.

Failure to comply with these instructions may result in product damage.

Use agitated rinse to clean the sensor.

CAUTION
ELECTROSTATIC DISCHARGE DAMAGE
Ensure proper ESD precautions are followed when handling this product.
Failure to comply with these instructions may result in product damage.



CAUTION
ELECTROSTATIC SENSITIVE DEVICES
DO NOT OPEN OR HANDLE EXCEPT AT A STATIC FREE WORKSTATION
ESD SENSITIVITY: CLASS 3

Table 1. Operating Characteristics (Over entire supply voltage range at $-40^{\circ}\text{C} \leq T_A \leq 150^{\circ}\text{C}$, unless otherwise specified)

Characteristic	Symbol	Condition	Min.	Typ.	Max.	Unit
Supply voltage	V_s	-40°C to 110°C 150°C	4.0 4.0	— —	24 9.0	V
Supply current: high	I_{sh}	digital high state	12	14	16	mA
low	I_{sl}	digital low state	5.9	6.95	8.0	
Duty cycle	—	—	40	50	60	%
Output switching time: rise time	t_r	metering resistor, no bypass capacitor	—	—	8	μs
fall time	t_f	metering resistor, no bypass capacitor	—	—	8	
Switching frequency	f	—	—	—	35	kHz

Table 2. Output Configuration

Characteristic	Condition	Configuration
Number of pulses per pole	—	1

Table 3. Application Requirements (At 4.0 V ≤ V_S ≤ 24V, -40°C ≤ T_A ≤ 150°C)

Characteristic	Symbol	Condition	Min.	Typ.	Max.	Unit
Magnetic flux	B	D _{max} , max. air gap, max. temp.	±30	—	—	Gauss
Magnetic flux with valid output increased jitter	B	D _{max} , max. air gap, max. temp.	±10	—	—	Gauss
Metering resistor	R	—	10	100 to 300	—	Ohm

Table 4. Absolute Maximum Ratings

Characteristic	Symbol	Condition	Min.	Typ.	Max.	Unit
Operating temperature	T _a	—	-40 [-40]	—	150 [302]	°C [°F]
Junction temperature	T _J	—	-40 [-40]	—	165 [329]	°C [°F]
Storage temperature	T _S	—	-40 [-40]	—	150 [302]	°C [°F]
Thermal resistance	R _{θJA}	—	—	—	—	°C/W
Supply voltage	V _S	—	-26.5	—	26.5	V
Soldering temperature	—	3 s max.	—	—	260 [500]	°C [°F]
ESD (HBM)	V _{ESD}	JEDEC JS-002-2014	—	—	±6	kV

NOTICE

Absolute maximum ratings are the extreme limits the device will momentarily withstand without damage to the device. Electrical and mechanical characteristics are not guaranteed if the rated voltage and/or currents are exceeded, nor will the device necessarily operate at absolute maximum ratings.

NOTICE

Large, stray magnetic fields in the vicinity of the sensor may adversely affect sensor performance.

Figure 1. Maximum Supply Voltage Rating

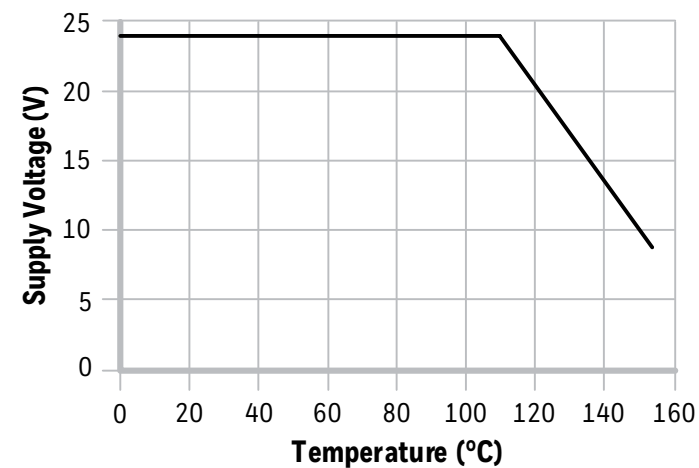

Figure 2. Block Diagram

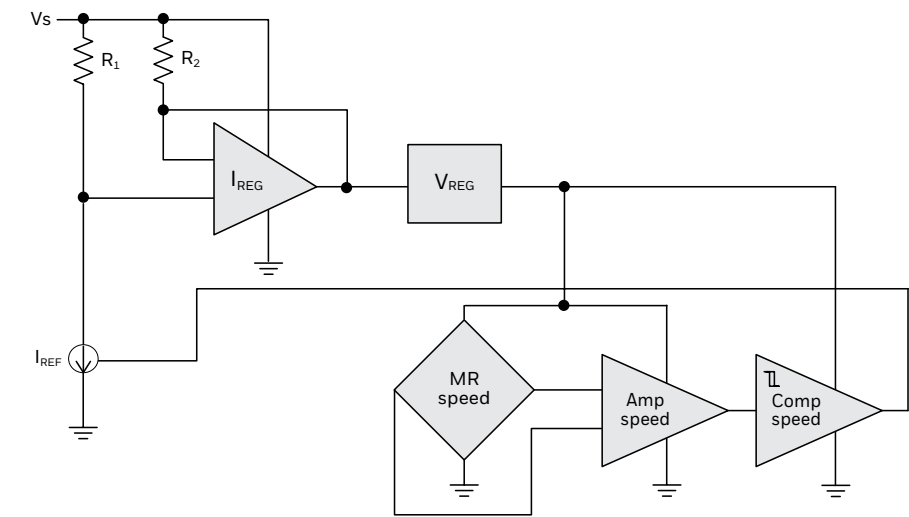

Figure 3. Basic Application Circuit

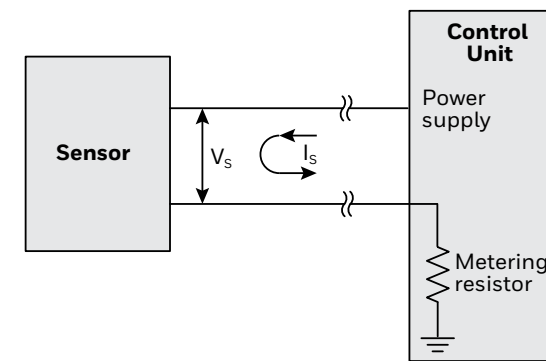

Figure 4. Rise and Fall Time Definition

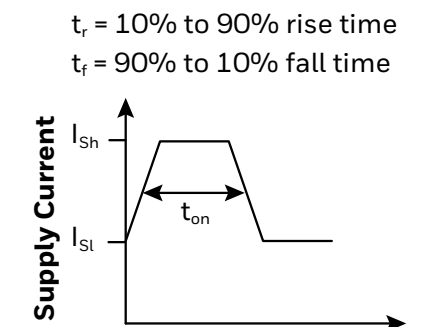
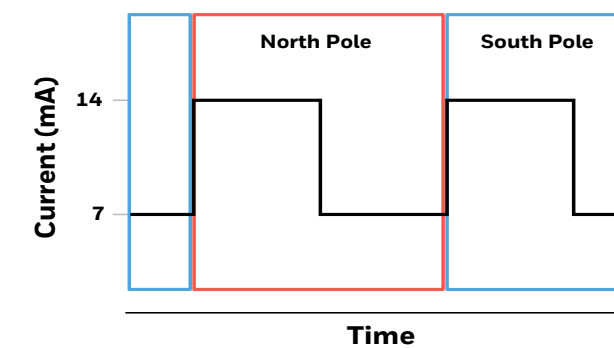

Figure 5. Transfer Characteristics



VM721V1

AMR 2-Pin Speed Sensor Integrated Circuit

Issue B

32336293

Figure 6. Sensor IC Mounting Orientation

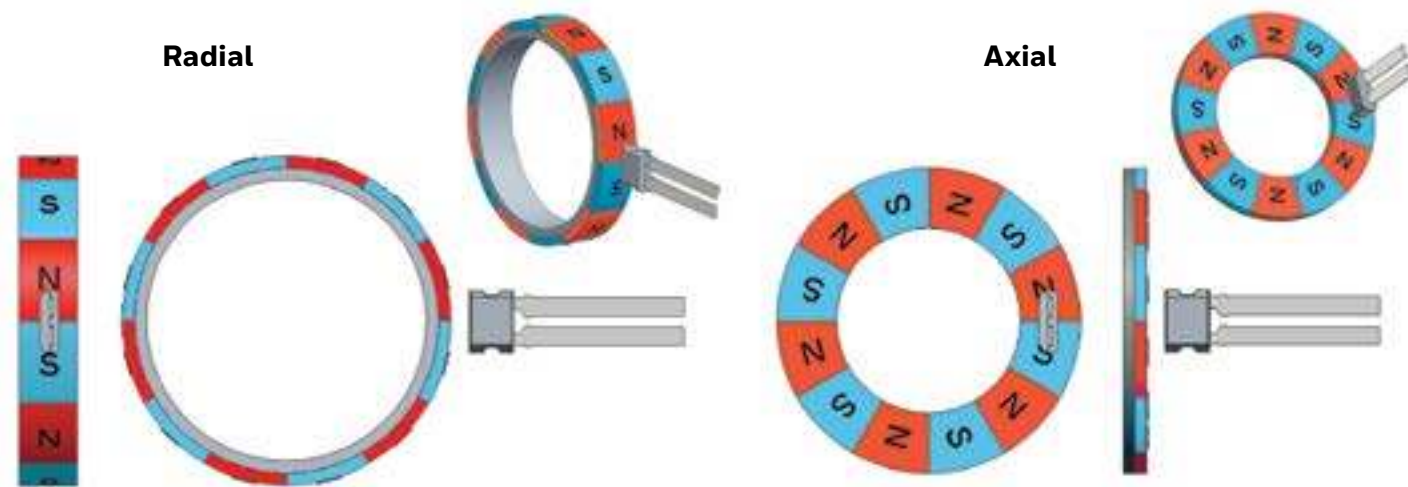
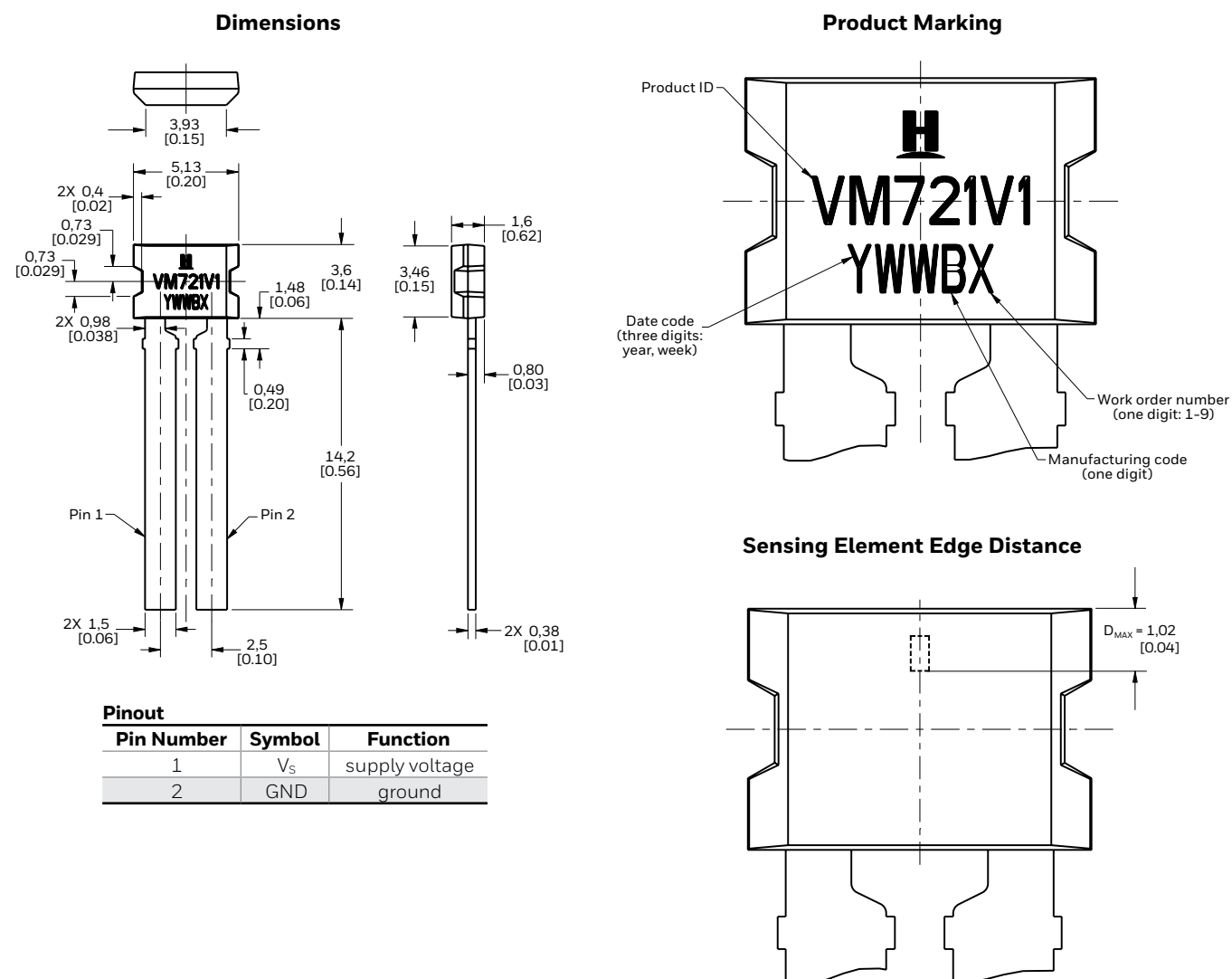

Figure 7. Dimensions and Product Marking (For reference only mm/[in])



⚠ WARNING RISK TO LIFE OR PROPERTY

Never use this product for an application involving serious risk to life or property without ensuring that the system as a whole has been designed to address the risks, and that this product is properly rated and installed for the intended use within the overall system.

Failure to comply with these instructions could result in death or serious injury.

Warranty/Remedy

Honeywell warrants goods of its manufacture as being free of defective materials and faulty workmanship during the applicable warranty period. Honeywell's standard product warranty applies unless agreed to otherwise by Honeywell in writing; please refer to your order acknowledgement or consult your local sales office for specific warranty details. If warranted goods are returned to Honeywell during the period of coverage, Honeywell will repair or replace, at its option, without charge those items that Honeywell, in its sole discretion, finds defective.

The foregoing is buyer's sole remedy and is in lieu of all other warranties, expressed or implied, including those of merchantability and fitness for a particular purpose. In no event shall Honeywell be liable for consequential, special, or indirect damages.

While Honeywell may provide application assistance personally, through our literature and the Honeywell web site, it is buyer's sole responsibility to determine the suitability of the product in the application.

Specifications may change without notice. The information we supply is believed to be accurate and reliable as of this writing. However, Honeywell assumes no responsibility for its use.

For more information

Honeywell Advanced Sensing Technologies services its customers through a worldwide network of sales offices and distributors.

For application assistance, current specifications, pricing or the nearest Authorized Distributor, visit sps.honeywell.com/ast or call:

Asia Pacific +65 6355-2828
Europe +44 (0) 1698 481481
USA/Canada +1-800-537-6945

Honeywell Advanced Sensing Technologies

830 East Arapaho Road
Richardson, TX 75081
sps.honeywell.com/ast

32336293-B-EN | B | 05/21
© 2021 Honeywell International Inc.

Honeywell