



HP ENVY 17m Laptop PC
HP ENVY 17 Laptop PC

Maintenance and Service Guide
IMPORTANT! This document is intended for HP
authorized service providers only.

© Copyright 2017 HP Development Company, L.P.

Bluetooth is a trademark owned by its proprietor and used by HP Inc. under license. NVIDIA is a trademark and/or registered trademark of NVIDIA Corporation in the U.S. and other countries. . Bluetooth is a trademark owned by its proprietor and used by HP Inc. under license. Intel and Core are trademarks of Intel Corporation in the U.S. and other countries. Windows is either a registered trademark or trademark of Microsoft Corporation in the United States and/or other countries.

The information contained herein is subject to change without notice. The only warranties for HP products and services are set forth in the express warranty statements accompanying such products and services. Nothing herein should be construed as constituting an additional warranty. HP shall not be liable for technical or editorial errors or omissions contained herein.

Second Edition: August 2017

First Edition: May 2017

Document Part Number: 927450-002

Product notice

This user guide describes features that are common to most models. Some features may not be available on your computer.

Not all features are available in all editions of Windows. This computer may require upgraded and/or separately purchased hardware, drivers and/or software to take full advantage of Windows functionality. Go to <http://www.microsoft.com> for details.

In accordance with Microsoft's support policy, HP does not support the Windows 8 or Windows 7 operating system on this product or provide any Windows 8 or Windows 7 drivers on <http://support.hp.com>.

Software terms

By installing, copying, downloading, or otherwise using any software product preinstalled on this computer, you agree to be bound by the terms of the HP End User License Agreement (EULA). If you do not accept these license terms, your sole remedy is to return the entire unused product (hardware and software) within 14 days for a full refund subject to the refund policy of your seller.

For any further information or to request a full refund of the price of the computer, please contact your seller.

Safety warning notice

 **WARNING!** To reduce the possibility of heat-related injuries or of overheating the device, do not place the device directly on your lap or obstruct the device air vents. Use the device only on a hard, flat surface. Do not allow another hard surface, such as an adjoining optional printer, or a soft surface, such as pillows or rugs or clothing, to block airflow. Also, do not allow the AC adapter to contact the skin or a soft surface, such as pillows or rugs or clothing, during operation. The device and the AC adapter comply with the user-accessible surface temperature limits defined by the International Standard for Safety of Information Technology Equipment (IEC 60950-1).

Table of contents

1 Product description	1
2 External component identification	5
Right side	5
Left side	5
Display	8
Keyboard area	9
TouchPad	9
Lights	9
Button and speakers	10
Special keys	12
Action keys	12
Bottom	14
Locating system information	15
3 Illustrated parts catalog	16
Computer major components	16
Miscellaneous parts	18
4 Removal and replacement procedures preliminary requirements	20
Tools required	20
Service considerations	20
Plastic parts	20
Cables and connectors	21
Drive handling	21
Grounding guidelines	22
Electrostatic discharge damage	22
Packaging and transporting guidelines	23
Workstation guidelines	23
Equipment guidelines	24
5 Removal and replacement procedures for authorized service provider parts	25
Component replacement procedures	25
Base enclosure	26
Battery	28
Display	29

Hard drive	31
Solid-state drive	33
Memory	35
WLAN module	37
Optical drive	39
Input/output brackets	41
Fan	43
TouchPad	45
USB board	48
System board	50
Heat sink	53
Speakers	55
Power connector	57
Top cover/keyboard	58
6 Using Setup Utility (BIOS)	59
Starting Setup Utility (BIOS)	59
Updating Setup Utility (BIOS)	59
Determining the BIOS version	59
Downloading a BIOS update	60
7 Using HP PC Hardware Diagnostics (UEFI)	61
Downloading HP PC Hardware Diagnostics (UEFI) to a USB device	62
8 Backing up, restoring, and recovering	63
Creating recovery media and backups	63
Using HP Recovery media (select products only)	63
Using Windows tools	64
Using the HP Cloud Recovery Download Tool (select products only)	65
Restore and recovery	65
Recovering using HP Recovery Manager	65
What you need to know before you get started	65
Using the HP Recovery partition (select products only)	66
Using HP Recovery media to recover	67
Changing the computer boot order	67
Removing the HP Recovery partition (select products only)	67
9 Specifications	68
Computer specifications	68
Display Specifications (17.3)	68

Hard drive specifications	70
M.2 solid-state drive specifications	71
M.2 solid-state drive specifications	72
M.2 PCIe solid-state drive specifications	73
10 Power cord set requirements	74
Requirements for all countries	74
Requirements for specific countries and regions	75
11 Recycling	77
Index	78

1 Product description

Category	Description
Product Name	HP ENVY 17m Laptop PC (model numbers 17m-ae001 through 17m-ae199) HP ENVY 17 Laptop PC (model numbers 17-ae001 through 17-ae199)
Processors	For use on computer models with model numbers 17m-ae001 through 17m-ae099 and models 17-ae001 through 17-ae099 <ul style="list-style-type: none">Intel® Core™ i7-7500U (2.5 GHz, turbo up to 3.1 GHz), 2133 MHz/ 3 MB L3 cache, Dual 15WIntel Core i5-7200U (2.5GHz, turbo up to 3.1 GHz, HDCP 2.2), 2133MHz/ 3MB L3, Dual 15W For use on computer models with model numbers 17m-ae100 through 17m-ae199 and models 17-ae100 through 17-ae199 <ul style="list-style-type: none">Intel Core i7-8550U (1.8 GHz, turbo up to 4.0 GHz), 2400 MHz/ 8 MB L3, Quad 15WIntel Core i5-8250U (1.6 GHz, turbo up to 3.4 GHz), 2400 MHz/ 6MB L3, Quad 15W
Chipset	Integrated SoC
Graphics	For use on all computer models with internal graphics: Intel® HD Graphics 620 Hybrid graphics: For use on computer models with model numbers 17m-ae100 through 17m-ae199 and models 17-ae100 through 17-ae199 NVIDIA N175-G1 (GeForce MX150) with up to 2048 MB of dedicated video memory (256 Mx32, GDDR5, x 2 PCs, 1 GHz@1.5V) NVIDIA N175-G1 (GeForce MX150) with up to 4096 MB of dedicated video memory (256 Mx32, GDDR5, x 4 PCs, 1 GHz@1.5V) Support for HD Decode, DX12, and HDMI Support for Optimus (discrete only) Support for GPU Performance Scaling (discrete only) For use on computer models with model numbers 17m-ae001 through 17m-ae099 and models 17-ae001 through 17-ae099 NVIDIA N165-GTR-S (GeForce 940MX) with up to 2048MB of dedicated video memory (256Mx16, DDR3, x 4 PCs, 1GHz@1.5V) NVIDIA N165-GTR-S (GeForce 940MX) with up to 4096MB of dedicated video memory (256Mx16, DDR3, x 8 PCs, 1GHz@1.5V) Support for HD Decode, DX12, and HDMI Support for Optimus (discrete only) Support for GPU Performance Scaling (discrete only)
Panels	16:9 Ultra Wide Aspect Ratio 17.3" FHD WLED AntiGlare (1920x1080) flat-flat (4.2mm) UWVA, eDP1.2 (DBCG) 17.3" FHD WLED AntiGlare (1920x1080) flat-flat (4.2mm) UWVA, eDP1.2 (DBTS) 17.3" UHD WLED AntiGlare (3840x2160) flat-flat (4.2mm) UWVA, eDP1.3+PSR (DBCG)

Category	Description
	<p>Touch solution with flush glass, multitouch enabled</p> <p>Support Active Stylus</p>
Memory	<p>Two SODIMM slots - Non-accessible/non-upgradeable</p> <p>DDR4-2400 Dual Channel Support (DDR4-2400 downgrade to DDR4-2133)</p> <p>Supports up to 16 GB max system memory</p> <p>8192 MB (4096 MB x 2)</p> <p>12288 MB (8192 MB +4096 MB)</p> <p>16384 MB (8192 MB x 2)</p>
Storage	<p>Support for all 7.2mm/9.5mm, SATA 2.5" hard drives</p> <p>Support for next generation form factor (NGFF) M.2 solid-state drive, with SATA/Peripheral Component Interconnect Express (SATA/PCI)e co-layout port</p> <p>Support for solid-state drive + hard drive</p> <p>Support for M.2 solid-state drive (support storage function, assuming solid-state drive >= 128G, Port1)</p> <p>Accelerometer / hard drive protection support</p> <p>Single hard drive configurations:</p> <ul style="list-style-type: none"> • 1TB (7200) 9.5mm/7mm <p>Dual storage configurations:</p> <ul style="list-style-type: none"> • 128 GB SATA TLC solid-state drive (Value) + 1 TB (7200) hard drive • 256 GB PCIe NVMe TLC solid-state drive + 1 TB (7200) hard drive • 256 GB PCIe NVMe Value solid-state drive + 1TB (7200) hard drive <p>PCIe NVMe TLC M.2 solid-state drive</p> <ul style="list-style-type: none"> • 360 GB • 512 GB • 1 TB <p>PCIe NVMe Value M.2 solid-state drive</p> <ul style="list-style-type: none"> • 512 GB
Optical drive	<p>9.0mm tray load - SATA - Fixed (not modular)</p> <p>DVD+/-RW Double-Layer Dual</p> <p>Supports Zero-Power ODD</p> <p>Supports M-disc</p>
Camera and microphone	<p>HP Wide Vision FHD IR Camera - indicator LED & 2x IR LEDs, USB2.0, FHD Hybrid B</p> <p>1080p by 30 frames per second</p> <p>Supports Windows® Hello</p> <p>Dual array Digital Microphones w/ appropriate software - beam forming, echo cancellation, noise suppression</p>
Audio	<p>BANG & OLUFSEN</p> <p>BANG & OLUFSEN Audio Control</p> <p>Supports HP Audio Boost 2.0 (with discrete amplifier)</p>



Category	Description
	Dual Speakers
Ethernet	Integrated 10/100/1000 NIC
Sensor	Accelerometer
Wireless networking	<p>Integrated Wireless options with dual antennas (M.2/PCIe):</p> <p>Intel Dual Band Wireless-AC 7265 802.11 AC 2x2 WiFi + BT 4.2 Combo Adapter (non-vPro)</p> <p>Realtek RTL8822BE 802.11 ac 2x2 WiFi + BT 4.2 Combo Adapter (MU-MIMO supported)</p> <p>Compatible with Miracast-certified devices</p>
External card expansion	<p>HP Multi-Format Digital Media Card Reader</p> <p>Supports SD/SDHC/SDXC</p> <p>Push-Push Insertion/Removal</p>
Internal card expansion	<p>One M.2 slot for SSD</p> <p>One M.2 slot for WLAN</p>
Input/Output	<p>Hot Plug / Unplug and auto detect for correct output to wide-aspect vs. standard aspect video</p> <p>HDMI v2.0a (HDR) + HDCP2.2 supporting: up to 4096x2160 @ 60Hz</p> <p>Headphone/Line-out and Mic-in (combo)</p> <p>USB type A 3.1 ports on Unit:</p> <p>3 (2 on the left side; 1 on the right side)</p> <p>Support HP Sleep & Charge (1 on the right side)</p> <p>USB type C 3.1 port Gen 1 on Unit (left side):</p> <p>1 (1 on the left side)</p> <p>Support data transfer</p> <p>Support Display Port (DP1.2+ HDCP 2.2 supporting up to 4096x2160 @ 60Hz)</p> <p>Support HP Sleep & Charge (without BC 1.2)</p> <p>RJ-45 / Ethernet</p> <p>AC Smart Pin adapter plug</p>
Keyboard	<p>Keyboard:</p> <p>Full Size Backlit island-style Keyboard with numeric keypad, Pike Silver (15.6"/17.3")</p> <p>Touchpad Requirements:</p> <p>ClickPad with image sensor</p> <p>Multitouch gestures enabled</p> <p>Support Modern Trackpad Gestures</p> <p>Taps enabled as default</p>
Mechanical requirements	<p>Chassis buttons</p> <p>Power</p> <p>LED indicators</p>
Power requirements	Battery:

Category	Description
	3 cell Prismatic battery - 55.8Whr (3S1P, 4835mAh) Support battery fast charge AC adapter Barrel Type: 65W with duckhead and/or duckhead power cords 90W Power Cord/Duckhead/Duckhead Power Cord: Duckhead (C5) 1M duckhead power cord w/ tag label (C5) 1M premium power cord w/ tag label (C5)
Security	TPM 2.0 Kensington Security Lock
Operating system	Preinstalled: Windows 10 Windows 10 Pro For Developed Market (ML): Windows 10 Home ML Windows 10 Home Plus ML For Emerging Market (EM/SL): Windows 10 Home EM/SL Windows 10 Home PlusEM/SL For China Market: CPPP Windows 10 Home High End China Language Edition CPPP Windows 10 Home China Language Edition For APJ SEAP Market (EM/SL): SEAP Windows 10 Home EM/SL SEAP Windows 10 Home Plus
Serviceability	End user replaceable parts: AC adapter Raw Panel Replacement

2 External component identification

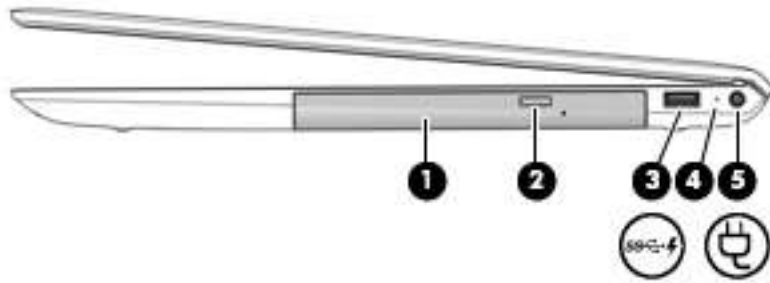





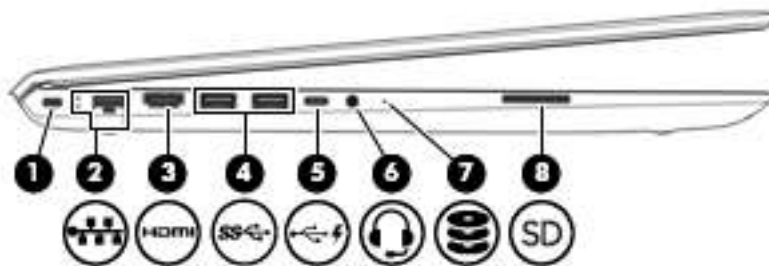

Right side



Component	Description
(1) Optical drive	Depending on your computer model, reads an optical disc or reads and writes to an optical disc.
(2) Optical drive eject button	Releases the optical drive disc tray.
(3)  USB 3.x SuperSpeed port with HP Sleep and Charge	Connects a USB device, provides high-speed data transfer, and even when the computer is off, charges most products such as a cell phone, camera, activity tracker, or smartwatch.
(4) AC adapter and battery light	<ul style="list-style-type: none"> White: The AC adapter is connected and the battery is fully charged. Blinking white: The AC adapter is disconnected and the battery has reached a low battery level. Amber: The AC adapter is connected and the battery is charging. Off: The battery is not charging.
(5)  Power connector	Connects an AC adapter.

Left side



Component	Description
(1)  Security cable slot	Attaches an optional security cable to the computer. NOTE: The security cable is designed to act as a deterrent, but it may not prevent the computer from being mishandled or stolen.
(2)  RJ-45 (network) jack/status lights	Connects a network cable. <ul style="list-style-type: none"> • White: The network is connected. • Amber: Activity is occurring on the network.
(3)  HDMI port	Connects an optional video or audio device, such as a high-definition television, any compatible digital or audio component, or a high-speed High-Definition Multimedia Interface (HDMI) device.
(4)  USB 3.x SuperSpeed ports (2)	Connect a USB device, such as a cell phone, camera, activity tracker, or smartwatch, and provide high-speed data transfer.
(5)  USB Type-C port with HP Sleep and Charge	When the computer is on, connects and charges a USB device that has a Type-C connector, such as a cell phone, camera, activity tracker, or smartwatch, and provides high-speed data transfer. – or – Connects to various USB, video, HDMI, and LAN devices. NOTE: Cables and/or adapters (purchased separately) may be required. – or – Connects a DisplayPort device that has a USB Type-C connector, providing display output.
(6)  Audio-out (headphone)/Audio-in (microphone) combo jack	Connects optional powered stereo speakers, headphones, earbuds, a headset, or a television audio cable. Also connects an optional headset microphone. This jack does not support optional standalone microphones. WARNING! To reduce the risk of personal injury, adjust the volume before putting on headphones, earbuds, or a headset. For additional safety information, refer to the <i>Regulatory, Safety, and Environmental Notices</i> . To access this guide: ▲ Select the Start button, select HP Help and Support , and then select HP Documentation . NOTE: When a device is connected to the jack, the computer speakers are disabled.
(7)  Drive light	<ul style="list-style-type: none"> • Blinking white: The hard drive is being accessed. • Amber: HP 3D DriveGuard has temporarily parked the hard drive.
(8)  SD Memory card reader	Reads optional memory cards that enable you to store, manage, share, or access information. To insert a card: 1. Hold the card label-side up, with connectors facing the computer.

Component	Description
	<p>2. Insert the card into the memory card reader, and then press in on the card until it is firmly seated.</p>
	<p>To remove a card:</p>
	<p>▲ Press in on the card, and then remove it from the memory card reader.</p>

Display



Component	Description
(1) WLAN antennas* (2)	Send and receive wireless signals to communicate with wireless local area networks (WLANs).
(2) Camera light(s)	On: One or more cameras are in use.
(3) Internal microphones (2)	Record sound.
(4) Camera(s)	Allow you to video chat, record video, and record still images. Some cameras also allow a facial recognition logon to Windows, instead of a password logon. NOTE: Camera functions vary depending on the camera hardware and software installed on your product.

*The antennas are not visible from the outside of the computer, and antenna location varies. For optimal transmission, keep the areas immediately around the antennas free from obstructions.

For wireless regulatory notices, see the section of the *Regulatory, Safety, and Environmental Notices* that applies to your country or region.

To access this guide:

- ▲ Select the **Start** button, select **HP Help and Support**, and then select **HP Documentation**.

Keyboard area

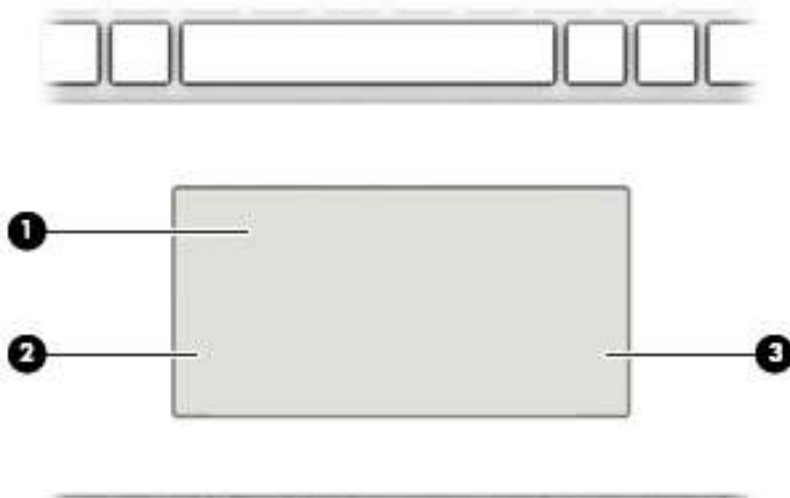

TouchPad

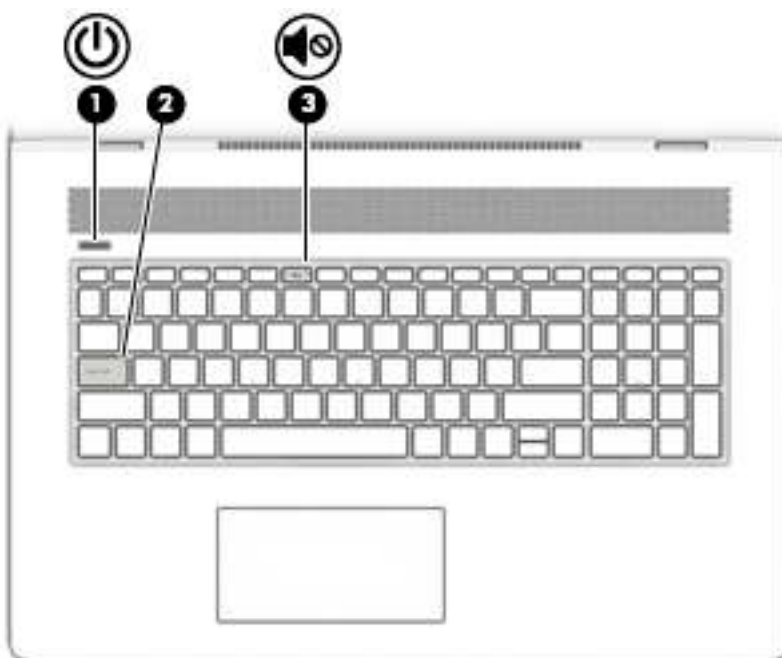

Component	Description
(1)	TouchPad zone Reads your finger gestures to move the pointer or activate items on the screen.
(2)	Left TouchPad button Functions like the left button on an external mouse.
(3)	Right TouchPad button Functions like the right button on an external mouse.

Lights



Component	Description
(1)  Power light	<ul style="list-style-type: none"> • On: The computer is on. • Blinking: The computer is in the Sleep state, a power-saving state. The computer shuts off power to the display and other unneeded components. • Off: The computer is off or in Hibernation. Hibernation is a power-saving state that uses the least amount of power.
(2) Caps lock light	On: Caps lock is on, which switches the key input to all capital letters.
(3)  Mute light	<ul style="list-style-type: none"> • On: Computer sound is off. • Off: Computer sound is on.

Button and speakers

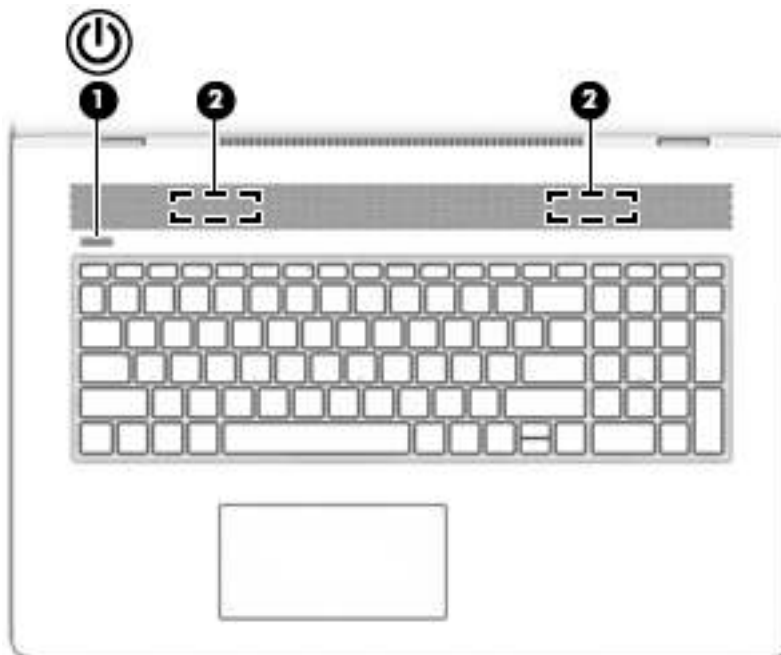

Component	Description
(1)  Power button	<ul style="list-style-type: none"> • When the computer is off, press the button to turn on the computer. • When the computer is on, press the button briefly to initiate Sleep. • When the computer is in the Sleep state, press the button briefly to exit Sleep. • When the computer is in Hibernation, press the button briefly to exit Hibernation. <p>CAUTION: Pressing and holding down the power button results in the loss of unsaved information.</p>

Component	Description
(2)	Speakers
<p>If the computer has stopped responding and shutdown procedures are ineffective, press and hold the power button down for at least 5 seconds to turn off the computer.</p> <p>To learn more about your power settings, see your power options.</p> <p>▲ Right-click the Start button, and then select Power Options.</p>	Produce sound.

Special keys

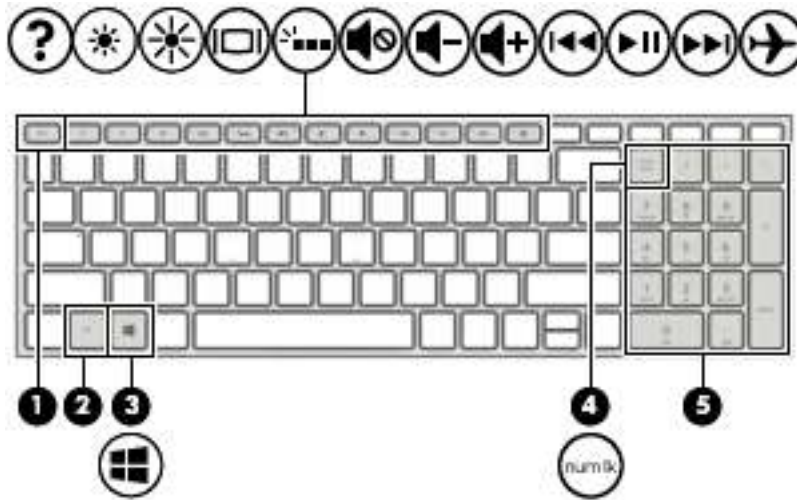













Component	Description
(1) esc key	Displays system information when pressed in combination with the fn key.
(2) fn key	Executes specific functions when pressed in combination with another key.
(3)  Windows key	Opens the Start menu. NOTE: Pressing the Windows key again will close the Start menu.
(4) num lock key	Alternates between the navigational and numeric functions on the integrated numeric keypad.
(5) Integrated numeric keypad	A separate keypad to the right of the alphabet keyboard. When num lock is pressed, the keypad can be used like an external numeric keypad. NOTE: If the keypad function is active when the computer is turned off, that function is reinstated when the computer is turned back on.

Action keys

An action key performs the function indicated by the icon on the key. To determine which keys are on your product, see [Special keys on page 12](#).

- ▲ To use an action key, press and hold the key.

Icon	Description
	Opens the "How to get help in Windows 10" webpage.
	Decreases the screen brightness incrementally as long as you hold down the key.

Icon	Description
	Increases the screen brightness incrementally as long as you hold down the key.
	Switches the screen image between display devices connected to the system. For example, if a monitor is connected to the computer, repeatedly pressing this key alternates the screen image from the computer display to the monitor display to a simultaneous display on both the computer and the monitor.
	Turns the keyboard backlight off or on. NOTE: To conserve battery power, turn off this feature.
	Mutes or restores speaker sound.
	Decreases speaker volume incrementally while you hold down the key.
	Increases speaker volume incrementally while you hold down the key.
	Plays the previous track of an audio CD or the previous section of a DVD or a Blu-ray Disc (BD).
	Starts, pauses, or resumes playback of an audio CD, a DVD, or a BD.
	Plays the next track of an audio CD or the next section of a DVD or a BD.
	Turns the airplane mode and wireless feature on or off. NOTE: The airplane mode key is also referred to as the wireless button. NOTE: A wireless network must be set up before a wireless connection is possible.

Bottom

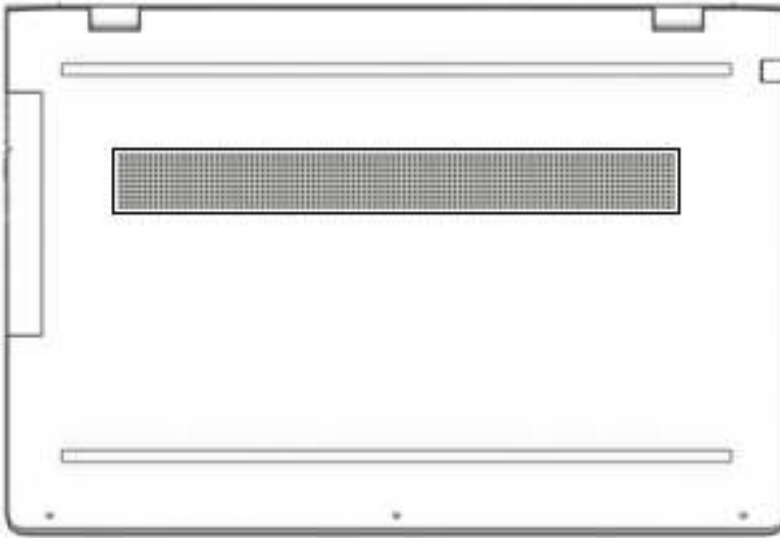

Description

Vent

Enables airflow to cool internal components.

NOTE: The computer fan starts up automatically to cool internal components and prevent overheating. It is normal for the internal fan to cycle on and off during routine operation.

Locating system information

Important system information is located on the bottom edge of the tablet or on the keyboard base. You may need the information when travelling internationally or when you contact support:

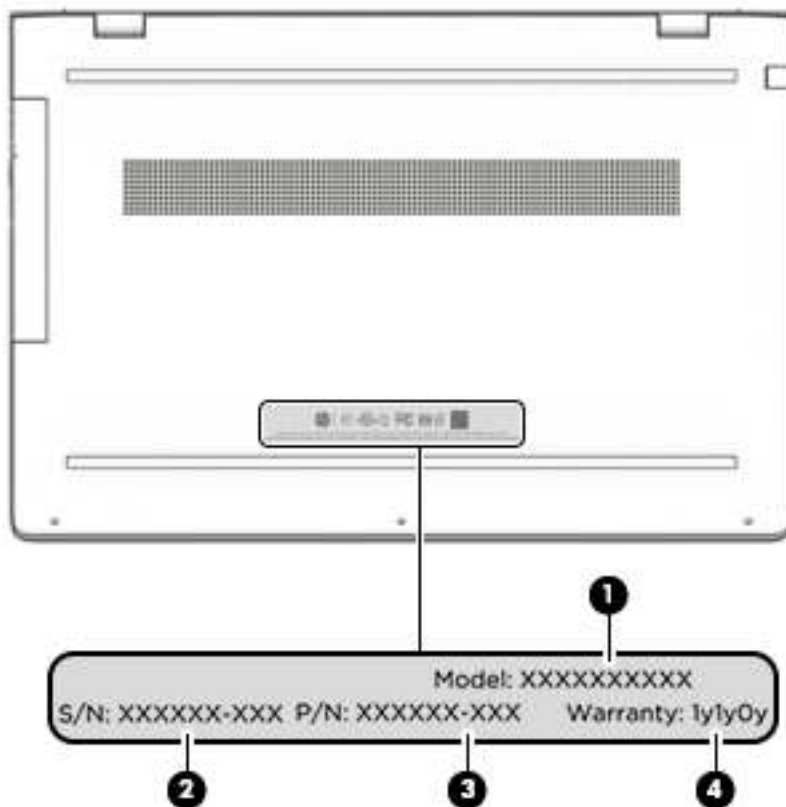

- (1):** Serial number
- (2):** Product number
- (3):** Model number
- (4):** Warranty period



Using Windows, briefly press the **fn+esc** key combination to display the System Information screen, which provides the product name and serial number of your computer, as well as information about the memory, processor, BIOS, and keyboard.

3 Illustrated parts catalog

Computer major components

-
-  **NOTE:** HP continually improves and changes product parts. For complete and current information on supported parts for your computer, go to <http://partsurfer.hp.com>, select your country or region, and then follow the on-screen instructions.
 -  **NOTE:** Details about your computer, including model, serial number, product key, and length of warranty, are on the service tag at the bottom of your computer. See [Locating system information on page 15](#) for details.
-

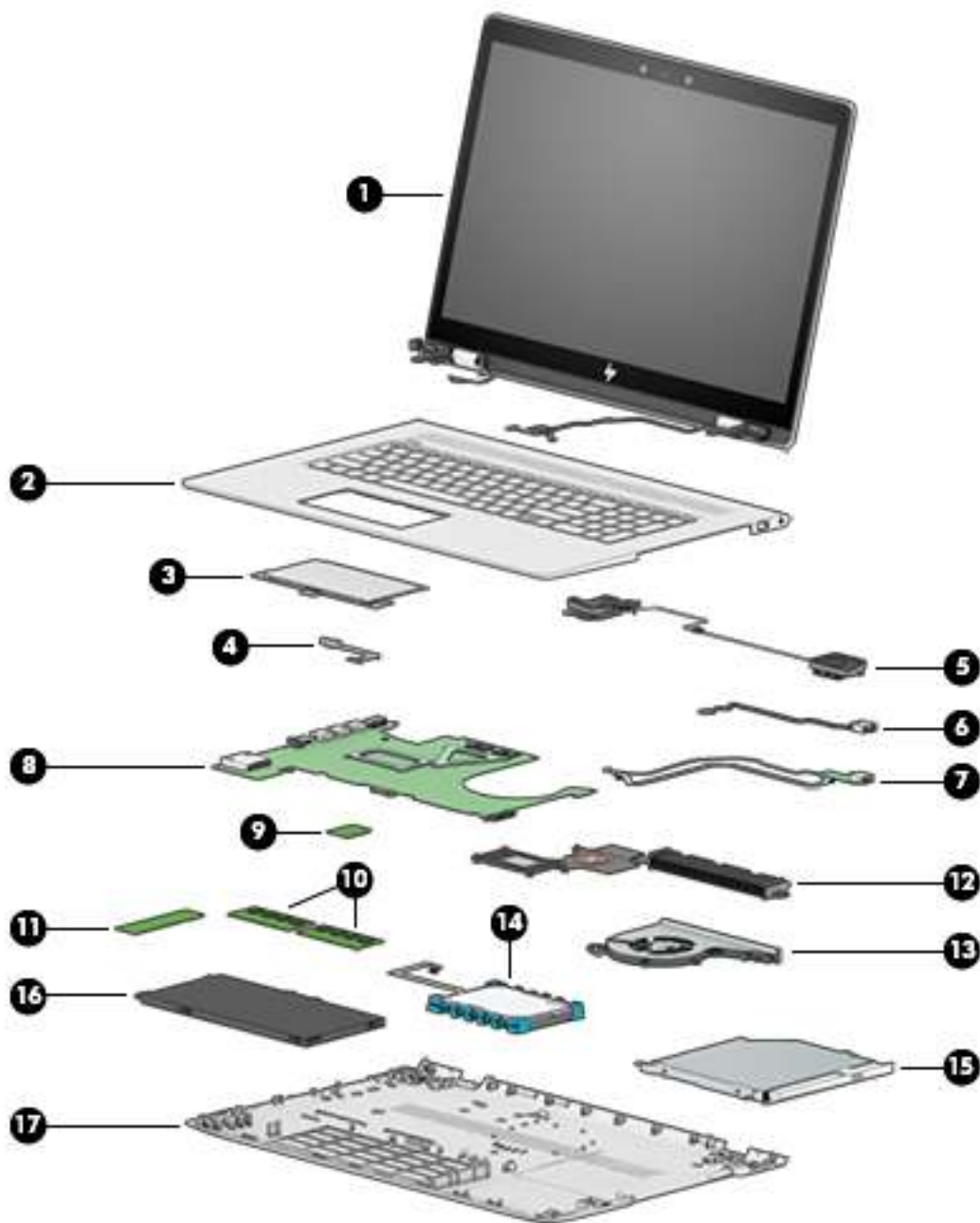

Item	Component	Spare part number
(1)	Display assembly (see Display on page 29)	
(2)	Top cover/keyboard (see Top cover/keyboard on page 58)	
(3)	TouchPad module	935941-001
(4)	TouchPad cable	925459-001
(5)	Speakers	925476-001
(6)	Power connector (includes cable)	810326-012
(7)	USB board	

Item	Component	Spare part number
	8L	925470-001
	10L	L02141-001
	Cable, USB FFC	928573-001
	Cable, USB	925458-001
(8)	System board (see System board on page 50)	
(9)	WLAN module	
	WLAN Assembly, 11AC+BT INT 7265NV M.2 D1 MOW	901229-855
	WLAN Assembly RT CARTIER AC 2X2	924813-855
(10)	Memory	
	SODIMM 4 GB 2400 MHz 1.2v DDR4	862397-855
	SODIMM 8 GB 2400 MHz 1.2v DDR4	862398-855
(11)	Solid-state drive (see Solid-state drive on page 33)	
(12)	Heat sink	925478-001
(13)	Fan	925461-001
(14)	Hard drive	766644-005
(15)	Optical drive	920417-005
(16)	Battery	916814-855
(17)	Base enclosure	925454-001

Miscellaneous parts

Component	Spare part number
AC adapter, 90W	710413-001
AC adapter, 65W	854117-850
Adapter, HP HDMI to VGA	701943-001
Dongle, USB-C to USB-A	833960-001
Pen	910942-001
Hook	933393-001
Power cord, AC line, 1.0 m	
For use in North America	213349-015
For use in Europe	213350-014
For use in the United Kingdom	213351-013
For use in Denmark	213353-013

Component	Spare part number
For use in Switzerland	213354-013
For use in South Africa	361240-007
For use in Israel	398063-008
For use in Israel	398063-008
Power cord, C5, 1.0 m	
For use in North America	920689-001
For use in Europe	920689-005
For use in the United Kingdom	920689-006
For use in Denmark	920689-007
For use in Israel	920689-008
For use in Switzerland	920689-009
For use in South America	920689-010
Rubber kit	935940-001
Screw kit	925475-001

4 Removal and replacement procedures preliminary requirements

Tools required

You will need the following tools to complete the removal and replacement procedures:

- Flat-bladed screwdriver
- Magnetic screwdriver
- Phillips P0 and P1 screwdrivers

Service considerations

The following sections include some of the considerations that you must keep in mind during disassembly and assembly procedures.



NOTE: As you remove each subassembly from the computer, place the subassembly (and all accompanying screws) away from the work area to prevent damage.

Plastic parts



CAUTION: Using excessive force during disassembly and reassembly can damage plastic parts. Use care when handling the plastic

Cables and connectors

⚠ CAUTION: When servicing the computer, be sure that cables are placed in their proper locations during the reassembly process. Improper cable placement can damage the computer.

Cables must be handled with extreme care to avoid damage. Apply only the tension required to unseat or seat the cables during removal and insertion. Handle cables by the connector whenever possible. In all cases, avoid bending, twisting, or tearing cables. Be sure that cables are routed in such a way that they cannot be caught or snagged by parts being removed or replaced. Handle flex cables with extreme care; these cables tear easily.

Drive handling

⚠ CAUTION: Drives are fragile components that must be handled with care. To prevent damage to the computer, damage to a drive, or loss of information, observe these precautions:

Before removing or inserting a hard drive, shut down the computer. If you are unsure whether the computer is off or in Hibernation, turn the computer on, and then shut it down through the operating system.

Before handling a drive, be sure that you are discharged of static electricity. While handling a drive, avoid touching the connector.

Before removing an optical drive, be sure that a disc is not in the drive and be sure that the optical drive tray is closed.

Handle drives on surfaces covered with at least one inch of shock-proof foam.

Avoid dropping drives from any height onto any surface.

After removing a hard drive or an optical drive, place it in a static-proof bag.

Avoid exposing an internal hard drive to products that have magnetic fields, such as monitors or speakers.

Avoid exposing a drive to temperature extremes or liquids.

If a drive must be mailed, place the drive in a bubble pack mailer or other suitable form of protective packaging and label the package "FRAGILE."

Grounding guidelines

Electrostatic discharge damage

Electronic components are sensitive to electrostatic discharge (ESD). Circuitry design and structure determine the degree of sensitivity. Networks built into many integrated circuits provide some protection, but in many cases, ESD contains enough power to alter device parameters or melt silicon junctions.

A discharge of static electricity from a finger or other conductor can destroy static-sensitive devices or microcircuitry. Even if the spark is neither felt nor heard, damage may have occurred.

An electronic device exposed to ESD may not be affected at all and can work perfectly throughout a normal cycle. Or the device may function normally for a while, then degrade in the internal layers, reducing its life expectancy.

⚠ CAUTION: To prevent damage to the computer when you are removing or installing internal components, observe these precautions:

Keep components in their electrostatic-safe containers until you are ready to install them.

Before touching an electronic component, discharge static electricity by using the guidelines described in this section.

Avoid touching pins, leads, and circuitry. Handle electronic components as little as possible.

If you remove a component, place it in an electrostatic-safe container.

The following table shows how humidity affects the electrostatic voltage levels generated by different activities.

⚠ CAUTION: A product can be degraded by as little as 700 V.

Typical electrostatic voltage levels			
Event	Relative humidity		
	10%	40%	55%
Walking across carpet	35,000 V	15,000 V	7,500 V
Walking across vinyl floor	12,000 V	5,000 V	3,000 V
Motions of bench worker	6,000 V	800 V	400 V
Removing DIPS from plastic tube	2,000 V	700 V	400 V
Removing DIPS from vinyl tray	11,500 V	4,000 V	2,000 V
Removing DIPS from plastic foam	14,500 V	5,000 V	3,500 V
Removing bubble pack from PCB	26,500 V	20,000 V	7,000 V
Packing PCBs in foam-lined box	21,000 V	11,000 V	5,000 V

Packaging and transporting guidelines

Follow these grounding guidelines when packaging and transporting equipment:

- To avoid hand contact, transport products in static-safe tubes, bags, or boxes.
- Protect ESD-sensitive parts and assemblies with conductive or approved containers or packaging.
- Keep ESD-sensitive parts in their containers until the parts arrive at static-free workstations.
- Place items on a grounded surface before removing items from their containers.
- Always be properly grounded when touching a component or assembly.
- Store reusable ESD-sensitive parts from assemblies in protective packaging or nonconductive foam.
- Use transporters and conveyors made of antistatic belts and roller bushings. Be sure that mechanized equipment used for moving materials is wired to ground and that proper materials are selected to avoid static charging. When grounding is not possible, use an ionizer to dissipate electric charges.

Workstation guidelines

Follow these grounding workstation guidelines:

- Cover the workstation with approved static-shielding material.
- Use a wrist strap connected to a properly grounded work surface and use properly grounded tools and equipment.
- Use conductive field service tools, such as cutters, screwdrivers, and vacuums.
- When fixtures must directly contact dissipative surfaces, use fixtures made only of static safe materials.
- Keep the work area free of nonconductive materials, such as ordinary plastic assembly aids and plastic foam.
- Handle ESD-sensitive components, parts, and assemblies by the case or PCM laminate. Handle these items only at static-free workstations.
- Avoid contact with pins, leads, or circuitry.
- Turn off power and input signals before inserting or removing connectors or test equipment.

Equipment guidelines

Grounding equipment must include either a wrist strap or a foot strap at a grounded workstation.

- When seated, wear a wrist strap connected to a grounded system. Wrist straps are flexible straps with a minimum of one megohm $\pm 10\%$ resistance in the ground cords. To provide proper ground, wear a strap snugly against the skin at all times. On grounded mats with banana-plug connectors, use alligator clips to connect a wrist strap.
- When standing, use foot straps and a grounded floor mat. Foot straps (heel, toe, or boot straps) can be used at standing workstations and are compatible with most types of shoes or boots. On conductive floors or dissipative floor mats, use foot straps on both feet with a minimum of one megohm resistance between the operator and ground. To be effective, the conductive equipment must be worn in contact with the skin.

The following grounding equipment is recommended to prevent electrostatic damage:

- Antistatic tape
- Antistatic smocks, aprons, and sleeve protectors
- Conductive bins and other assembly or soldering aids
- Nonconductive foam
- Conductive tabletop workstations with ground cords of one megohm resistance
- Static-dissipative tables or floor mats with hard ties to the ground
- Field service kits
- Static awareness labels
- Material-handling packages
- Nonconductive plastic bags, tubes, or boxes
- Metal tote boxes
- Electrostatic voltage levels and protective materials

The following table lists the shielding protection provided by antistatic bags and floor mats.

Material	Use	Voltage protection level
Antistatic plastics	Bags	1,500 V
Carbon-loaded plastic	Floor mats	7,500 V
Metallized laminate	Floor mats	5,000 V

5 Removal and replacement procedures for authorized service provider parts

 **CAUTION:** Components described in this chapter should be accessed only by an authorized service provider. Accessing these parts can damage the computer or void the warranty.

CAUTION: This computer does not have user-replaceable parts. Only HP authorized service providers should perform the removal and replacement procedures described here. Accessing the internal part could damage the computer or void the warranty.

Component replacement procedures

 **NOTE:** Details about your computer, including model, serial number, product key, and length of warranty, are on the service tag at the bottom of your computer. See [Locating system information on page 15](#) for details.

 **NOTE:** HP continually improves and changes product parts. For complete and current information on supported parts for your computer, go to <http://partsurfer.hp.com>, select your country or region, and then follow the on-screen instructions.

There are as many as 62 screws that must be removed, replaced, and/or loosened when servicing the parts described in this chapter. Make special note of each screw size and location during removal and replacement.

Base enclosure

Description	Spare part number
Base enclosure	925454-001

 **IMPORTANT:** Make special note of each screw and screw lock size and location during removal and replacement

Before removing the base enclosure, follow these steps:

1. Shut down the computer.
2. Disconnect all external devices connected to the computer.
3. Disconnect the power from the computer by first unplugging the power cord from the AC outlet and then unplugging the AC adapter from the computer.

Remove the base enclosure:

1. Insert a paper clip **(1)** to release the optical drive, slide the optical drive out **(2)**, and then remove the screw **(3)**.

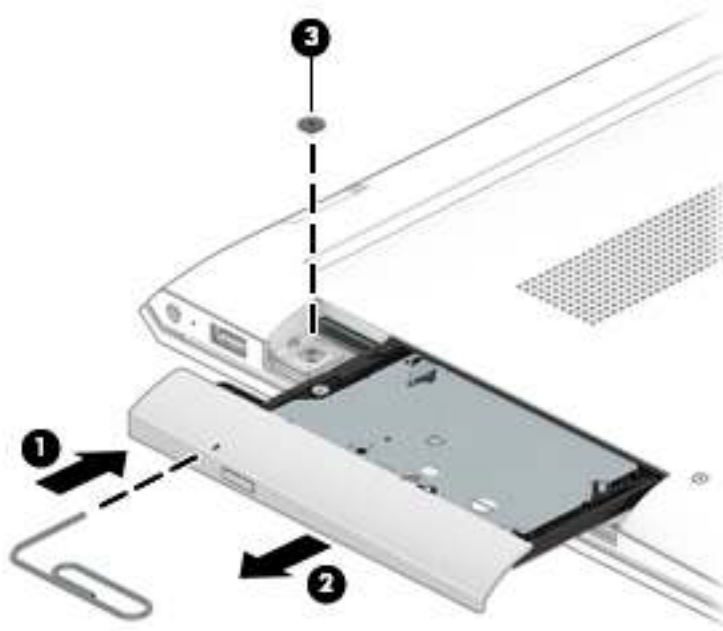

2. Remove the rubber strip **(1)**.
3. Remove 3 screws under the rubber strip **(2)**.
4. Remove 4 screws **(3)**.

5. Lift the base enclosure (4), and then remove it (5).

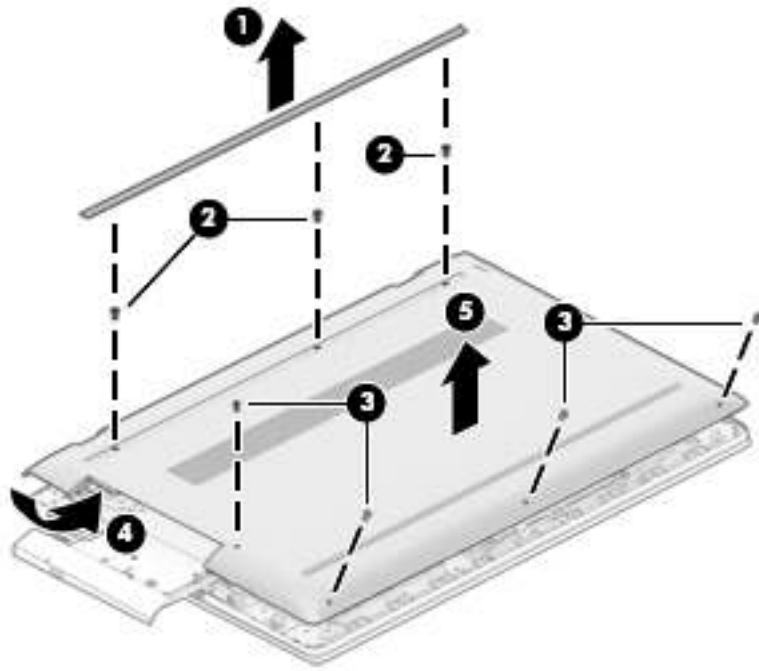

Reverse this procedure to install the base enclosure.

Battery

Description	Spare part number
Battery, 3-cell 55Whr 4.8Ah LI LK03055XL-PR	916814-855

 **IMPORTANT:** Make special note of each screw and screw lock size and location during removal and replacement

Before removing the battery, follow these steps:

1. Shut down the computer.
2. Disconnect all external devices connected to the computer.
3. Disconnect the power from the computer by first unplugging the power cord from the AC outlet and then unplugging the AC adapter from the computer.
4. Remove the base enclosure (see [Base enclosure on page 26](#))

Remove the battery:

- ▲ Remove 7 screws **(1)**, and then lift the battery **(2)** to remove it.

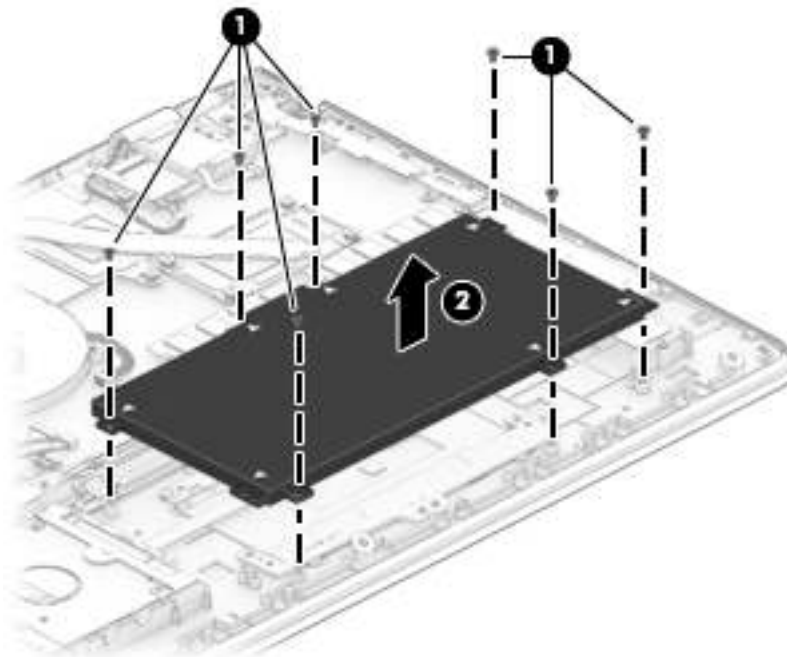

Reverse this procedure to install the battery.

Display

Description	Spare part number
Hinge-up Kit	
HU LCD 17.3 FHD AG UWVA (Touch screen)	925547-001
HU LCD 17.3 FHD AG UWVA	935938-001
LCD 17.3 UHD AG UWVA with bezel	935939-001
Hinge covers	933394-001



IMPORTANT: Make special note of each screw and screw lock size and location during removal and replacement

Before removing the display panel, follow these steps:

1. Turn off the computer. If you are unsure whether the computer is off or in Hibernation, turn the computer on, and then shut it down through the operating system.
2. Disconnect the power from the computer by unplugging the power cord from the computer.
3. Disconnect all external devices from the computer.
4. Remove the base enclosure ([Base enclosure on page 26](#)).
5. Remove the battery (see [Battery on page 28](#)).
6. Remove the following components:
 - a. Base enclosure (see [Base enclosure on page 26](#)).
 - b. Battery (see [Battery on page 28](#)).

Remove the display assembly:

- ▲ Remove three screws from each hinge bracket **(1)**, turn the display assembly over **(2)**, and then lift the display to remove it **(e)**.

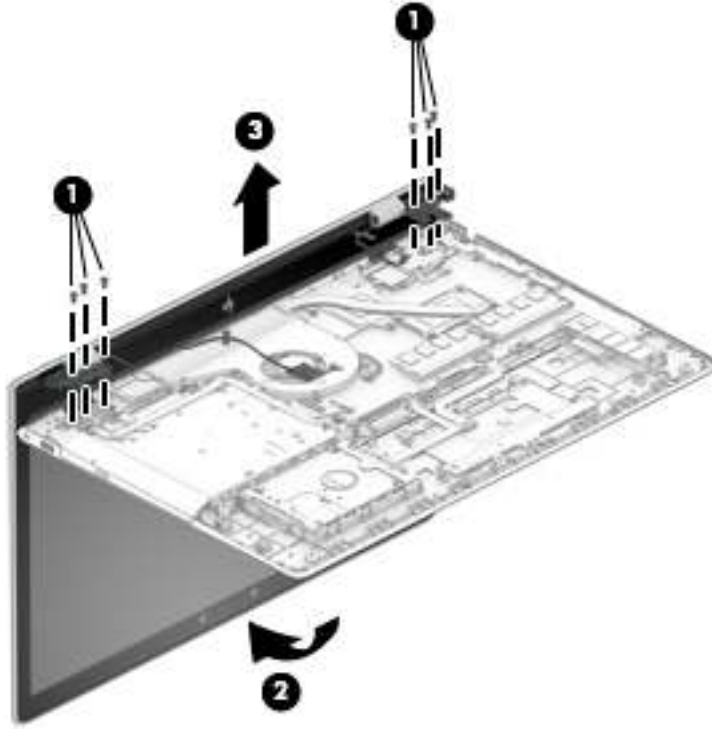

Reverse this procedure to replace the display assembly.

Hard drive

Description	Spare part number
Hard drive, 1TB 7200 RPM SATA RAW 9.5mm	766644-005
Cable, hard drive	925456-001
Rubber, sleeve holder	925465-001

 **IMPORTANT:** Make special note of each screw and screw lock size and location during removal and replacement

Before removing the hard drive, follow these steps:

1. Shut down the computer.
2. Disconnect all external devices connected to the computer.
3. Disconnect the power from the computer by first unplugging the power cord from the AC outlet and then unplugging the AC adapter from the computer.
4. Remove the following components:
 - a. Base enclosure (see [Base enclosure on page 26](#)).
 - b. Battery (see [Battery on page 28](#)).

Remove the hard drive:

1. Disconnect the hard drive cable from the system board **(1)**.
2. Lift the hard drive cable **(2)**, and then lift the hard drive **(3)** to remove it.

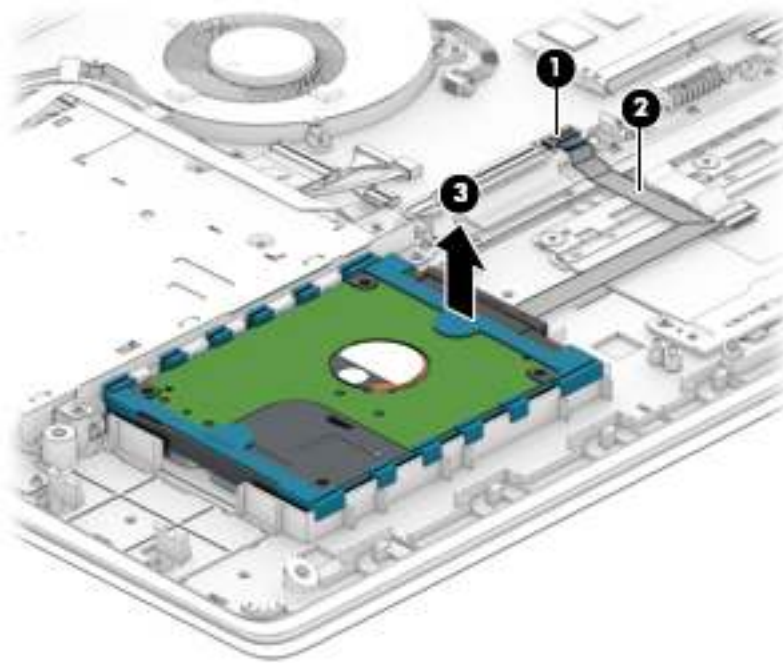

If it is necessary to disassemble the hard drive:

- ▲ Remove the hard drive cable **(1)**, remove the plastic hard drive bracket **(2)**, and then lift the hard drive bracket **(3)** to remove it.

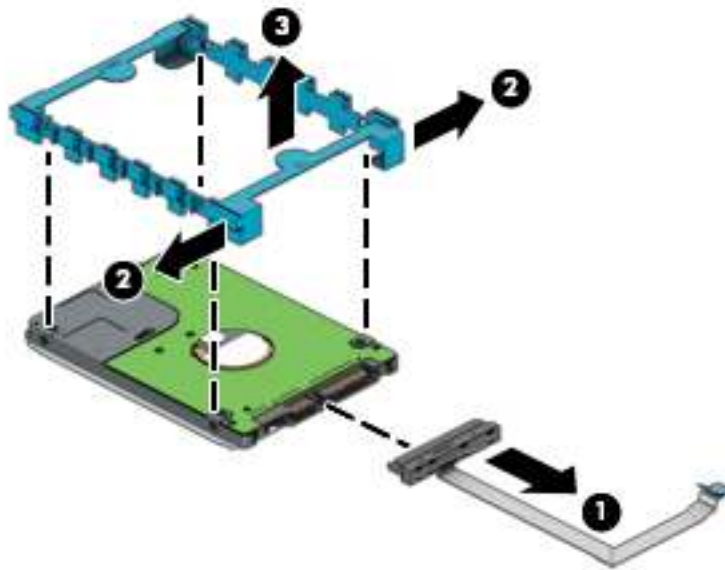

Reverse this procedure to install the hard drive.

Solid-state drive

Description	Spare part number
Solid-state drive	
SSD128 GB 2280 M2 SATA3 Value RS	827560-043
SSD 256 GB 2280 M2 PCIe3x4SS NVMeTLC RS	847109-019
SSD 512 GB 2280 M2 PCIe3x4SS NVMeTLC RS	847110-016
SSD1 TB 2280 PCIe-3x4NVMe TLC 2Side RS	865697-008
SSD 360 GB 2280 PCIe3x4 NVMe TLC RS	917818-010
SSD 256 GB 2280 PCIe NVMe Value RS	933705-001
SSD 512 GB 2280 PCIe NVMe Value RS	933706-001

 **IMPORTANT:** Make special note of each screw and screw lock size and location during removal and replacement

Before removing the solid-state drive, follow these steps:

1. Shut down the computer.
2. Disconnect all external devices connected to the computer.
3. Disconnect the power from the computer by first unplugging the power cord from the AC outlet and then unplugging the AC adapter from the computer.
4. Remove the following components:
 - a. Base enclosure (see [Base enclosure on page 26](#)).
 - b. Battery (see [Battery on page 28](#)).
 - c. Hard drive (see [Hard drive on page 31](#)).

Remove the solid-state drive:

1. Remove the Phillips screw **(1)** that secures the solid-state drive to the system board.

2. Remove the solid-state drive (2) by pulling the drive away from the slot at an angle.

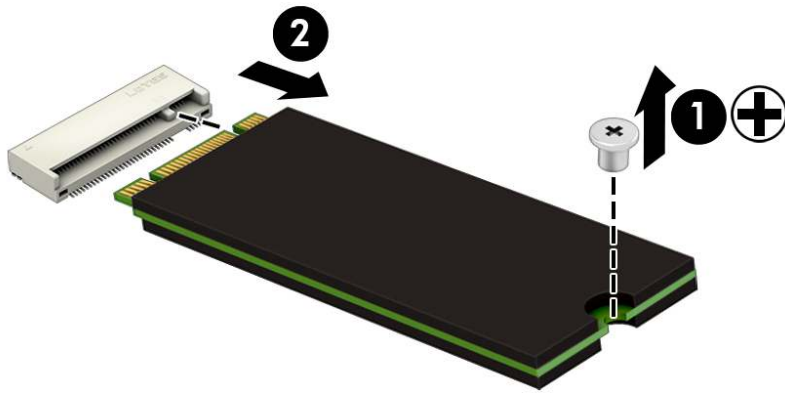

Reverse this procedure to install the solid-state drive.

Memory

Description	Spare part number
Memory	
SODIMM 4 GB 2400 MHz 1.2v DDR4	862397-855
SODIMM 8 GB 2400 MHz 1.2v DDR4	862398-855

 **IMPORTANT:** Make special note of each screw and screw lock size and location during removal and replacement

Before removing the memory, follow these steps:

1. Shut down the computer.
2. Disconnect all external devices connected to the computer.
3. Disconnect the power from the computer by first unplugging the power cord from the AC outlet and then unplugging the AC adapter from the computer.
4. Remove the following components:
 - a. Base enclosure (see [Base enclosure on page 26](#)).
 - b. Battery (see [Battery on page 28](#)).
 - c. Hard drive (see [Hard drive on page 31](#)).
 - d. Solid-state drive (see [Solid-state drive on page 33](#)).

Remove the memory:

1. Spread the retaining tabs **(1)** on each side of the memory module slot to release the memory module. (The memory module tilts up.)
2. Remove the memory module **(2)** by pulling the module away from the slot at an angle.

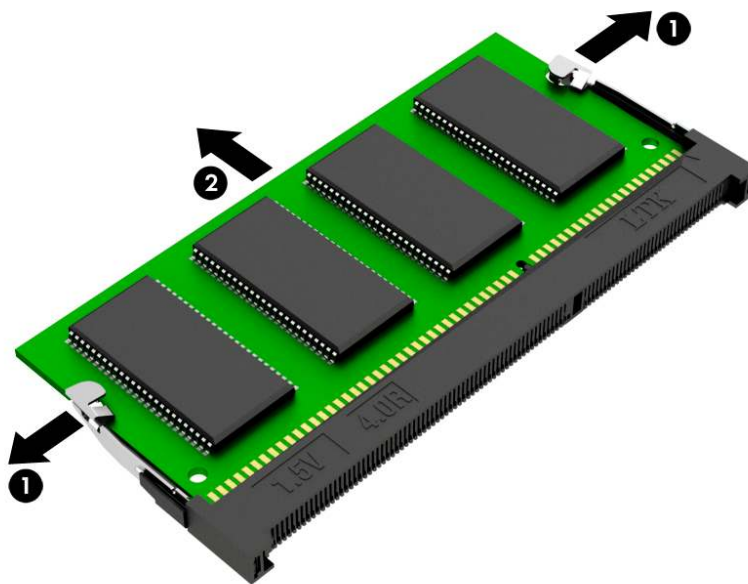

Reverse this procedure to install the memory.

WLAN module

Description	Spare part number
WLAN module	
11 AC+Bluetooth INT 7265NV M.2 D1 MOW	901229-855
RT CARTIER AC 2X2	924813-855

 **IMPORTANT:** Make special note of each screw and screw lock size and location during removal and replacement

 **CAUTION:** To prevent an unresponsive system, replace the wireless module only with a wireless module authorized for use in the computer by the governmental agency that regulates wireless devices in your country or region. If you replace the module and then receive a warning message, remove the module to restore device functionality, and then contact technical support.

Before removing the WLAN module, follow these steps:

1. Shut down the computer.
2. Disconnect all external devices connected to the computer.
3. Disconnect the power from the computer by first unplugging the power cord from the AC outlet and then unplugging the AC adapter from the computer.
4. Remove the following components:
 - a. Base enclosure (see [Base enclosure on page 26](#)).
 - b. Battery (see [Battery on page 28](#)).
 - c. Hard drive (see [Hard drive on page 31](#)).
 - d. Solid-state drive (see [Solid-state drive on page 33](#)).
 - e. Memory (see [Memory on page 35](#)).

Remove the WLAN module:

1. Disconnect the WLAN antenna cables **(1)** from the terminals on the WLAN module.

 **NOTE:** The WLAN antenna cable labeled “1” connects to the WLAN module “Main” terminal labeled “1”. The WLAN antenna cable labeled “2” connects to the WLAN module “Aux” terminal labeled “2”.

2. Remove the Phillips screw **(2)** that secures the WLAN module to the system board. (The WLAN module tilts up.)

3. Remove the WLAN module (3) by pulling the module away from the slot at an angle.

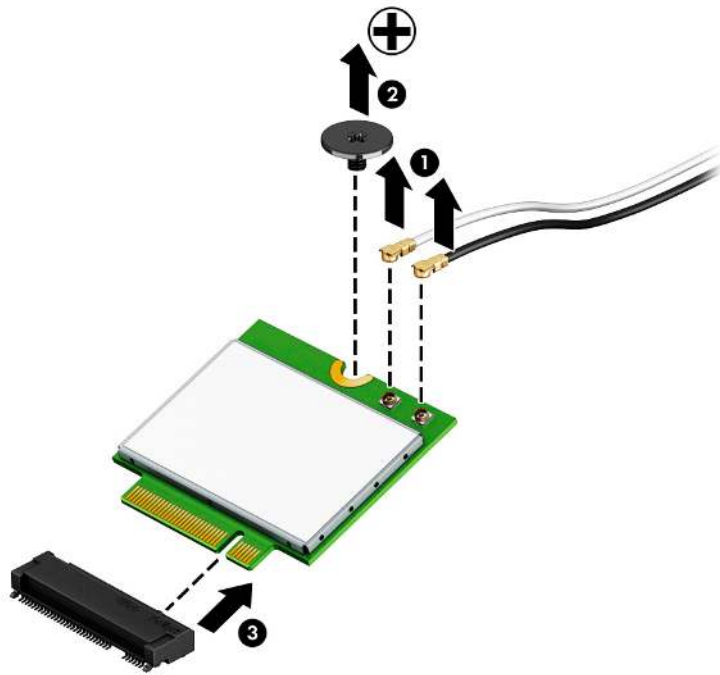

NOTE: If the WLAN antenna cables are not connected to the terminals on the WLAN module, protective sleeves should be installed on the antenna connectors, as shown in the following illustration.



Reverse this procedure to install the WLAN module.

Optical drive

Description	Spare part number
ODD DVD-Writer 9.0mm Tray	920417-005
Bracket, ODD left	925464-001
Bracket, ODD right	931742-001
Bezel, ODD	925455-001



IMPORTANT: Make special note of each screw and screw lock size and location during removal and replacement

Before removing the optical drive, follow these steps:

1. Shut down the computer.
2. Disconnect all external devices connected to the computer.
3. Disconnect the power from the computer by first unplugging the power cord from the AC outlet and then unplugging the AC adapter from the computer.
4. Remove the following components:
 - a. Base enclosure (see [Base enclosure on page 26](#)).
 - b. Battery (see [Battery on page 28](#)).
 - c. Hard drive (see [Hard drive on page 31](#)).
 - d. Solid-state drive (see [Solid-state drive on page 33](#)).
 - e. Memory (see [Memory on page 35](#)).
 - f. WLAN module (see [WLAN module on page 37](#)).

Remove the optical drive:

- ▲ Remove 3 screws **(1)**, disconnect the optical drive cable**(2)**, and then slide the optical drive out **(3)** to remove it.

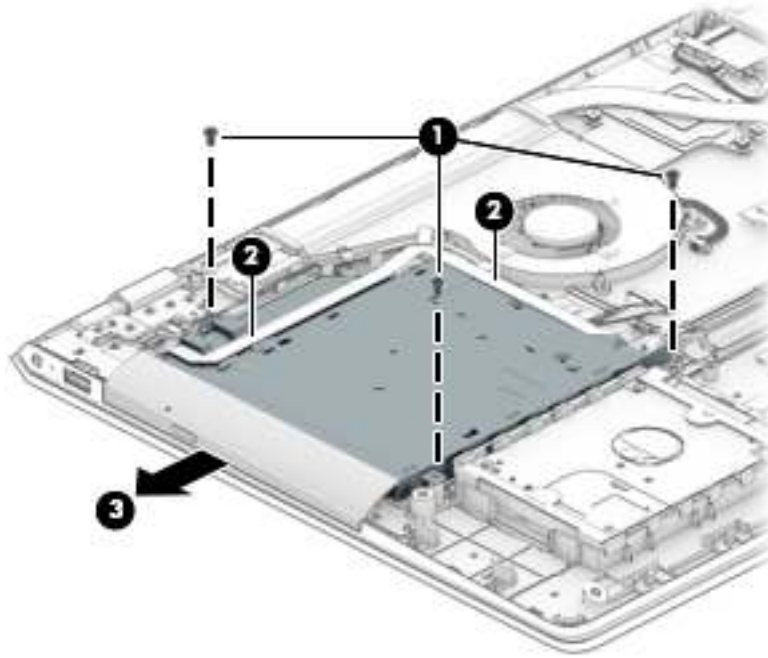

If it is necessary to remove the optical drive bracket:

- ▲ Remove 3 screws **(1)**, and then remove the optical drive brackets**(2)**.

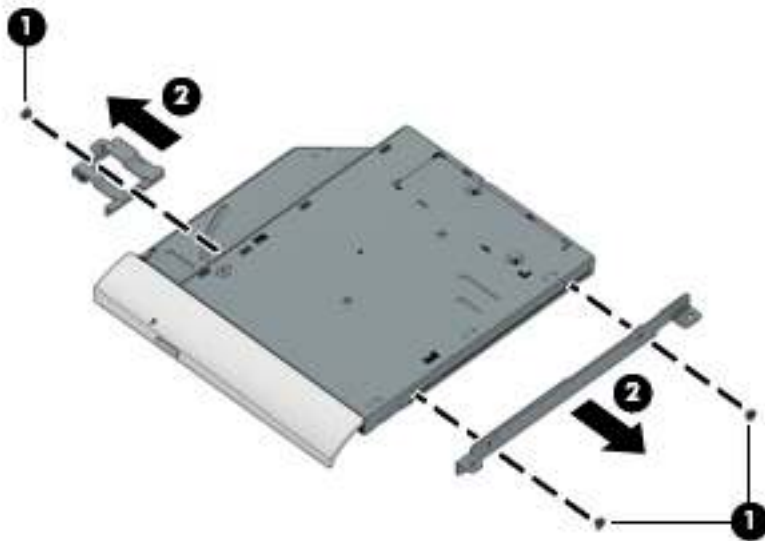

Reverse this procedure to install the optical drive.

Input/output brackets

Description	Spare part number
Bracket, right input/output	925462-001
Bracket, left input/output	925463-001



IMPORTANT: Make special note of each screw and screw lock size and location during removal and replacement

Before removing the Input/out brackets, follow these steps:

1. Shut down the computer.
2. Disconnect all external devices connected to the computer.
3. Disconnect the power from the computer by first unplugging the power cord from the AC outlet and then unplugging the AC adapter from the computer.
4. Remove the following components:
 - a. Base enclosure (see [Base enclosure on page 26](#)).
 - b. Battery (see [Battery on page 28](#)).
 - c. Hard drive (see [Hard drive on page 31](#)).
 - d. Solid-state drive (see [Solid-state drive on page 33](#)).
 - e. Memory (see [Memory on page 35](#)).
 - f. WLAN module (see [WLAN module on page 37](#)).
 - g. Optical drive (see [Optical drive on page 39](#)).

Remove the left input/output bracket:

1. Remove 1 screw **(1)**.

2. Remove 2 screws **(2)**, and then lift the left I/O bracket **(3)** to remove it.

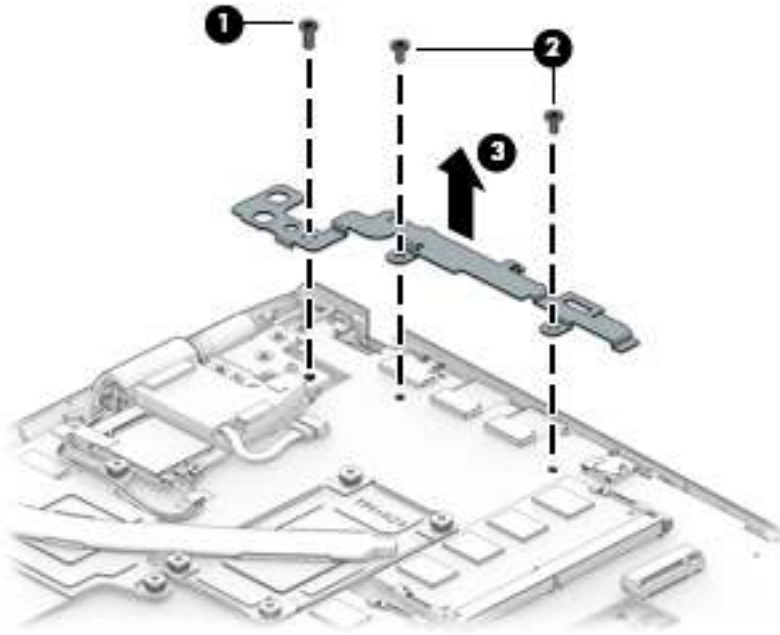

Remove the right input/output bracket:

- ▲ Remove 1 screw **(1)**, and then lift the right I/O bracket **(2)** to remove it.

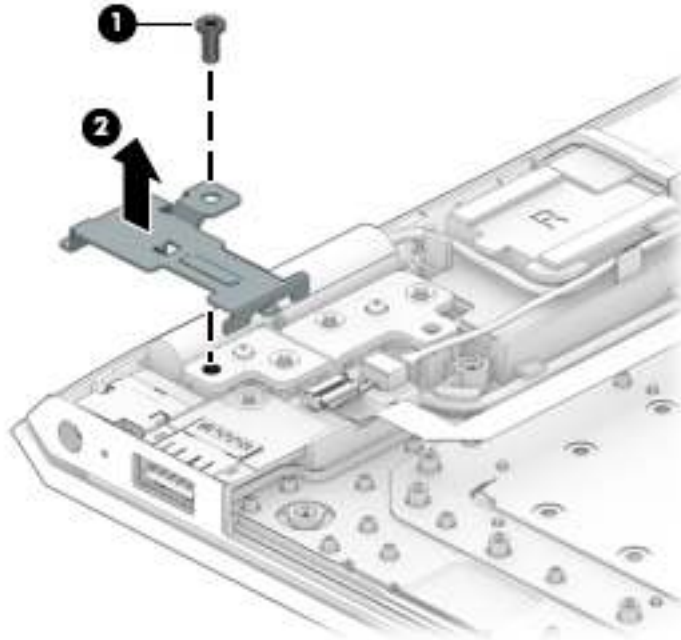

Reverse this procedure to install the input/output brackets.

Fan

Description	Spare part number
Fan	925461-001
Heat sink	925478-001



IMPORTANT: Make special note of each screw and screw lock size and location during removal and replacement

Before removing the fan, follow these steps:

1. Shut down the computer.
2. Disconnect all external devices connected to the computer.
3. Disconnect the power from the computer by first unplugging the power cord from the AC outlet and then unplugging the AC adapter from the computer.
4. Remove the following components:
 - a. Base enclosure (see [Base enclosure on page 26](#)).
 - b. Battery (see [Battery on page 28](#)).
 - c. Hard drive (see [Hard drive on page 31](#)).
 - d. Solid-state drive (see [Solid-state drive on page 33](#)).
 - e. Memory (see [Memory on page 35](#)).
 - f. WLAN module (see [WLAN module on page 37](#)).
 - g. Optical drive (see [Optical drive on page 39](#)).

Remove the fan:

1. Disconnect the fan cable from the system board **(1)**.
2. Remove 3 screws **(2)**.

3. Release the fan cable from the routing **(3)**, and then lift the fan **(4)** to remove it.

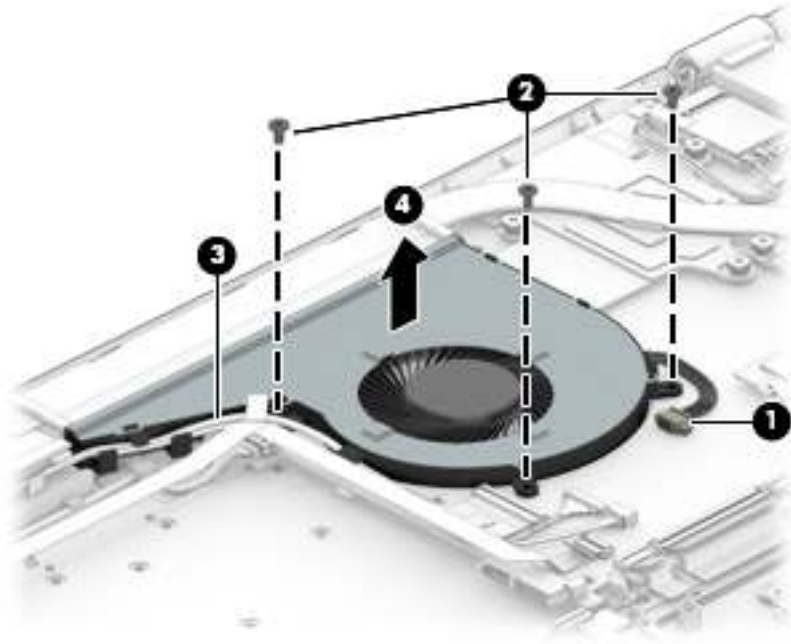

Reverse this procedure to install the fan.

TouchPad

Description	Spare part number
TouchPad	935941-001
TouchPad bracket	925466-001



IMPORTANT: Make special note of each screw and screw lock size and location during removal and replacement

Before removing the TouchPad, follow these steps:

1. Shut down the computer.
2. Disconnect all external devices connected to the computer.
3. Disconnect the power from the computer by first unplugging the power cord from the AC outlet and then unplugging the AC adapter from the computer.
4. Remove the following components:
 - a. Base enclosure (see [Base enclosure on page 26](#)).
 - b. Battery (see [Battery on page 28](#)).
 - c. Hard drive (see [Hard drive on page 31](#)).
 - d. Solid-state drive (see [Solid-state drive on page 33](#)).
 - e. Memory (see [Memory on page 35](#)).
 - f. WLAN module (see [WLAN module on page 37](#)).
 - g. Optical drive (see [Optical drive on page 39](#)).

Remove the TouchPad:

1. Remove 4 screws **(1)**, and then lift the bracket **(2)** to remove it.

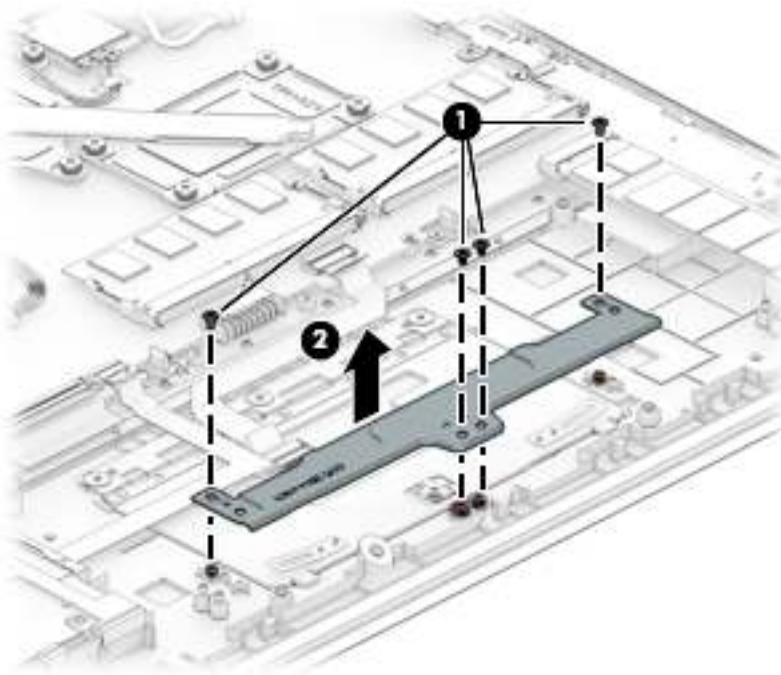

2. Disconnect the TouchPad cable **(1)**, and then release the cable **(2)**.
3. Remove 3 screws **(3)**, and then lift the TouchPad **(4)** to remove it.

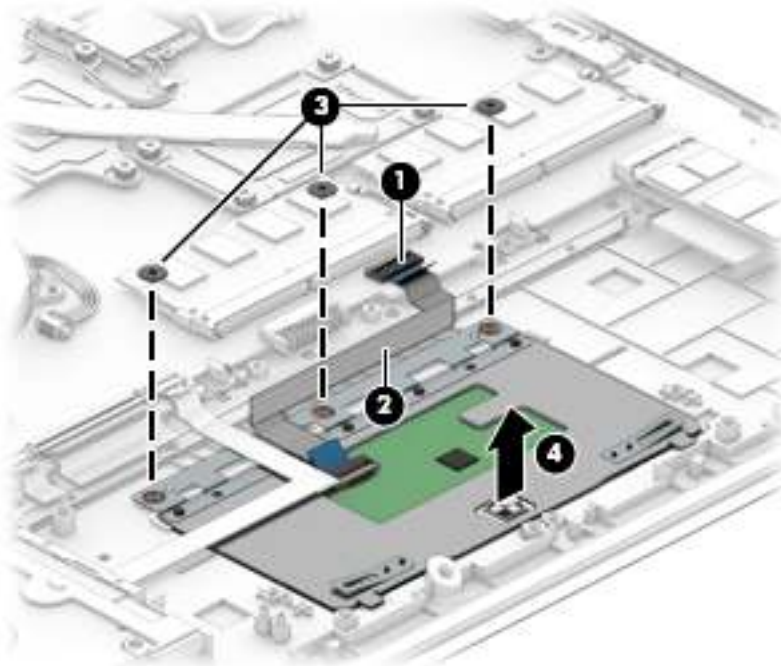

4. Disconnect the TouchPad cable from the system board (1) and the TouchPad (2), release the cable (3), and then lift the TouchPad cable (4) to remove it.

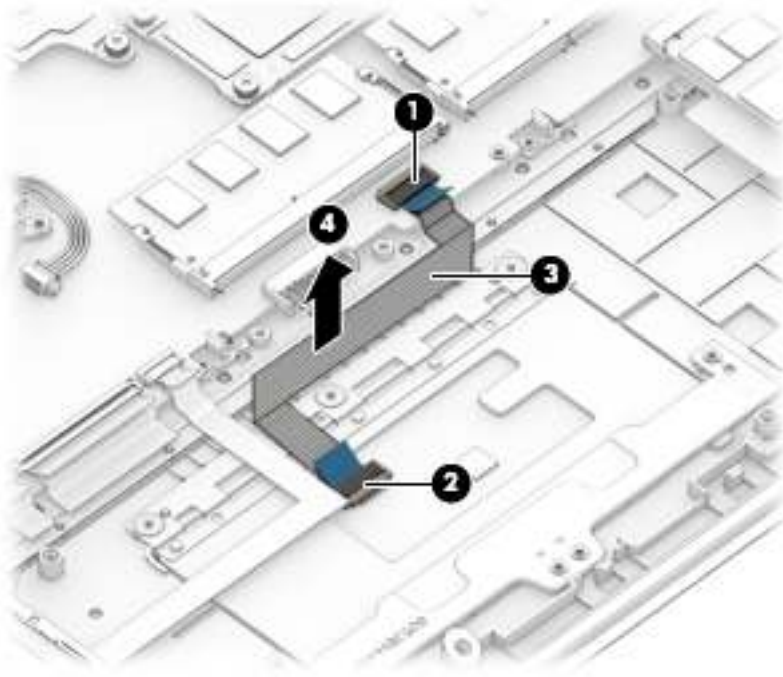

Reverse this procedure to install the TouchPad.

USB board

Description	Spare part number
USB board, 8L	925470-001
USB board, 10L	L02141-001
Cable, USB FFC	928573-001
Cable, USB	925458-001



IMPORTANT: Make special note of each screw and screw lock size and location during removal and replacement

Before removing the USB board, follow these steps:

1. Shut down the computer.
2. Disconnect all external devices connected to the computer.
3. Disconnect the power from the computer by first unplugging the power cord from the AC outlet and then unplugging the AC adapter from the computer.
4. Remove the following components:
 - a. Base enclosure (see [Base enclosure on page 26](#)).
 - b. Battery (see [Battery on page 28](#)).
 - c. Hard drive (see [Hard drive on page 31](#)).
 - d. Solid-state drive (see [Solid-state drive on page 33](#)).
 - e. Memory (see [Memory on page 35](#)).
 - f. WLAN module (see [WLAN module on page 37](#)).
 - g. Optical drive (see [Optical drive on page 39](#)).
 - h. System board (see [System board on page 50](#)).

Remove the USB board:

1. Disconnect the webcam cable **(1)** and the USB cable **(2)** from the system board.
2. Release the cable from the routing **(3)**.
3. Release the USB cable from the tape holding it **(4)**.
4. Remove 1 screw **(5)**.

5. Lift the USB board to remove it **(6)**.

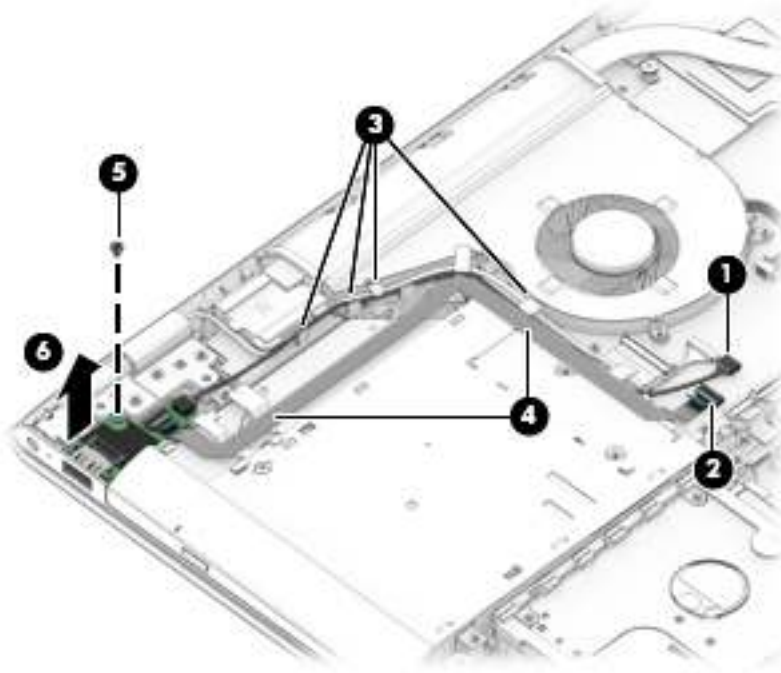

Reverse this procedure to install the USB board.

System board

Description	Spare part number
System board	
Discrete graphics 940MX 2 GB i5-7200U	925395-001
Discrete graphics 940MX 2 GB i5-7200U and the Windows operating system	925395-601
Discrete graphics 940MX 2 GB i7-7500U	925396-001
Discrete graphics 940MX 2 GB i7-7500U and the Windows operating system	925396-601
Discrete graphics 940MX 4 GB i7-7500U	925397-001
Discrete graphics 940MX 4 GB i7-7500U and the Windows operating system	925397-601
Discrete graphics MX150 2 GB i5-8250U	940818-001
Discrete graphics MX150 2 GB i5-8250U and the Windows operating system	940818-601
Discrete graphics MX150 2 GB i7-8550U	940819-001
Discrete graphics MX150 2 GB i7-8550U and the Windows operating system	940819-601
Discrete graphics MX150 4 GB i7-8550U	940820-001
Discrete graphics MX150 4 GB i7-8550U and the Windows operating system	940820-601



IMPORTANT: Make special note of each screw and screw lock size and location during removal and replacement

Before removing the system board, follow these steps:

1. Shut down the computer.
2. Disconnect all external devices connected to the computer.
3. Disconnect the power from the computer by first unplugging the power cord from the AC outlet and then unplugging the AC adapter from the computer.
4. Remove the following components:
 - a. Base enclosure (see [Base enclosure on page 26](#)).
 - b. Battery (see [Battery on page 28](#)).
 - c. Hard drive (see [Hard drive on page 31](#)).
 - d. Solid-state drive (see [Solid-state drive on page 33](#)).
 - e. Memory (see [Memory on page 35](#)).
 - f. WLAN module (see [WLAN module on page 37](#)).
 - g. Optical drive (see [Optical drive on page 39](#)).

Disconnect the following cables from the system board:

1. Panel cable **(1)**
2. Touch board **(2)**
3. Webcam cable and USB board cable**(3)**

4. USB board ribbon cable **(4)**
5. Backlit cable **(75)**
6. Keyboard cable **(6)**
7. Hard drive cable **(7)**
8. TouchPad cable **(8)**
9. WLAN antenna cable **(9)**
10. Speaker cable **(10)**

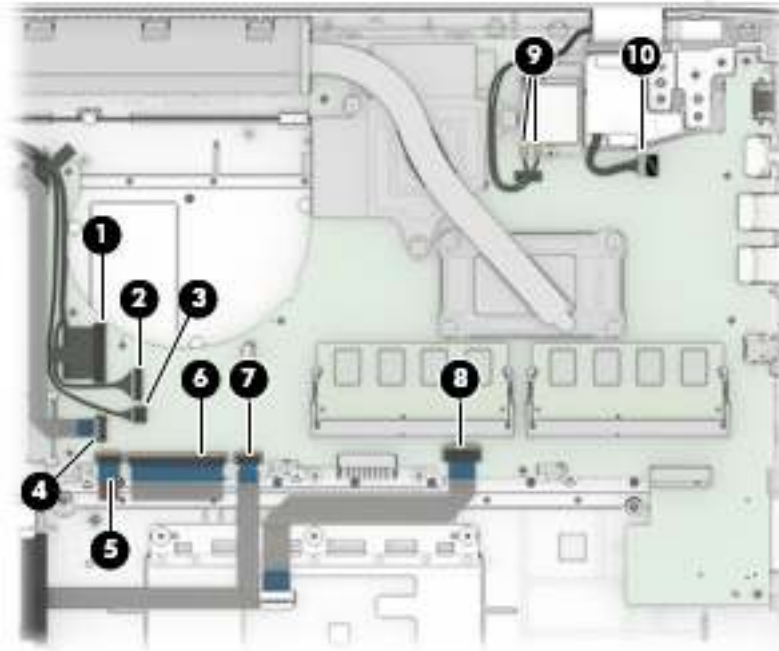

Remove the system board:

- ▲ Remove 6 screws **(1)**, lift the system board **(2)**, and then remove it **(3)**.

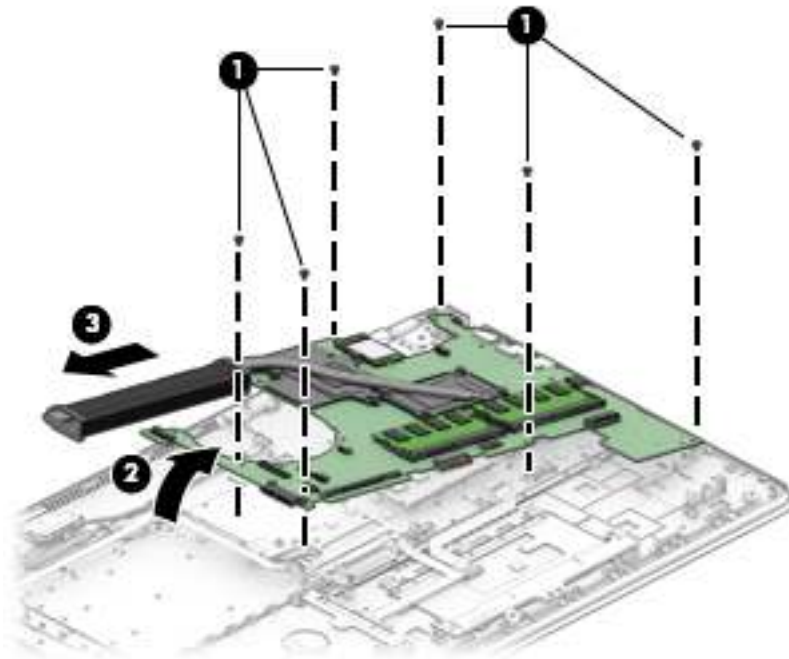

Reverse this procedure to install the system board.

Heat sink

Description	Spare part number
Heat sink	925478-001



IMPORTANT: Make special note of each screw and screw lock size and location during removal and replacement

Before removing the heat sink, follow these steps:

1. Shut down the computer.
2. Disconnect all external devices connected to the computer.
3. Disconnect the power from the computer by first unplugging the power cord from the AC outlet and then unplugging the AC adapter from the computer.
4. Remove the following components:
 - a. Base enclosure (see [Base enclosure on page 26](#)).
 - b. Battery (see [Battery on page 28](#)).
 - c. Hard drive (see [Hard drive on page 31](#)).
 - d. Solid-state drive (see [Solid-state drive on page 33](#)).
 - e. Memory (see [Memory on page 35](#)).
 - f. WLAN module (see [WLAN module on page 37](#)).
 - g. Optical drive (see [Optical drive on page 39](#)).
 - h. System board (see [System board on page 50](#)).

Remove the heat sink:

1. Remove 7 screws holding the heat sink **(1)** to the system board.

2. Lift the heat sink to remove it (2).

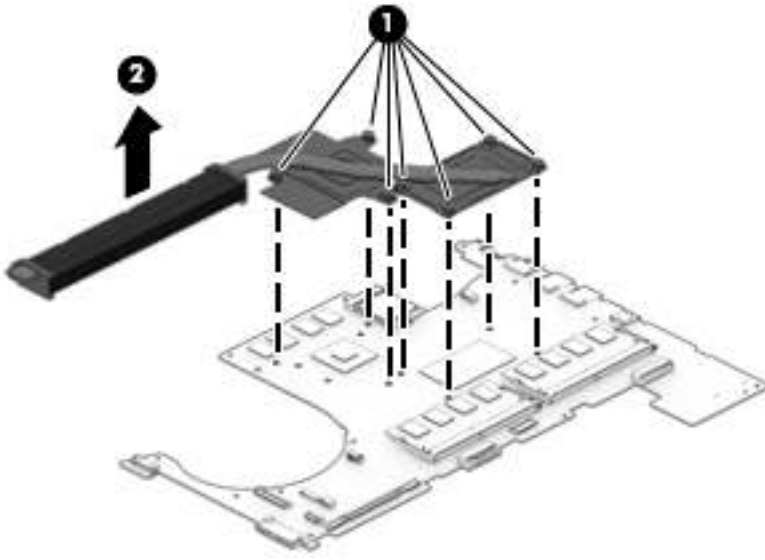

Thermal material locations are shown as follows:

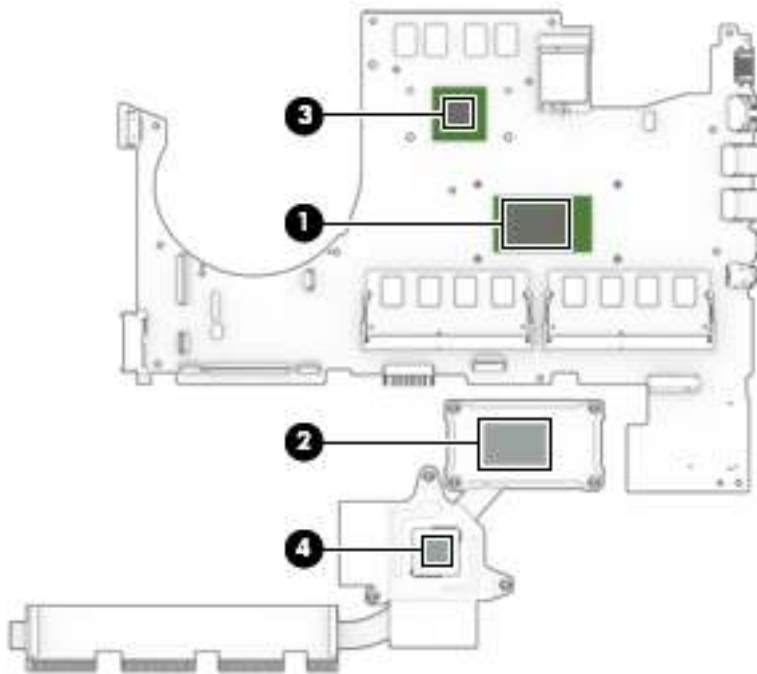

Reverse this procedure to install the heat sink.

Speakers

Description	Spare part number
Speaker Kit	925476-001



IMPORTANT: Make special note of each screw and screw lock size and location during removal and replacement

Before removing the speakers, follow these steps:

1. Shut down the computer.
2. Disconnect all external devices connected to the computer.
3. Disconnect the power from the computer by first unplugging the power cord from the AC outlet and then unplugging the AC adapter from the computer.
4. Remove the following components:
 - a. Base enclosure (see [Base enclosure on page 26](#)).
 - b. Battery (see [Battery on page 28](#)).
 - c. Hard drive (see [Hard drive on page 31](#)).
 - d. Solid-state drive (see [Solid-state drive on page 33](#)).
 - e. Memory (see [Memory on page 35](#)).
 - f. WLAN module (see [WLAN module on page 37](#)).
 - g. Optical drive (see [Optical drive on page 39](#)).
 - h. System board (see [System board on page 50](#)).

Remove the speakers:

1. Remove the tapes holding the speaker cable **(1)**.
2. Release the speaker cable from the routing **(2)**.
3. Release the display cable from the routing **(3)**.

4. Lift the speakers to remove them (4).

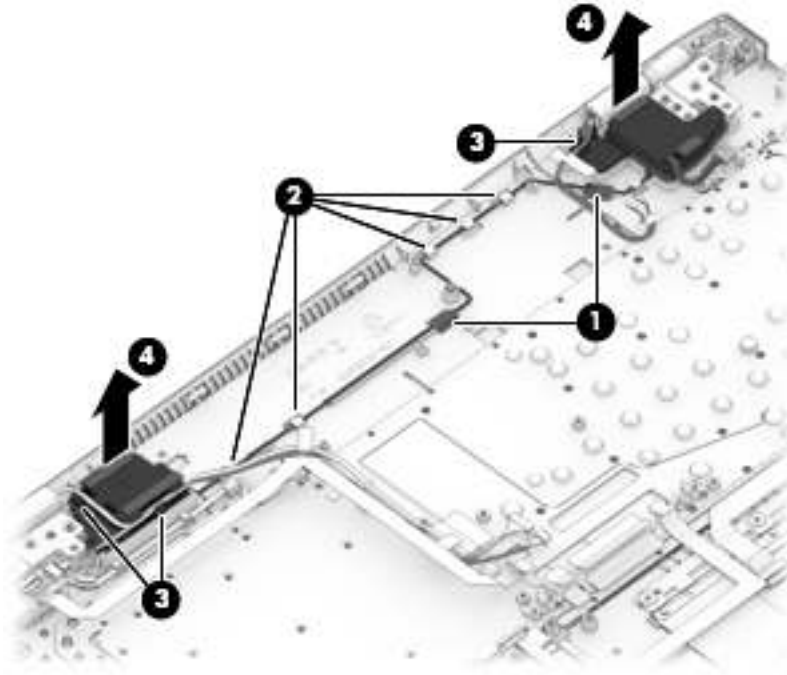

Reverse this procedure to install the speakers.

Power connector

Description	Spare part number
Power connector (includes cable)	810326-012



IMPORTANT: Make special note of each screw and screw lock size and location during removal and replacement

Before removing the speakers, follow these steps:

1. Shut down the computer.
2. Disconnect all external devices connected to the computer.
3. Disconnect the power from the computer by first unplugging the power cord from the AC outlet and then unplugging the AC adapter from the computer.
4. Remove the following components:
 - a. Base enclosure (see [Base enclosure on page 26](#)).
 - b. Battery (see [Battery on page 28](#)).
 - c. Hard drive (see [Hard drive on page 31](#)).
 - d. Solid-state drive (see [Solid-state drive on page 33](#)).
 - e. Memory (see [Memory on page 35](#)).
 - f. WLAN module (see [WLAN module on page 37](#)).
 - g. Optical drive (see [Optical drive on page 39](#)).
 - h. System board (see [System board on page 50](#)).

Remove the power connector:

1. Disconnect the power connector cable **(1)**.
2. Release the power connector cable from the routing **(2)**.

3. Lift the power connector to remove it (3).

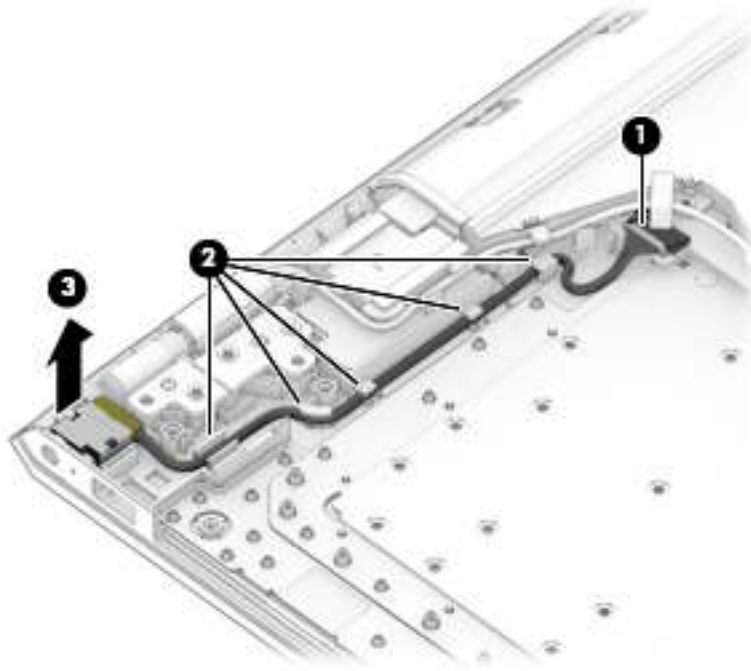

Reverse this procedure to install the power connector.

Top cover/keyboard

The top cover/keyboard spare part kit includes the top cover, keyboard, and keyboard cable.

For use in country or region	Spare part number	For use in country or region	Spare part number
For use in the United States	925477-001	For use in Russia	925477-251
For use in the United Kingdom	925477-031	For use in Romania	925477-271
For use in Germany	925477-041	For use in Belgium	925477-A41
For use in France	925477-051	For use internationally	925477-B31
For use in Italy	925477-061	For use in Slovenia	925477-BA1
For use in Spain	925477-071	For use in Israel	925477-BB1
For use in Portugal	925477-131	For use in Switzerland	925477-BG1
For use in Turkey	925477-141	For use in Canada	925477-DB1
For use in Greece	925477-151	For use in Denmark, Norway, Finland, and Sweden	925477-DH1
For use in Saudi Arabia	925477-171	For use in the Czech Republic and Slovakia	925477-FL1
For use in Hungary	925477-211		

The top cover/keyboard spare part remains after all other spare parts have been removed.

6 Using Setup Utility (BIOS)

Setup Utility, or Basic Input/Output System (BIOS), controls communication between all the input and output devices on the system (such as disk drives, display, keyboard, mouse, and printer). Setup Utility (BIOS) includes settings for the types of devices installed, the startup sequence of the computer, and the amount of system and extended memory.

 **NOTE:** To start Setup Utility on convertible computers, your computer must be in notebook mode and you must use the keyboard attached to your notebook.

Starting Setup Utility (BIOS)

 **CAUTION:** Use extreme care when making changes in Setup Utility (BIOS). Errors can prevent the computer from operating properly.

- ▲ Turn on or restart the computer, quickly press **esc**, and then press **f10**.

Updating Setup Utility (BIOS)

Updated versions of Setup Utility (BIOS) may be available on the HP website.

Most BIOS updates on the HP website are packaged in compressed files called *SoftPaqs*.

Some download packages contain a file named *Readme.txt*, which contains information regarding installing and troubleshooting the file.

Determining the BIOS version

To decide whether you need to update Setup Utility (BIOS), first determine the BIOS version on your computer.

To reveal the BIOS version information (also known as *ROM date* and *System BIOS*), use one of these options.

- HP Support Assistant
 1. Type `support` in the taskbar search box, and then select the **HP Support Assistant** app.
– or –
Click the question mark icon in the taskbar.
 2. Select **My PC**, and then select **Specifications**.
- Setup Utility (BIOS)
 1. Start Setup Utility (BIOS) (see [Starting Setup Utility \(BIOS\) on page 59](#)).
 2. Select **Main**, select **System Information**, and then make note of the BIOS version.
 3. Select **Exit**, select **No**, and then follow the on-screen instructions.

To check for later BIOS versions, see [Downloading a BIOS update on page 60](#).

Downloading a BIOS update

 **CAUTION:** To reduce the risk of damage to the computer or an unsuccessful installation, download and install a BIOS update only when the computer is connected to reliable external power using the AC adapter. Do not download or install a BIOS update while the computer is running on battery power, docked in an optional docking device, or connected to an optional power source. During the download and installation, follow these instructions:

- Do not disconnect power from the computer by unplugging the power cord from the AC outlet.
- Do not shut down the computer or initiate Sleep.
- Do not insert, remove, connect, or disconnect any device, cable, or cord.

 **NOTE:** If your computer is connected to a network, consult the network administrator before installing any software updates, especially system BIOS updates.

1. Type `support` in the taskbar search box, and then select the **HP Support Assistant** app.
– or –
Click the question mark icon in the taskbar.
2. Click **Updates**, and then click **Check for updates and messages**.
3. Follow the on-screen instructions.
4. At the download area, follow these steps:
 - a. Identify the most recent BIOS update and compare it to the BIOS version currently installed on your computer. If the update is more recent than your BIOS version, make a note of the date, name, or other identifier. You may need this information to locate the update later, after it has been downloaded to your hard drive.
 - b. Follow the on-screen instructions to download your selection to the hard drive.

Make a note of the path to the location on your hard drive where the BIOS update is downloaded. You will need to access this path when you are ready to install the update.

BIOS installation procedures vary. Follow any instructions that appear on the screen after the download is complete. If no instructions appear, follow these steps:

1. Type `file` in the taskbar search box, and then select **File Explorer**.
2. Click your hard drive designation. The hard drive designation is typically Local Disk (C:).
3. Using the hard drive path you recorded earlier, open the folder that contains the update.
4. Double-click the file that has an `.exe` extension (for example, `filename.exe`).

The BIOS installation begins.
5. Complete the installation by following the on-screen instructions.

 **NOTE:** After a message on the screen reports a successful installation, you can delete the downloaded file from your hard drive.

7 Using HP PC Hardware Diagnostics (UEFI)

HP PC Hardware Diagnostics is a Unified Extensible Firmware Interface (UEFI) that allows you to run diagnostic tests to determine whether the computer hardware is functioning properly. The tool runs outside the operating system so that it can isolate hardware failures from issues that are caused by the operating system or other software components.

When HP PC Hardware Diagnostics (UEFI) detects a failure that requires hardware replacement, a 24-digit Failure ID code is generated. This ID code can then be provided to support to help determine how to correct the problem.

 **NOTE:** To start diagnostics on a convertible computer, your computer must be in notebook mode and you must use the keyboard attached.

To start HP PC Hardware Diagnostics (UEFI), follow these steps:

1. Turn on or restart the computer, and quickly press **esc**.
2. Press **f2**.

The BIOS searches three places for the diagnostic tools, in the following order:

- a. Connected USB drive

 **NOTE:** To download the HP PC Hardware Diagnostics (UEFI) tool to a USB drive, see [Downloading HP PC Hardware Diagnostics \(UEFI\) to a USB device on page 62](#).

- b. Hard drive
- c. BIOS

3. When the diagnostic tool opens, select the type of diagnostic test you want to run, and then follow the on-screen instructions.

 **NOTE:** If you need to stop a diagnostic test, press **esc**.

Downloading HP PC Hardware Diagnostics (UEFI) to a USB device



NOTE: The HP PC Hardware Diagnostics (UEFI) download instructions are provided in English only, and you must use a Windows computer to download and create the HP UEFI support environment because only .exe files are offered.

There are two options to download HP PC Hardware Diagnostics to a USB device.

Download the latest UEFI version

1. Go to <http://www.hp.com/go/techcenter/pcdiags>. The HP PC Diagnostics home page is displayed.
2. In the HP PC Hardware Diagnostics section, select the **Download** link, and then select **Run**.

Download any version of UEFI for a specific product

1. Go to <http://www.hp.com/support>.
2. Select **Get software and drivers**.
3. Enter the product name or number.
4. Select your computer, and then select your operating system.
5. In the **Diagnostic** section, follow the on-screen instructions to select and download the UEFI version you want.

8 Backing up, restoring, and recovering

This chapter provides information about the following processes. The information in the chapter is standard procedure for most products.

- Creating recovery media and backups
- Restoring and recovering your system

For additional information, refer to the HP Support Assistant app.

- ▲ Type `support` in the taskbar search box, and then select the **HP Support Assistant** app.

– or –

Select the question mark icon in the taskbar.

 **IMPORTANT:** If you will be performing recovery procedures on a tablet, the tablet battery must be at least 70% charged before you start the recovery process.

IMPORTANT: For a tablet with a detachable keyboard, connect the tablet to the keyboard base before beginning any recovery process.

Creating recovery media and backups

The following methods of creating recovery media and backups are available on select products only. Choose the available method according to your computer model.

- Use HP Recovery Manager to create HP Recovery media after you successfully set up the computer. This step creates a backup of the HP Recovery partition on the computer. The backup can be used to reinstall the original operating system in cases where the hard drive is corrupted or has been replaced. For information on creating recovery media, see [Using HP Recovery media \(select products only\) on page 63](#). For information on the recovery options that are available using the recovery media, see [Using Windows tools on page 64](#).
- Use Windows tools to create system restore points and create backups of personal information. See [Using Windows tools on page 64](#).

 **NOTE:** If storage is 32 GB or less, Microsoft System Restore is disabled by default.

- On select products, use the HP Cloud Recovery Download Tool to create a bootable USB flash drive for your HP recovery media. For more information, see [Using the HP Cloud Recovery Download Tool \(select products only\) on page 65](#).

Using HP Recovery media (select products only)

If possible, check for the presence of the Recovery partition and the Windows partition. Right-click the **Start** button, select **File Explorer**, and then select **This PC**.

- If your computer does not list the Windows partition and the Recovery partition, you can obtain recovery media for your system from support. You can find contact information on the HP website. Go to <http://www.hp.com/support>, select your country or region, and follow the on-screen instructions.
- If your computer does list the Recovery partition and the Windows partition, you can use HP Recovery Manager to create recovery media after you successfully set up the computer. HP Recovery media can be

used to perform system recovery if the hard drive becomes corrupted. System recovery reinstalls the original operating system and software programs that were installed at the factory and then configures the settings for the programs. HP Recovery media can also be used to customize the system or restore the factory image if you replace the hard drive.

- Only one set of recovery media can be created. Handle these recovery tools carefully, and keep them in a safe place.
- HP Recovery Manager examines the computer and determines the required storage capacity for the media that will be required.
- To create recovery discs, your computer must have an optical drive with DVD writer capability, and you must use only high-quality blank DVD-R, DVD+R, DVD-R DL, or DVD+R DL discs. Do not use rewritable discs such as CD±RW, DVD±RW, double-layer DVD±RW, or BD-RE (rewritable Blu-ray) discs; they are not compatible with HP Recovery Manager software. Or, instead, you can use a high-quality blank USB flash drive.
- If your computer does not include an integrated optical drive with DVD writer capability, but you would like to create DVD recovery media, you can use an external optical drive (purchased separately) to create recovery discs. If you use an external optical drive, it must be connected directly to a USB port on the computer; the drive cannot be connected to a USB port on an external device, such as a USB hub. If you cannot create DVD media yourself, you can obtain recovery discs for your computer from HP. You can find contact information on the HP website. Go to <http://www.hp.com/support>, select your country or region, and follow the on-screen instructions.
- Be sure that the computer is connected to AC power before you begin creating the recovery media.
- The creation process can take an hour or more. Do not interrupt the creation process.
- If necessary, you can exit the program before you have finished creating all of the recovery DVDs. HP Recovery Manager will finish burning the current DVD. The next time you start HP Recovery Manager, you will be prompted to continue.

To create HP Recovery media using HP recovery manager:

 **IMPORTANT:** For a tablet with a detachable keyboard, connect the tablet to the keyboard base before beginning these steps.

1. Type `recovery` in the taskbar search box, and then select **HP Recovery Manager**.
2. Select **Create recovery media**, and then follow the on-screen instructions.

If you ever need to recover the system, see [Recovering using HP Recovery Manager on page 65](#).

Using Windows tools

You can create recovery media, system restore points, and backups of personal information using Windows tools.

 **NOTE:** If storage is 32 GB or less, Microsoft System Restore is disabled by default.

For more information and steps, see the Get Help app.

- ▲ Select the **Start** button, and then select the **Get Help** app.

 **NOTE:** You must be connected to the Internet to access the Get Help app.

Using the HP Cloud Recovery Download Tool (select products only)

To create HP Recovery media using the HP Cloud Recovery Download Tool:

1. Go to <http://www.hp.com/support>.
2. Select **Software and Drivers**, and then follow the on-screen instructions.

Restore and recovery

There are several options for recovering your system. Choose the method that best matches your situation and level of expertise:

 **IMPORTANT:** Not all methods are available on all products.

- Windows offers several options for restoring from backup, refreshing the computer, and resetting the computer to its original state. For more information see the Get Help app.
 - ▲ Select the **Start** button, and then select the **Get Help** app.

 **NOTE:** You must be connected to the Internet to access the Get Help app.

- If you need to correct a problem with a preinstalled application or driver, use the Reinstall drivers and/or applications option (select products only) of HP Recovery Manager to reinstall the individual application or driver.
 - ▲ Type `recovery` in the taskbar search box, select **HP Recovery Manager**, select **Reinstall drivers and/or applications**, and then follow the on-screen instructions.
- If you want to recover the Windows partition to original factory content, you can choose the System Recovery option from the HP Recovery partition (select products only) or use the HP Recovery media. For more information, see [Recovering using HP Recovery Manager on page 65](#). If you have not already created recovery media, see [Using HP Recovery media \(select products only\) on page 63](#).
- On select products, if you want to recover the computer's original factory partition and content, or if you have replaced the hard drive, you can use the Factory Reset option of HP Recovery media. For more information, see [Recovering using HP Recovery Manager on page 65](#).
- On select products, if you want to remove the Recovery partition to reclaim hard drive space, HP Recovery Manager offers the Remove Recovery Partition option.

For more information, see [Removing the HP Recovery partition \(select products only\) on page 67](#).

Recovering using HP Recovery Manager

HP Recovery Manager software allows you to recover the computer to its original factory state by using the HP Recovery media that you either created or that you obtained from HP, or by using the HP Recovery partition (select products only). If you have not already created recovery media, see [Using HP Recovery media \(select products only\) on page 63](#).

What you need to know before you get started

- HP Recovery Manager recovers only software that was installed at the factory. For software not provided with this computer, you must either download the software from the manufacturer's website or reinstall the software from the media provided by the manufacturer.

 **IMPORTANT:** Recovery through HP Recovery Manager should be used as a final attempt to correct computer issues.

- HP Recovery media must be used if the computer hard drive fails. If you have not already created recovery media, see [Using HP Recovery media \(select products only\) on page 63](#).
- To use the Factory Reset option (select products only), you must use HP Recovery media. If you have not already created recovery media, see [Using HP Recovery media \(select products only\) on page 63](#).
- If your computer does not allow the creation of HP Recovery media or if the HP Recovery media does not work, you can obtain recovery media for your system from support. You can find contact information from the HP website. Go to <http://www.hp.com/support>, select your country or region, and follow the on-screen instructions.

 **IMPORTANT:** HP Recovery Manager does not automatically provide backups of your personal data. Before beginning recovery, back up any personal data you want to retain.

Using HP Recovery media, you can choose from one of the following recovery options:

 **NOTE:** Only the options available for your computer display when you start the recovery process.

- System Recovery—Reinstalls the original operating system, and then configures the settings for the programs that were installed at the factory.
- Factory Reset—Restores the computer to its original factory state by deleting all information from the hard drive and re-creating the partitions. Then it reinstalls the operating system and the software that was installed at the factory.

The HP Recovery partition (select products only) allows System Recovery only.

Using the HP Recovery partition (select products only)

The HP Recovery partition allows you to perform a system recovery without the need for recovery discs or a recovery USB flash drive. This type of recovery can be used only if the hard drive is still working.

To start HP Recovery Manager from the HP Recovery partition:

 **IMPORTANT:** For a tablet with a detachable keyboard, connect the tablet to the keyboard base before beginning these steps (select products only).

1. Type `recovery` in the taskbar search box, select **HP Recovery Manager**, and then select **Windows Recovery Environment**.

– or –

For computers or tablets with keyboards attached, press **f11** while the computer boots, or press and hold **f11** as you press the power button.

For tablets without keyboards:

- Turn on or restart the tablet, and then quickly hold down the volume up button; then select **f11**.

– or –

- Turn on or restart the tablet, and then quickly hold down the volume down button; then select **f11**.

2. Select **Troubleshoot** from the boot options menu.
3. Select **Recovery Manager**, and then follow the on-screen instructions.

Using HP Recovery media to recover

You can use HP Recovery media to recover the original system. This method can be used if your system does not have an HP Recovery partition or if the hard drive is not working properly.

1. If possible, back up all personal files.
2. Insert the HP Recovery media, and then restart the computer.

 **NOTE:** If the computer does not automatically restart in HP Recovery Manager, change the computer boot order. See [Changing the computer boot order on page 67](#).

3. Follow the on-screen instructions.

Changing the computer boot order

If your computer does not restart in HP Recovery Manager, you can change the computer boot order, which is the order of devices listed in BIOS where the computer looks for startup information. You can change the selection to an optical drive or a USB flash drive.

To change the boot order:

 **IMPORTANT:** For a tablet with a detachable keyboard, connect the tablet to the keyboard base before beginning these steps.

1. Insert the HP Recovery media.
2. Access the system **Startup** menu.

For computers or tablets with keyboards attached:

- ▲ Turn on or restart the computer or tablet, quickly press **esc**, and then press **f9** for boot options.

For tablets without keyboards:

- ▲ Turn on or restart the tablet, and then quickly hold down the volume up button; then select **f9**.

– or –

Turn on or restart the tablet, and then quickly hold down the volume down button; then select **f9**.

3. Select the optical drive or USB flash drive from which you want to boot.
4. Follow the on-screen instructions.

Removing the HP Recovery partition (select products only)

HP Recovery Manager software allows you to remove the HP Recovery partition to free up hard drive space.

 **IMPORTANT:** After you remove the HP Recovery partition, you will not be able to perform System Recovery or create HP Recovery media from the HP Recovery partition. So before you remove the Recovery partition, create HP Recovery media; see [Using HP Recovery media \(select products only\) on page 63](#).

 **NOTE:** The Remove Recovery Partition option is only available on products that support this function.

Follow these steps to remove the HP Recovery partition:

1. Type `recovery` in the taskbar search box, and then select **HP Recovery Manager**.
2. Select **Remove Recovery Partition**, and then follow the on-screen instructions.

9 Specifications

Computer specifications

	Metric	U.S.
Dimensions		
Width	41.6 cm	15.18 in
Depth	28.3 cm	10.15 in
Height (front to back)	2.33 cm	.89 in
Weight	2.9 or 3.05 kg (depending on configuration)	6.41 or 6.73 (depending on configuration)
Input power		
Operating voltage and current	19.5 V dc @ 3.33 A – 65 W 19 V dc @ 4.62 A – 90 W	
Temperature		
Operating	5°C to 35°C	41°F to 95°F
Nonoperating	-20°C to 60°C	-4°F to 140°F
Relative humidity (noncondensing)		
Operating	10% to 90%	
Nonoperating	5% to 95%	
Maximum altitude (unpressurized)		
Operating	-15 m to 3,048 m	-50 ft to 10,000 ft
Nonoperating	-15 m to 12,192 m	-50 ft to 40,000 ft
NOTE: Applicable product safety standards specify thermal limits for plastic surfaces. The device operates well within this range of temperatures.		

Display Specifications (17.3)

	Metric	U.S.
Dimensions		
Width	32.4 cm	12.8 in
Height	19.3 cm	7.6 in
Diagonal	35.56 cm	14.0 in
Brightness	300 nits, 72% color gamut	

	Metric	U.S.
	300 nits, 95% color gamut	
Backlight	FHD WLED (1920x1080 flat-flat (4.2mm) UWVA, eDP1.2 (DBCG)	
	FHD WLED AntiGlare (1920x1080) flat-flat (4.2mm) UWVA, eDP1.2 (DBTS)	
	UHD WLED AntiGlare (3840x2160) flat-flat (4.2mm) UWVA, eDP1.3+PSR (DBCG)	

Hard drive specifications

	1-TB*
Dimensions	
Height	9.5 mm
Length	100.4 mm
Width	69.9 mm
Weight	110 g
Interface type	SATA
Transfer rate	
Synchronous (maximum)	1.1 GB/sec
Security	ATA security
Seek times (typical read, including setting)	
Single track	1.5 ms
Average (read/write)	11/13 ms
Maximum	22 ms
Logical blocks	1,953,525,168
Disk rotational speed	7200 rpm
Operating temperature	0°C to 60°C (32°F to 140°F)
*1 TB = 1 trillion bytes when referring to hard drive storage capacity. Actual accessible capacity is less.	
**1 GB = 1 billion bytes when referring to hard drive storage capacity. Actual accessible capacity is less.	
NOTE: Certain restrictions and exclusions apply. Contact technical support for details.	

M.2 solid-state drive specifications

256-GB*	
Dimensions	
Height	1 mm
Length	50.8 mm
Width	28.9 mm
Weight	< 10 g
Interface type	ATA-7
Transfer rate	
Sequential Read	Up to 540 MB/s
Random Read	Up to 85K IOPs
Sequential Write	Up to 280 MB/s
Random Write	Up to 67K IOPs
Ready time, Maximum (to not busy)	1.0 s
Access times	
Logical	0.1
Total logical sectors	500,118,192
Operating temperature	
Operating	0° to 70°C (32°F to 158°F)
Non-operating	-55° to 90°C (-67°F to 194°F)
*1 GB = 1 billion bytes when referring to hard drive storage capacity. Actual accessible capacity is less.	
NOTE: Certain restrictions and exclusions apply. Contact technical support for details.	

M.2 solid-state drive specifications

	128-GB*	256-GB*
Dimensions		
Width	1 mm	1 mm
Length	50.8 mm	50.8 mm
Width	28.9 mm	28.9 mm
Weight	< 10 g	< 10 g
Interface type	ATA-7	ATA-7
Transfer rate		
Sequential Read	Up to 520 MB/s	Up to 535 MB/s
Random Read	Up to 60K IOPs	Up to 97K IOPs
Sequential Write	Up to 160 MB/s	Up to 515 MB/s
Random Write	Up to 34K IOPs	Up to 59K IOPs
Ready time, Maximum (to not busy)	1.0 s	1.0 s
Access times		
Logical	0.1 ms	0.1 ms
Total logical sectors	250,069,680	500,118,192
Operating temperature		
Operating	0° to 70°C (32°F to 158°F)	0° to 70°C (32°F to 158°F)
Non-operating	-40° to 85°C (-40°F to 185°F)	-40° to 85°C (-40°F to 185°F)
*1 GB = 1 billion bytes when referring to hard drive storage capacity. Actual accessible capacity is less.		
NOTE: Certain restrictions and exclusions apply. Contact technical support for details.		

M.2 PCIe solid-state drive specifications

	256-GB*	512-GB*	1-TB*
Dimensions			
Height	1 mm	1 mm	1 mm
Length	50.8 mm	50.8 mm	50.8 mm
Width	28.9 mm	28.9 mm	28.9 mm
Weight	< 10 g	< 10 g	< 10 g
Interface type	ATA-7	ATA-7	ATA-7
Transfer rate			
Sequential Read	Up to 2150 MB/s	Up to 2150 MB/s	Up to 2150 MB/s
Random Read	Up to 300,000 IOPs	Up to 300,000 IOPs	Up to 300,000 IOPs
Sequential Write	Up to 1260 MB/s	Up to 1550 MB/s	Up to 1550 MB/s
Random Write	Up to 100,000 IOPs	Up to 100,000 IOPs	Up to 100,000 IOPs
Ready time, Maximum (to not busy)	1.0 s	1.0 s	1.0 s
Access times			
Logical	0.1	0.1	0.1
Total logical sectors	500,118,192	1,000,215,216	1,500,336,388
Operating temperature			
Operating	0° to 70°C (32°F to 158°F)	0° to 70°C (32°F to 158°F)	0° to 70°C (32°F to 158°F)
Non-operating	-40° to 80°C (-40°F to 176°F)	-40° to 85°C (-40°F to 185°F)	-40° to 85°C (-40°F to 185°F)
*1 GB = 1 billion bytes when referring to hard drive storage capacity. Actual accessible capacity is less.			
NOTE: Certain restrictions and exclusions apply. Contact technical support for details.			

10 Power cord set requirements

The wide-range input feature of the computer permits it to operate from any line voltage from 100 to 120 V ac, or from 220 to 240 V ac.

The 3-conductor power cord set included with the computer meets the requirements for use in the country or region where the equipment is purchased.

Power cord sets for use in other countries or regions must meet the requirements of the country and region where the computer is used.

Requirements for all countries

The following requirements are applicable to all countries and regions:

- The length of the power cord set must be at least **1.0 m** (3.3 ft) and no more than **2.0 m** (6.5 ft).
- All power cord sets must be approved by an acceptable accredited agency responsible for evaluation in the country or region where the power cord set will be used.
- The power cord sets must have a minimum current capacity of 10 A and a nominal voltage rating of 125 or 250 V ac, as required by the power system of each country or region.
- The appliance coupler must meet the mechanical configuration of an EN 60 320/IEC 320 Standard Sheet C13 connector for mating with the appliance inlet on the back of the computer.

Requirements for specific countries and regions

Country/region	Accredited agency	Applicable note number
Argentina	IRAM	1
Australia	SAA	1
Austria	OVE	1
Belgium	CEBEC	1
Brazil	ABNT	1
Canada	CSA	2
Chile	IMQ	1
Denmark	DEMKO	1
Finland	FIMKO	1
France	UTE	1
Germany	VDE	1
India	ISI	1
Israel	SII	1
Italy	IMQ	1
Japan	JIS	3
The Netherlands	KEMA	1
New Zealand	SANZ	1
Norway	NEMKO	1
The People's Republic of China	CCC	4
Saudi Arabia	SASO	7
Singapore	PSB	1
South Africa	SABS	1
South Korea	KTL	5
Sweden	SEMKO	1
Switzerland	SEV	1
Taiwan	BSMI	6
Thailand	TISI	1
The United Kingdom	ASTA	1
The United States	UL	2

1. The flexible cord must be Type H05VV-F, 3-conductor, 0.75 mm² conductor size. Power cord set fittings (appliance coupler and wall plug) must bear the certification mark of the agency responsible for evaluation in the country or region where it will be used.
2. The flexible cord must be Type SVT/SJT or equivalent, No. 18 AWG, 3-conductor. The wall plug must be a two-pole grounding type with a NEMA 5-15P (15 A, 125 V ac) or NEMA 6-15P (15 A, 250 V ac) configuration. CSA or C-UL mark. UL file number must be on each element.

Country/region	Accredited agency	Applicable note number
3.	The appliance coupler, flexible cord, and wall plug must bear a “T” mark and registration number in accordance with the Japanese Dentori Law. The flexible cord must be Type VCTF, 3-conductor, 0.75 mm ² or 1.25 mm ² conductor size. The wall plug must be a two-pole grounding type with a Japanese Industrial Standard C8303 (7 A, 125 V ac) configuration.	
4.	The flexible cord must be Type RVV, 3-conductor, 0.75 mm ² conductor size. Power cord set fittings (appliance coupler and wall plug) must bear the CCC certification mark.	
5.	The flexible cord must be Type H05VV-F 3-conductor, 0.75 mm ² conductor size. KTL logo and individual approval number must be on each element. Corset approval number and logo must be printed on a flag label.	
6.	The flexible cord must be Type HVCTF 3-conductor, 1.25 mm ² conductor size. Power cord set fittings (appliance coupler, cable, and wall plug) must bear the BSMI certification mark.	
7.	For 127 V ac, the flexible cord must be Type SVT or SJT 3-conductor, 18 AWG, with plug NEMA 5-15P (15 A, 125 V ac), with UL and CSA or C-UL marks. For 240 V ac, the flexible cord must be Type H05VV-F 3-conductor, 0.75 mm ² or 1.00 mm ² conductor size, with plug BS 1363/A with BSI or ASTA marks.	

11 Recycling

When a non-rechargeable or rechargeable battery has reached the end of its useful life, do not dispose of the battery in general household waste. Follow the local laws and regulations in your area for battery disposal.

HP encourages customers to recycle used electronic hardware, HP original print cartridges, and rechargeable batteries. For more information about recycling programs, see the HP Web site at <http://www.hp.com/recycle>.

Index

A

- AC adapter
 - spare part numbers 18
- AC adapter and battery 5
- AC adapter, spare part numbers 18
- action keys
 - using 12
- airplane mode key 13
- audio, product description 2
- audio-out (headphone)/audio-in (microphone) jack, identifying 6

B

- backups 63
- base enclosure
 - removal 26
 - spare part number 18
 - spare part numbers 26
- battery
 - removal 28
 - spare part number 18
 - spare part numbers 28

BIOS

- determining version 59
- downloading an update 60
- starting the Setup Utility 59
- updating 59

boot order

- changing 67

buttons

- left TouchPad 9
- power 10
- right TouchPad 9

C

- camera
 - identifying 8
 - product description 2
- camera light, identifying 8
- caps lock light, identifying 10
- chipset, product description 1
- components
 - bottom 14
 - display 8
 - keyboard area 9

- left side 5
- right side 5
- computer major components 16
- computer specifications 68
- connector, power 5

D

- display panel
 - product description 1
- display specifications 68
- DisplayPort
 - identifying USB Type-C 6
- Dongle, USB-C to USB-A, spare part number 18
- drive light 6

E

- esc key, identifying 12
- Ethernet, product description 3
- external card
 - product description 3

F

- fan
 - removal 43
 - spare part numbers 18, 43
- fn key, identifying 12

G

- graphics, product description 1

H

- hard drive
 - removal 31
 - spare part number 18
 - spare part numbers 31
 - specifications 70
- HDMI port
 - identifying 6
- HDMI to VGA adapter, spare part number 18
- heat sink
 - removal 53
 - spare part number 18
 - spare part numbers 53

- hook, USB-C to USB-A, spare part number 18

- HP PC Hardware Diagnostics (UEFI)
 - using 61

- HP Recovery Manager
 - correcting boot problems 67
 - starting 66

HP Recovery media

- recovery 67
- using 63

HP Recovery partition

- recovery 66
- removing 67

I

- input
 - product description 3
- input bracket
 - removal 41
 - spare part numbers 41
- integrated numeric keypad, identifying 12
- internal card
 - product description 3
- internal microphones, identifying 8

J

jacks

- audio-out (headphone)/audio-in (microphone) 6
- network 6
- RJ-45 (network) 6

K

- keyboard
 - product description 3
- keyboard, spare part number 58
- keys
 - airplane mode 13
 - esc 12
 - fn 12
 - Windows 12

L

- labels
 - serial number 15
- lights
 - AC adapter and battery light 5
 - caps lock 10
 - drive 6
 - mute 10
 - power 10
 - RJ-45 (network) status 6

M

- M.2 solid-state drive
 - specifications 71, 72, 73
- mechanical
 - product description 3
- memory
 - removal 35
 - spare part numbers 18, 35
- memory card reader, identifying 6
- memory card, identifying 6
- memory module
 - product description 2
- microphone
 - product description 2
- minimized image recovery 66
- minimized image, creating 65
- model name 1
- mute light, identifying 10

N

- network jack, identifying 6

O

- operating system, product description 4
- optical drive
 - product description 2
 - removal 39
 - spare part number 18
 - spare part numbers 39
- optical drive eject button, identifying 5
- optical drive, identifying 5
- original system recovery 65
- output
 - product description 3
- output bracket
 - removal 41
 - spare part numbers 41

P

- pen, spare part number 18
- ports
 - HDMI 6
 - USB 3.x SuperSpeed 6
 - USB 3.x SuperSpeed port with HP Sleep and Charge 5
 - USB Type-C 6
- power button, identifying 10
- Power connector
 - spare part number 17
- power connector
 - removal 57
 - spare part numbers 57
- power connector, identifying 5
- power cord
 - requirements for all countries 74
 - requirements for specific countries and regions 75
 - set requirements 74
- power cord, spare part number 18, 19
- power lights, identifying 10
- power requirements, product description 3
- processor
 - product description 1
- product description
 - audio 2
 - camera 2
 - chipset 1
 - display panel 1
 - Ethernet 3
 - external card 3
 - graphics 1
 - input 3
 - internal card 3
 - keyboard 3
 - mechanical 3
 - memory module 2
 - microphone 2
 - operating system 4
 - optical drive 2
 - output 3
 - power requirements 3
 - processors 1
 - product name 1
 - security 4
 - sensor 3

- serviceability 4
- storage 2
- wireless 3

- product name 1
- product name and number, computer 15

R

- recover
 - options 65
- recovery
 - discs 64, 67
 - HP Recovery Manager 65
 - media 67
 - starting 66
 - supported discs 64
 - system 65
 - USB flash drive 67
 - using HP Recovery media 64
- recovery media
 - creating using HP Recovery Manager 64
 - using 63
- recovery partition
 - removing 67
- regulatory information 15
- removal/replacement
 - procedures 25
- RJ-45 (network) jack, identifying 6
- RJ-45 (network) status lights, identifying 6
- rubber kit, spare part number 19

S

- screw kit, spare part number 19
- security cable slot, identifying 6
- security, product description 4
- sensor, product description 3
- serial number 15
- serial number, computer 15
- serviceability, product description 4
- slots
 - memory card reader 6
 - security cable 6
- solid-state drive
 - removal 33
 - spare part number 18
 - spare part numbers 33

- speaker
 - removal 55
 - spare part numbers 55
- speakers
 - identifying 11
 - spare part number 17
- specifications
 - computer 68
 - display 68
 - hard drive 70
 - M.2 solid-state drive 71, 72, 73
- storage
 - product description 2
- supported discs, recovery 64
- system board
 - removal 50
 - spare part number 18
 - spare part numbers 50
- system information
 - locating 15
- system recovery 65
- system restore point
 - creating 64
- system restore point, creating 63

T

- top cover, spare part number 58
- TouchPad
 - buttons 9
 - removal 45
 - spare part numbers 17, 45
- TouchPad cable
 - spare part number 17
- TouchPad zone, identifying 9

U

- USB 3.x SuperSpeed port with HP Sleep and Charge, identifying 5
- USB 3.x SuperSpeed port, identifying 6
- USB board
 - removal 48
 - spare part number 17
 - spare part numbers 48
- USB Type-C port, identifying 6

V

- vents, identifying 14

W

- warranty period 15

- Windows
 - system restore point 63, 64
- Windows key, identifying 12
- Windows tools
 - using 64
- wireless, product description 3
- WLAN antennas, identifying 8
- WLAN module
 - removal 37
 - spare part numbers 18, 37