

ILLUSTRATED PARTS LIST

MODEL NUMBER ST 121E

PRODUCT NUMBER 961 83 00-01

MFG. ID. NUMBER 96183000101

**REPAIR PARTS SNOW THROWER - - MODEL NUMBER ST 121E (96183000101)
AUGER ASSEMBLY**

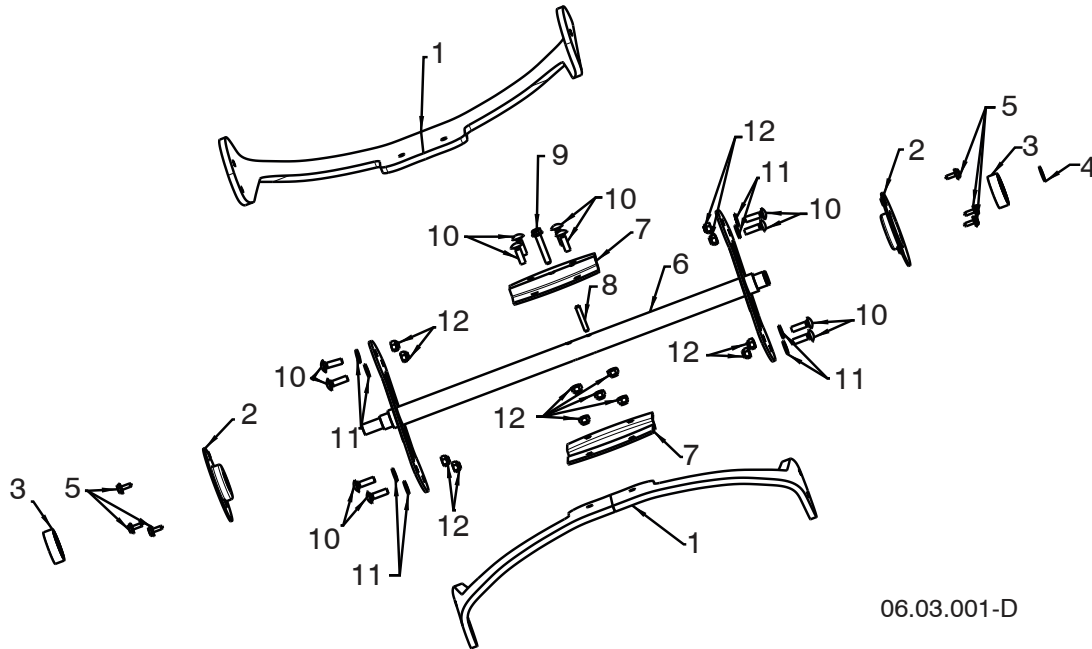

06.03.001-D

KEY NO.	PART NO.	DESCRIPTION
1	532 44 27-59	BLADE
2	580 85 55-01	BEARING SUPPORT
3	532 43 76-22	BALL BEARING
4	812 00 00-28	RETAINING RING
5	817 06 04-08	1/4-20 X 3/8 HEX SCREW
6	532 43 76-17	AUGER WELDMENT
7	580 85 54-01	CENTER BLADE PLATE
8	532 43 76-20	ROLL PIN
9	532 19 96-87	SCREW HEX WS HD 1/4-20 X 1.5
10	872 11 04-07	BOLT CARRIAGE 1/4-20 X 7/8
11	819 09 10-16	WASHER FLAT 1/4 SAE
12	532 13 20-04	NUT HEX 1/4-20 BZO

NOTE: All component dimensions given in U.S. inches. 1 inch = 25.4 mm
IMPORTANT: Use only Original Equipment Manufacturer (O.E.M.) replacement parts.
 Failure to do so could be hazardous, damage your snow thrower and void your warranty.

REPAIR PARTS SNOW THROWER - - MODEL NUMBER ST 121E (96183000101)

CHUTE ASSEMBLY

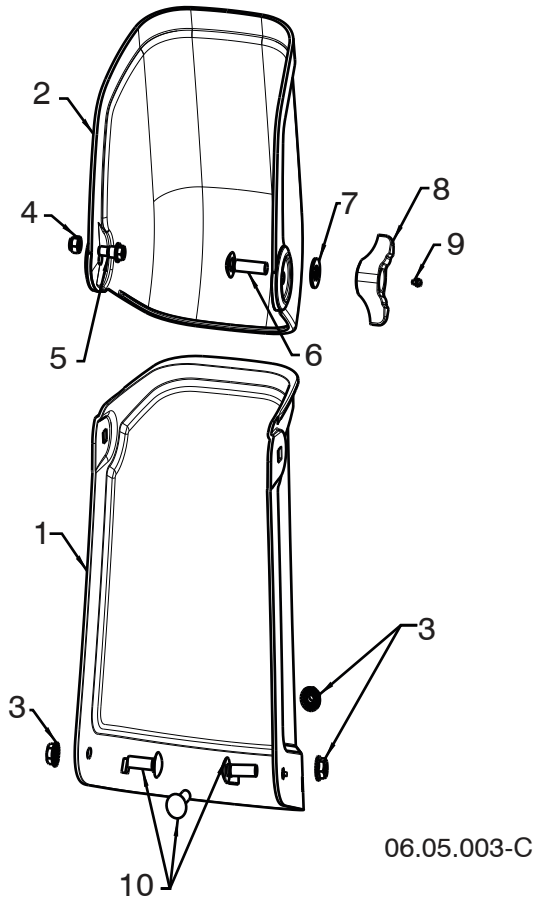

KEY NO.	PART NO.	DESCRIPTION
1	532 43 76-55	CHUTE (BLACK)
2	532 43 76-43	DEFLECTOR (BLACK)
3	873 97 05-00	NUT LOCK HEX W/INS 5/16-18 UNC PL
4	532 13 20-04	NUT HEX 1/4-20 NYLON LOCKING
5	532 44 46-82	SHOULDER BOLT 1/4-20 HEX HEAD
6	872 11 05-10	CARRIAGE BOLT 5/16-18 X 1-1/4
7	819 13 13-16	WASHER 13/32 X 13/16 X 16 GA
8	532 44 50-19	WING KNOB
9	532 07 16-73	CAP PLUNGER
10	872 01 05-06	CARRIAGE BOLT 5/16-18 UNC X 1

NOTE: All component dimensions given in U.S. inches. 1 inch = 25.4 mm
IMPORTANT: Use only Original Equipment Manufacturer (O.E.M.) replacement parts. Failure to do so could be hazardous, damage your snow thrower and void your warranty.

REPAIR PARTS SNOW THROWER - - MODEL NUMBER ST 121E (96183000101)

HANDLE ASSEMBLY

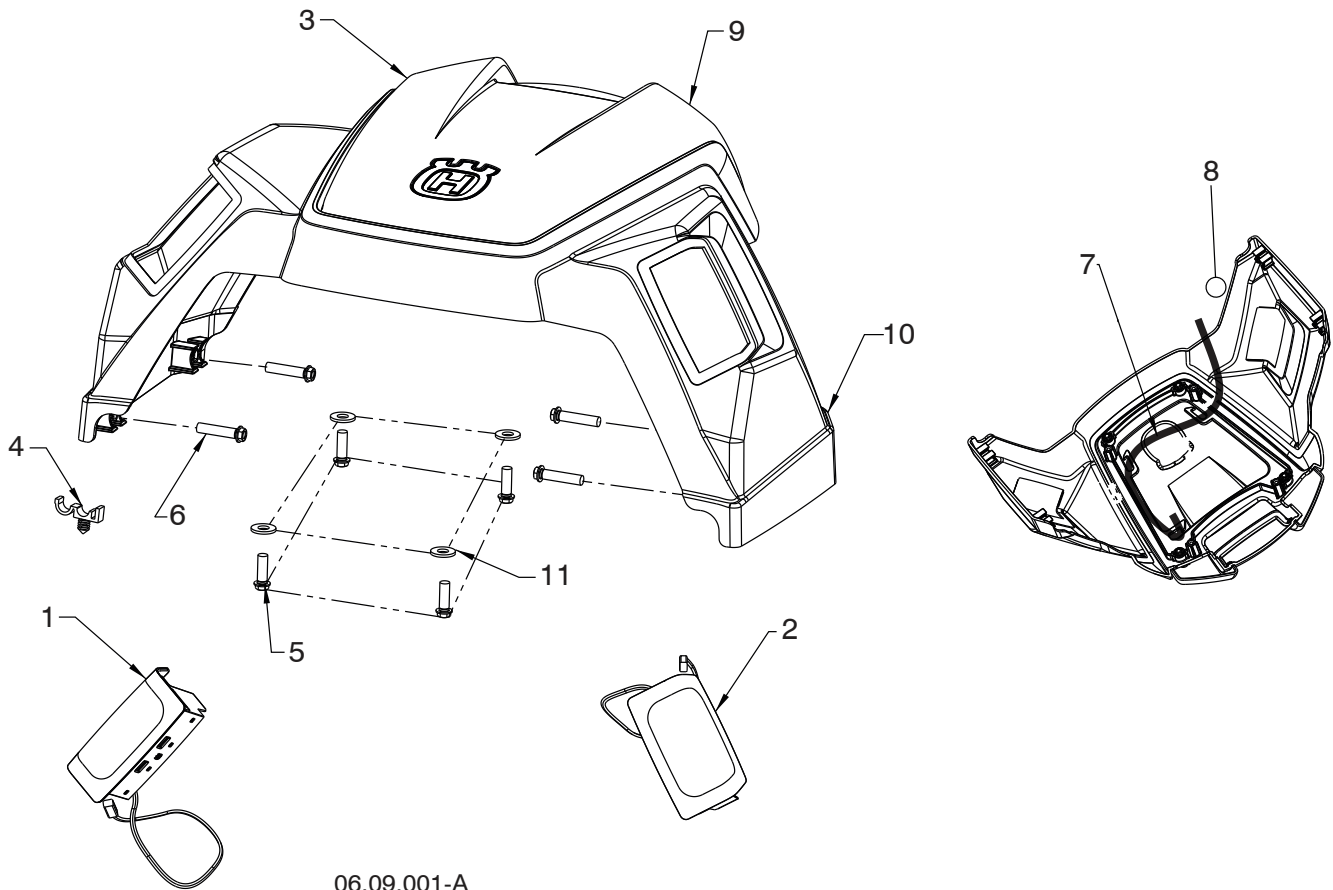

06.09.001-A

KEY NO.	PART NO.	DESCRIPTION
1	532 44 27-75	RH LED SUBASM
2	532 44 27-76	LH LED SUBASM
3	581 00 88-01	SHROUD CONTROL ASM
4	532 14 50-06	PUSH IN CLIP
5	817 41 13-12	SCREW HI-LO 3/4"
6	817 41 13-18	SCRWE HI-LO 1-1/8
7	532 44 30-46	WIRING HARNESS
8	580 40 21-01	HARNESS JUMPER
9	532 44 32-45	SHROUD ASM SM
10	532 44 16-24	SHROUD LARGE
11	819 09 10-16	WASHER FLAT 1/4 SAE

NOTE: All component dimensions given in U.S. inches. 1 inch = 25.4 mm
IMPORTANT: Use only Original Equipment Manufacturer (O.E.M.) replacement parts.
 Failure to do so could be hazardous, damage your snow thrower and void your warranty.

REPAIR PARTS SNOW THROWER - - MODEL NUMBER ST 121E (96183000101)

HANDLE ASSEMBLY

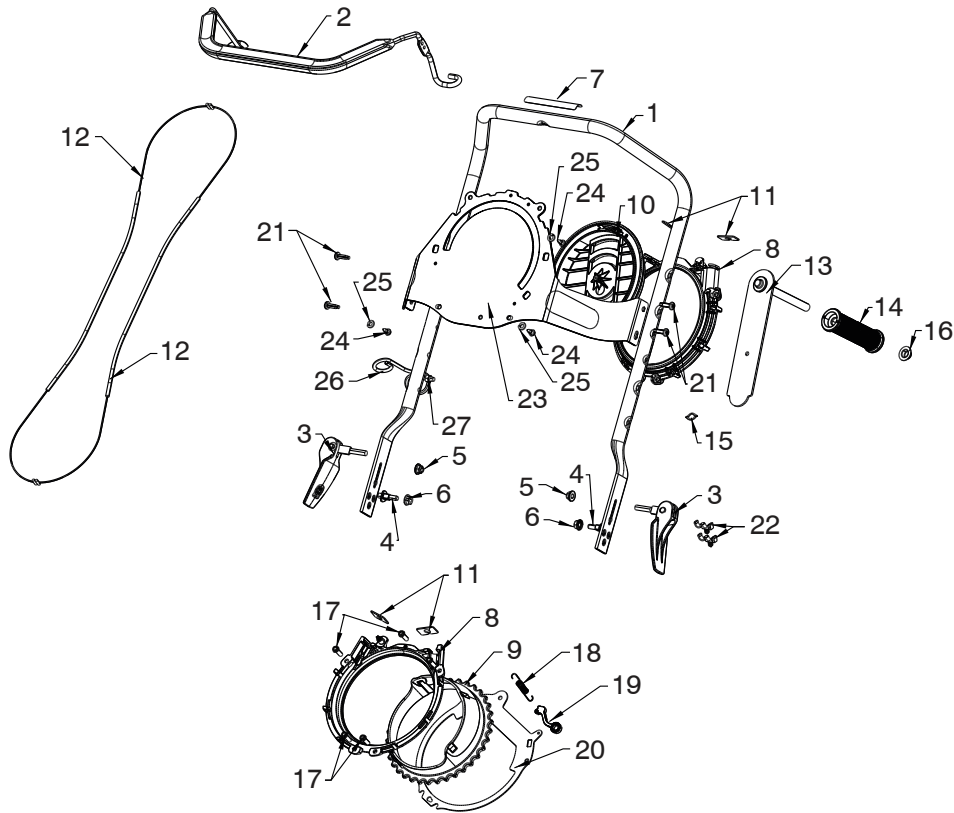

06.07.005-A

KEY NO.	PART NO.	DESCRIPTION	KEY NO.	PART NO.	DESCRIPTION
1	532 44 34-32	UPPER HANDLE ERGO GRAY	16	532 43 54-17	NUT PUSH AXLE .05"
2	532 44 34-33	OVERMOLD BAIL ASM HUSQ	17	817 41 13-12	SCREW HEX WSHHD #13 X .750
3	532 44 30-21	QUICK ADJUST SUBASM	18	580 66 45-01	CHUTE CONTROL SPRING ROTATE
4	532 19 92-55	STUD QUICK ADJ	19	532 43 48-78	CHUTE RATCHET ARM
5	532 44 22-48	NUT 5/16-18 FLANGE NYLOCK BLACK	20	580 85 56-01	CHUTE BASE PLATE
6	873 97 05-00	NUT LOCK HEX FLANGE	21	532 44 22-50	SCREW PAN HD TORX 1/4-20 X .750
7	532 43 75-06	DECAL HANDLE BAR AUGER INSTRUCTIONAL	22	532 14 50-06	CABLE GUIDE
8	532 44 39-38	CHUTE RETAINER RING	23	580 85 59-01	SUPPORT BRACKET DDC STAMP
9	532 44 39-39	CHUTE BASE DCC BLACK	24	532 18 44-71	SCREW SHOULDER 10/24 X .62
10	532 44 39-40	PULLEY DCC RING BLACK	25	810 04 04-00	LOCKWASHER 1/4 SPLIT
11	532 43 68-06	BRACKET CABLE DCC	26	532 44 22-34	ROPE GUIDE
12	532 43 68-05	CABLE DCC	27	532 13 20-04	NUT HEX 1/4-20 BZO
13	532 43 68-90	HANDLE SUDASM PIVOT			
14	532 44 28-35	HANDLE GRIP SUBASM			
15	532 44 47-49	WASHER THREE WAVE SPRING			

NOTE: All component dimensions given in U.S. inches. 1 inch = 25.4 mm
IMPORTANT: Use only Original Equipment Manufacturer (O.E.M.) replacement parts. Failure to do so could be hazardous, damage your snow thrower and void your warranty.

REPAIR PARTS SNOW THROWER - - MODEL NUMBER ST 121E (96183000101)

DRIVE ASSEMBLY

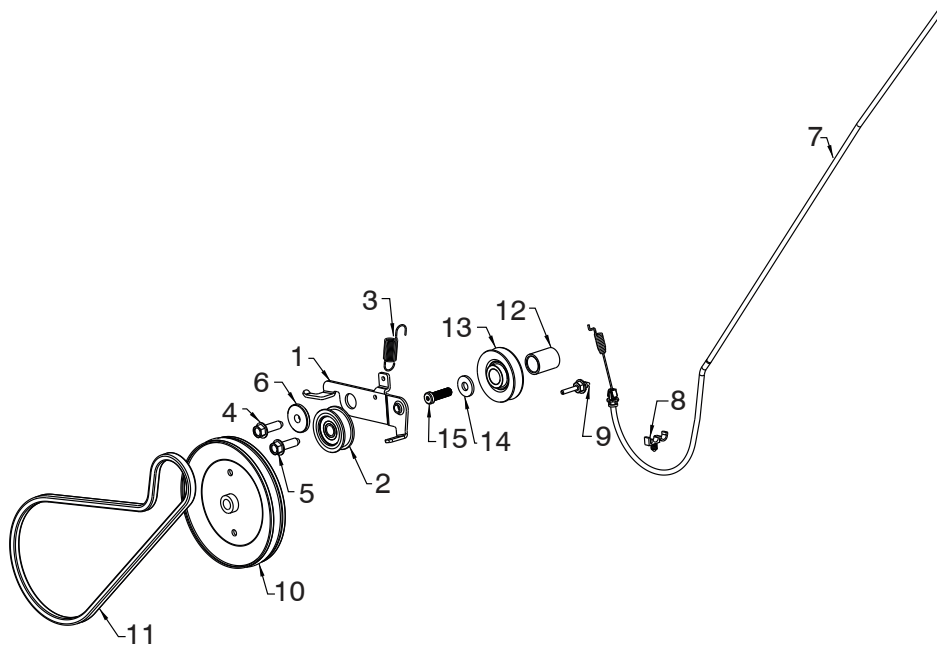

06.01.001-B

KEY NO.	PART NO.	DESCRIPTION
1	580 85 53-01	IDLER ARM
2	532 16 60-43	IDLER PULLEY
3	532 43 48-59	RETURN SPRING
4	817 06 06-20	SCREW 3/8-16 X 1-1/4 (TORQUE 13-18 FT-LBS)
5	817 06 06-20	SCREW 3/8-16 X 1-1/4 (TORQUE 22-27 FT-LBS)
6	532 19 90-92	SPACER
7	532 44 30-18	CLUTCH CABLE ASM
8	532 14 50-06	PUSH CLIP
9	532 43 45-02	BELT KEEPER
10	532 43 53-83	DRIVE PULLEY
11	532 43 72-61	BELT
12	532 43 48-60	ENGINE CRANK SPACER
13	532 42 64-90	ENGINE PULLEY
14	532 85 10-74	WASHER
15	532 43 08-17	SCREW 3/8-24 X 1/25

NOTE: All component dimensions given in U.S. inches. 1 inch = 25.4 mm
IMPORTANT: Use only Original Equipment Manufacturer (O.E.M.) replacement parts. Failure to do so could be hazardous, damage your snow thrower and void your warranty.

REPAIR PARTS SNOW THROWER - - MODEL NUMBER ST 121E (96183000101) ENGINE ASSEMBLY

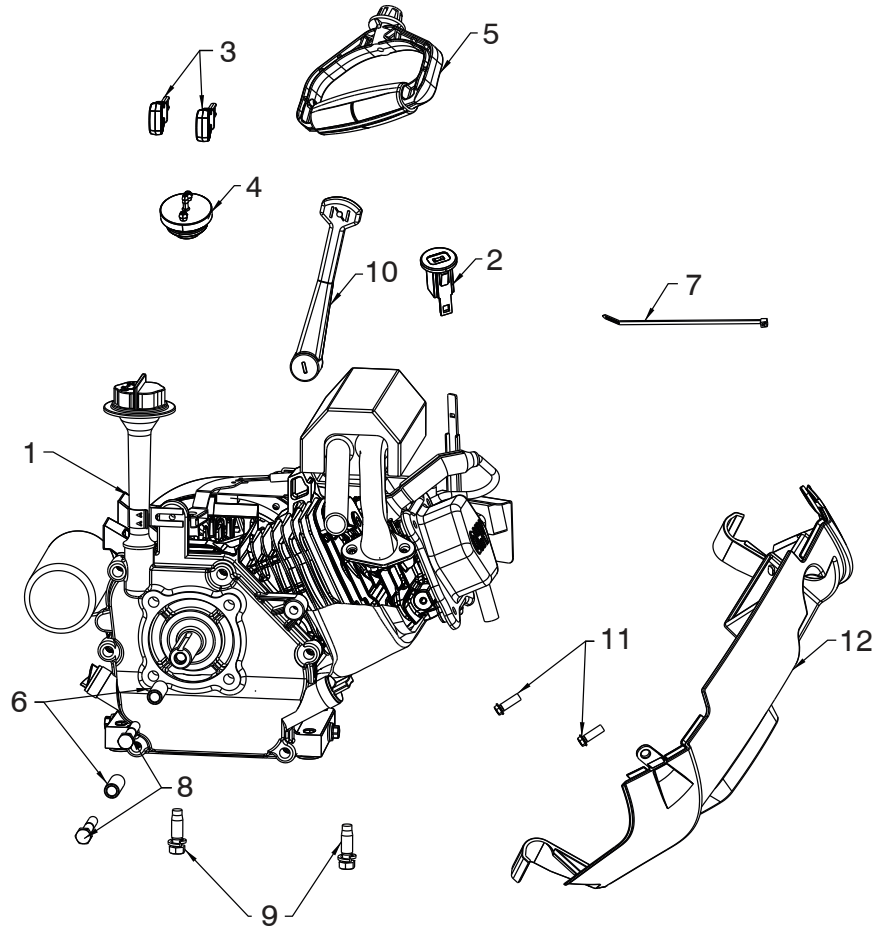

06.02.007-A

KEY NO.	PART NO.	DESCRIPTION
1	532 44 21-59	ENGINE LCT 208CC ESTART W/ALT
2	532 43 54-07	HOUSING KEY
3	532 44 39-35	KEY SET (QTY: 2)
4	532 43 62-35	PRIMER BULB
5	532 44 30-70	HANDLE STARTER
6	532 43 48-57	SPACER ENGINE
7	532 44 46-49	CABLE TIE
8	532 43 55-78	SCREW 5/16-24 X 2.00 HHCS
9	532 15 04-06	BOLT ENGINE 3/8-16 DOGPOINT
10	532 43 48-74	LEVER CHOKE
11	817 41 13-12	SCREW HEX WSHHD #13 X .750
12	532 44 34-24	COVER REAR LOWER HUSQ

NOTE: All component dimensions given in U.S. inches. 1 inch = 25.4 mm
IMPORTANT: Use only Original Equipment Manufacturer (O.E.M.) replacement parts.
 Failure to do so could be hazardous, damage your snow thrower and void your warranty.

REPAIR PARTS SNOW THROWER - - MODEL NUMBER ST 121E (96183000101)

FRAME ASSEMBLY

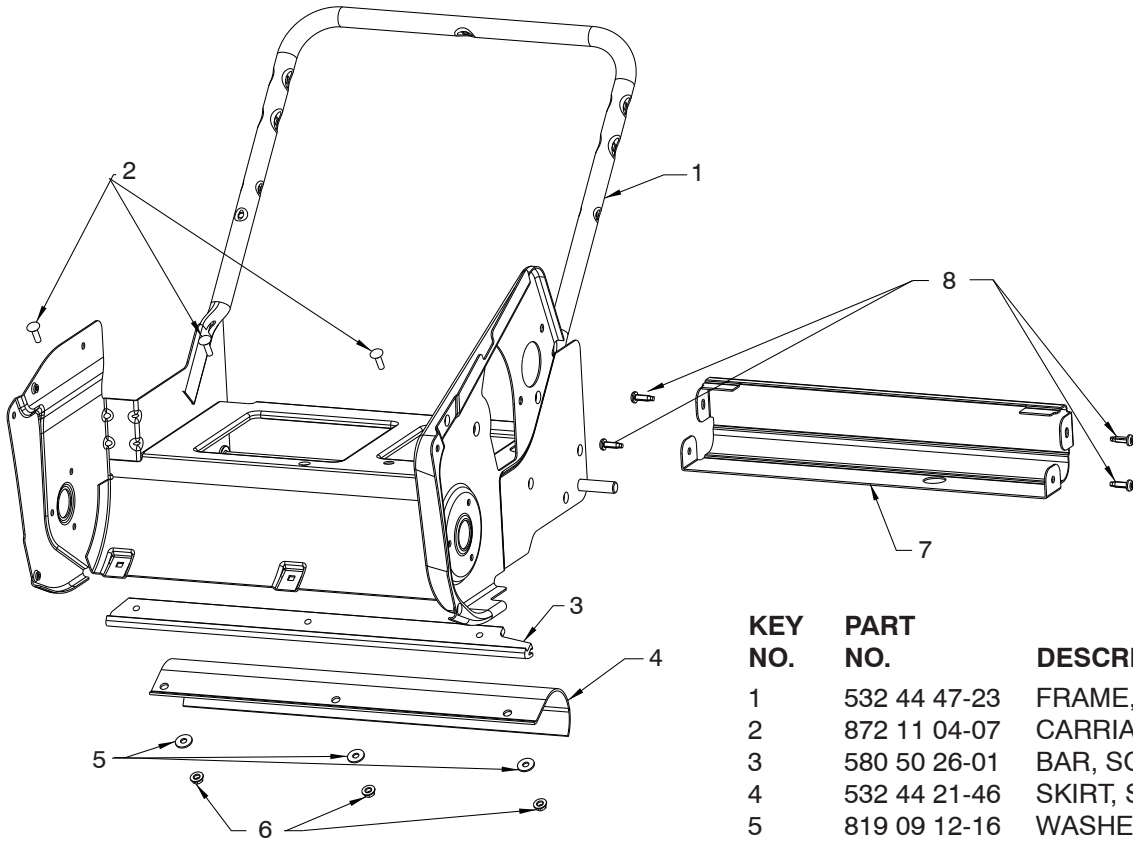

06.00.002-A

KEY NO.	PART NO.	DESCRIPTION
1	532 44 47-23	FRAME, WELDMENT
2	872 11 04-07	CARRIAGE BOLT 1/4-20 X 7/8
3	580 50 26-01	BAR, SCRAPER UHMW
4	532 44 21-46	SKIRT, SCRAPER SSST
5	819 09 12-16	WASHER 9/32 X 3/4 X 16 GA
6	532 19 17-30	NUT, HEX FLANGE 1/4-20 CTR LOCK
7	532 44 34-23	SUPPORT, SSST REAR FRAME
8	532 44 22-50	SCREW, PAN HD TORX 1/4-20 X .750

NOTE: All component dimensions given in U.S. inches. 1 inch = 25.4 mm
IMPORTANT: Use only Original Equipment Manufacturer (O.E.M.) replacement parts. Failure to do so could be hazardous, damage your snow thrower and void your warranty.

**REPAIR PARTS SNOW THROWER - - MODEL NUMBER ST 121E (96183000101)
 FRAME ASSEMBLY**

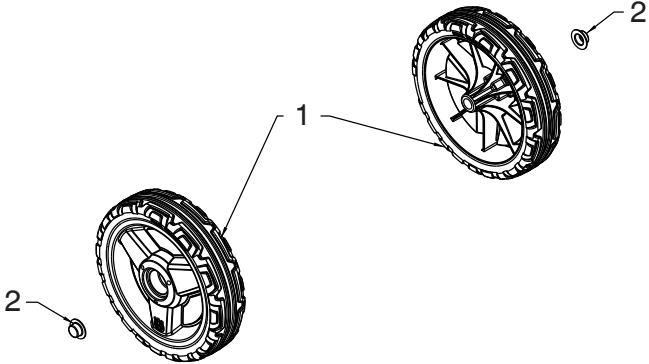

06.06.007-A

KEY NO.	PART NO.	DESCRIPTION
1	532 44 28-25	WHEEL HUSQVARNA 8"
2	532 43 54-17	PUSH NUT

NOTE: All component dimensions given in U.S. inches. 1 inch = 25.4 mm
IMPORTANT: Use only Original Equipment Manufacturer (O.E.M.) replacement parts.
 Failure to do so could be hazardous, damage your snow thrower and void your warranty.

REPAIR PARTS SNOW THROWER - - MODEL NUMBER ST 121E (96183000101)

SHROUD ASSEMBLY

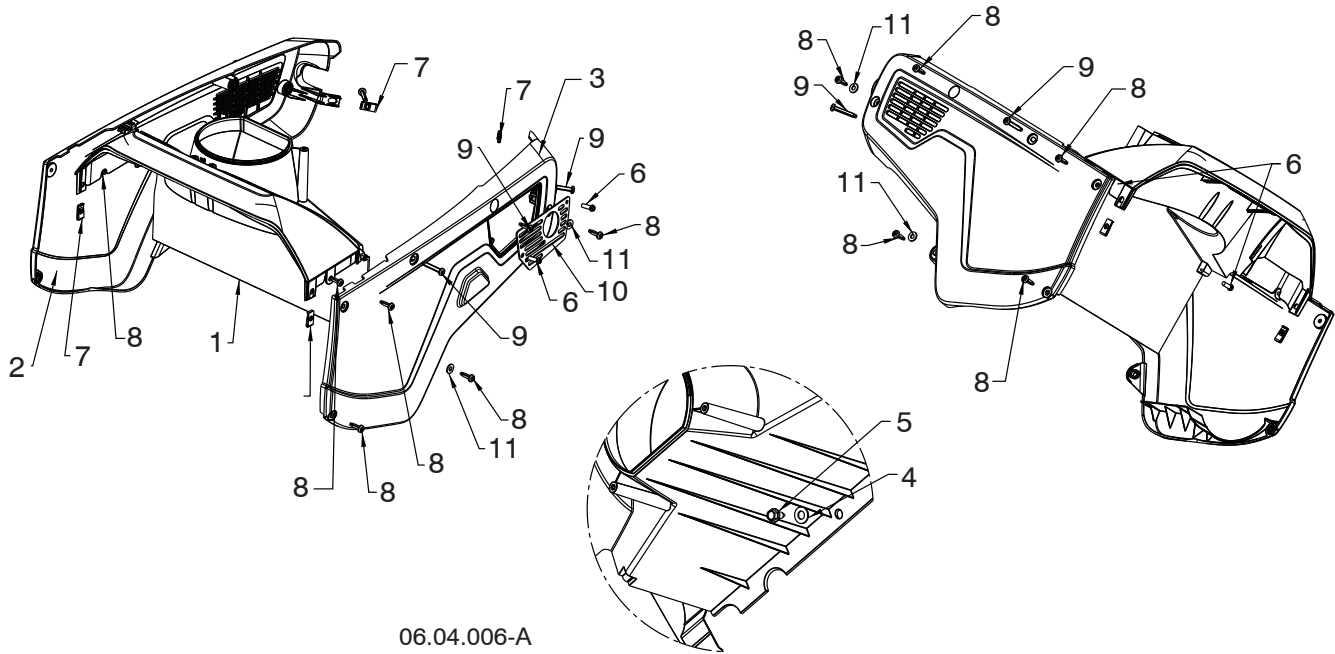

06.04.006-A

KEY NO.	PART NO.	DESCRIPTION
1	532 44 34-25	PLENUM
2	532 44 34-26	NON – DRIVE COVER
3	532 44 39-73	DRIVE COVER SIDE
4	819 13 13-16	WASHER 13/32 X 13/16 16 GA
5	532 42 88-67	BOLT 5/16-18 X .75
6	817 41 13-12	BOLT 13-16 X .75
7	532 19 66-88	THREADED CLIP
8	532 44 22-50	SCREW 1/4-20 X .75
9	532 44 42-62	SCREW 1/4-20 X 1.5
10	580 83 35-01	EXHAUST PLATE
11	819 09 10-16	WASHER FLAT 1/4 SAE

NOTE: All component dimensions given in U.S. inches. 1 inch = 25.4 mm
IMPORTANT: Use only Original Equipment Manufacturer (O.E.M.) replacement parts. Failure to do so could be hazardous, damage your snow thrower and void your warranty.

REPAIR PARTS SNOW THROWER - - MODEL NUMBER ST 121E (96183000101)

SHROUD ASSEMBLY

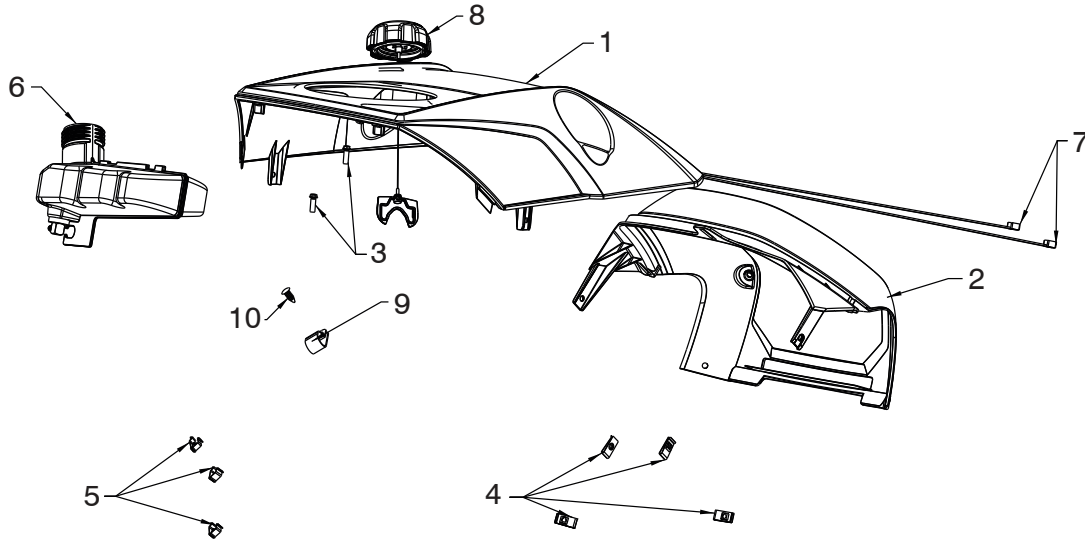

06.04.015-C

KEY NO.	PART NO.	DESCRIPTION
1	532 43 88-44	TOP COVER
2	532 44 34-29	REAR UPPER COVER
3	817 41 13-12	BOLT 13-16 X .75
4	532 19 66-88	THREADED CLIP
5	532 43 48-68	TRIM CLIP
6	580 98 26-01	FUEL TANK ASSEMBLY
7	532 14 68-48	CABLE TIE
8	584 07 55-01	FUEL CAP/GASKET
9	532 19 79-91	P-CLIP
10	532 42 81-24	CHRISTMAS TREE CLIP

NOTE: All component dimensions given in U.S. inches. 1 inch = 25.4 mm
IMPORTANT: Use only Original Equipment Manufacturer (O.E.M.) replacement parts. Failure to do so could be hazardous, damage your snow thrower and void your warranty.

REPAIR PARTS SNOW THROWER -- MODEL NUMBER ST 121E (96183000101)
ENGINE, LCT **COMPLETE ENGINE-442159**

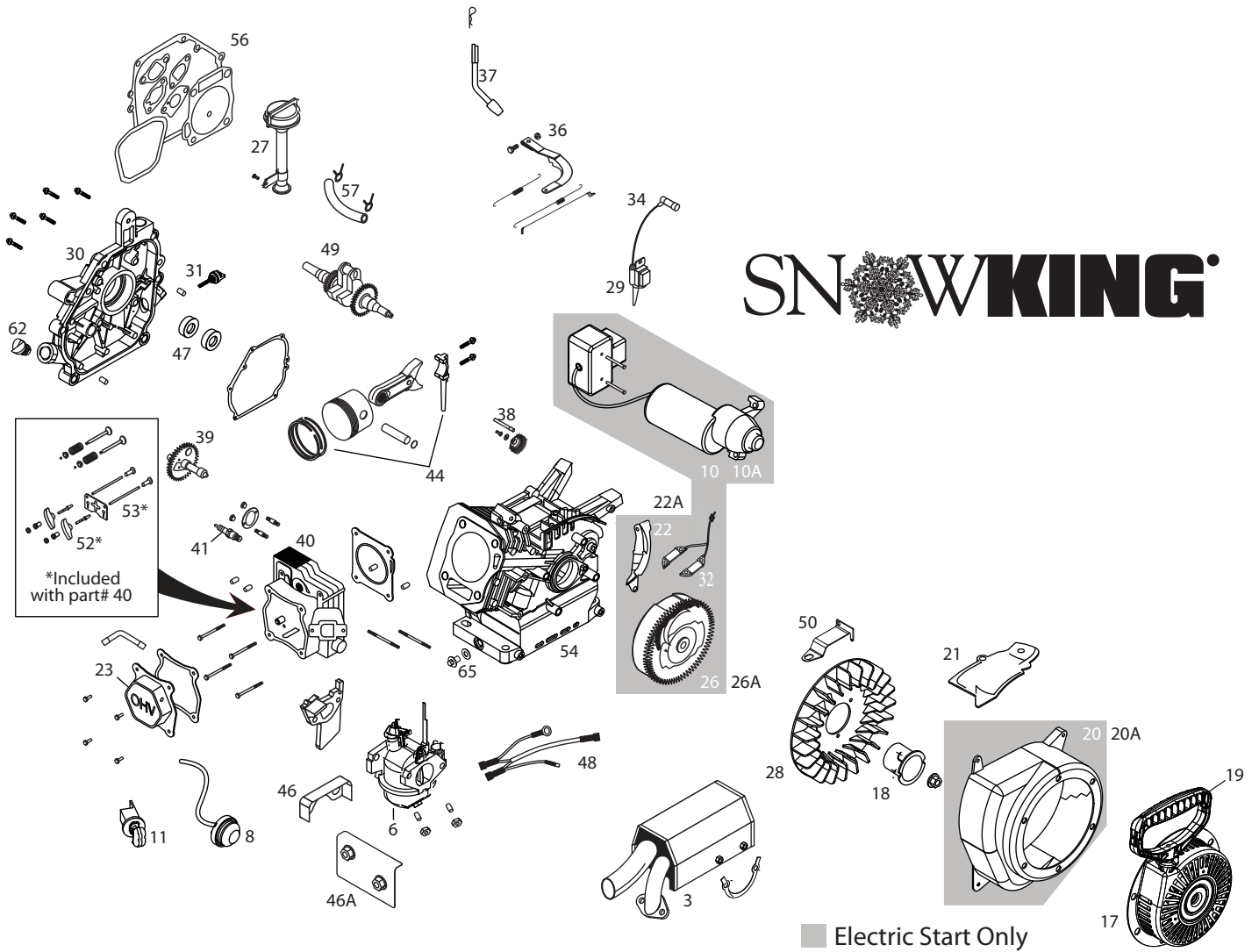

NOTE: All component dimensions given in U.S. inches. 1 inch = 25.4 mm
IMPORTANT: Use only Original Equipment Manufacturer (O.E.M.) replacement parts.
 Failure to do so could be hazardous, damage your snow thrower and void your warranty.

REPAIR PARTS SNOW THROWER -- MODEL NUMBER ST 121E (96183000101)
ENGINE, LCT **COMPLETE ENGINE-442159**

KEY NO.	PART NO.	DESCRIPTION
3	532 43 79-89	Muffler Assembly-Snow
6	532 43 79-90	Snow Carburetor Assy
8	532 43 71-23	Fuel Primer Bulb With Hose
10	532 43 71-24	Electric Starter Assy
10A	532 43 71-25	European 230V Electricstarter
11	532 42 49-54	Key Switch Assy
12	532 42 49-55	CDI Box
17	532 43 69-67	Recoil Starter Assembly-Snow
18	532 43 79-91	Starter Cup Small
19	532 42 49-68	Snow Starter Grip (Deluxe)
20	532 43 79-92	Blower Housing Assembly Electric Start - Snow (Black)
20A	532 43 79-93	Blower Housing Assembly Manual Start - Snow (Black)
21	532 43 79-94	Shield, Cylinder
22	532 43 79-95	Shield, Flywheel Electric Start (If Equipped)
22A	532 43 95-96	Shield, Flywheel Manual Start
23	532 43 79-97	Valve Cover
26	532 43 79-98	Electric Start Flywheel Assy
26A	532 43 79-99	Manual Start Flywheel Assy
27	532 43 80-00	High Oil Fill Tube Assy
28	532 43 80-01	Flywheel Fan
29	532 42 05-95	Ignition Coil Assy (Hi-Temp)
29A	532 44 39-34	Ignition Coil (CDI) (used on engines without ref. 12)
30	532 43 80-02	Crankcase Cover Assy
31	532 42 09-61	Black Oil Dipstick
32	532 44 40-90	Charging Coil (18 Watt)
34	532 43 69-66	Spark Plug Boot
36	532 43 80-03	Governor Arm Assy
37	532 43 80-04	Governor Shaft
38	532 42 96-46	Governor Gear Assy
39	532 43 80-05	Camshaft
40	532 43 80-06	Cylinder Head Assy
41	532 42 49-39	Spark Plug
44	532 43 80-07	Piston And Rod Assy
46	532 42 92-60	Vapor Shield
47	532 43 80-08	Seal Kit
48	532 43 79-67	Wire Harness
49	532 43 80-09	Crankshaft
50	532 42 92-59	Speed Control Bracket
52	532 43 80-10	Rocker Arm Kit
53	532 43 80-11	Push Rod Kit
54	532 43 80-12	Cylinder Assembly
56	532 43 80-13	Gasket Kit
57	532 43 80-14	Fuel Hose Kit
62	532 42 95-98	Non-Removable Oil Plug
65	532 43 54-95	Oil Drain Plug Kit

NOTE: All component dimensions given in U.S. inches. 1 inch = 25.4 mm
IMPORTANT: Use only Original Equipment Manufacturer (O.E.M.) replacement parts.
 Failure to do so could be hazardous, damage your snow thrower and void your warranty.

