

OWNER'S MANUAL 2022



TE 150i

Art. no. 3402537en



DEAR HUSQVARNA MOTORCYCLES CUSTOMER

Congratulations on your decision to purchase a Husqvarna motorcycle. You are now the owner of a state-of-the-art sports vehicle which, with appropriate care, will bring you pleasure for a long time to come.

We wish you good and safe riding at all times!

Enter the serial numbers of your vehicle below.

Vehicle identification number (📖 p. 15)	Dealer's stamp
Engine number (📖 p. 15)	
Key number (TE 150i EU) (📖 p. 15)	

The Owner's Manual contained the latest information for this model series at the time of publication. However, minor differences due to further developments in design cannot be ruled out completely.

All specifications contained herein are non-binding. Husqvarna Motorcycles GmbH specifically reserves the right to modify or delete technical specifications, prices, colors, forms, materials, services, designs, equipment, etc., without prior notice and without specifying reasons, to adapt these to local conditions, as well as to stop production of a particular model without prior notice. Husqvarna Motorcycles accepts no liability for delivery options, deviations from illustrations and descriptions, as well as misprints and other errors. The models portrayed partly contain special equipment that does not belong to the regular scope of supply.

© 2021 Husqvarna Motorcycles GmbH, Mattighofen Austria

All rights reserved

Reprinting, including excerpts, and duplication of any kind only with the written consent of the publisher.



ISO 9001(12 100 6061)

Husqvarna Motorcycles applies quality assurance processes that lead to the highest possible product quality as defined in the ISO 9001 international quality management standard.

Issued by: TÜV-Management Service

REG.NO. 12 100 6061

Husqvarna Motorcycles GmbH
Stallhofnerstraße 3
5230 Mattighofen, Austria

This document is valid for the following models:

TE 150i EU (F2103V9)

TE 150i US (F2175V9)



3402537en

11/2021

TABLE OF CONTENTS

1	MEANS OF REPRESENTATION.....	6	6.11	Start button (TE 150i EU)	19
1.1	Symbols used	6	6.12	Start button (TE 150i US)	19
1.2	Formats used	6	6.13	Map switch	20
2	SAFETY ADVICE	7	6.14	Overview of indicator lamps (TE 150i EU)	20
2.1	Use definition – intended use	7	6.15	Overview of indicator lamps (TE 150i US)	20
2.2	Misuse.....	7	6.16	Opening fuel tank filler cap	21
2.3	Safety advice	7	6.17	Closing the fuel tank filler cap.....	21
2.4	Degrees of risk and symbols	8	6.18	Opening 2-stroke oil tank cap	22
2.5	Tampering warning	8	6.19	Closing 2-stroke oil tank cap	22
2.6	Safe operation.....	8	6.20	Cold start button.....	22
2.7	Protective clothing	9	6.21	Idle speed adjusting screw	23
2.8	Work rules.....	9	6.22	Shift lever	23
2.9	Environment.....	10	6.23	Kick starter lever	24
2.10	Owner's Manual.....	10	6.24	Foot brake lever	24
3	IMPORTANT NOTES	11	6.25	Side stand	24
3.1	Manufacturer warranty, implied warranty	11	6.26	Steering lock (TE 150i EU)	25
3.2	Fuel, auxiliary substances.....	11	6.27	Locking the steering (TE 150i EU).....	25
3.3	Spare parts, Husqvarna Motorcycles technical accessories	11	6.28	Unlocking the steering (TE 150i EU) ...	25
3.4	Service	11	7	COMBINATION INSTRUMENT	26
3.5	Figures	11	7.1	Overview	26
3.6	Customer service.....	12	7.2	Activation	26
4	VIEW OF VEHICLE	13	7.3	Messages on the combination instrument	26
4.1	View of vehicle, front left (example)	13	7.4	Adjusting the combination instrument	26
4.2	View of vehicle, rear right (example).....	14	7.5	Setting the kilometers or miles	27
5	SERIAL NUMBERS.....	15	7.6	Setting the clock	28
5.1	Vehicle identification number.....	15	7.7	Setting the service display.....	28
5.2	Type label (TE 150i EU).....	15	7.8	Speed, time, and DST distance 1	29
5.3	Key number (TE 150i EU).....	15	7.9	Speed, time, and DST2 distance 2	29
5.4	Engine number.....	15	7.10	AVG average speed, ART operating hours, and ODO total distance covered	30
5.5	Fork article number.....	16	8	PREPARING FOR USE.....	31
5.6	Shock absorber article number	16	8.1	Advice on preparing for first use.....	31
6	CONTROLS	17	8.2	Running in the engine	32
6.1	Clutch lever	17	8.3	Starting power of lithium-ion batteries at low temperatures	33
6.2	Hand brake lever.....	17	8.4	Preparing the vehicle for difficult operating conditions	33
6.3	Throttle grip.....	17	8.5	Preparing the vehicle for rides on dry sand	33
6.4	Stop button (TE 150i EU)	17	8.6	Preparing the vehicle for rides on wet sand	35
6.5	Stop button (TE 150i US)	18	8.7	Preparing the vehicle for rides on wet and muddy circuits	36
6.6	Horn button (TE 150i EU)	18	8.8	Preparing vehicle for high temperatures or slow riding	36
6.7	Light switch (TE 150i EU).....	18			
6.8	Light switch (TE 150i US).....	18			
6.9	Turn signal switch (TE 150i EU)	19			
6.10	Emergency OFF switch (TE 150i EU)	19			



















8.9	Preparing the vehicle for low temperatures or snow.....	37	12	SERVICE WORK ON THE CHASSIS.....	56
9	RIDING INSTRUCTIONS.....	38	12.1	Raising the motorcycle with a lift stand.....	56
9.1	Checks and maintenance measures when preparing for use.....	38	12.2	Removing the motorcycle from the lift stand.....	56
9.2	Starting the vehicle.....	38	12.3	Bleeding the fork legs.....	56
9.3	Starting off.....	39	12.4	Cleaning the dust boots of the fork legs.....	57
9.4	Shifting, riding.....	39	12.5	Removing the fork legs 	57
9.5	Braking.....	40	12.6	Installing the fork legs 	58
9.6	Stopping, parking.....	41	12.7	Removing the fork protector.....	59
9.7	Transporting.....	41	12.8	Installing the fork protector.....	59
9.8	Refueling.....	42	12.9	Removing the lower triple clamp 	59
9.9	Adding 2-stroke oil.....	43	12.10	Installing the lower triple clamp 	60
10	SERVICE SCHEDULE.....	44	12.11	Checking the steering head bearing play.....	62
10.1	Additional information.....	44	12.12	Adjusting steering head bearing play 	63
10.2	Required work.....	44	12.13	Lubricating the steering head bearing 	63
10.3	Recommended work.....	45	12.14	Removing front fender.....	63
11	TUNING THE CHASSIS.....	47	12.15	Installing front fender.....	64
11.1	Checking the basic chassis setting with rider's weight.....	47	12.16	Removing the shock absorber 	65
11.2	Compression damping of the shock absorber.....	47	12.17	Installing the shock absorber 	66
11.3	Adjusting the low-speed compression damping of the shock absorber.....	47	12.18	Removing the seat.....	68
11.4	Adjusting the high-speed compression damping of the shock absorber.....	48	12.19	Mounting the seat.....	68
11.5	Adjusting the rebound damping of the shock absorber.....	49	12.20	Removing the air filter box cover.....	69
11.6	Measuring the dimension of the rear wheel unloaded.....	49	12.21	Installing the air filter box cover.....	69
11.7	Checking the static sag of the shock absorber.....	50	12.22	Removing the air filter 	70
11.8	Checking the riding sag of the shock absorber.....	50	12.23	Cleaning the air filter and air filter box 	70
11.9	Adjusting the spring preload of the shock absorber 	51	12.24	Installing the air filter 	71
11.10	Adjusting the riding sag 	52	12.25	Removing the main silencer.....	71
11.11	Checking the basic setting of the fork.....	52	12.26	Installing the main silencer.....	72
11.12	Adjusting the compression damping of the fork.....	53	12.27	Changing the glass fiber yarn filling of the main silencer 	72
11.13	Adjusting the rebound damping of the fork.....	53	12.28	Removing the right side cover.....	73
11.14	Adjusting the spring preload of the fork.....	54	12.29	Installing the right side cover.....	73
11.15	Handlebar position.....	54	12.30	Removing the fuel tank 	74
11.16	Adjusting the handlebar position 	55	12.31	Installing the fuel tank 	75
			12.32	Checking the chain for dirt.....	77
			12.33	Cleaning the chain.....	77
			12.34	Checking the chain tension.....	78
			12.35	Adjusting the chain tension.....	78
			12.36	Checking the chain, rear sprocket, engine sprocket, and chain guide.....	79
			12.37	Checking the frame 	82
			12.38	Checking the link fork 	82
			12.39	Checking the throttle cable routing....	82
			12.40	Checking the rubber grip.....	83
			12.41	Adjusting the basic position of the clutch lever.....	83

TABLE OF CONTENTS

12.42	Checking/correcting the fluid level of the hydraulic clutch	84	15.13	Diagnostics connector	117
12.43	Changing the hydraulic clutch fluid 🛠️	85	16	COOLING SYSTEM	118
12.44	Removing the engine guard	86	16.1	Cooling system	118
12.45	Installing the engine guard	86	16.2	Checking the antifreeze and coolant level	118
13	BRAKE SYSTEM	87	16.3	Checking the coolant level	119
13.1	Adjusting the basic position of the hand brake lever	87	16.4	Draining the coolant 🛠️	119
13.2	Checking the brake discs	87	16.5	Refilling with coolant 🛠️	120
13.3	Checking the front brake fluid level	88	16.6	Changing the coolant 🛠️	122
13.4	Adding front brake fluid 🛠️	88	17	TUNING THE ENGINE	124
13.5	Checking the front brake linings	89	17.1	Checking the play in the throttle cable	124
13.6	Changing the brake linings of the front brake 🛠️	90	17.2	Adjusting the play in the throttle cable 🛠️	124
13.7	Checking the free travel of the foot brake lever	92	17.3	Setting the characteristic map of the throttle response 🛠️	125
13.8	Adjusting the basic position of the foot brake lever 🛠️	93	17.4	Adjusting the idle speed 🛠️	126
13.9	Checking the rear brake fluid level	94	17.5	Programming ambient air pressure	127
13.10	Adding rear brake fluid 🛠️	94	17.6	Checking the basic position of the shift lever	127
13.11	Checking the brake linings of the rear brake	95	17.7	Adjusting the basic position of the shift lever 🛠️	128
13.12	Changing the rear brake linings 🛠️	96	18	SERVICE WORK ON THE ENGINE	129
14	WHEELS, TIRES	98	18.1	Changing the fuel screen 🛠️	129
14.1	Removing the front wheel 🛠️	98	18.2	Checking 2-stroke oil level	130
14.2	Installing the front wheel 🛠️	99	18.3	Priming oil pump 🛠️	130
14.3	Removing the rear wheel 🛠️	99	18.4	Cleaning the oil screen in the oil tank 🛠️	132
14.4	Installing the rear wheel 🛠️	100	18.5	Checking the gear oil level	135
14.5	Checking the tire condition	102	18.6	Changing the gear oil 🛠️	135
14.6	Checking tire pressure	102	18.7	Adding the gear oil 🛠️	136
14.7	Checking spoke tension	103	19	CLEANING, CARE	138
15	ELECTRICAL SYSTEM	104	19.1	Cleaning the motorcycle	138
15.1	Removing the 12-V battery 🛠️	104	19.2	Checks and maintenance steps for winter operation	139
15.2	Installing the 12-V battery 🛠️	106	20	STORAGE	140
15.3	Charging the 12-V battery 🛠️	107	20.1	Storage	140
15.4	Changing main fuse	109	20.2	Preparing for use after storage	141
15.5	Changing the fuses of individual electrical power consumers	110	21	TROUBLESHOOTING	142
15.6	Removing the headlight mask with the headlight	112	22	BLINK CODE	145
15.7	Installing the headlight mask with the headlight	112	23	TECHNICAL DATA	147
15.8	Changing the headlight bulb	114	23.1	Engine	147
15.9	Changing the turn signal bulb (TE 150i EU)	114	23.2	Engine tightening torques	147
15.10	Checking the headlight setting	115	23.3	Capacities	149
15.11	Adjusting the headlight range	116	23.3.1	Gear oil	149
15.12	Changing the combination instrument battery	116			

23.3.2	Coolant.....	149
23.3.3	Fuel.....	149
23.4	Chassis	149
23.5	Electrical system.....	150
23.6	Tires	150
23.7	Fork.....	150
23.8	Shock absorber	151
23.9	Chassis tightening torques	152
24	SUBSTANCES.....	155
25	AUXILIARY SUBSTANCES.....	157
26	STANDARDS	159
27	INDEX OF SPECIAL TERMS	160
28	LIST OF ABBREVIATIONS	161
29	LIST OF SYMBOLS	162
29.1	Red symbols	162
29.2	Yellow and orange symbols.....	162
29.3	Green and blue symbols.....	162
	INDEX.....	163

1 MEANS OF REPRESENTATION

1.1 Symbols used

The meaning of specific symbols is described below.



Indicates an expected reaction (e.g., of a work step or a function).



Indicates an unexpected reaction (e.g., of a work step or a function).



Indicates work that requires expert knowledge and technical understanding. In the interest of your own safety, have this work performed by an authorized Husqvarna Motorcycles workshop. Your motorcycle will be cared for there to the highest degree by specially trained experts using the special tools required.



Indicates a page reference (more information is provided on the specified page).



Indicates information with more details or tips.



Indicates the result of a testing step.



Indicates the end of an activity, including potential reworking.

1.2 Formats used

The typographical formats used in this document are explained below.

Proprietary name	Indicates a proprietary name.
Name[®]	Indicates a protected name.
Brand[™]	Indicates a brand available on the open market.
<u>Underlined terms</u>	Refer to technical details of the vehicle or indicate technical terms, which are explained in the glossary.

2.1 Use definition – intended use

(TE 150i EU)

This vehicle has been designed and built to withstand the normal stresses and strains of racing. This vehicle complies with the currently valid regulations and categories of the top international motorsports organizations.



Info

This vehicle is only authorized for operation on public roads in the homologated (restricted) version. The derestricted version of this vehicle must only be operated in closed off areas away from public highway traffic.

This vehicle is designed for use in offroad endurance competition, and not primarily for use in motocross.

(TE 150i US)

This vehicle has been designed and built to withstand the normal stresses and strains of racing. This vehicle complies with the currently valid regulations and categories of the top international motorsports organizations.



Info

Only operate this vehicle in closed-off areas remote from public road traffic.

This vehicle is designed for use in offroad endurance competition, and not primarily for use in motocross.

2.2 Misuse

The vehicle must only be used as intended.

Dangers can arise for people, property and the environment through use not as intended.

Any use of the vehicle beyond the intended and defined use constitutes misuse.

Misuse also includes the use of operating and auxiliary fluids which do not meet the required specification for the respective use.

2.3 Safety advice

A number of safety instructions need to be followed to operate the product described safely. Therefore read this instruction and all further instructions included carefully. The safety instructions are highlighted in the text and are referred to at the relevant passages.



Info

Various information and warning labels are attached in prominent locations on the product described.

Do not remove any information or warning labels. If they are missing, you or others may not recognize dangers and may therefore be injured.

2.4 Degrees of risk and symbols



Danger

Identifies a danger that will immediately and invariably lead to fatal or serious permanent injury if the appropriate measures are not taken.



Warning

Identifies a danger that is likely to lead to fatal or serious injury if the appropriate measures are not taken.



Caution

Identifies a danger that may lead to minor injuries if the appropriate measures are not taken.

Note

Identifies a danger that will lead to considerable machine and material damage if the appropriate measures are not taken.



Note

Indicates a danger that will lead to environmental damage if the appropriate measures are not taken.

2.5 Tampering warning

Tampering with the noise control system is prohibited. Federal law prohibits the following acts or the causing thereof:

- 1 The removal or rendering inoperative by any person other than for purposes of servicing, repair, or replacement, of any device or element of design incorporated into any new vehicle for the purpose of noise control prior to its sale or delivery to the ultimate purchaser or while it is in use, or
- 2 the use of the vehicle after such device or element of design has been removed or rendered inoperative by any person.

Among those acts presumed to constitute tampering are the acts listed below:

- 1 Removal or puncturing of the main silencers, baffles, header pipes or any other components which conduct exhaust gases.
- 2 Removal or puncturing of parts of the intake system.
- 3 Lack of proper maintenance.
- 4 Replacing moving parts of the vehicle, or parts of the exhaust system or intake system, with parts other than those specified by the manufacturer.

2.6 Safe operation



Danger

Danger of accidents A rider who is not fit to ride poses a danger to him or herself and others.

- Do not operate the vehicle if you are not fit to ride due to alcohol, drugs or medication.
- Do not operate the vehicle if you are physically or mentally impaired.



Danger

Danger of poisoning Exhaust gases are toxic and inhaling them may result in unconsciousness and death.

- Always make sure there is sufficient ventilation when running the engine.
- Use effective exhaust extraction when starting or running the engine in an enclosed space.

**Warning****Danger of burns** Some vehicle components become very hot when the vehicle is operated.

- Do not touch any parts such as the exhaust system, radiator, engine, shock absorber, or brake system before the vehicle parts have cooled down.
- Let the vehicle parts cool down before you perform any work on the vehicle.

Only operate the vehicle when it is in perfect technical condition, in accordance with its intended use, and in a safe and environmentally compatible manner.

The vehicle should only be used by trained persons. An appropriate driver's license is needed to drive the vehicle on public roads.

Have malfunctions that impair safety promptly eliminated by an authorized Husqvarna Motorcycles workshop. Adhere to the information and warning labels on the vehicle.

2.7 Protective clothing**Warning****Risk of injury** Missing or poor protective clothing presents an increased safety risk.

- Wear appropriate protective clothing such as helmet, boots, gloves as well as trousers and a jacket with protectors on all rides.
- Always wear protective clothing that is in good condition and meets the legal regulations.

In the interest of your own safety, Husqvarna Motorcycles recommends that you only operate the vehicle while wearing protective clothing.

2.8 Work rules

Unless specified otherwise, the ignition must be turned off during all work (models with ignition lock, models with remote key) or the engine must be at a standstill (models without ignition lock or remote key).

Special tools are necessary for certain tasks. The tools are not a component of the vehicle, but can be ordered using the number in parentheses. Example: bearing puller (15112017000)

Unless otherwise noted, normal conditions apply to all tasks and descriptions.

Ambient temperature	20 °C (68 °F)
Ambient air pressure	1,013 mbar (14.69 psi)
Relative air humidity	60 ± 5 %

During assembly, use new parts to replace parts which cannot be reused (e.g. self-locking screws and nuts, expansion screws, seals, sealing rings, O-rings, pins, and lock washers).

In the case of certain screws, a screw adhesive (e.g. **Loctite**[®]) is required. Observe the manufacturer's instructions.

If thread locker (e.g., **Precote**[®]) has already been applied to a new part, do not apply any additional thread locker.

After disassembly, clean the parts that are to be reused and check them for damage and wear. Change damaged or worn parts.

After completing a repair or service work, check the operating safety of the vehicle.

2.9 Environment

If you use your motorcycle responsibly, you can ensure that problems and conflicts do not occur. To protect the future of the motorcycle sport, make sure that you use your motorcycle legally, be environmentally aware, and respect the rights of others.

When disposing of used oil, other operating and auxiliary fluids, and used components, comply with the laws and regulations of the respective country.

Because motorcycles are not subject to the EU regulations governing the disposal of used vehicles, there are no legal regulations that pertain to the disposal of an end-of-life motorcycle. Your authorized Husqvarna Motorcycles dealer will be glad to advise you.

2.10 Owner's Manual

It is important that you read this Owner's Manual carefully and completely before making your first trip. The Owner's Manual contains useful information and many tips on how to operate, handle, and service your motorcycle. This is the only way to find out how best to customize the vehicle for your own use and how you can protect yourself from injury.

Info

Store the Owner's Manual on your terminal device, for example, so that you can read it whenever you need to.

If you would like to know more about the vehicle or have questions on the material you read, please contact an authorized Husqvarna Motorcycles dealer.

The Owner's Manual is an important component of the vehicle. If the vehicle is sold, the Owner's Manual must be downloaded again by the new owner.

The Owner's Manual can be downloaded several times using the QR code or the link on the delivery certificate.

The Owner's Manual is also available for download from your authorized Husqvarna Motorcycles dealer and on the Husqvarna Motorcycles website. A printed copy can also be ordered from your authorized Husqvarna Motorcycles dealer.

International Husqvarna Motorcycles website: www.husqvarna-motorcycles.com

3.1 Manufacturer warranty, implied warranty

The work prescribed in the service schedule must only be carried out in an authorized Husqvarna Motorcycles workshop and confirmed in the **Husqvarna Motorcycles Dealer.net**, as otherwise all warranty claims will be void. Damage or secondary damage caused by tampering with and/or conversions on the vehicle are not covered by the manufacturer warranty.

3.2 Fuel, auxiliary substances



Note

Environmental hazard Improper handling of fuel is a danger to the environment.

- Do not allow fuel to enter the groundwater, the soil, or the sewage system.

Use fuels and auxiliary substances in accordance with the Owner's Manual and specification.

3.3 Spare parts, Husqvarna Motorcycles technical accessories

For your own safety, only use spare parts and accessory products that are approved and/or recommended by Husqvarna Motorcycles and have them installed by an authorized Husqvarna Motorcycles workshop. Husqvarna Motorcycles accepts no liability for other products and any resulting damage or loss.

The article numbers of some spare parts and accessory products are specified in parentheses in the descriptions. Your authorized Husqvarna Motorcycles dealer will be glad to advise you.

The current Husqvarna Motorcycles technical accessories for your vehicle are available from your authorized Husqvarna Motorcycles dealer and on the Husqvarna Motorcycles website.

International Husqvarna Motorcycles website: www.husqvarna-motorcycles.com

3.4 Service

A prerequisite for perfect operation and prevention of premature wear is that the service, care, and tuning work on the engine and chassis is properly carried out as described in the Owner's Manual. An incorrect suspension setting can lead to damage and breakage of chassis components.

Use of the vehicle under difficult conditions, such as on sand or on wet, dusty and muddy surfaces, can result in significantly increased wear of components, such as the drive train, brake system, air filter or suspension components. For this reason, it may be necessary to inspect or replace parts before the next scheduled service.

It is imperative that you adhere to the stipulated run-in times and service intervals. If you observe these exactly, you will ensure a much longer service life for your motorcycle.

The relevant mileage or time interval is whichever occurs first.

3.5 Figures

The figures contained in the manual may depict special equipment.

In the interest of clarity, some components may be shown disassembled or may not be shown at all. It is not always necessary to disassemble the component to perform the activity in question. Please follow the instructions in the text.

3 IMPORTANT NOTES

3.6 Customer service

Your authorized Husqvarna Motorcycles dealer will be happy to answer any questions you may have regarding your vehicle and Husqvarna Motorcycles.

A list of authorized Husqvarna Motorcycles dealers can be found on the Husqvarna Motorcycles website. International Husqvarna Motorcycles website: www.husqvarna-motorcycles.com

4.1 View of vehicle, front left (example)

- ❶ Clutch lever (📖 p. 17)
- ❷ Fuel tank filler cap
- ❸ Air filter box cover
- ❹ Engine number (📖 p. 15)
- ❺ Side stand (📖 p. 24)
- ❻ Shift lever (📖 p. 23)

4 VIEW OF VEHICLE

4.2 View of vehicle, rear right (example)



- ① 2-stroke oil tank cap
- ② Stop button (📖 p. 17) (TE 150i EU)
- ② Stop button (📖 p. 18) (TE 150i US)
- ② Horn button (📖 p. 18) (TE 150i EU)
- ② Light switch (📖 p. 18) (TE 150i EU)
- ② Turn signal switch (📖 p. 19) (TE 150i EU)
- ③ Start button (📖 p. 19) (TE 150i US)
- ④ Throttle grip (📖 p. 17)
- ⑤ Hand brake lever (📖 p. 17)
- ⑥ Kick starter lever (📖 p. 24)
- ⑦ Foot brake lever (📖 p. 24)

5.1 Vehicle identification number

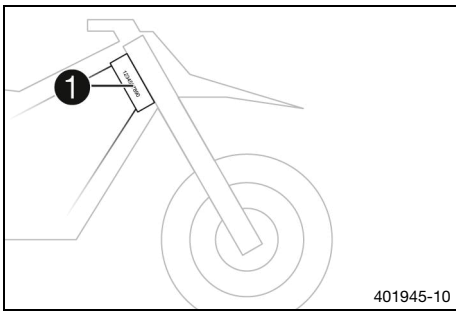

The vehicle identification number ❶ is stamped on the right side of the steering head.

5.2 Type label (TE 150i EU)

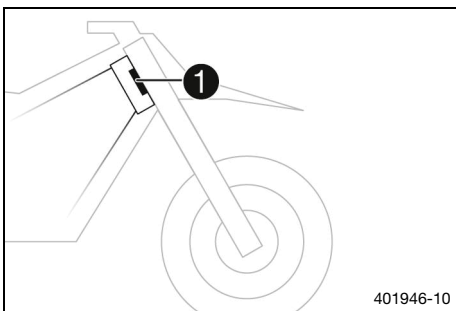

Type label ❶ is fixed to the front of the steering head.

5.3 Key number (TE 150i EU)

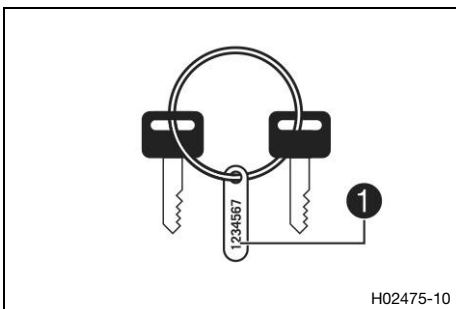

Key number ❶ for the steering lock is stamped on a tag on the key ring.

5.4 Engine number

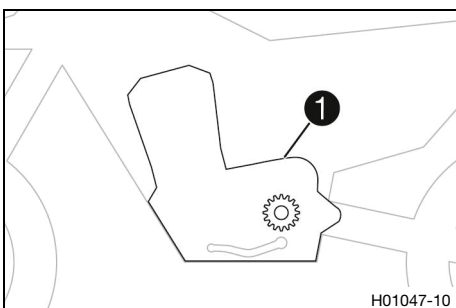

The engine number ❶ is embossed on the left side of the engine above the engine sprocket.

5 SERIAL NUMBERS

5.5 Fork article number

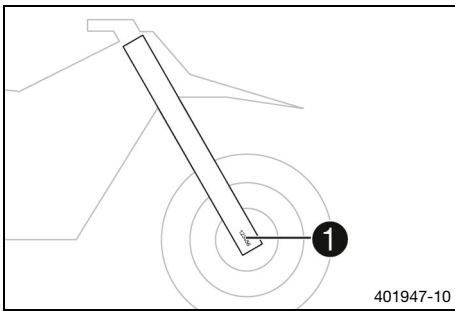

Fork article number ❶ is stamped on the inside of the axle clamp.

5.6 Shock absorber article number

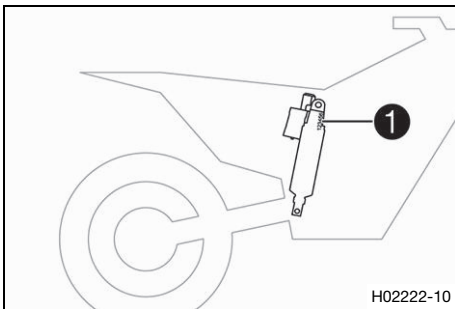

Shock absorber article number ❶ is stamped on the top of the shock absorber above the adjusting ring towards the engine side.

6.1 Clutch lever

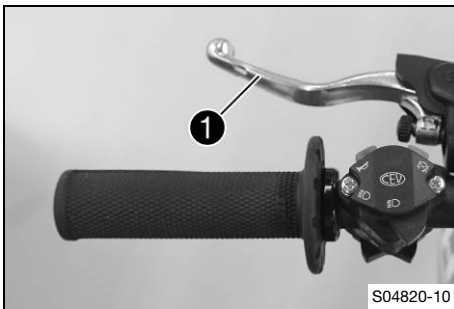

Clutch lever ❶ is fitted on the handlebar on the left. The clutch is activated hydraulically and adjusts itself automatically.

6.2 Hand brake lever

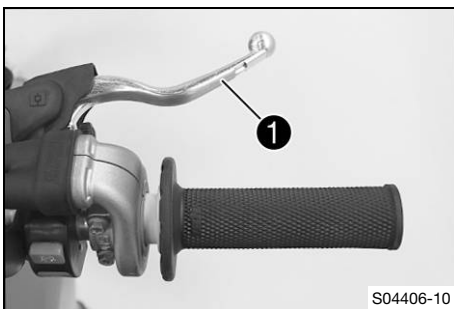

Hand brake lever ❶ is fitted on the right side of the handlebar. The front brake is engaged using the hand brake lever.

6.3 Throttle grip

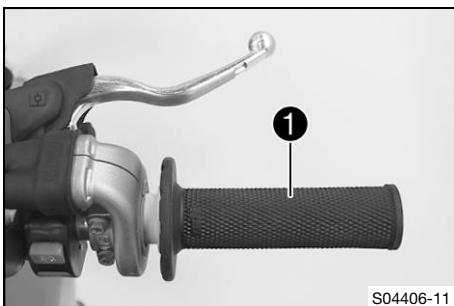

The throttle grip ❶ is fitted on the right side of the handlebar.

6.4 Stop button (TE 150i EU)



The stop button ❶ is fitted on the left side of the handlebar.

Possible states

- The stop button ☒ is in the basic position – In this position, the ignition circuit is closed and the engine can be started.
- Stop button ☒ pressed – In this position, the ignition circuit is interrupted, a running engine stops, and a non-running engine will not start.

6.5 Stop button (TE 150i US)

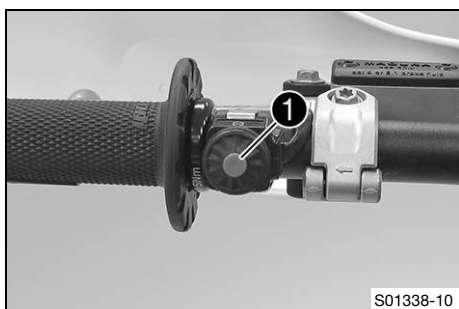

The stop button ❶ is fitted on the left side of the handlebar.

Possible states

- The stop button ☒ is in the basic position – In this position, the ignition circuit is closed and the engine can be started.
- Stop button ☒ pressed – In this position, the ignition circuit is interrupted, a running engine stops, and a non-running engine will not start.

6.6 Horn button (TE 150i EU)



Horn button ❶ is fitted on the left side of the handlebar.

Possible states

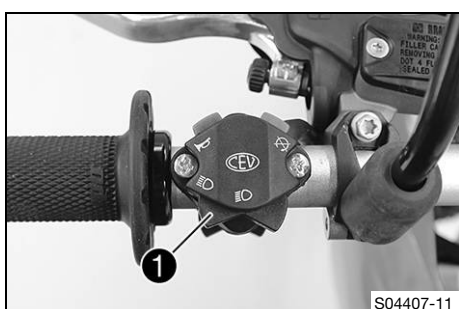

- The horn button ☒ is in the basic position
- The horn button ☒ is pressed – The horn is operated in this position.

6.7 Light switch (TE 150i EU)



Light switch ❶ is fitted on the left side of the handlebar.

Possible states

	Low beam on – Light switch is in the central position. In this position, the low beam and tail light are switched on.
	High beam on – Light switch is turned to the left. In this position, the high beam and tail light are switched on.

6.8 Light switch (TE 150i US)



The light switch ❶ is located to the left of the combination instrument.

Possible states

- Light off – Light switch is pressed in up to the stop. In this position, the light is switched off.
- Light on – Light switch is pulled out to the stop. In this position, the low beam and tail light are switched on.

6.9 Turn signal switch (TE 150i EU)

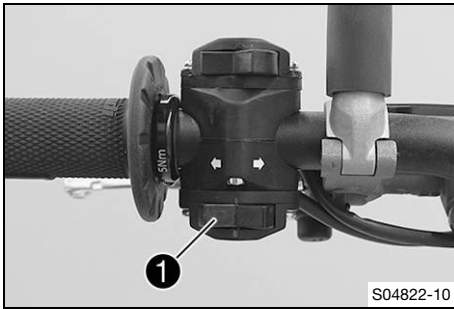

The turn signal switch ❶ is fitted on the left side of the handlebar.

Possible states

	Turn signal light off – The turn signal switch is in the central position.
←	Left turn signal on – The turn signal switch is turned to the left.
→	Right turn signal on – The turn signal switch is turned to the right.

6.10 Emergency OFF switch (TE 150i EU)

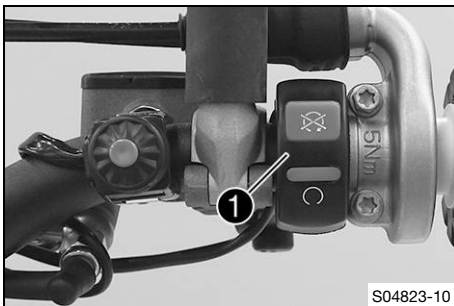

The emergency OFF switch ❶ is fitted on the right side of the handlebar.

Possible states

⊗	Ignition off – In this position, the ignition circuit is interrupted, a running engine stops, and a non-running engine will not start.
○	Ignition on – In this position, the ignition circuit is closed and the engine can be started.

6.11 Start button (TE 150i EU)

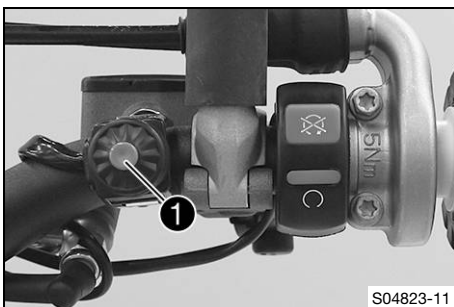

Start button ❶ is fitted on the right side of the handlebar.

Possible states

- The start button ② is in the basic position
- The start button ② is pressed – In this position, the starter motor is actuated.

6.12 Start button (TE 150i US)

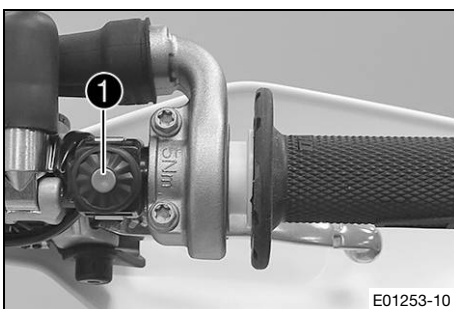

Start button ❶ is fitted on the right side of the handlebar.

Possible states

- The start button ② is in the basic position
- The start button ② is pressed – In this position, the starter motor is actuated.

6.13 Map switch

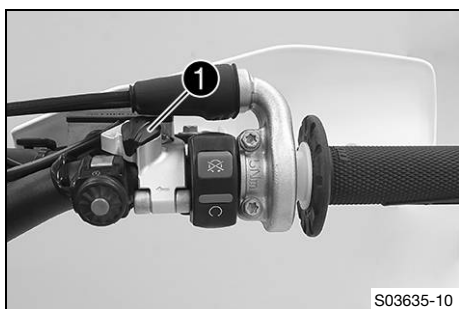

The map switch **1** is fitted on the right side of the handlebar.

Possible states

- Map switch in position **I** – The ignition timing map **Performance** is active in this position.
- Map switch in position **II** – The ignition timing map **Soft** is active in this position.

The engine characteristic can be altered with the map switch.

i Info

The map switch has no function in the homologated (restricted) condition of the motorcycle.

6.14 Overview of indicator lamps (TE 150i EU)



Possible states

	Turn signal indicator lamp flashes green – The turn signal is switched on.
	The high beam indicator lamp lights up blue – The high beam is switched on.
	Malfunction indicator lamp lights up/flashes yellow – The OBD has detected a malfunction in the vehicle electronics. Come safely to a halt, and contact an authorized Husqvarna Motorcycles workshop.
	The fuel level warning lamp lights up yellow – The fuel level has reached the reserve mark.
	The oil level warning lamp lights up red – Oil level has reached the MIN marking. Ride for no more than until the remaining fuel in the tank is depleted and at the next opportunity refuel with 2-stroke oil.

6.15 Overview of indicator lamps (TE 150i US)



Possible states

	High beam indicator lamp – inoperative
	Malfunction indicator lamp lights up/flashes yellow – The OBD has detected a malfunction in the vehicle electronics. Come safely to a halt, and contact an authorized Husqvarna Motorcycles workshop.
	The fuel level warning lamp lights up yellow – The fuel level has reached the reserve mark.
	The oil level warning lamp lights up red – Oil level has reached the MIN marking. Ride for no more than until the remaining fuel in the tank is depleted and at the next opportunity refuel with 2-stroke oil.

6.16 Opening fuel tank filler cap



Danger

Fire hazard Fuel is highly flammable.

The fuel in the fuel tank expands when warm and can escape if overfilled.

- Do not fuel the vehicle in the vicinity of open flames or lit cigarettes.
- Switch off the engine for refueling.
- Make sure that no fuel is spilled; particularly not on hot parts of the vehicle.
- If any fuel is spilled, wipe it off immediately.
- Observe the specifications for refueling.



Warning

Danger of poisoning Fuel is poisonous and a health hazard.

- Avoid skin, eye and clothing contact with fuel.
- Immediately consult a doctor if you swallow fuel.
- Do not inhale fuel vapors.
- In case of skin contact, rinse the affected area with plenty of water.
- Rinse the eyes thoroughly with water, and consult a doctor in case of fuel contact with the eyes.
- Change your clothing in case of fuel spills on them.
- Keep fuels correctly in a suitable canister, and out of the reach of children.



Note

Environmental hazard Improper handling of fuel is a danger to the environment.

- Do not allow fuel to enter the groundwater, the soil, or the sewage system.

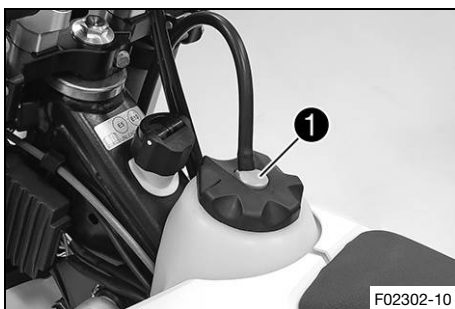

- Press release button ①, turn the fuel tank filler cap counter-clockwise, and lift it off.

6.17 Closing the fuel tank filler cap

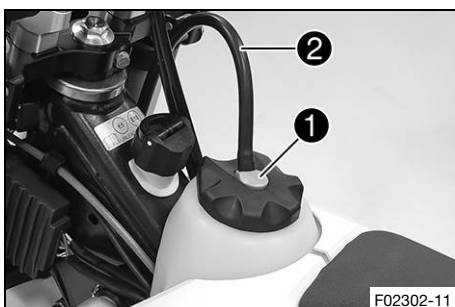

- Mount the fuel tank filler cap and turn it clockwise until release button ① engages.



Info

Route fuel tank breather hose ② without kinks.

6.18 Opening 2-stroke oil tank cap



- Fold loop ① upward.
- Turn the 2-stroke oil tank cap counterclockwise and pull it up.

6.19 Closing 2-stroke oil tank cap

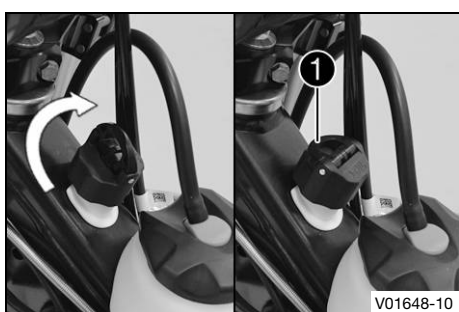

- Put the 2-stroke oil tank cap on and turn it clockwise.
- Fold loop ① down.
- ✓ The 2-stroke oil tank cap engages.

6.20 Cold start button

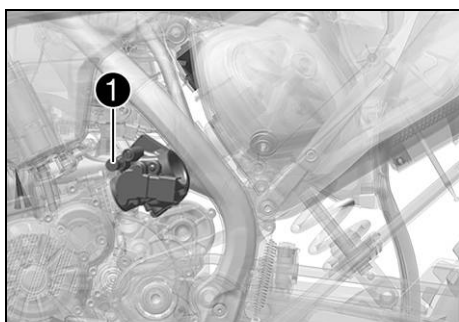

The cold start button ① is fitted on the side of the throttle valve body.

If the engine is cold and the ambient temperature is low, the electronic fuel injection system extends the injection time. To help the engine burn the increased fuel quantity, it must be supplied with additional oxygen by pulling the cold start button.

i Info

If the engine is warm, the cold start button must be deactivated.

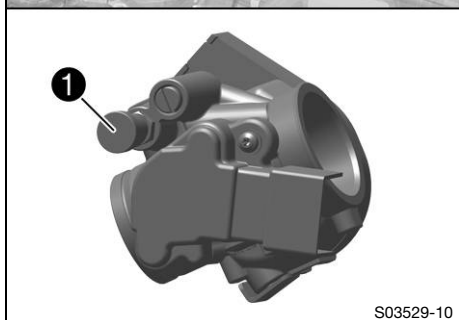

Possible states

- The cold start button is activated – The cold start button is pulled out all the way and turned by a ¼ turn.
- The cold start button is deactivated – A further ¼ turn returns the cold start button back to the basic position.

6.21 Idle speed adjusting screw

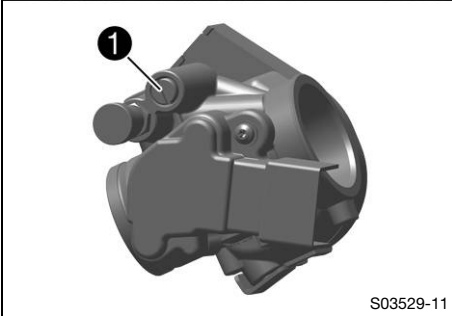

The idle setting of the throttle valve body substantially influences the vehicle's starting behavior, a stable idle speed, and the vehicle's response when the throttle is opened. An engine with a correctly set idle speed is easier to start than an engine with the idle speed set incorrectly. The idle speed is adjusted using the idle speed adjusting screw ①.

i Info

If the idle speed is high, the engine is slow to run, the engine brake is low and the throttle response is aggressive, the adjustment screw must be turned clockwise. If the idle speed is low, the engine is running fast, the engine brake is high and the throttle response is not clean, the adjusting screw must be turned counterclockwise.

6.22 Shift lever

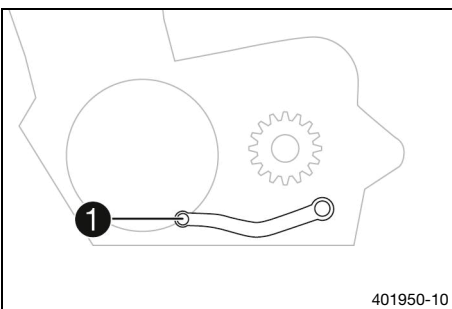

Shift lever ① is mounted on the left side of the engine.

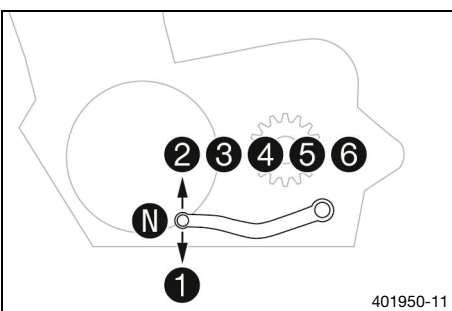

The gear positions can be seen in the photograph. The neutral or idle position is between the first and second gears.

6.23 Kick starter lever

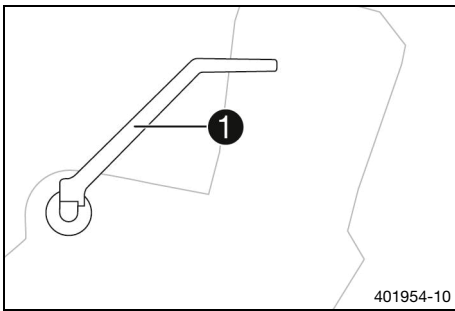

Kick starter lever **1** is fitted on the right side of the engine. The top part of the kick starter lever pivots.

i Info

Before riding, swing the top part of the kick starter inward toward the engine.

6.24 Foot brake lever

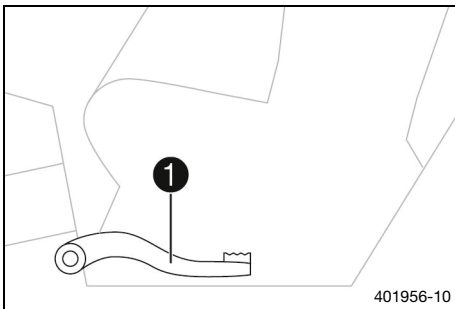

The foot brake lever **1** is located in front of the right footrest. The foot brake lever is used to activate the rear brake.

6.25 Side stand

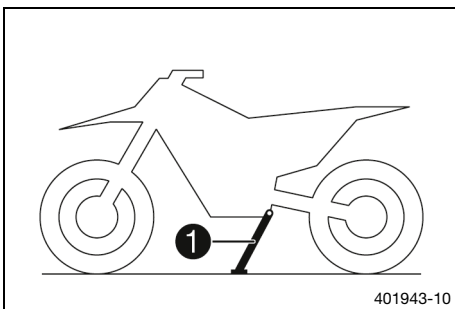

The side stand **1** is located on the left of the vehicle.

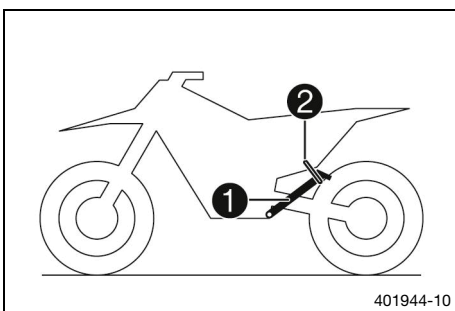

The side stand is used for parking the motorcycle.

i Info

When you are riding, side stand **1** must be folded up and secured with rubber strap **2**.

6.26 Steering lock (TE 150i EU)

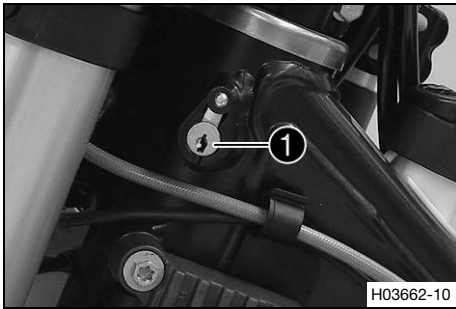

Steering lock ① is fitted on the left side of the steering head. The steering lock is used to lock the steering. Steering, and therefore riding, is no longer possible.

6.27 Locking the steering (TE 150i EU)

Note

Danger of damage The parked vehicle can roll away or fall over.

- Park the vehicle on a firm and level surface.

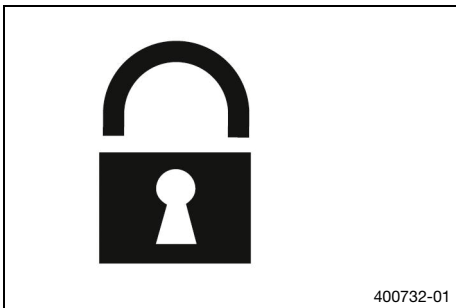

- Park the vehicle.
- Turn handlebar as far as possible to the right.
- Insert the key for the steering lock into the steering lock, turn it to the left, press it in, and turn it to the right. Pull out the key for the steering lock.
- ✓ Steering is no longer possible.

i Info
Never leave the key for the steering lock in the steering lock.



6.28 Unlocking the steering (TE 150i EU)

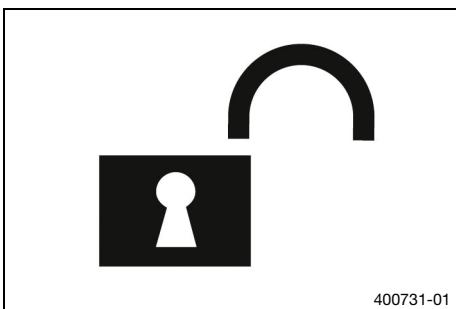

- Insert the key for the steering lock into the steering lock, turn it to the left, pull it out, and turn it to the right. Pull out the key for the steering lock.
- ✓ The handlebar can now be moved again.

i Info
Never leave the key for the steering lock in the steering lock.



7 COMBINATION INSTRUMENT

7.1 Overview

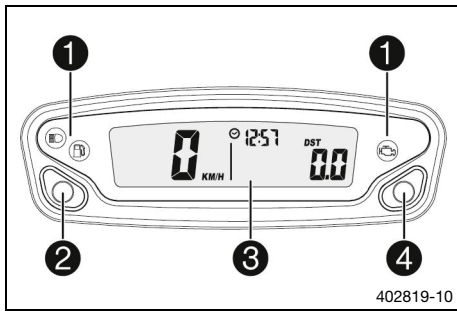

- ① Overview of indicator lamps (🔌 p. 20) (TE 150i EU)
- ① Overview of indicator lamps (🔌 p. 20) (TE 150i US)
- ② Left button
- ③ Display
- ④ Right button

7.2 Activation

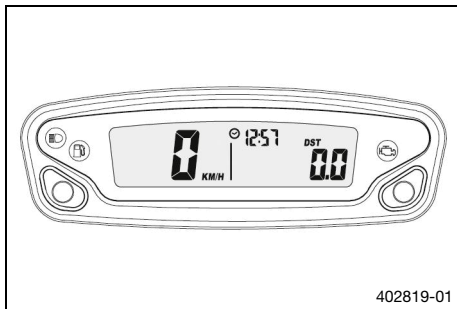

Activating combination instrument

The combination instrument is activated when one of the buttons is pressed or an impulse comes from the wheel speed sensor.

7.3 Messages on the combination instrument

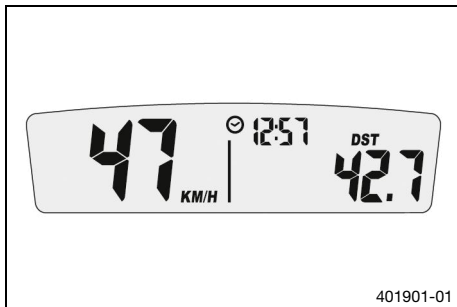

Possible states

	Battery voltage of the combination instrument – The battery voltage of the combination instrument is too low. Change combination instrument battery.
	Service – A service is due. Contact an authorized Husqvarna Motorcycles workshop.

7.4 Adjusting the combination instrument

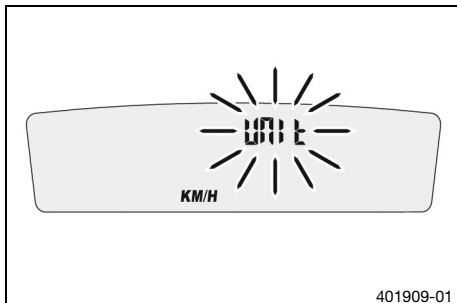

Condition

The motorcycle is stationary.

- Press both buttons for 3–5 seconds.
 - ✓ The Setup menu is displayed. The **UNIT** display flashes.
- Press one of the buttons to select **UNIT** for the speed in kilometers **KM/H** or miles **M/H**.

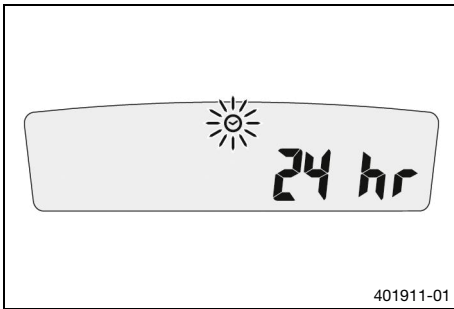

- Wait for 5 seconds.
- ✓ The combination instrument changes to the next menu item. The ☀ symbol flashes.
- Press one of the buttons to select the 24h or 12h display of the clock.

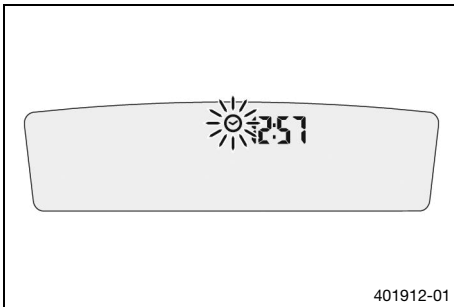

- Wait for 5 seconds.
- ✓ The combination instrument changes to the next menu item. The ☀ symbol flashes.

Resetting the time

- Press the left button.
- ✓ The value decreases.

Advancing the time

- Press the right button.
- ✓ The value increases.

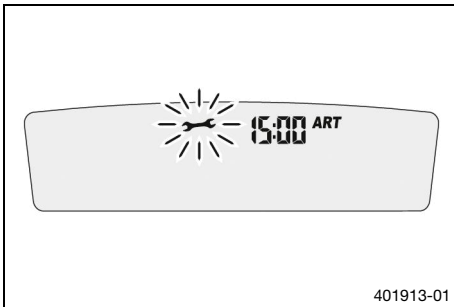

- Wait for 5 seconds.
- ✓ The combination instrument changes to the next menu item. The 🛠 symbol flashes.
- Set the service.

Shortening the service interval

- Press the left button.
- ✓ The value decreases.

Extending the service interval

- Press the right button.
- ✓ The value increases.

Switching off the service interval display

- Press and hold the left button.
- ✓ **off** appears on the display.

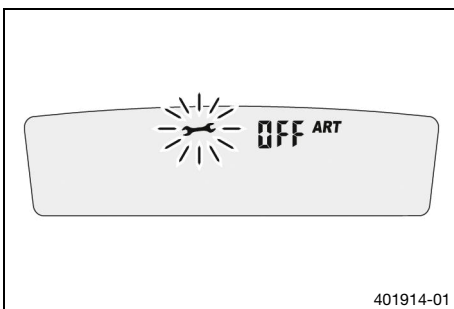

7.5 Setting the kilometers or miles



Info

If the unit is changed, the value **ODO** is retained and converted accordingly.

Condition

The motorcycle is stationary.

7 COMBINATION INSTRUMENT

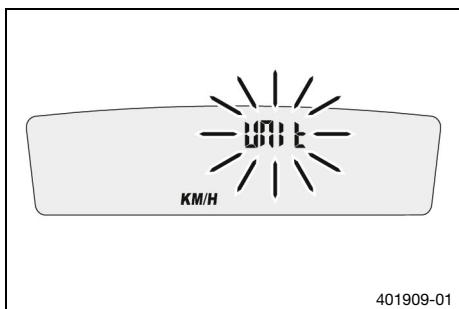

- Press both buttons for 3–5 seconds.
 - ✓ The Setup menu is displayed. The **UNIT** display flashes.
- Press one of the buttons to select **UNIT** for the speed in kilometers **KM/H** or miles **M/H**.

7.6 Setting the clock

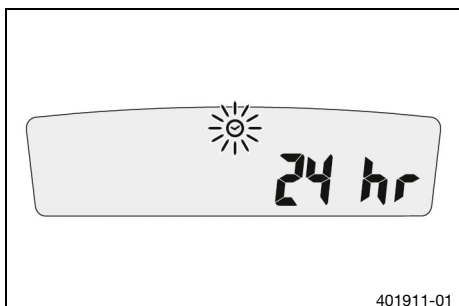

Condition

The motorcycle is stationary.

- Press both buttons for 3–5 seconds.
 - ✓ The Setup menu is displayed. The **UNIT** display flashes.
- Wait for the menu of the clock ☀ to flash.
- Press one of the buttons to select the 24h or 12h display of the clock.

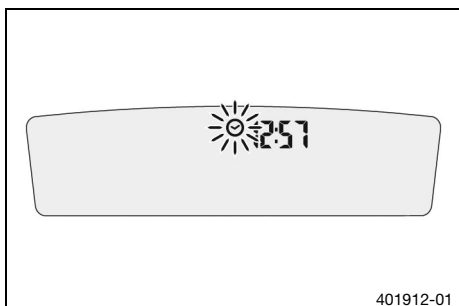

- Wait for 5 seconds.
 - ✓ The combination instrument changes to the next menu item. The ☀ symbol flashes.

Resetting the time

- Press the left button.
 - ✓ The value decreases.

Advancing the time

- Press the right button.
 - ✓ The value increases.

7.7 Setting the service display

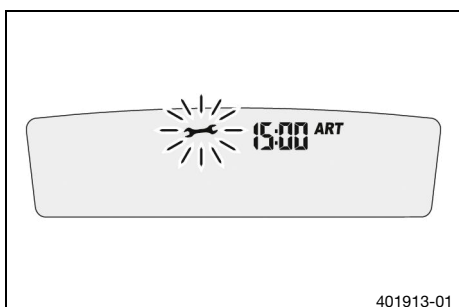

Condition

The motorcycle is stationary.

- Press both buttons for 3–5 seconds.
 - ✓ The Setup menu is displayed. The **UNIT** display flashes.
- Wait for the menu of the service display ⚙ to flash.
- Set the service.

Shortening the service interval

- Press the left button.
 - ✓ The value decreases.

Extending the service interval

- Press the right button.
 - ✓ The value increases.

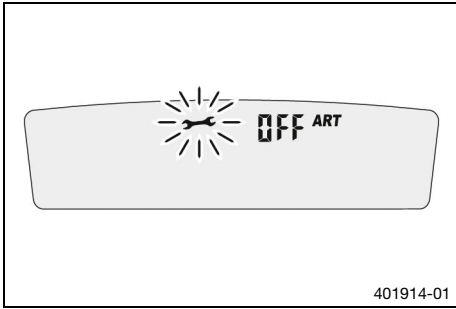

Switching off the service interval display

- Press and hold the left button.
- ✓ **off** appears in the display.

7.8 Speed, time, and DST distance 1

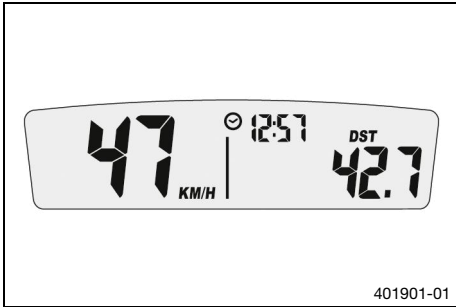

- Press one of the buttons until **DST** appears on the combination instrument.

KM/H or **M/H** shows the speed.

⌚ shows the time.

DST shows the distance since the last reset, such as between two refueling stops.

i Info

If the value of 39999.9 is exceeded, **DST** is automatically reset to 0.0.

Press the left button briefly.	Next display mode
Press the left button for 3 – 5 seconds.	DST can be preset to a value between 0.0 and 39999.9 by pressing the buttons.
Press the right button briefly.	Next display mode
Press the right button for 3 – 5 seconds.	DST is reset to 0.0.

7.9 Speed, time, and DST2 distance 2

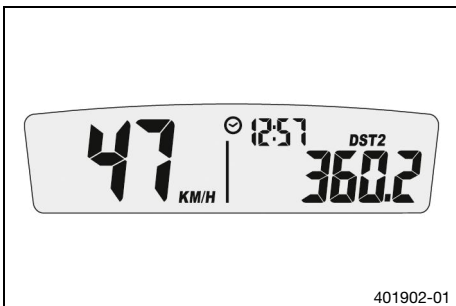

- Press one of the buttons until **DST2** appears on the combination instrument.

KM/H or **M/H** shows the speed.

⌚ shows the time.

DST2 shows the distance 2 since the last reset, such as between two refueling stops.

i Info

If the value of 39999.9 is exceeded, **DST2** is automatically reset to 0.0.

Press the left button briefly.	Next display mode
--------------------------------	-------------------

7 COMBINATION INSTRUMENT

Press the left button for 3 – 5 seconds.	DST2 can be preset to a value between 0.0 and 39999.9 by pressing the buttons.
Press the right button briefly.	Next display mode
Press the right button for 3 – 5 seconds.	DST2 is reset to 0.0.

7.10 AVG average speed, ART operating hours, and ODO total distance covered

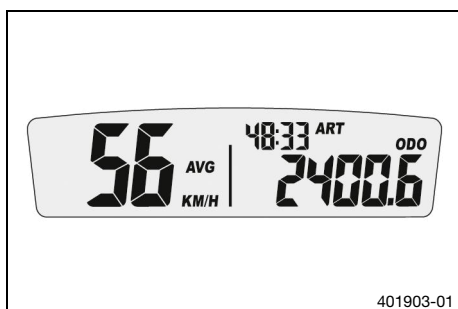

- Press one of the buttons until **AVG**, **ART** and **ODO** appear on the combination instrument.

AVG shows the average speed since the last reset.

ART shows the operating hours.

ODO shows the total distance covered.

Press the left button briefly.	Next display mode
Press the left button for 3 – 5 seconds.	The OPEN END WRENCH SYMBOL shows the remaining operating hours until the next service is due.
Press the right button briefly.	Next display mode
Press the right button for 3 – 5 seconds.	AVG is reset to 0.0.

8.1 Advice on preparing for first use



Danger

Danger of accidents A rider who is not fit to ride poses a danger to him or herself and others.

- Do not operate the vehicle if you are not fit to ride due to alcohol, drugs or medication.
- Do not operate the vehicle if you are physically or mentally impaired.



Warning

Risk of injury Missing or poor protective clothing presents an increased safety risk.

- Wear appropriate protective clothing such as helmet, boots, gloves as well as trousers and a jacket with protectors on all rides.
- Always wear protective clothing that is in good condition and meets the legal regulations.



Warning

Danger of crashing Different tire tread patterns on the front and rear wheel impair the handling characteristic.

Different tire tread patterns can make the vehicle significantly more difficult to control.

- Make sure that only tires with a similar tire tread pattern are fitted to the front and rear wheel.



Warning

Danger of accidents An unadapted riding style impairs the handling characteristic.

- Adapt your riding speed to the road conditions and your riding ability.



Warning

Danger of accidents The vehicle is not designed to carry passengers.

- Do not ride with a passenger.



Warning

Danger of accidents The brake system fails in the event of overheating.

If the foot brake lever is not released, the brake linings drag continuously.

- Take your foot off the foot brake lever if you do not want to brake.



Warning

Danger of accidents Total weight and axle loads influence the handling characteristic.

- Do not exceed the maximum permissible overall weight or the axle loads.



Warning

Risk of misappropriation People who act without authorization endanger themselves and others.

- Do not leave the vehicle unattended if the engine is running.
- Protect the vehicle against access by unauthorized persons.



Info

When using your motorcycle, remember that others may feel disturbed by excessive noise.

- Make sure that the pre-sale inspection work has been carried out by an authorized Husqvarna Motorcycles workshop.
 - ✓ You will receive a delivery certificate when the vehicle is handed over.
- Before riding for the first time, read the entire Owner's Manual carefully.
- Get to know the controls.
- Adjust the basic position of the clutch lever. (📖 p. 83)

8 PREPARING FOR USE

- Adjust the basic position of the hand brake lever. (📖 p. 87)
- Adjust the basic position of the foot brake lever. 🗑️ (📖 p. 93)
- Adjust the basic position of the shift lever. 🗑️ (📖 p. 128)
- Get used to the handling characteristics of the motorcycle on a suitable surface before undertaking more challenging trips.

Info

When offroad, it is recommended that you are accompanied by another person on another vehicle so that you can help each other.

- Try also to ride as slowly as possible and in a standing position to get a better feel for the motorcycle.
- Do not make any off-road trips that exceed your ability and experience.
- Hold the handlebar firmly with both hands and keep your feet on the footrests when riding.
- If you carry luggage, make sure you secure it firmly as close as possible to the center of the vehicle and ensure even weight distribution between the front and rear wheels.

Info

Motorcycles react sensitively to any changes of weight distribution.

- The maximum permissible overall weight and the maximum permissible axle loads must not be exceeded.
Guideline

Maximum permissible overall weight	335 kg (739 lb.)
Maximum permissible front axle load	145 kg (320 lb.)
Maximum permissible rear axle load	190 kg (419 lb.)

- Check the spoke tension. (📖 p. 103)

Info

The spoke tension must be checked after half an hour of operation.

- Run the engine in. (📖 p. 32)

8.2 Running in the engine

- During the running-in phase, do not exceed the specified engine performance.

Guideline

Maximum engine performance	
During the first 3 operating hours	< 70 %
During the first 5 operating hours	< 100 %

- Avoid fully opening the throttle!
- Check the idle speed regularly.

Guideline

Idle speed	1,400 ... 1,500 rpm
------------	---------------------

Info

The idle speed may change during the run-in time.

- » If the idle speed changes:
 - Adjust the idle speed. 🗑️ (📖 p. 126)

8.3 Starting power of lithium-ion batteries at low temperatures

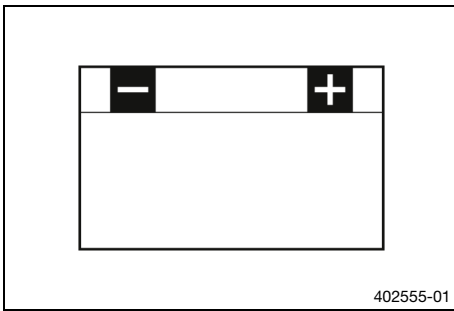

Lithium-ion batteries are far lighter than lead batteries, have a low self-discharge rate, and have more starting power at temperatures over 15 °C (60 °F). At low temperatures, however, the starting power of lithium-ion batteries drops to below that of lead batteries.

Multiple starting attempts may be needed. Press the start button for 5 seconds, and wait 30 seconds between attempts. The pauses are necessary so that the heat created can distribute through the lithium-ion battery and the 12-V battery is not damaged.

If the charged lithium-ion battery is unable to actuate the starter motor when temperatures are below 15 °C (60 °F), the battery is not faulty, but needs to be warmed up internally to increase its starting power (current output).

The starting power increases as the battery warms up.

8.4 Preparing the vehicle for difficult operating conditions

i Info

Use of the vehicle under difficult conditions, such as on sand or on wet and muddy surfaces, can result in significantly increased wear of components, such as the drive train, brake system, or suspension components. For this reason, it may be necessary to inspect or replace parts before the next scheduled service.

- Clean the air filter and air filter box. 📖 (p. 70)

i Info

Check the air filter approx. every 30 minutes.

- Check the electrical connector for humidity and corrosion and to ensure it is firmly seated.
 - » If humidity, corrosion, or damage is found:
 - Clean and dry the connector, or change it if necessary.

Difficult operating conditions are:

- Rides on dry sand. 📖 (p. 33)
- Rides on wet sand. 📖 (p. 35)
- Rides on wet and muddy circuits. 📖 (p. 36)
- Rides at high temperatures or slow riding. 📖 (p. 36)
- Riding at low temperatures and in snow. 📖 (p. 37)



8.5 Preparing the vehicle for rides on dry sand



- Check the radiator cap.

Value on the radiator cap	1.8 bar (26 psi)
---------------------------	------------------

- » If the indicated value does not correspond to the setpoint value:



Warning

Danger of scalding During motorcycle operation, the coolant gets very hot and is under pressure.

- Do not open the radiator, the radiator hoses or other cooling system components if the engine or the cooling system are at operating temperature.
- Allow the cooling system and the engine to cool down before you open the radiator, the radiator hoses or other components of the cooling system.
- In the event of scalding, rinse the area affected immediately with lukewarm water.



M01104-01

- Change the radiator cap.
- Mount the air filter dust cover.

Air filter dust cover (79006920000)



Info

Observe the fitting instructions for Husqvarna Motorcycles technical accessories.



M01105-01

- Mount the air filter sand cover.

Air filter sand cover (79006922000)



Info

Observe the fitting instructions for Husqvarna Motorcycles technical accessories.



600868-01

- Clean the chain.
- Mount the steel sprocket.
- Grease the chain.

Universal oil spray (📖 p. 158)

- Clean the radiator fins.
- Straighten the bent radiator fins carefully.

Condition

Regular use in sand

- Change the piston every 10 operating hours.

8.6 Preparing the vehicle for rides on wet sand



- Check the radiator cap.

Value on the radiator cap	1.8 bar (26 psi)
---------------------------	------------------

- » If the indicated value does not correspond to the setpoint value:



Warning

Danger of scalding During motorcycle operation, the coolant gets very hot and is under pressure.

- Do not open the radiator, the radiator hoses or other cooling system components if the engine or the cooling system are at operating temperature.
- Allow the cooling system and the engine to cool down before you open the radiator, the radiator hoses or other components of the cooling system.
- In the event of scalding, rinse the area affected immediately with lukewarm water.

- Change the radiator cap.



- Mount the air filter rain cover.

Air filter rain cover (79006921000)



Info

Observe the fitting instructions for Husqvarna Motorcycles technical accessories.



- Clean the chain.
- Mount the steel sprocket.
- Grease the chain.

Universal oil spray (📖 p. 158)

- Clean the radiator fins.
- Straighten the bent radiator fins carefully.

Condition

Regular use in sand

- Change the piston every 10 operating hours.

8.7 Preparing the vehicle for rides on wet and muddy circuits



- Mount the air filter rain cover.

Air filter rain cover (79006921000)



Info

Observe the fitting instructions for Husqvarna Motorcycles technical accessories.



- Mount the steel sprocket.
- Clean the motorcycle. (📖 p. 138)
- Straighten the bent radiator fins carefully.

8.8 Preparing vehicle for high temperatures or slow riding



- Check the radiator cap.

Value on the radiator cap	1.8 bar (26 psi)
---------------------------	------------------

- » If the indicated value does not correspond to the setpoint value:



Warning

Danger of scalding During motorcycle operation, the coolant gets very hot and is under pressure.

- Do not open the radiator, the radiator hoses or other cooling system components if the engine or the cooling system are at operating temperature.
- Allow the cooling system and the engine to cool down before you open the radiator, the radiator hoses or other components of the cooling system.
- In the event of scalding, rinse the area affected immediately with lukewarm water.

- Change the radiator cap.



600868-01

- Adjust the secondary drive to the road conditions.



Info

The transmission oil heats up quickly when the clutch is operated frequently due to an excessively high secondary drive.

- Clean the chain.
- Clean the radiator fins.
- Straighten bent radiator fins carefully.
- Check the coolant level. (📖 p. 119)



8.9 Preparing the vehicle for low temperatures or snow



M01106-01

- Mount the air filter rain cover.

Air filter rain cover (79006921000)



Info

Observe the fitting instructions for Husqvarna Motorcycles technical accessories.



9.1 Checks and maintenance measures when preparing for use

i Info

Before every trip, check the condition of the vehicle and ensure that it is safe to operate. The vehicle must be in perfect technical condition when it is being operated.

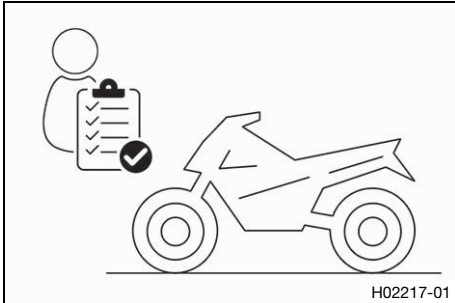

- Check the gear oil level. (📖 p. 135)
- Check the electrical system.
- Check the front brake fluid level. (📖 p. 88)
- Check the rear brake fluid level. (📖 p. 94)
- Check the front brake linings. (📖 p. 89)
- Check the brake linings of the rear brake. (📖 p. 95)
- Check that the brake system is functioning properly.
- Check the coolant level. (📖 p. 119)
- Check the chain for dirt. (📖 p. 77)
- Check the chain, rear sprocket, engine sprocket, and chain guide. (📖 p. 79)
- Check the chain tension. (📖 p. 78)
- Check the tire condition. (📖 p. 102)
- Check tire pressure. (📖 p. 102)
- Check the spoke tension. (📖 p. 103)

i Info

The spoke tension must be checked regularly as incorrect spoke tension will strongly impair riding safety.

- Clean the dust boots of the fork legs. (📖 p. 57)
- Bleed the fork legs. (📖 p. 56)
- Check the air filter.
- Check the settings of all controls and ensure that they can be operated smoothly.
- Check all screws, nuts, and hose clamps regularly for tightness.
- Check the fuel level.
- Check 2-stroke oil level. (📖 p. 130)

9.2 Starting the vehicle



Danger

Danger of poisoning Exhaust gases are toxic and inhaling them may result in unconsciousness and death.

- Always make sure there is sufficient ventilation when running the engine.
- Use effective exhaust extraction when starting or running the engine in an enclosed space.

Note

Engine damage High revving speed with a cold engine negatively impacts the lifespan of the engine.

- Always run the engine warm at a low speed.

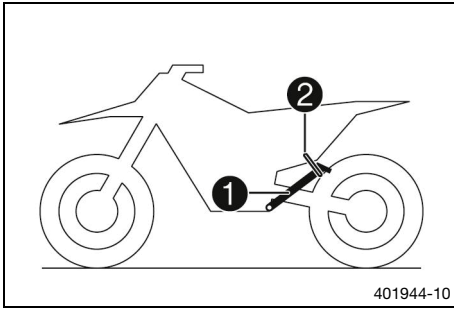

- Take the motorcycle off side stand ① and secure the side stand with rubber strap ②.
- Shift the transmission into neutral.

(TE 150i EU)

- Turn the emergency OFF switch to the position ○.

Condition

Ambient temperature: < 10 °C (< 50 °F)

- Pull the cold start button out all the way and turn it by a ¼ turn.

i Info

If the engine is warm, the cold start button must be deactivated.

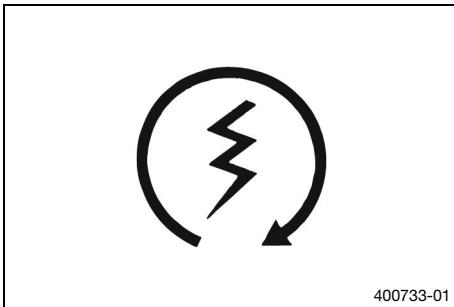

- Press the start button or press the kick starter lever forcefully all the way.

i Info

Do not open the throttle.
Press the start button for a maximum of 5 seconds.
Wait for 30 seconds before a further attempt at starting.
At temperatures below 15 °C (60 °F), several attempts at starting may be necessary to warm-up the lithium-ion battery and thereby increase the starting power.
During the starting process, the malfunction indicator lamp lights up.

9.3 Starting off

i Info

Switch on the light before riding the vehicle. You will be seen earlier by other motorists.
When you are riding, the side stand must be folded up and secured with the rubber strap.

- Pull the clutch lever, shift into first gear, release the clutch lever slowly and at the same time open the throttle carefully.

9.4 Shifting, riding

! Warning

Danger of accidents If you change down at high engine speed, the rear wheel blocks and the engine races.

- Do not change into a low gear at high engine speed.



Warning

Engine failure The engine will not be lubricated unless there is 2-stroke oil in the oil tank. If the oil level warning light lights up, the 2-stroke oil is sufficient for the remaining tank of fuel.

- As soon as the oil level warning light lights up, ride for no longer than until the remaining fuel in the tank is depleted.
- At the next opportunity add 2-stroke oil before you refuel.
- Time the oil pump if the 2-stroke oil hose has been removed or the 2-stroke oil tank has been fully depleted in error.



Info

If you hear unusual noises while riding, stop immediately, switch off the engine, and contact an authorized Husqvarna Motorcycles workshop.

First-gear is used for starting off and for steep inclines.

- Shift into a higher gear when conditions allow (incline, road situation, etc.). To do so, release the throttle while simultaneously pulling the clutch lever, shift into the next gear, release the clutch lever and open the throttle.
- If the cold start function was activated, deactivate the cold start button after the engine has warmed up.
- After reaching maximum speed by fully opening the throttle grip, turn the throttle back so it is $\frac{3}{4}$ open. This will barely reduce the speed, but fuel consumption will be considerably lower.
- Always open the throttle only as much as the engine can handle – abrupt throttle opening increases fuel consumption.
- To shift down, apply the brakes and close the throttle at the same time.
- Pull the clutch lever and shift into a lower gear, release the clutch lever slowly, and either open the throttle or shift again.
- Switch off the engine if running at idle speed or stationary for a long time.

Guideline

≥ 2 min

- Avoid frequent or lengthy slipping of the clutch. This causes the gear oil, engine and cooling system to heat up.
- Ride at a low engine speed instead of at a high engine speed with a slipping clutch.

9.5 Braking



Warning

Danger of accidents Excessively forceful application of the brakes blocks the wheels.

- Adjust application of the brakes to the respective riding situation and riding surface conditions.



Warning

Danger of accidents A spongy pressure point on the front or rear brake reduces braking efficiency.

- Check the brake system and do not continue riding until the problem is eliminated. (Your authorized Husqvarna Motorcycles workshop will be glad to help.)



Warning

Danger of accidents Moisture and dirt impair the brake system.

- Brake carefully several times to dry out and remove dirt from the brake linings and the brake discs.

- On sandy, wet, or slippery surfaces, use the rear brake.

- Braking should always be completed before you go into a bend. Change down to a lower gear appropriate to your road speed.



9.6 Stopping, parking



Warning

Risk of misappropriation People who act without authorization endanger themselves and others.

- Do not leave the vehicle unattended if the engine is running.
- Protect the vehicle against access by unauthorized persons.



Warning

Danger of burns Some vehicle components become very hot when the vehicle is operated.

- Do not touch any parts such as the exhaust system, radiator, engine, shock absorber, or brake system before the vehicle parts have cooled down.
- Let the vehicle parts cool down before you perform any work on the vehicle.

Note

Material damage The vehicle may be damaged by incorrect procedure when parking.

Significant damage may be caused if the vehicle rolls away or falls over.

The components for parking the vehicle are designed only for the weight of the vehicle.

- Park the vehicle on a firm and level surface.
- Ensure that nobody sits on the vehicle when the vehicle is parked on a stand.

Note

Fire hazard Hot vehicle components pose a fire hazard and explosion risk.

- Do not park the vehicle near to materials which are highly flammable or explosive.
- Allow the vehicle to cool down before covering it.

- Apply the brakes on the motorcycle.
- Shift the transmission into neutral.

(TE 150i EU)

- Press and hold the stop button  while the engine is idling until the engine stops.

(TE 150i US)

- Press and hold the stop button  while the engine is idling until the engine stops.
- Park the motorcycle on firm ground.



9.7 Transporting

Note

Danger of damage The parked vehicle can roll away or fall over.

- Park the vehicle on a firm and level surface.

Note

Fire hazard Hot vehicle components pose a fire hazard and explosion risk.

- Do not park the vehicle near to materials which are highly flammable or explosive.
- Allow the vehicle to cool down before covering it.

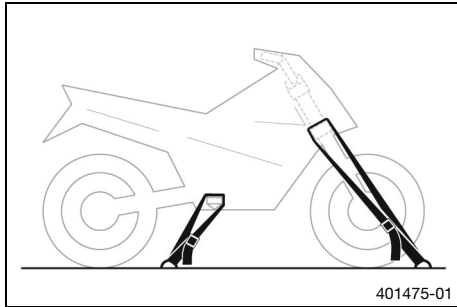

- Switch off the engine.
- Use tension belts or other suitable devices to secure the motorcycle against falling over or rolling away.

9.8 Refueling



Danger

Fire hazard Fuel is highly flammable.

The fuel in the fuel tank expands when warm and can escape if overfilled.

- Do not fuel the vehicle in the vicinity of open flames or lit cigarettes.
- Switch off the engine for refueling.
- Make sure that no fuel is spilled; particularly not on hot parts of the vehicle.
- If any fuel is spilled, wipe it off immediately.
- Observe the specifications for refueling.



Warning

Danger of poisoning Fuel is poisonous and a health hazard.

- Avoid skin, eye and clothing contact with fuel.
- Immediately consult a doctor if you swallow fuel.
- Do not inhale fuel vapors.
- In case of skin contact, rinse the affected area with plenty of water.
- Rinse the eyes thoroughly with water, and consult a doctor in case of fuel contact with the eyes.
- Change your clothing in case of fuel spills on them.

Note

Material damage Inadequate fuel quality causes the fuel filter to quickly become clogged.

In some countries and regions, the available fuel quality and cleanliness may not be sufficient. This will result in problems with the fuel system.

- Refuel only with clean fuel that meets the specified standards. (Your authorized Husqvarna Motorcycles workshop will be glad to help.)



Note

Environmental hazard Improper handling of fuel is a danger to the environment.

- Do not allow fuel to enter the groundwater, the soil, or the sewage system.

- Open fuel tank filler cap. (📖 p. 21)

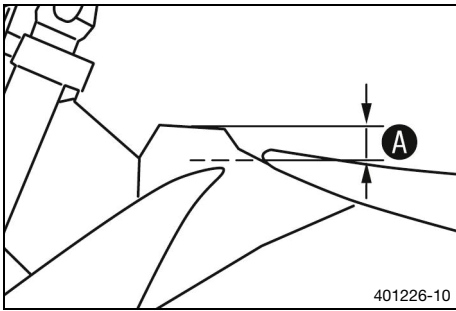

- Fill the fuel tank with fuel up to level **A**.

Guideline

Level A	35 mm (1.38 in)	
Total fuel tank capacity, approx.	8.5 l (2.25 US gal)	Super unleaded (ROZ 95) (📖 p. 156)

i Info
Do not refuel using pre-mixed fuel.

- Close the fuel tank filler cap. (📖 p. 21)

9.9 Adding 2-stroke oil

! Warning

Engine failure The engine will not be lubricated unless there is 2-stroke oil in the oil tank. If the oil level warning light lights up, the 2-stroke oil is sufficient for the remaining tank of fuel.

- As soon as the oil level warning light lights up, ride for no longer than until the remaining fuel in the tank is depleted.
- At the next opportunity add 2-stroke oil before you refuel.
- Time the oil pump if the 2-stroke oil hose has been removed or the 2-stroke oil tank has been fully depleted in error.

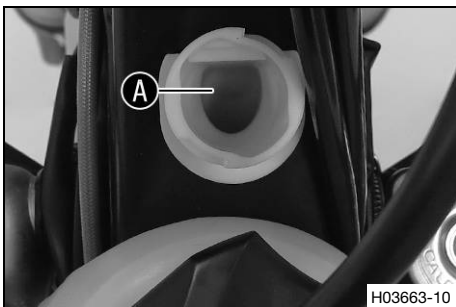

- Open 2-stroke oil tank cap. (📖 p. 22)
- Fill the 2-stroke oil tank up to the lower edge **A** of the filler neck.

Guideline

Only use 2-stroke oil which is appropriate for separate lubrication.		
2-stroke oil tank content approx.	0.6 l (0.6 qt.)	Engine oil, 2-stroke (📖 p. 155)

- Close 2-stroke oil tank cap. (📖 p. 22)

10.1 Additional information

Any further work that results from the compulsory work or from the recommended work must be ordered separately and invoiced separately.

Different service intervals may apply in your country, depending on the local operating conditions.

Individual service intervals and scopes may change in the course of technical developments. The most up-to-date service schedule can always be found on Husqvarna Motorcycles Dealer.net. Your authorized Husqvarna Motorcycles dealer will be glad to advise you.

10.2 Required work

	Every 10 operating hours when used for motorsports			Every 40 operating hours		
				Every 20 operating hours		
				After 5 operating hours		
				After 1 operating hour		
Read out the fault memory using the Husqvarna Motorcycles diagnostics tool. 🛠️	○	○	●	●	●	●
Check that the electrical system is functioning properly.	○		●	●	●	●
Check and charge the 12-V battery. 🛠️			●	●	●	●
Check the front brake linings. (📖 p. 89)			●	●	●	●
Check the brake linings of the rear brake. (📖 p. 95)			●	●	●	●
Check the brake discs. (📖 p. 87)			●	●	●	●
Check the brake lines for damage and leakage.			●	●	●	●
Check the rear brake fluid level. (📖 p. 94)			●	●	●	●
Check the free travel of the foot brake lever. (📖 p. 92)			●	●	●	●
Check the frame. 🛠️ (📖 p. 82)			●	●	●	●
Check the link fork. 🛠️ (📖 p. 82)			●	●	●	●
Check the fork bearing for play. 🛠️			●	●		
Check the shock absorber heim joint for play.			●	●		
Check the shock absorber linkage. 🛠️			●	●		
Check the tire condition. (📖 p. 102)	○		●	●	●	●
Check tire pressure. (📖 p. 102)	○		●	●	●	●
Check the wheel bearing for play.			●	●	●	●
Check the wheel hubs. 🛠️			●	●	●	●
Check the rim run-out. 🛠️	○		●	●		
Check the spoke tension. (📖 p. 103)	○		●	●	●	●
Check the chain, rear sprocket, engine sprocket, and chain guide. (📖 p. 79)			●	●	●	●
Check the chain tension. (📖 p. 78)	○		●	●	●	●
Grease all moving parts (e.g. side stand, hand lever, chain, etc.) and check for smooth operation. 🛠️			●	●	●	●
Check/correct the fluid level of the hydraulic clutch. (📖 p. 84)			●	●	●	●
Check the front brake fluid level. (📖 p. 88)			●	●	●	●
Check the free travel of the hand brake lever. 🛠️			●	●	●	●
Check the steering head bearing for play. (📖 p. 62)	○		●	●		
Change the spark plug and spark plug connector. 🛠️				●	●	
Check the reed valve housing, reed valve and intake flange. 🛠️			●	●		
Change the gear oil. 🛠️ (📖 p. 135)		○		●	●	

	Every 10 operating hours when used for motorsports			
	Every 40 operating hours			
	Every 20 operating hours			
	After 5 operating hours			
	After 1 operating hour			
Check all hoses (e.g. fuel, cooling, bleeder, drainage, etc.) and sleeves for cracking, leaks, and incorrect routing. 🛠️	○	●	●	●
Check the antifreeze and coolant level. (📖 p. 118)	○	●	●	●
Check the cables for damage and for routing without kinks. 🛠️		●	●	●
Check that the throttle cables are undamaged, routed without sharp bends, and set correctly.	○	●	●	●
Clean the air filter and air filter box. 🛠️ (📖 p. 70)		●	●	●
Change the glass fiber yarn filling of the main silencer. 🛠️ (📖 p. 72)		●	●	
Service the fork. 🛠️			●	
Perform the shock absorber service. 🛠️			●	
Check the tightness of the easily accessible, safety-relevant screws and nuts. 🛠️	○	●	●	●
Change the fuel screen. 🛠️ (📖 p. 129)	○	●	●	●
Check the fuel pressure. 🛠️		●	●	●
Check the headlight setting. (📖 p. 115)	○	●	●	●
Check the idle speed. 🛠️		●	●	●
Final check: Check the vehicle for operating safety and take a test ride. 🛠️	○	○	●	●
Read out the fault memory after the test ride using the Husqvarna Motorcycles diagnostics tool. 🛠️	○	○	●	●
Final steps				
Make a service entry in Husqvarna Motorcycles Dealer.net . 🛠️	○	○	●	●

- One-time interval
- Periodic interval

10.3 Recommended work

	Every 40 operating hours when used for motorsports			
	Every 10 operating hours when used for motorsports			
	every 48 months			
	every 12 months			
	Every 80 operating hours			
	Every 40 operating hours			
	After 20 operating hours			
	After 10 operating hours			
Change the front brake fluid. 🛠️			●	●
Change the rear brake fluid. 🛠️			●	●
Change the hydraulic clutch fluid. 🛠️ (📖 p. 85)			●	●
Lubricate the steering head bearing. 🛠️ (📖 p. 63)			●	●
Clean the pressure sensor hose.		●	●	●
Service the fork. 🛠️	○			
Perform the shock absorber service. 🛠️		○		
Check the electric starter drive. 🛠️		●	●	
Change the fuel filter. 🛠️		●		●

10 SERVICE SCHEDULE

	Every 40 operating hours when used for motorsports	Every 10 operating hours when used for motorsports	every 48 months	every 12 months	Every 80 operating hours	Every 40 operating hours	After 20 operating hours	After 10 operating hours
Change the piston and check the cylinder. 🛠️			•	•				•
Change the oil pump; clean the oil screen. 🛠️				•				
Clean the oil screen in the oil tank. 🛠️ (📖 p. 132)				•				
Clean the protection cap of the pressure sensor. 🛠️				•	•			•
Change the coolant. 🛠️ (📖 p. 122)								•
Perform minor engine service. (Check the exhaust control for functioning and smooth operation. Check the clutch.) 🛠️			•	•				•
Perform major engine service including removing and installing the engine. (Change the connecting rod, conrod bearing, and crank pin. Clean the hose connections of the pressure sensor. Check the transmission and the shift mechanism. Change all engine bearings.) 🛠️					•			•

- One-time interval
- Periodic interval

11.1 Checking the basic chassis setting with rider's weight

i Info

When adjusting the basic chassis setting, first adjust the shock absorber and then the fork.

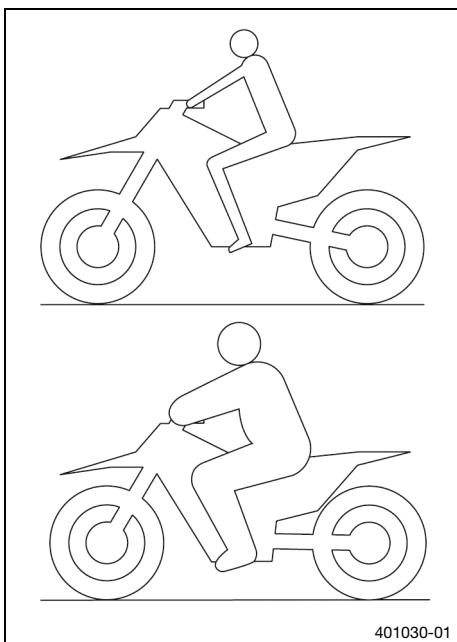

- For optimal motorcycle riding characteristics and to avoid damage to forks, shock absorbers, link fork and frame, the basic settings of the suspension components must match the rider's weight.
- As delivered, Husqvarna motorcycles are adjusted for an average rider's weight (with full protective clothing).

Guideline

Standard rider weight	75 ... 85 kg (165 ... 187 lb.)
-----------------------	--------------------------------

- If the rider's weight is above or below this range, the basic setting of the suspension components must be adjusted accordingly.
- Small weight differences can be compensated by adjusting the spring preload, but in the case of large weight differences, the springs must be replaced.



11.2 Compression damping of the shock absorber

The compression damping of the shock absorber is divided into two ranges: high-speed and low-speed. High-speed and low-speed refer to the compression speed of the rear wheel suspension and not to the vehicle speed.

The high-speed compression adjuster has an effect, for example, when landing after a jump: the rear wheel suspension compresses quickly.

The low-speed compression adjuster has an effect, for example, when riding over long ground swells: the rear wheel suspension compresses slowly.

These two ranges can be adjusted separately, although the transition between high-speed and low-speed is gradual. Thus, modifications in the high-speed range affect the compression damping in the low-speed range and vice versa.

11.3 Adjusting the low-speed compression damping of the shock absorber



Caution

Risk of injury Parts of the shock absorber will move around if the shock absorber is detached incorrectly.

The shock absorber is filled with highly compressed nitrogen.

- Please follow the description provided. (Your authorized Husqvarna Motorcycles workshop will be glad to help.)

i Info

The effect of the low-speed compression adjuster can be seen in slow to normal compression of the shock absorber.

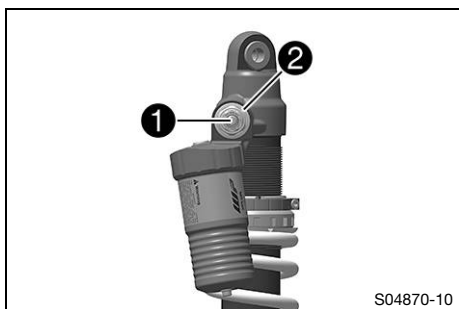

- Turn adjusting screw ① clockwise with a screwdriver as far as the last perceptible click.

i Info
Do not loosen fitting ②!

- Turn counterclockwise by the number of clicks corresponding to the shock absorber type.

Guideline

Lowspeed compression damping	
Comfort	17 clicks
Standard	15 clicks
Sport	13 clicks

i Info
Turn clockwise to increase damping; turn counterclockwise to reduce damping.

11.4 Adjusting the high-speed compression damping of the shock absorber



Caution

Risk of injury Parts of the shock absorber will move around if the shock absorber is detached incorrectly.

The shock absorber is filled with highly compressed nitrogen.

- Please follow the description provided. (Your authorized Husqvarna Motorcycles workshop will be glad to help.)



Info

The effect of the high speed compression adjuster can be seen in the fast compression of the shock absorber.

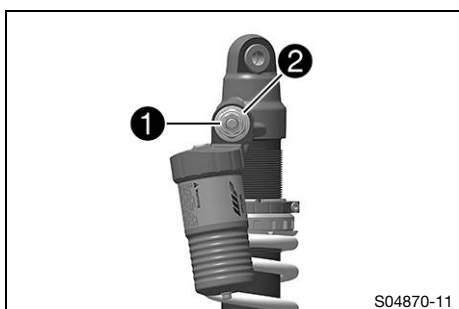

- Using an open end wrench, turn adjusting screw ① clockwise all the way.

i Info
Do not loosen fitting ②!

- Turn counterclockwise by the number of turns corresponding to the shock absorber type.

Guideline

Hightspeed compression damping	
Comfort	2.5 turns
Standard	2 turns
Sport	1.5 turns

i Info
Turn clockwise to increase damping; turn counterclockwise to reduce damping.

11.5 Adjusting the rebound damping of the shock absorber



Caution

Risk of injury Parts of the shock absorber will move around if the shock absorber is detached incorrectly.

The shock absorber is filled with highly compressed nitrogen.

- Please follow the description provided. (Your authorized Husqvarna Motorcycles workshop will be glad to help.)

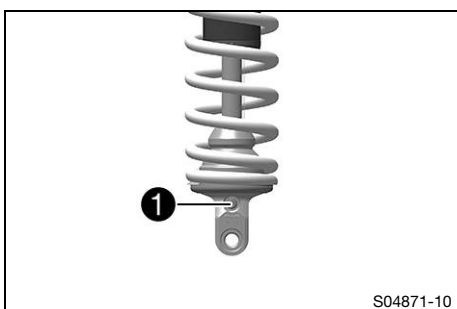

- Turn adjusting screw **1** clockwise up to the last perceptible click.
- Turn counterclockwise by the number of clicks corresponding to the shock absorber type.

Guideline

Rebound damping	
Comfort	17 clicks
Standard	15 clicks
Sport	13 clicks



Info

Turn clockwise to increase the damping; turn counterclockwise to reduce damping when the shock absorber rebounds.

11.6 Measuring the dimension of the rear wheel unloaded

Preparatory work

- Raise the motorcycle with a lift stand. (📖 p. 56)

Main work

- Position the sag gage in the rear axle and measure the distance to marking **SAG** on the rear fender.

Sag gauge (00029090500)
Pin, sag scale (00029990010)

- Note the value as dimension **A**.

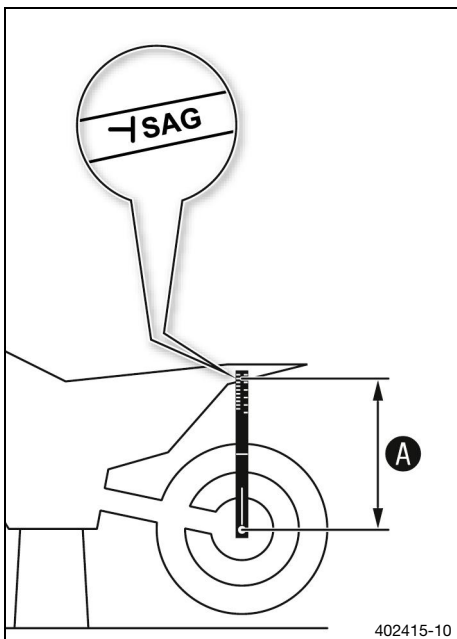

Finishing work

- Remove the motorcycle from the lift stand. (📖 p. 56)

11.7 Checking the static sag of the shock absorber

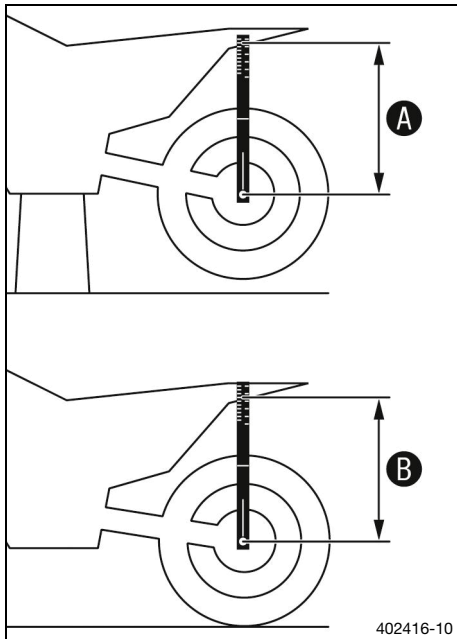

- Measure dimension **A** of rear wheel unloaded. (📖 p. 49)
- Hold the motorcycle upright with aid of an assistant.
- Measure the distance again between the rear axle and marking **SAG** on the rear fender using the sag gage.
- Note the value as dimension **B**.

i Info

The static sag is the difference between measurements **A** and **B**.

- Check the static sag.

Static sag	37 mm (1.46 in)
------------	-----------------

- » If the static sag is less or more than the specified value:
 - Adjust the spring preload of the shock absorber. (🔧 p. 51)

11.8 Checking the riding sag of the shock absorber

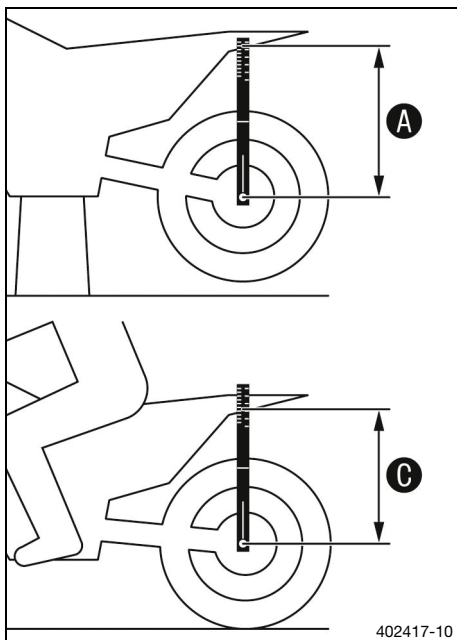

- Measure dimension **A** of rear wheel unloaded. (📖 p. 49)
- With another person holding the motorcycle, the rider, wearing full protective clothing, sits on the seat in a normal sitting position (feet on footrests) and bounces up and down a few times.
 - ✓ The rear wheel suspension levels out.
- Another person again measures the distance between the rear axle and marking **SAG** on the rear fender using the sag gage.
- Note the value as dimension **C**.

i Info

The riding sag is the difference between measurements **A** and **C**.

- Check riding sag.

Guideline

Riding sag	110 mm (4.33 in)
------------	------------------

- » If the riding sag differs from the specified measurement:
 - Adjust the riding sag. (🔧 p. 52)

11.9 Adjusting the spring preload of the shock absorber ↩



Caution

Risk of injury Parts of the shock absorber will move around if the shock absorber is detached incorrectly.

The shock absorber is filled with highly compressed nitrogen.

- Please follow the description provided. (Your authorized Husqvarna Motorcycles workshop will be glad to help.)



Info

Before changing the spring preload, make a note of the present setting, e.g., by measuring the spring length.

Preparatory work

- Raise the motorcycle with a lift stand. (📖 p. 56)
- Remove the shock absorber. ↩ (📖 p. 65)
- After removing the shock absorber, clean it thoroughly.

Main work

- Loosen screw ❶.
- Turn adjusting ring ❷ until the spring is no longer under tension.

Hook wrench (90129051000)

- Measure the total spring length while the spring is not under tension.

Info

If the spring cannot be fully released, the spring must be removed to accurately measure the spring length.

- Tension the spring by turning adjusting ring ❷ to specified dimension A.

Guideline

Spring preload	10 mm (0.39 in)
----------------	-----------------

Info

Depending on the static sag and/or the riding sag, it may be necessary to increase or decrease the spring preload.

- Tighten screw ❶.

Guideline

Screw, shock absorber adjusting ring	M5	5 Nm (3.7 lbf ft)
--------------------------------------	----	-------------------

Finishing work

- Install the shock absorber. ↩ (📖 p. 66)
- Remove the motorcycle from the lift stand. (📖 p. 56)

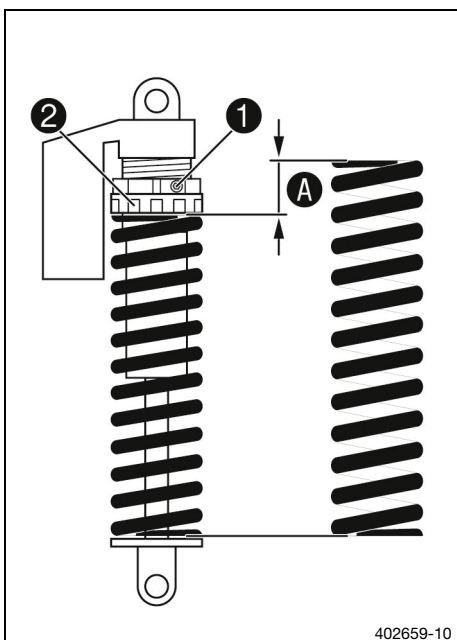

11.10 Adjusting the riding sag 🛠️

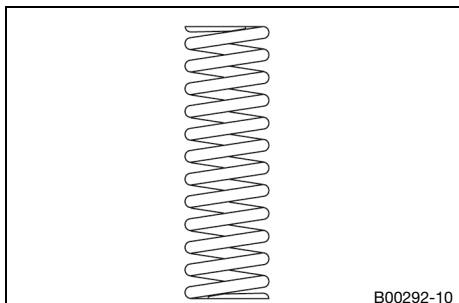

Preparatory work

- Raise the motorcycle with a lift stand. (📖 p. 56)
- Remove the shock absorber. 🛠️ (📖 p. 65)
- After removing the shock absorber, clean it thoroughly.

Main work

- Choose and mount a suitable spring.

Guideline

Spring rate	
Weight of rider: 65 ... 75 kg (143 ... 165 lb.)	36 N/mm (206 lb/in)
Weight of rider: 75 ... 85 kg (165 ... 187 lb.)	39 N/mm (223 lb/in)
Weight of rider: 85 ... 95 kg (187 ... 209 lb.)	42 N/mm (240 lb/in)

i Info

The spring rate is shown on the outside of the spring.

Finishing work

- Install the shock absorber. 🛠️ (📖 p. 66)
- Remove the motorcycle from the lift stand. (📖 p. 56)
- Check the static sag of the shock absorber. (📖 p. 50)
- Check the riding sag of the shock absorber. (📖 p. 50)
- Adjust the rebound damping of the shock absorber. (📖 p. 49)

11.11 Checking the basic setting of the fork

i Info

For various reasons, no exact riding sag can be determined for the fork.

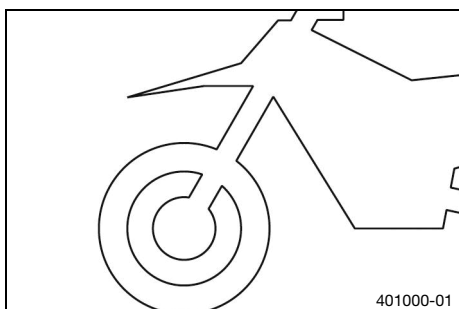

- As with the shock absorber, smaller differences in the rider's weight can be compensated by the spring preload.
- However, if the fork frequently bottoms out (hard end stop on compression), harder springs must be fitted to avoid damage to the fork and frame.
- If the fork feels unusually hard after extended periods of operation, the fork legs need to be bled.

11.12 Adjusting the compression damping of the fork

i Info

The hydraulic compression damping determines the fork suspension behavior.

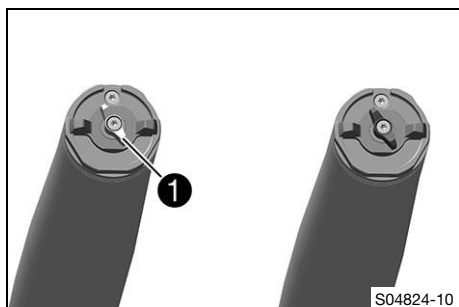

- Turn white adjuster **1** clockwise as far as it will go.

i Info

Adjuster **1** is located at the upper end of the left fork leg.

The compression damping is located in left fork leg **COMP** (white adjuster). The rebound damping is located in right fork leg **REB** (red adjuster).

- Turn counterclockwise by the number of clicks corresponding to the fork type.

Guideline

Compression damping	
Comfort	18 clicks
Standard	15 clicks
Sport	12 clicks

i Info

Turn clockwise to increase damping; turn counterclockwise to reduce damping during compression.



11.13 Adjusting the rebound damping of the fork

i Info

The hydraulic rebound damping determines the fork suspension behavior.

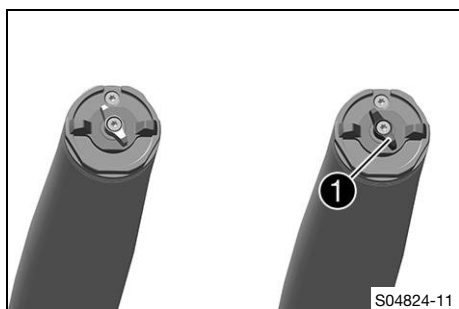

- Turn red adjuster **1** clockwise as far as it will go.

i Info

Adjuster **1** is located at the upper end of the right fork leg.

The compression damping is located in left fork leg **COMP** (white adjuster). The rebound damping is located in right fork leg **REB** (red adjuster).

- Turn counterclockwise by the number of clicks corresponding to the fork type.

Guideline

Rebound damping	
Comfort	18 clicks
Standard	15 clicks
Sport	12 clicks



Info

Turn clockwise to increase the damping; turn counterclockwise to reduce damping when the shock absorber rebounds.

11.14 Adjusting the spring preload of the fork

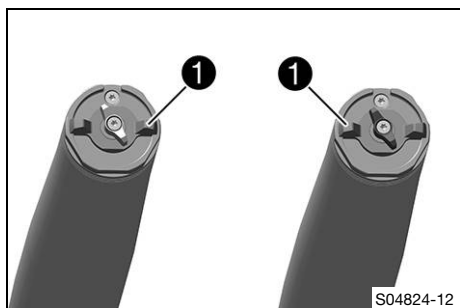

Preparatory work

- Raise the motorcycle with a lift stand. (📖 p. 56)

Main work

- Turn T-grips **1** counterclockwise all the way.
- ✓ Marking **+0** aligns with the right T-grip on both fork legs.



Info

Make the adjustment by hand only. Do not use a tool. Make the same adjustment on both fork legs.

- Turn the T-grips clockwise.

Guideline

Spring preload – preload adjuster	
Comfort	+0
Standard	+0
Sport	+3

- ✓ The T-grips engage noticeably at the numerical values.



Info

Adjust the spring preload to the numerical values only as the preload will not engage between the numerical values.

Turn clockwise to increase the spring preload; turn counterclockwise to reduce the spring preload.

Adjusting the spring preload has no influence on the absorption setting of the rebound.

Basically, however, you should set the rebound damping higher with a higher spring preload.

Finishing work

- Remove the motorcycle from the lift stand. (📖 p. 56)

11.15 Handlebar position

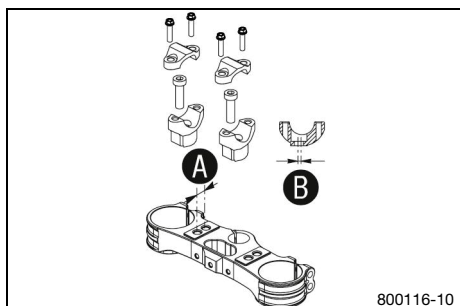

On the upper triple clamp, there are 2 holes at a distance of **A** to each other.

Hole distance A	15 mm (0.59 in)
-----------------	-----------------

The holes on the handlebar support are placed at a distance of **B** from the center.

Hole distance B	3.5 mm (0.138 in)
-----------------	-------------------

The handlebar can be mounted in four different positions. This allows the handlebar to be mounted in the most comfortable position for the rider.

11.16 Adjusting the handlebar position ↩



Warning

Danger of accidents A repaired handlebar poses a safety risk.

If the handlebar is bent or straightened, the material becomes fatigued. The handlebar may break as a result.

- Change the handlebar if the handlebar is damaged or bent.

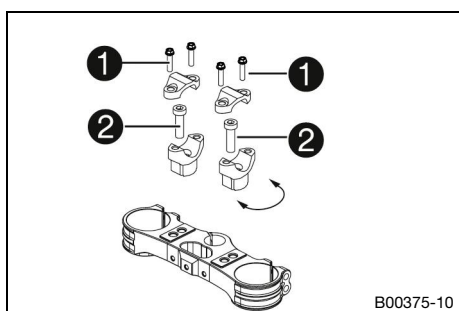

- Remove screws **1**. Take off the handlebar clamps. Remove the handlebar and lay it to one side.



Info

Cover the components to protect them against damage.

Do not kink the cables and lines.

- Remove screws **2**. Take off the handlebar supports.
- Place the handlebar supports in the required position. Mount and tighten screws **2**.

Guideline

Screw, handlebar support	M10	40 Nm (29.5 lbf ft) Loctite®243™
--------------------------	-----	--



Info

Position the left and right handlebar supports evenly.

- Position the handlebar.



Info

Make sure the cables and wiring are positioned correctly.

- Position the handlebar clamps. Mount screws **1** and tighten evenly.

Guideline

Screw, handlebar clamp	M8	20 Nm (14.8 lbf ft)
------------------------	----	---------------------



Info

Make sure the gap widths are even.

12.1 Raising the motorcycle with a lift stand

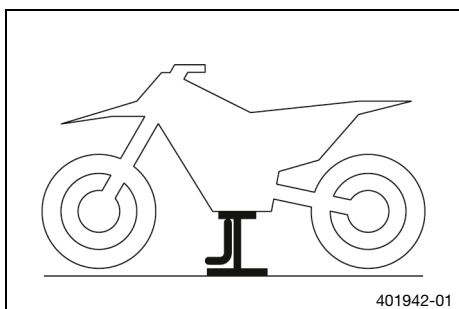

Note

Danger of damage The parked vehicle can roll away or fall over.

- Park the vehicle on a firm and level surface.
- Raise the motorcycle at the frame underneath the engine.

Lift stand (81329955100)

- ✓ Neither wheel is in contact with the ground.
- Secure the motorcycle against falling over.

12.2 Removing the motorcycle from the lift stand

Note

Danger of damage The parked vehicle can roll away or fall over.

- Park the vehicle on a firm and level surface.

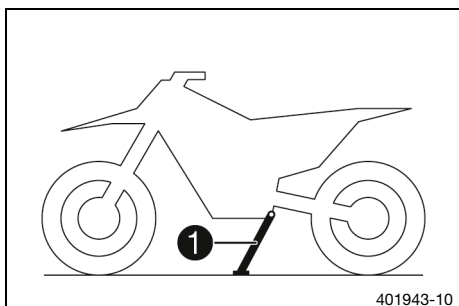

- Remove the motorcycle from the lift stand.
- Remove the lift stand.
- To park the motorcycle, press side stand ① to the ground with your foot and lean the motorcycle on it.

Info

When you are riding, the side stand must be folded up and secured with the rubber strap.

12.3 Bleeding the fork legs

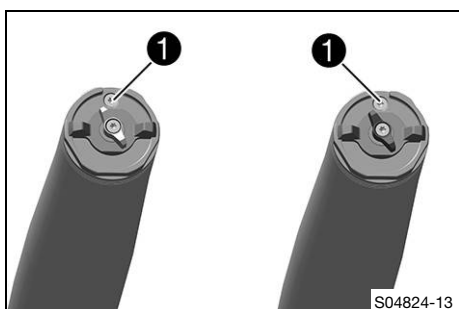

Preparatory work

- Raise the motorcycle with a lift stand. (📖 p. 56)

Main work

- Release bleeder screws ①.
- ✓ Any excess pressure escapes from the interior of the fork.
- Tighten the bleeder screws.

Finishing work

- Remove the motorcycle from the lift stand. (📖 p. 56)

12.4 Cleaning the dust boots of the fork legs

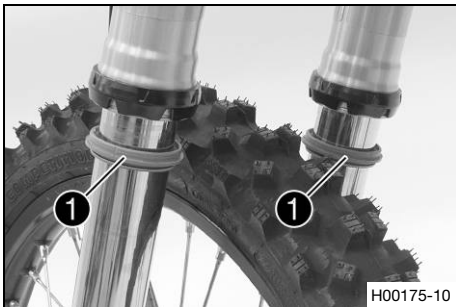

Preparatory work

- Raise the motorcycle with a lift stand. (📖 p. 56)
- Remove the fork protector. (📖 p. 59)

Main work

- Push dust boots ❶ of both fork legs downward.



Info

The dust boots remove dust and coarse dirt particles from the inside fork tubes. Over time, dirt can accumulate behind the dust boots. If this dirt is not removed, the oil seals behind can start to leak.



Warning

Danger of accidents Oil or grease on the brake discs reduces the braking effect.

- Always keep the brake discs free of oil and grease.
- Clean the brake discs with brake cleaner when necessary.

- Clean and oil the dust boots and inner fork tubes of both fork legs.

Universal oil spray (📖 p. 158)

- Press the dust boots back into their installation position.
- Remove excess oil.

Finishing work

- Install the fork protector. (📖 p. 59)
- Remove the motorcycle from the lift stand. (📖 p. 56)



12.5 Removing the fork legs 🗑️

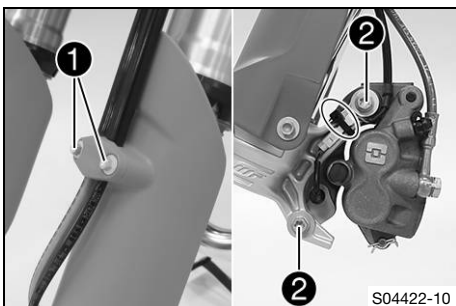

Preparatory work

- Remove the headlight mask with the headlight. (📖 p. 112)
- Raise the motorcycle with a lift stand. (📖 p. 56)
- Remove the front wheel. 🗑️ (📖 p. 98)

Main work

- Remove screws ❶ and take off the clamp.
- Remove the cable tie.
- Remove screws ❷ and take off the brake caliper.
- Allow the brake caliper and brake line to hang loosely to the side.



Info

Do not actuate the hand brake lever when the front wheel is removed.

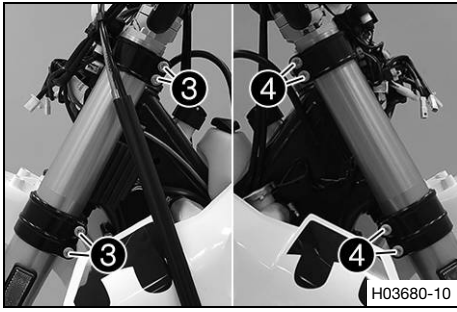

- Loosen screws **3**. Remove the left fork leg.
- Loosen screws **4**. Remove the right fork leg.

12.6 Installing the fork legs

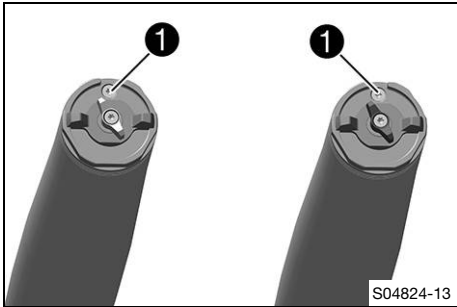

Main work

- Position the fork legs.
- ✓ Bleeder screws **1** are positioned toward the front.

Info

The compression damping is located in left fork leg **COMP** (white adjuster). The rebound damping is located in right fork leg **REB** (red adjuster). Grooves are milled into the side of the upper end of the fork legs. The second milled groove (from the top) must be flush with the upper edge of the upper triple clamp.

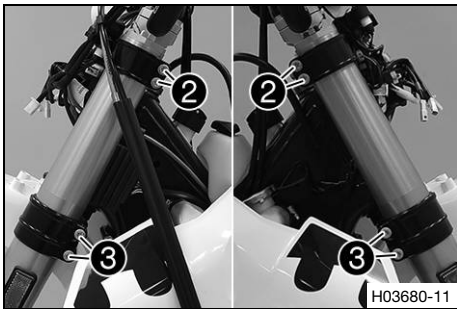

- Tighten screws **2**.

Guideline

Screw, top triple clamp	M8	17 Nm (12.5 lbf ft)
-------------------------	----	---------------------

- Tighten screws **3**.

Guideline

Screw, bottom triple clamp	M8	15 Nm (11.1 lbf ft)
----------------------------	----	---------------------

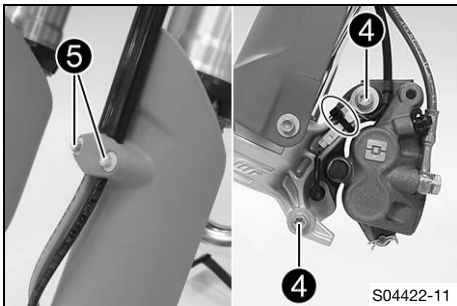

- Position the brake caliper, and mount and tighten screws **4**.

Guideline

Screw, front brake caliper	M8	25 Nm (18.4 lbf ft) Loctite® 243™
----------------------------	----	---

- Mount the cable ties.
- Position the brake line, the wiring harness, and the clamp. Mount and tighten screws **5**.

Finishing work

- Install the front wheel. (🔧 p. 99)
- Install the headlight mask with the headlight. (🔧 p. 112)
- Check the headlight setting. (🔧 p. 115)

12.7 Removing the fork protector

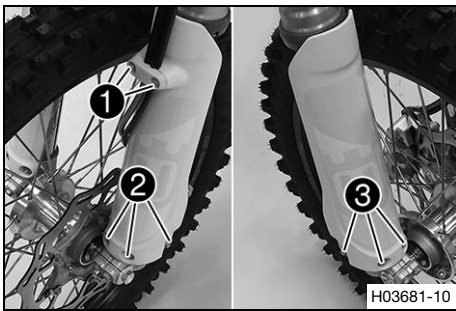

- Remove screws ① and take off the clamp.
- Remove screws ② and take off the left fork protector.
- Remove screws ③ and take off the right fork protector.

12.8 Installing the fork protector

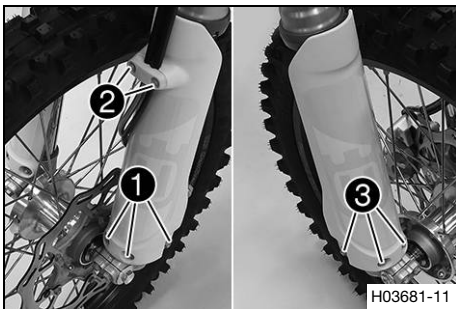

- Position the fork protector on the left fork leg. Mount and tighten screws ①.

Guideline

Remaining screws, chassis	M6	10 Nm (7.4 lbf ft)
---------------------------	----	--------------------

- Position the brake line, wiring harness, and clamp. Mount and tighten screws ②.
- Position the fork protector on the right fork leg. Mount and tighten screws ③.

Guideline

Remaining screws, chassis	M6	10 Nm (7.4 lbf ft)
---------------------------	----	--------------------

12.9 Removing the lower triple clamp

Preparatory work

- Remove the headlight mask with the headlight. (📖 p. 112)
- Raise the motorcycle with a lift stand. (📖 p. 56)
- Remove the front wheel. 🛠️ (📖 p. 98)
- Remove the fork legs. 🛠️ (📖 p. 57)
- Remove front fender. (📖 p. 63)

Main work

- Remove screw ①.
- Remove screw ②.
- Open cable holder ③ in front of the left radiator and detach the clutch line.
- Take off the upper triple clamp with the handlebar and set aside.

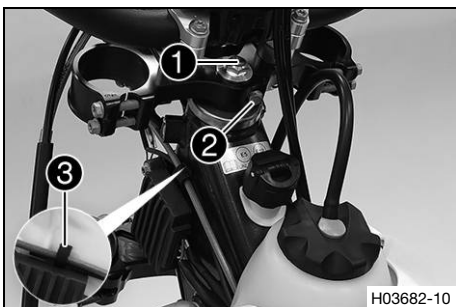

Info

Cover the components to protect them against damage.
Do not kink the cables and lines.

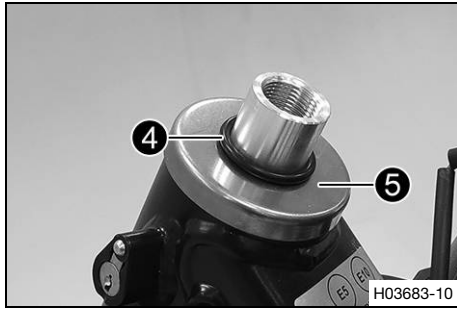

- Remove O-ring ④. Remove protective ring ⑤.
- Remove the lower triple clamp with the steering stem.
- Remove the upper steering head bearing.

12.10 Installing the lower triple clamp

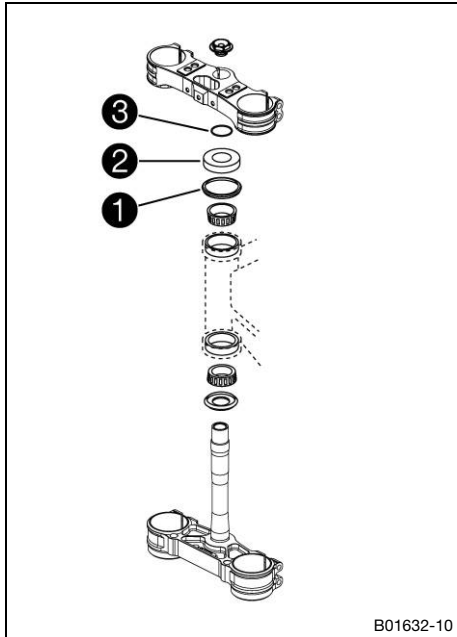

Main work

- Clean the bearing and sealing elements, check for damage, and grease.

High viscosity grease (📖 p. 157)

- Insert the lower triple clamp with the steering stem. Mount upper steering head bearing.
- Check whether upper steering head seal ① is correctly positioned.
- Mount protective ring ② and O-ring ③.



- Position the upper triple clamp with the handlebar.
- Mount screw ④, but do not tighten yet.
- Mount the clutch line with cable holder ⑤.

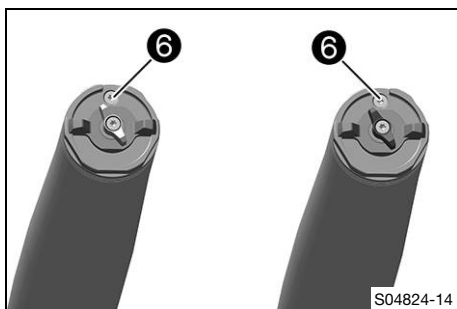

- Position the fork legs.
- ✓ Bleeder screws ⑥ are positioned toward the front.

Info

The compression damping is located in left fork leg **COMP** (white adjuster). The rebound damping is located in right fork leg **REB** (red adjuster). Grooves are milled into the side of the upper end of the fork legs. The second milled groove (from the top) must be flush with the upper edge of the upper triple clamp.

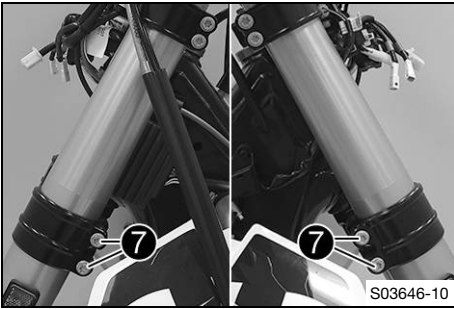

- Tighten screws **7**.

Guideline

Screw, bottom triple clamp	M8	15 Nm (11.1 lbf ft)
----------------------------	----	---------------------

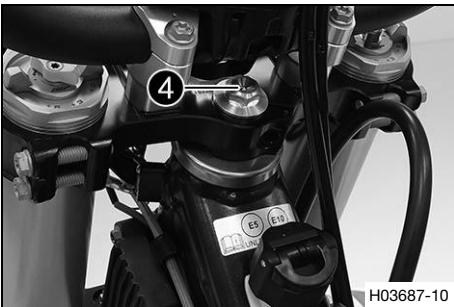

- Tighten screw **4**.

Guideline

Screw, top steering head	M20x1.5	12 Nm (8.9 lbf ft)
--------------------------	---------	--------------------

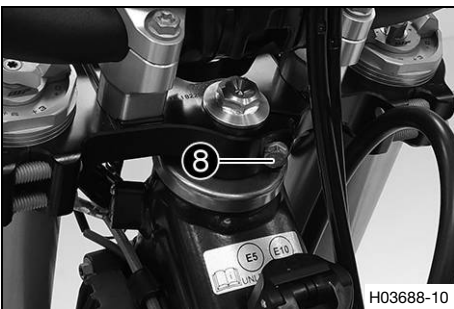

- Mount and tighten screw **8**.

Guideline

Screw, top steering stem	M8	17 Nm (12.5 lbf ft) Loctite®243™
--------------------------	----	--

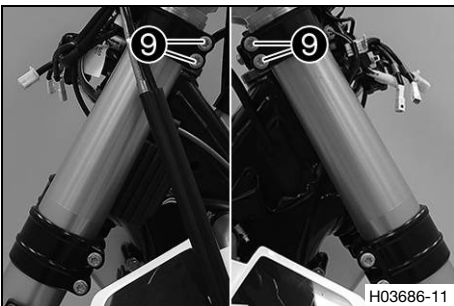

- Using a plastic hammer, tap lightly on the upper triple clamp to avoid stresses.

- Tighten screws **9**.

Guideline

Screw, top triple clamp	M8	17 Nm (12.5 lbf ft)
-------------------------	----	---------------------

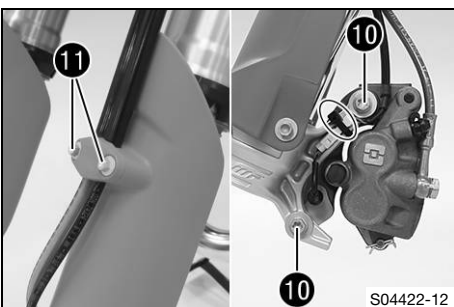

- Position the brake caliper, and mount and tighten screws **10**.

Guideline

Screw, front brake caliper	M8	25 Nm (18.4 lbf ft) Loctite®243™
----------------------------	----	--

- Mount the cable ties.
- Position the brake line, the wiring harness, and the clamp. Mount and tighten screws **11**.

Finishing work

- Install front fender. (📖 p. 64)
- Install the front wheel. 🛠️ (📖 p. 99)
- Install the headlight mask with the headlight. (📖 p. 112)

- Check that the wiring harness, throttle cables, and brake and clutch lines can move freely and are routed correctly.
- Check the steering head bearing for play. (📖 p. 62)
- Remove the motorcycle from the lift stand. (📖 p. 56)
- Check the headlight setting. (📖 p. 115)

12.11 Checking the steering head bearing play



Warning

Danger of accidents Incorrect steering head bearing play impairs the handling characteristic and damages components.

- Correct incorrect steering head bearing play immediately. (Your authorized Husqvarna Motorcycles workshop will be glad to help.)



Info

If the vehicle is operated for a lengthy period with play in the steering head bearing, the bearings and the bearing seats in the frame can become damaged over time.

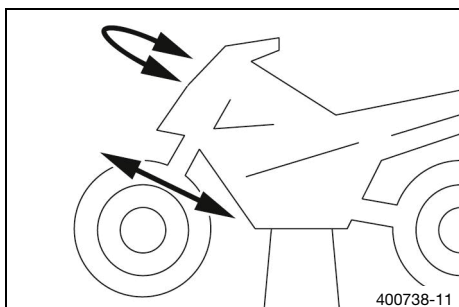

Preparatory work

- Raise the motorcycle with a lift stand. (📖 p. 56)

Main work

- Move the handlebar to the straight-ahead position. Move the fork legs to and fro in the direction of travel.

Play should not be detectable on the steering head bearing.

» If there is detectable play:

- Adjust steering head bearing play. (🔧📖 p. 63)

- Move the handlebar to and fro over the entire steering range.

It must be possible to move the handlebar easily over the entire steering range. There should be no detectable detent positions.

» If detent positions are detected:

- Adjust steering head bearing play. (🔧📖 p. 63)

- Check the steering head bearing and change if necessary.

- Check the steering stop bolts for correct adjustment and locking.

Finishing work

- Remove the motorcycle from the lift stand. (📖 p. 56)

12.12 Adjusting steering head bearing play

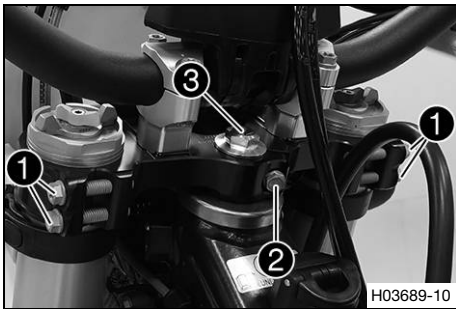

Preparatory work

- Raise the motorcycle with a lift stand. (p. 56)

Main work

- Loosen screws 1. Remove screw 2.
- Loosen and retighten screw 3.

Guideline

Screw, top steering head	M20x1.5	12 Nm (8.9 lbf ft)
--------------------------	---------	--------------------

- Using a plastic hammer, tap lightly on the upper triple clamp to avoid stresses.

- Tighten screws 1.

Guideline

Screw, top triple clamp	M8	17 Nm (12.5 lbf ft)
-------------------------	----	---------------------

- Mount and tighten screw 2.

Guideline

Screw, top steering stem	M8	17 Nm (12.5 lbf ft) Loctite®243™
--------------------------	----	--

Finishing work

- Check the steering head bearing for play. (p. 62)
- Remove the motorcycle from the lift stand. (p. 56)



12.13 Lubricating the steering head bearing

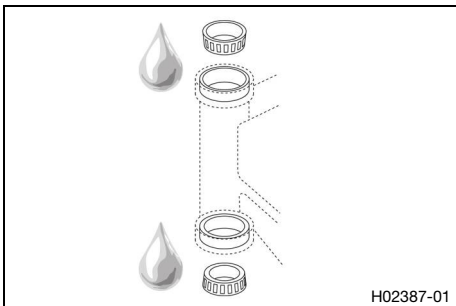

- Remove the lower triple clamp. (p. 59)
- Install the lower triple clamp. (p. 60)



Info

The steering head bearing is cleaned and lubricated in the course of removal and installation of the lower triple clamp.



12.14 Removing front fender

Preparatory work

- Remove the headlight mask with the headlight. (p. 112)

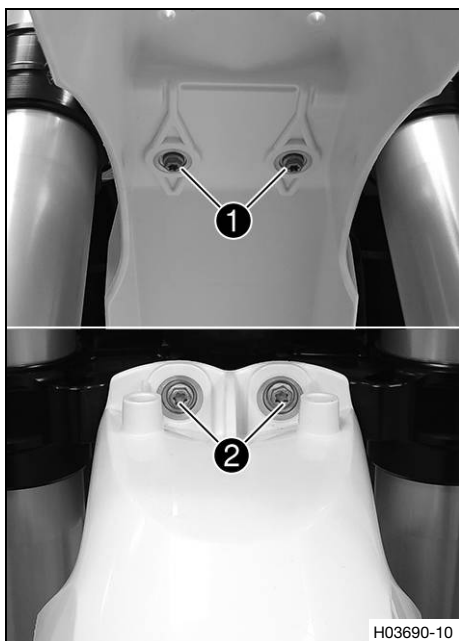

Main work

- Remove screws ❶.
- Remove screws ❷. Take off the front fender.

12.15 Installing front fender

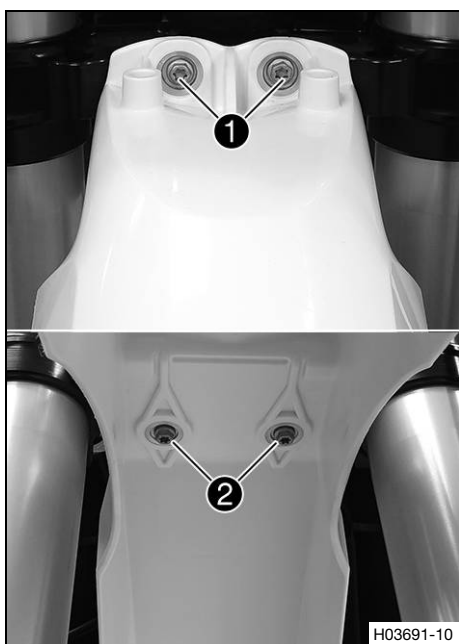

Main work

- Position front fender. Mount and tighten screws ❶ and ❷.

Guideline

Remaining screws, chassis	M6	10 Nm (7.4 lbf ft)
------------------------------	----	--------------------

Finishing work

- Install the headlight mask with the headlight. (📖 p. 112)
- Check the headlight setting. (📖 p. 115)

12.16 Removing the shock absorber

Preparatory work

- Raise the motorcycle with a lift stand. (📖 p. 56)

Main work

- Remove the cable ties.
- Remove screws **1** with the washers.
- Detach the frame protector in area **A** and take it off.

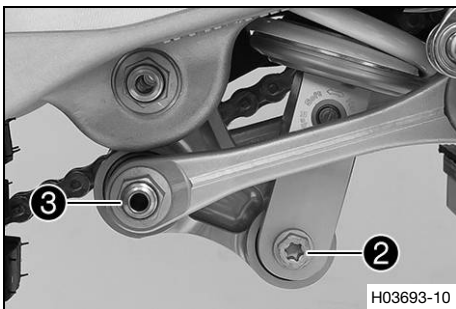
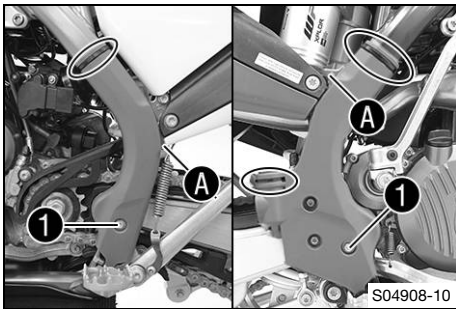

- Remove screw **2**.
- Remove fitting **3**.



Info

Raise the link fork slightly to be able to remove the screws more easily.

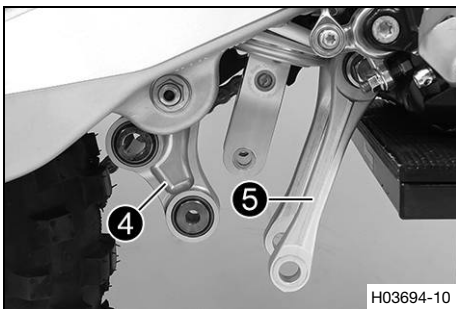

- Press angle lever **4** toward the rear.
- Press linkage lever **5** downward.

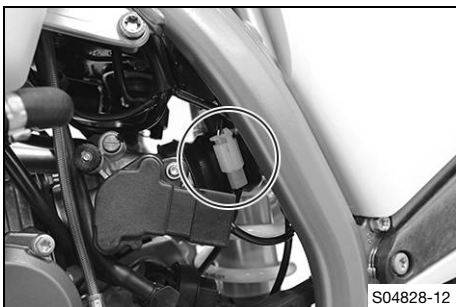

(TE 150i EU)

- Disconnect the plug-in connector of the brake light switch.

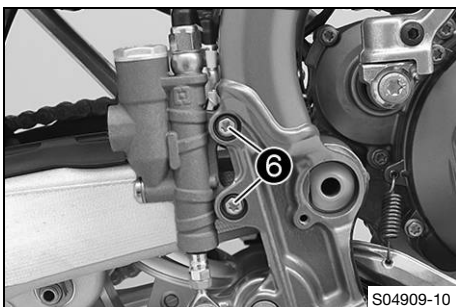

- Remove screws **6**.
- Pull off foot brake cylinder from the push rod.



- Remove the connecting link of the chain.



Info

Cover the components to protect them against damage.

- Take off the chain.

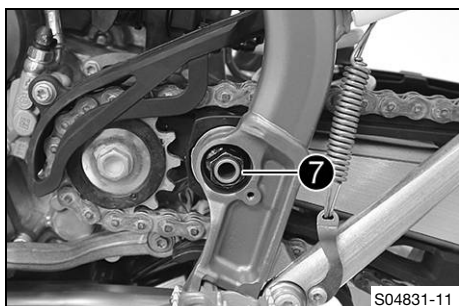

- Remove nut **7** and pull out the swingarm pivot.
- Push the link fork back and secure it against falling over.

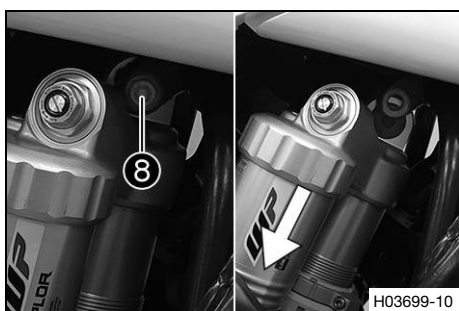

- Hold the shock absorber and remove screw **8**.
- Remove the shock absorber carefully at the bottom.

12.17 Installing the shock absorber ↩



Main work

- Carefully position the shock absorber into the vehicle from the bottom.
- Mount and tighten screw **1**.

Guideline

Screw, top shock absorber	M10	60 Nm (44.3 lbf ft) Loctite® 2701™
---------------------------	-----	--

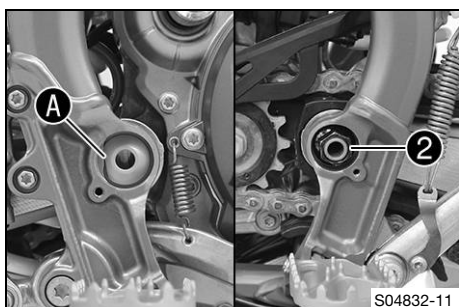

- Position the link fork and mount the swingarm pivot.



Info

Pay attention to flat area **A**.

- Mount and tighten nut **2**.

Guideline

Nut, swingarm pivot	M16x1.5	100 Nm (73.8 lbf ft)
---------------------	---------	----------------------

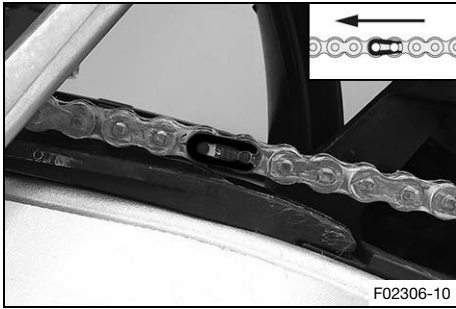

F02306-10

- Mount the chain.
- Connect the chain with the connecting link.

Guideline

The closed side of the chain joint lock must face in the direction of travel.

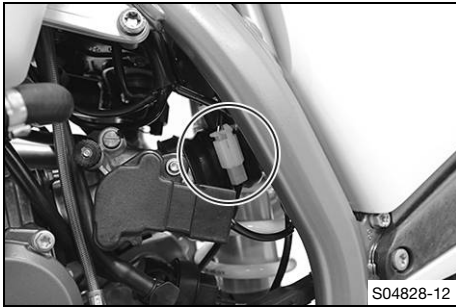

S04828-12

(TE 150i EU)

- Join plug-in connector of the brake light switch.

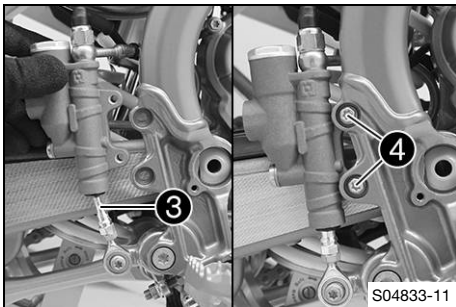

S04833-11

- Position the foot brake cylinder.
 - ✓ Push rod **3** engages in the foot brake cylinder.
 - ✓ The dust boot is correctly positioned.
- Mount and tighten screws **4**.

Guideline

Remaining screws, chassis	M6	10 Nm (7.4 lbf ft)
---------------------------	----	--------------------

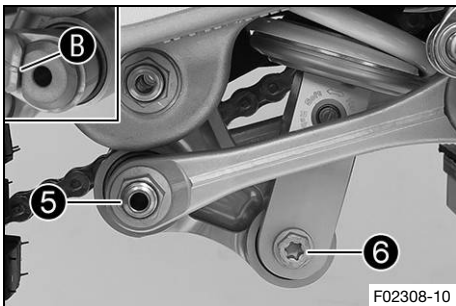

F02308-10

- Position the angle lever and linkage lever.
- Mount and tighten fitting **5**.

Guideline

Nut, linkage lever on angle lever	M14x1.5	60 Nm (44.3 lbf ft)
-----------------------------------	---------	---------------------

i Info
Pay attention to flat area **B**.

- Mount and tighten screw **6**.

Guideline

Screw, bottom shock absorber	M10	60 Nm (44.3 lbf ft) Loctite® 2701™
------------------------------	-----	--

i Info
Raise the link fork slightly to be able to mount the screw more easily.

12 SERVICE WORK ON THE CHASSIS

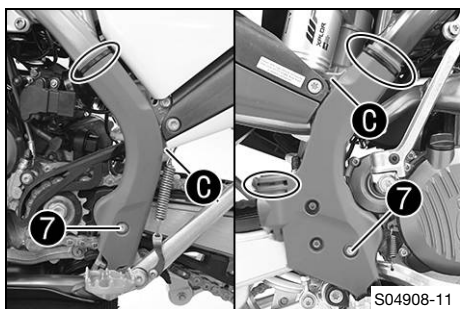

- Attach frame protector in area **C** and position it.
- Mount and tighten screws **7** with the washers.

Guideline

Screw, frame protector	M5	3 Nm (2.2 lbf ft)
------------------------	----	-------------------

- Mount the new cable ties.

Finishing work

- Remove the motorcycle from the lift stand. (📖 p. 56)

12.18 Removing the seat

Preparatory work

- Remove the air filter box cover. (📖 p. 69)

Main work

- Remove screw **1**.

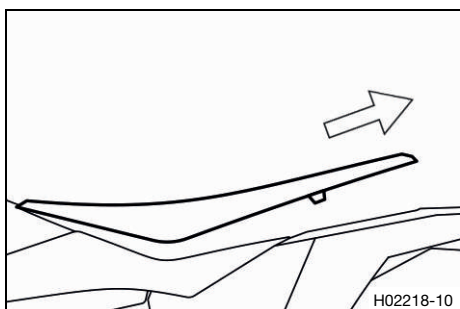

- Raise the rear of the seat, pull the seat back, and lift it off.

12.19 Mounting the seat

Main work

- Mount the front of the seat on the collar bushing of the fuel tank and the rear in the bracket.
- Push the seat forward.
- Make sure the seat is correctly latched in place.

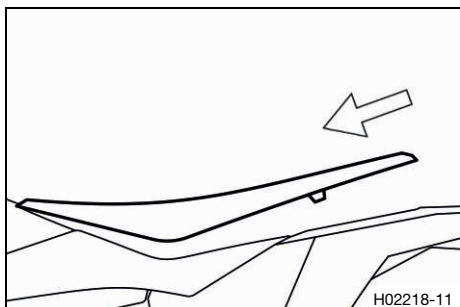

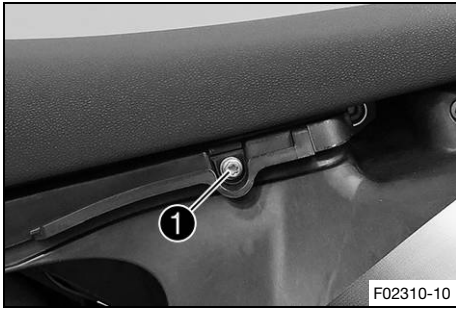

- Mount and tighten screw ①.

Guideline

Remaining screws, chassis	M6	10 Nm (7.4 lbf ft)
---------------------------	----	--------------------

Finishing work

- Install the air filter box cover. (📖 p. 69)

12.20 Removing the air filter box cover

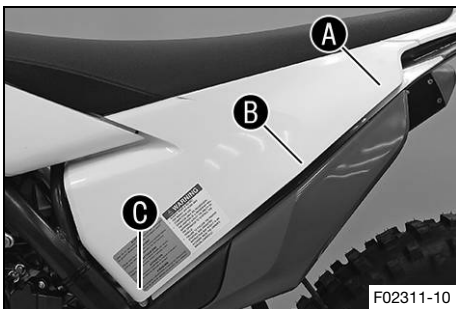

- Pull off the air filter box cover sideways in areas ①, ② and ③ and take off toward the rear.

12.21 Installing the air filter box cover

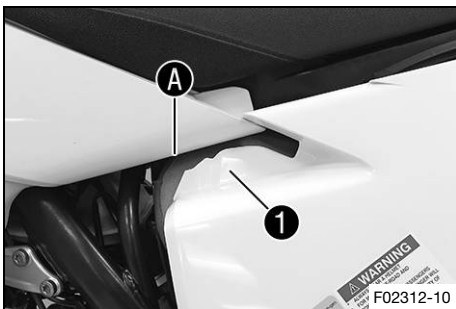

- Attach catch ① of the air filter box in area ① and push forward.

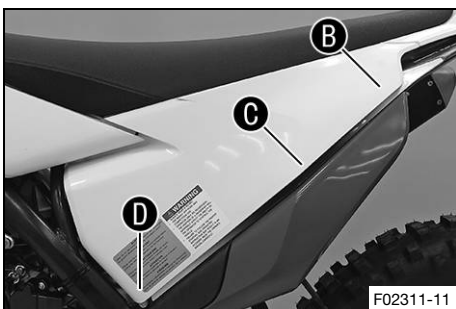

- Engage the air filter box cover in areas ②, ③ and ④.

12.22 Removing the air filter ↴

Note

Engine damage Unfiltered intake air has a negative effect on the service life of the engine. Dust and dirt will enter the engine without an air filter.

- Only operate the vehicle if it is equipped with an air filter.



Note

Environmental hazard Hazardous substances cause environmental damage.

- Dispose of oils, grease, filters, fuel, cleaning agents, brake fluid, etc., correctly and in compliance with the applicable regulations.

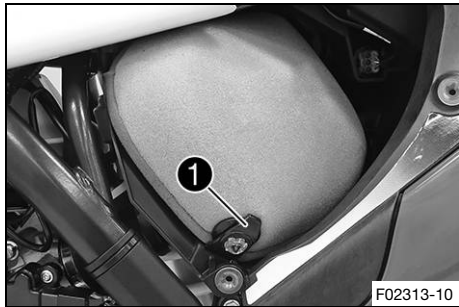

Preparatory work

- Remove the air filter box cover. (📖 p. 69)

Main work

- Detach retaining tab ❶. Remove air filter with air filter support.
- Remove air filter from air filter support.

12.23 Cleaning the air filter and air filter box ↴



Note

Environmental hazard Hazardous substances cause environmental damage.

- Dispose of oils, grease, filters, fuel, cleaning agents, brake fluid, etc., correctly and in compliance with the applicable regulations.



Info

Do not clean the air filter with fuel or petroleum since these substances attack the foam.

Preparatory work

- Remove the air filter box cover. (📖 p. 69)
- Remove the air filter. ↴ (📖 p. 70)

Main work

- Wash the air filter thoroughly in special cleaning liquid and allow it to dry properly.

Air filter cleaner (📖 p. 157)



Info

Only press the air filter to dry it, never wring it out.

- Oil the dry air filter with a high-grade air filter oil.

Oil for foam air filter (📖 p. 157)

- Clean the air filter box.

- Clean the intake flange and check it for damage and tightness.

Finishing work

- Install the air filter. (📖 p. 71)
- Install the air filter box cover. (📖 p. 69)



12.24 Installing the air filter 🗑️

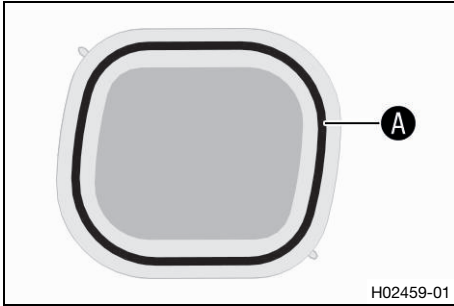

Main work

- Mount the clean air filter on the air filter support.
- Grease the air filter in area **A**.

Long-life grease (📖 p. 157)

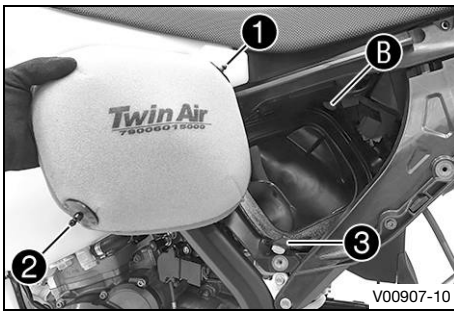

- Insert air filter and position retaining pin **1** in bushing **B**.
✓ The air filter is correctly positioned.
- Insert retaining tab **3**.
✓ Retaining pin **2** is secured with retaining tab **3**.



Info

If the air filter is not mounted correctly, dust and dirt may enter the engine and result in damage.

Finishing work

- Install the air filter box cover. (📖 p. 69)



12.25 Removing the main silencer



Warning

Danger of burns The exhaust system gets very hot when the vehicle is driven.

- Allow the exhaust system to cool down before performing any work on the vehicle.

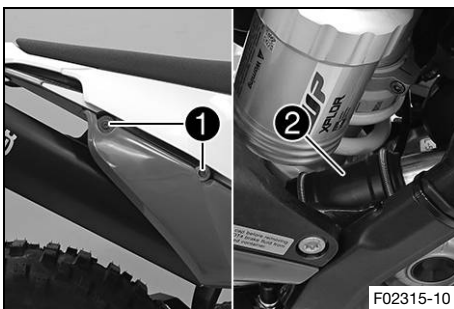

- Remove screws **1** with the washers.
- Pull off the main silencer with exhaust sleeve **2** and the spring ring from the manifold.



12.26 Installing the main silencer

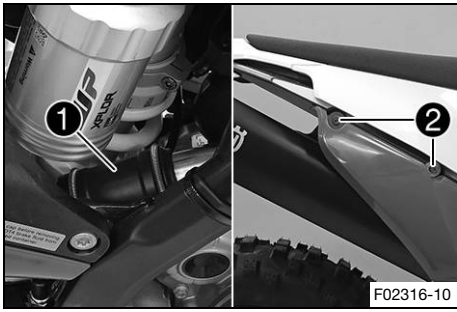

- Mount the main silencer with rubber sleeve **1** and the spring rings.
- Mount and tighten screws **2** with the washers.

Guideline

Remaining screws, chassis	M6	10 Nm (7.4 lbf ft)
---------------------------	----	--------------------

12.27 Changing the glass fiber yarn filling of the main silencer



Warning

Danger of burns The exhaust system gets very hot when the vehicle is driven.

- Allow the exhaust system to cool down before performing any work on the vehicle.



Info

Over time, the fibers of the glass fiber yarn filling escape and the damper "burns" out. Not only is the noise level higher, but the performance characteristics change.

Preparatory work

- Remove main silencer. (📖 p. 71)

Main work

- Remove screws **1**. Pull out inner tube **2** with O-ring **3**.
- Pull glass fiber yarn filling **4** from the inner tube.
- Clean the parts that need to be reinstalled and check for damage.
- Mount new glass fiber yarn filling **4** on the inner tube.
- Push outer tube **5** over the inner tube with the new glass fiber yarn filling and the O-ring.
- Mount and tighten all screws **1**.

Guideline

Screws on main silencer	M5	7 Nm (5.2 lbf ft)
-------------------------	----	-------------------

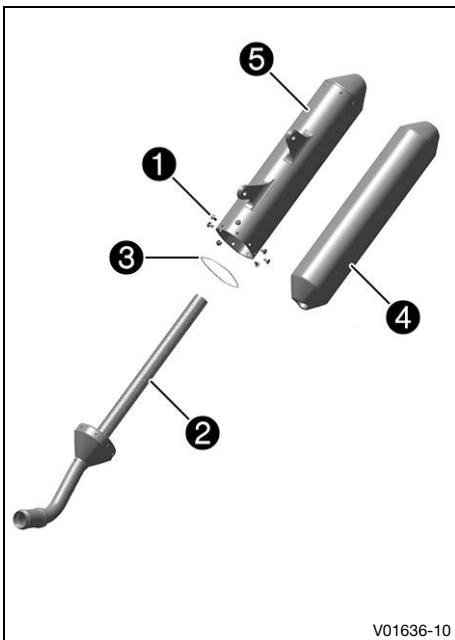

Finishing work

- Install the main silencer. (📖 p. 72)

12.28 Removing the right side cover

Preparatory work

- Remove the air filter box cover. (📖 p. 69)
- Remove the seat. (📖 p. 68)

Main work

- Detach side cover in area **A**, pull off sideways in area **B** and take off toward the rear.

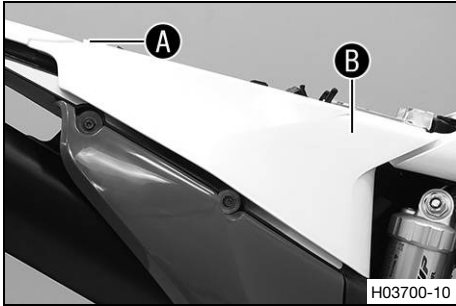

12.29 Installing the right side cover

Main work

- Attach side cover with the holding lugs **A** from below and push upward.
- Engage the side cover in areas **B** and **C**.

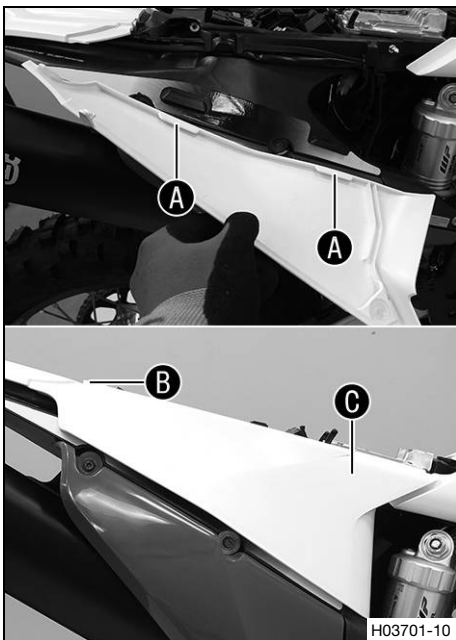

Finishing work

- Mount the seat. (📖 p. 68)
- Install the air filter box cover. (📖 p. 69)

12.30 Removing the fuel tank ↱



Danger

Fire hazard Fuel is highly flammable.

The fuel in the fuel tank expands when warm and can escape if overfilled.

- Do not fuel the vehicle in the vicinity of open flames or lit cigarettes.
- Switch off the engine for refueling.
- Make sure that no fuel is spilled; particularly not on hot parts of the vehicle.
- If any fuel is spilled, wipe it off immediately.
- Observe the specifications for refueling.



Warning

Danger of poisoning Fuel is poisonous and a health hazard.

- Avoid skin, eye and clothing contact with fuel.
- Immediately consult a doctor if you swallow fuel.
- Do not inhale fuel vapors.
- In case of skin contact, rinse the affected area with plenty of water.
- Rinse the eyes thoroughly with water, and consult a doctor in case of fuel contact with the eyes.
- Change your clothing in case of fuel spills on them.
- Keep fuels correctly in a suitable canister, and out of the reach of children.

Preparatory work

- Remove the air filter box cover. (📖 p. 69)
- Remove the seat. (📖 p. 68)
- Remove the right side cover. (📖 p. 73)

Main work

- Unplug connector ❶ of the fuel pump.
- Clean quick release coupling ❷ thoroughly with compressed air.

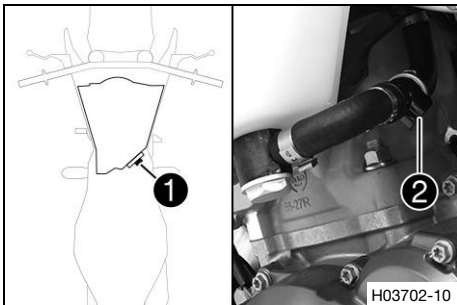

Info

Under no circumstances should dirt enter into the fuel line. Dirt in the fuel line clogs the injection valve!

- Disconnect the quick release coupling.



Info

Remaining fuel may flow out of the fuel hose.

- Mount wash cap set ❸.

Wash cap set (81212016100)

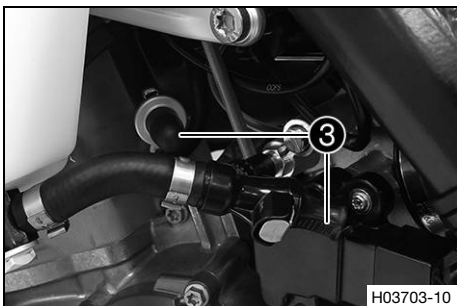

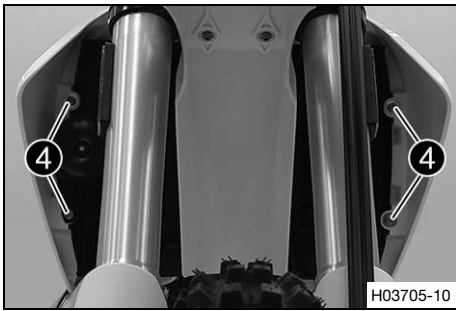

- Remove screws 4 with the collar bushings.
- (TE 150i EU)**
- Hang the horn and horn bracket to one side.

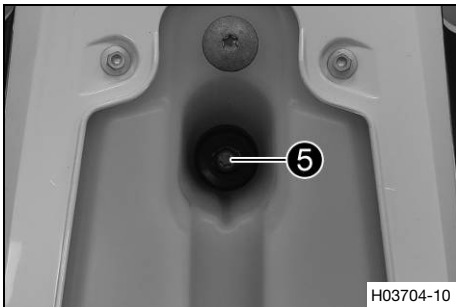

- Remove screw 5 with the rubber bushing.
- Pull the fuel tank breather hose off the fuel tank lid.

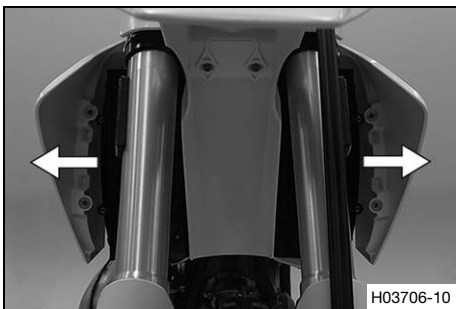

- Pull both spoilers laterally off the radiator and lift off the fuel tank.

12.31 Installing the fuel tank ↩



Danger

Fire hazard Fuel is highly flammable.

The fuel in the fuel tank expands when warm and can escape if overfilled.

- Do not fuel the vehicle in the vicinity of open flames or lit cigarettes.
- Switch off the engine for refueling.
- Make sure that no fuel is spilled; particularly not on hot parts of the vehicle.
- If any fuel is spilled, wipe it off immediately.
- Observe the specifications for refueling.



Warning

Danger of poisoning Fuel is poisonous and a health hazard.

- Avoid skin, eye and clothing contact with fuel.
- Immediately consult a doctor if you swallow fuel.
- Do not inhale fuel vapors.
- In case of skin contact, rinse the affected area with plenty of water.
- Rinse the eyes thoroughly with water, and consult a doctor in case of fuel contact with the eyes.
- Change your clothing in case of fuel spills on them.

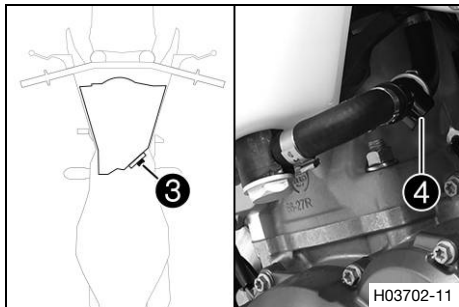
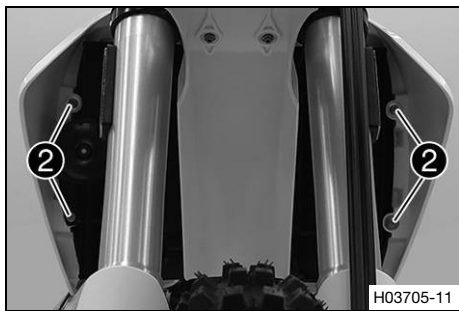
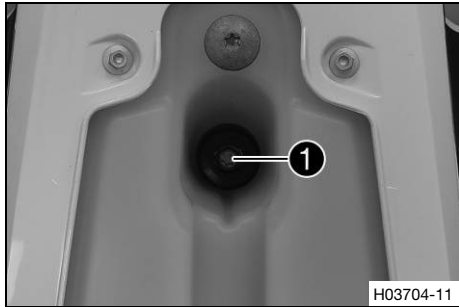
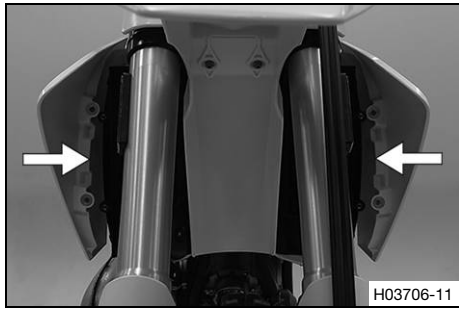

Main work

- Check the throttle cable routing. (📖 p. 82)
- Position the fuel tank and fit the two spoilers to the sides in front of the radiator bracket.
- Make sure that no cables or throttle cables are trapped or damaged.

- Attach the fuel tank breather hose.
- Mount and tighten screw **1** with the rubber bushing.

Guideline

Remaining screws, chassis	M6	10 Nm (7.4 lbf ft)
---------------------------	----	--------------------

(TE 150i EU)

- Position the horn with the horn bracket.

- Mount and tighten screws **2**.

Guideline

Remaining screws, chassis	M6	10 Nm (7.4 lbf ft)
---------------------------	----	--------------------

- Plug in connector **3** for the fuel pump.
- Remove the wash cap set.
- Clean the quick release coupling thoroughly with compressed air.

i Info

Under no circumstances should dirt enter into the fuel line. Dirt in the fuel line clogs the injection valve!

- Spray silicone spray onto a lint-free cleaning cloth and lightly lubricate the O-ring of the quick-release coupling.

Silicone spray (📖 p. 157)

- Join quick release coupling **4**.

i Info

Route the cable and fuel line at a safe distance from the exhaust system.

- Attach the fuel tank breather hose.

Finishing work

- Install the right side cover. (📖 p. 73)
- Mount the seat. (📖 p. 68)

- Install the air filter box cover. (📖 p. 69)



12.32 Checking the chain for dirt

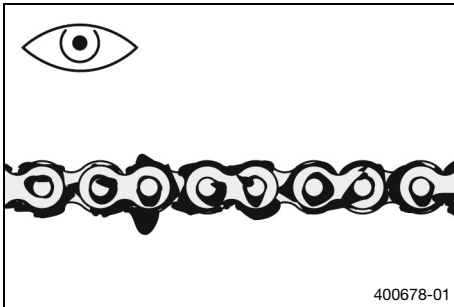

- Check the chain for heavy soiling.
 - » If the chain is very dirty:
 - Clean the chain. (📖 p. 77)



12.33 Cleaning the chain



Warning

Danger of accidents Lubricants on the tires reduces the road grip.

- Remove lubricants from the tires using a suitable cleaning agent.



Warning

Danger of accidents Oil or grease on the brake discs reduces the braking effect.

- Always keep the brake discs free of oil and grease.
- Clean the brake discs with brake cleaner when necessary.



Note

Environmental hazard Hazardous substances cause environmental damage.

- Dispose of oils, grease, filters, fuel, cleaning agents, brake fluid, etc., correctly and in compliance with the applicable regulations.



Info

The service life of the chain depends largely on its maintenance.

Preparatory work

- Raise the motorcycle with a lift stand. (📖 p. 56)

Main work

- Rinse off loose dirt with a soft jet of water.
- Remove old grease residue with chain cleaner.

Chain cleaner (📖 p. 157)

- After drying, apply chain spray.

Off-road chain spray (📖 p. 157)

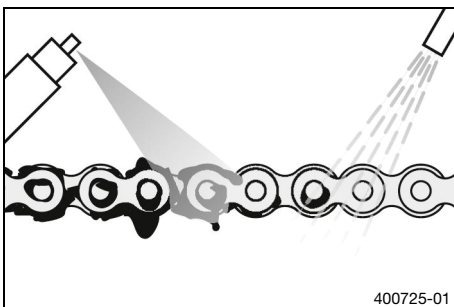

Finishing work

- Remove the motorcycle from the lift stand. (📖 p. 56)



12.34 Checking the chain tension



Warning

Danger of accidents Incorrect chain tension damages components and results in accidents.

If the chain is tensioned too much, the chain, engine sprocket, rear sprocket, transmission and rear wheel bearings wear more quickly. Some components may break if overloaded.

If the chain is too loose, the chain may fall off the engine sprocket or the rear sprocket. As a result, the rear wheel locks or the engine will be damaged.

- Check the chain tension regularly.
- Set the chain tension in accordance with the specification.

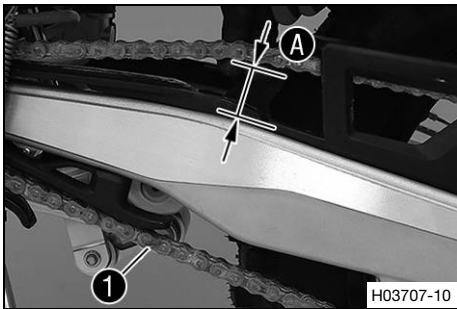

Preparatory work

- Raise the motorcycle with a lift stand. (📖 p. 56)

Main work

- Pull the chain at the end of the chain sliding piece upward to measure chain tension **A**.



Info

Lower chain section **1** must be taut.

Chain wear is not always even, so you should repeat this measurement at different chain positions.

Chain tension	55 ... 58 mm (2.17 ... 2.28 in)
---------------	---------------------------------

- » If the chain tension does not meet the specification:
 - Adjust the chain tension. (📖 p. 78)

Finishing work

- Remove the motorcycle from the lift stand. (📖 p. 56)

12.35 Adjusting the chain tension



Warning

Danger of accidents Incorrect chain tension damages components and results in accidents.

If the chain is tensioned too much, the chain, engine sprocket, rear sprocket, transmission and rear wheel bearings wear more quickly. Some components may break if overloaded.

If the chain is too loose, the chain may fall off the engine sprocket or the rear sprocket. As a result, the rear wheel locks or the engine will be damaged.

- Check the chain tension regularly.
- Set the chain tension in accordance with the specification.

Preparatory work

- Raise the motorcycle with a lift stand. (📖 p. 56)
- Check the chain tension. (📖 p. 78)

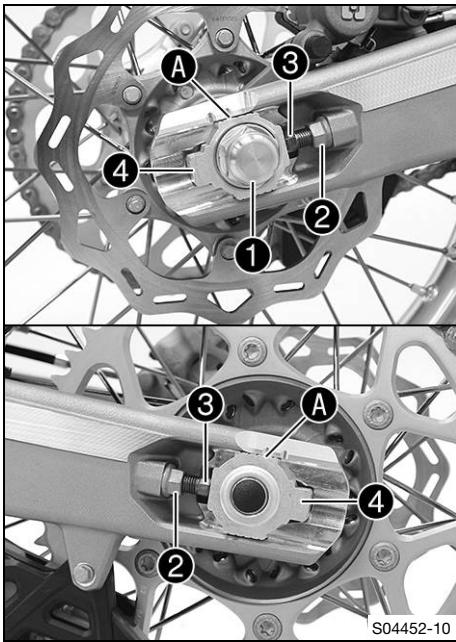

Main work

- Loosen nut ①.
- Loosen nuts ②.
- Adjust the chain tension by turning adjusting screws ③ left and right.

Guideline

Chain tension	55 ... 58 mm (2.17 ... 2.28 in)
---------------	---------------------------------

Turn adjusting screws ③ on the left and right so that the markings on the left and right chain adjusters are in the same position relative to reference marks A. The rear wheel is then correctly aligned.

- Tighten nuts ②.
- Make sure that chain adjusters ④ are fitted correctly on adjusting screws ③.
- Tighten nut ①.

Guideline

Nut, rear wheel spindle	M20x1.5	80 Nm (59 lbf ft)
-------------------------	---------	-------------------



Info

The wide adjustment range of the chain adjusters (32 mm (1.26 in)) enables different secondary ratios with the same chain length. Chain adjusters ④ can be turned by 180°.

Finishing work

- Remove the motorcycle from the lift stand. (📖 p. 56)



12.36 Checking the chain, rear sprocket, engine sprocket, and chain guide

Preparatory work

- Raise the motorcycle with a lift stand. (📖 p. 56)

Main work

- Shift the transmission into neutral.
- Check the chain, rear sprocket, and engine sprocket for wear.
 - » If the chain, rear sprocket or engine sprocket is worn:
 - Change the drivetrain kit. 🛠️



Info

The engine sprocket, rear sprocket, and chain should always be replaced together.

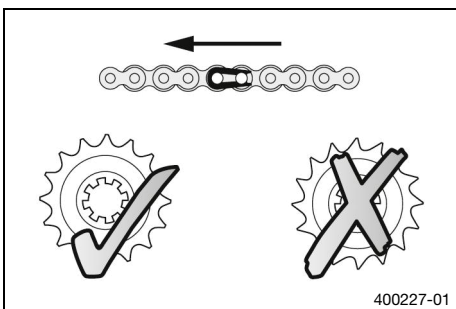

400227-01

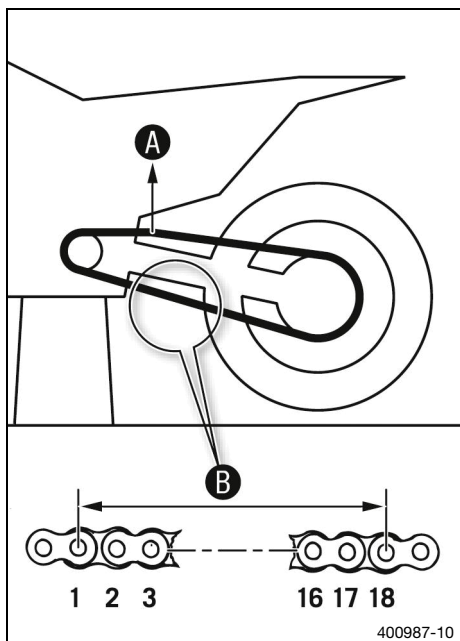

- Pull on the top section of the chain with the specified weight **A**.

Guideline

Weight, chain wear measurement	10 ... 15 kg (22 ... 33 lb.)
--------------------------------	------------------------------

- Measure distance **B** of 18 chain rollers in the lower chain section.

i Info
Chain wear is not always even, so you should repeat this measurement at different chain positions.

Maximum distance B from 18 chain rollers at the longest chain section	272 mm (10.71 in)
--	-------------------

- » If distance **B** is greater than the specified measurement:
 - Change the drivetrain kit. 🛠️

i Info
When a new chain is mounted, the rear sprocket and engine sprocket should also be changed.
New chains wear out faster on old, worn sprockets.

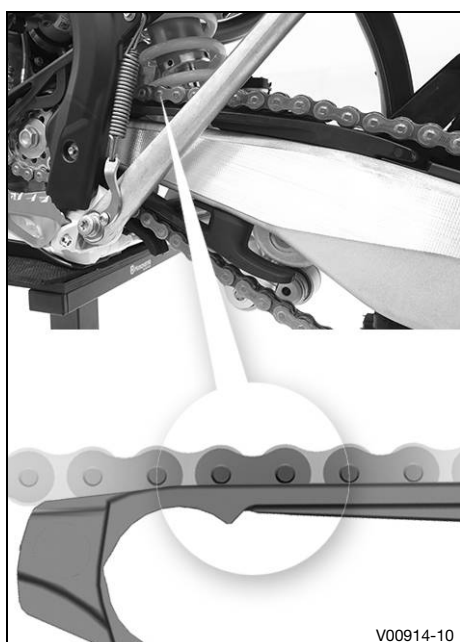

- Check the chain sliding guard for wear.
 - » If the lower edge of the chain pins is in line with, or below, the chain sliding guard:
 - Change the chain sliding guard. 🛠️
- Check that the chain sliding guard is firmly seated.
 - » If the chain sliding guard is loose:
 - Tighten screws on the chain sliding guard.

Guideline

Screw, chain sliding guard	M6	10 Nm (7.4 lbf ft) Loctite®243™
----------------------------	----	---

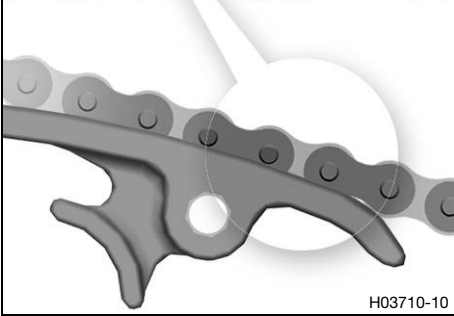

- Check the chain sliding piece for wear.
 - » If the lower edge of the chain pins is in line with or below the chain sliding piece:
 - Change the chain sliding piece. 🛠️
- Check that the chain sliding piece is firmly seated.
 - » If the chain sliding piece is loose:
 - Tighten screw on the chain sliding piece.

Guideline

Screw, chain sliding piece	M8	15 Nm (11.1 lbf ft)
----------------------------	----	------------------------

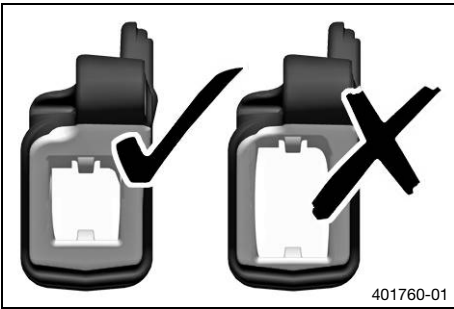

- Check the chain guide for wear.



Info

Wear can be seen on the front of the chain guide.

- » If the light part of the chain guide is worn:
 - Change the chain guide. 🛠️



- Check that the chain guide is firmly seated.
 - » If the chain guide is loose:
 - Tighten the screws on the chain guide.

Guideline

Remaining screws, chassis	M6	10 Nm (7.4 lbf ft)
Remaining nuts, chassis	M6	10 Nm (7.4 lbf ft)

Finishing work

- Remove the motorcycle from the lift stand. (📖 p. 56)

12.37 Checking the frame

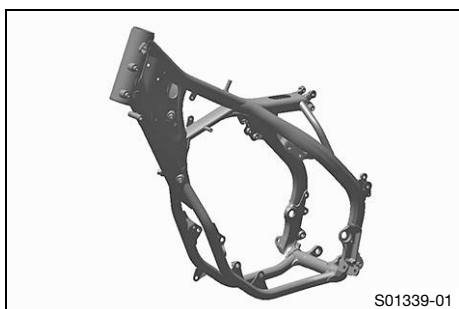

- Check the frame for damage, cracks, and deformation.
 - » If the frame shows signs of damage, cracks, or deformation:

- Change the frame.

Guideline

Repairs on the frame are not permitted.

12.38 Checking the link fork

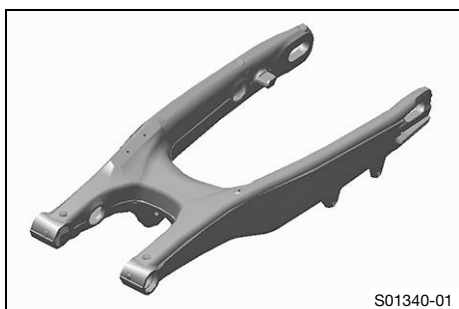

- Check the link fork for damage, cracking, and deformation.
 - » If the link fork exhibits damage, cracking, or deformation:
- Change the link fork.



Info

Always replace a damaged link fork. Repair of the link fork is not authorized by Husqvarna Motorcycles.

12.39 Checking the throttle cable routing

Preparatory work

- Remove the air filter box cover. (p. 69)
- Remove the seat. (p. 68)
- Remove the right side cover. (p. 73)
- Remove the fuel tank. (p. 74)

Main work

- Check the throttle cable routing.

Both throttle cables must be routed, side by side, on the back of the handlebars, above the fuel tank bracket on the right of the frame to the throttle valve body. Both throttle cables must be secured behind the rubber strap of the fuel tank support.

- » If the throttle cable is not routed as specified:
 - Correct the throttle cable routing.



Finishing work

- Install the fuel tank. (🔧 p. 75)
- Install the right side cover. (🔧 p. 73)
- Mount the seat. (🔧 p. 68)
- Install the air filter box cover. (🔧 p. 69)



12.40 Checking the rubber grip

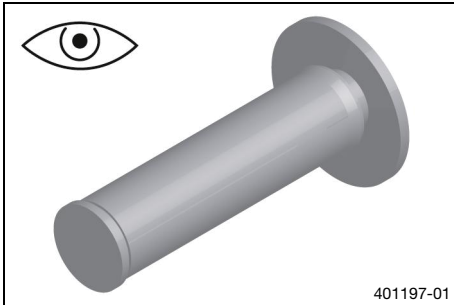

- Check the rubber grips on the handlebar for damage, wear, and looseness.



Info

The rubber grips are vulcanized onto a sleeve on the left and onto the handle tube of the throttle grip on the right. The left sleeve is clamped onto the handlebar. The rubber grip can only be replaced with the sleeve or the throttle tube.

- » If a rubber grip is damaged or worn:
 - Change the rubber grip.

- Check that screw ❶ is firmly seated.

Guideline

Screw, fixed grip	M4	5 Nm (3.7 lbf ft) Loctite®243™
-------------------	----	--

Diamond ❶ must be positioned visibly as shown in the figure.

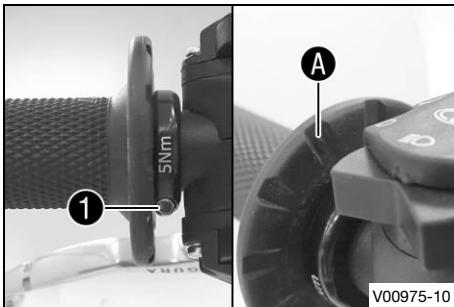

12.41 Adjusting the basic position of the clutch lever

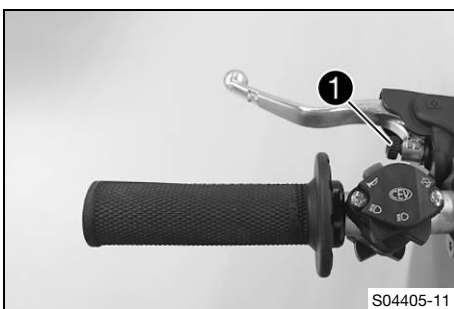

- Adjust the basic position of the clutch lever to your hand size by turning adjusting screw ❶.



Info

When the adjusting screw is turned counterclockwise, the clutch lever moves away from the handlebar. When the adjusting screw is turned clockwise, the clutch lever moves closer to the handlebar. The range of adjustment is limited. Turn the adjusting screw by hand only, and do not apply any force. Do not make any adjustments while riding.



12.42 Checking/correcting the fluid level of the hydraulic clutch



Warning

Skin irritation Brake fluid causes skin irritation.

- Keep brake fluid out of the reach of children.
- Wear suitable protective clothing and safety glasses.
- Do not allow brake fluid to come into contact with the skin, the eyes or clothing.
- Consult a doctor immediately if brake fluid has been swallowed.
- Rinse the affected area with plenty of water in the event of contact with the skin.
- Rinse eyes thoroughly with water immediately and consult a doctor if brake fluid comes into contact with the eyes.
- If brake fluid spills on to your clothing, change the clothing.



Note

Environmental hazard Hazardous substances cause environmental damage.

- Dispose of oils, grease, filters, fuel, cleaning agents, brake fluid, etc., correctly and in compliance with the applicable regulations.



Info

The fluid level rises with increasing wear of the clutch facing discs.

Never use DOT 5 brake fluid. It is silicone-based and purple in color. Oil seals and clutch lines are not designed for DOT 5 brake fluid.

Avoid contact between brake fluid and painted parts. Brake fluid attacks paint.

Only use clean brake fluid from a sealed container.

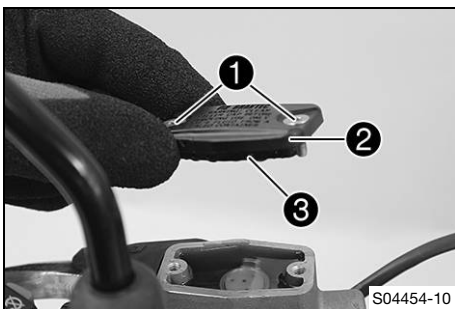

- Move the clutch fluid reservoir mounted on the handlebar to a horizontal position.
- Remove screws ①.
- Take off cover ② with membrane ③.
- Check the fluid level.

Fluid level below container rim	4 mm (0.16 in)
---------------------------------	----------------

» If the level of the fluid does not meet specifications:

- Correct the fluid level of the hydraulic clutch.

Brake fluid DOT 4 / DOT 5.1 (📖 p. 155)
--

- Position cover with membrane. Mount and tighten screws.



Info

Clean up overflowed or spilled brake fluid immediately with water.

12.43 Changing the hydraulic clutch fluid



Warning

Skin irritation Brake fluid causes skin irritation.

- Keep brake fluid out of the reach of children.
- Wear suitable protective clothing and safety glasses.
- Do not allow brake fluid to come into contact with the skin, the eyes or clothing.
- Consult a doctor immediately if brake fluid has been swallowed.
- Rinse the affected area with plenty of water in the event of contact with the skin.
- Rinse eyes thoroughly with water immediately and consult a doctor if brake fluid comes into contact with the eyes.
- If brake fluid spills on to your clothing, change the clothing.



Note

Environmental hazard Hazardous substances cause environmental damage.

- Dispose of oils, grease, filters, fuel, cleaning agents, brake fluid, etc., correctly and in compliance with the applicable regulations.



Info

Never use DOT 5 brake fluid. It is silicone-based and purple in color. Oil seals and clutch lines are not designed for DOT 5 brake fluid.

Avoid contact between brake fluid and painted parts. Brake fluid attacks paint.

Only use clean brake fluid from a sealed container.

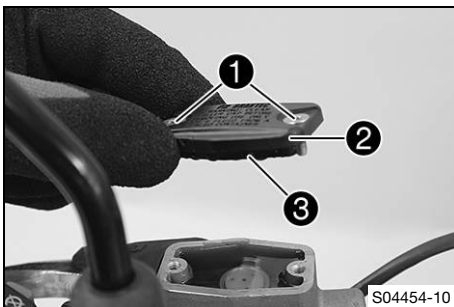

- Move the hydraulic clutch fluid reservoir mounted on the handlebar into a horizontal position.
- Remove screws ①.
- Take off cover ② with membrane ③.

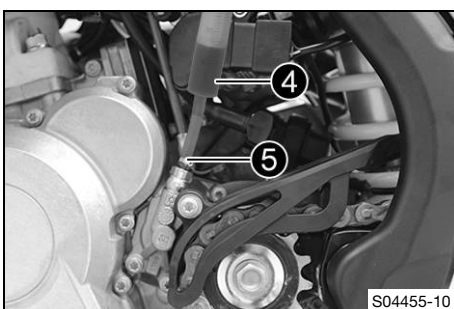

- Fill bleeding syringe ④ with the appropriate hydraulic fluid.

Syringe (50329050000)
Brake fluid DOT 4 / DOT 5.1 (📖 p. 155)

- On the slave cylinder, remove bleeder screw ⑤ and mount bleeding syringe ④.

12 SERVICE WORK ON THE CHASSIS

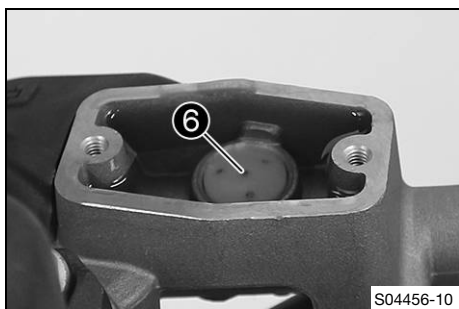

- Now press the fluid into the system until it emerges from hole 6 of the master cylinder without bubbles.
- Occasionally extract the fluid from the master cylinder reservoir to prevent overflowing.
- Remove the bleeding syringe. Mount and tighten the bleeder screw. Mount the protection cap.
- Correct the fluid level of the hydraulic clutch.

Guideline

Fluid level below container rim	4 mm (0.16 in)
---------------------------------	----------------

- Position the cover with the membrane. Mount and tighten the screws.

i Info
Immediately clean up any brake fluid that has overflowed or spilled with water.

12.44 Removing the engine guard

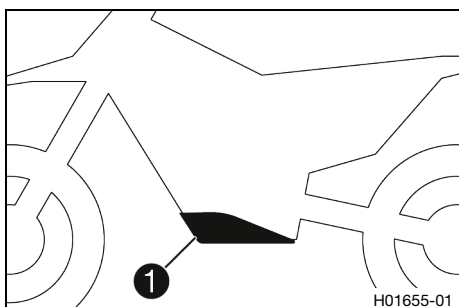

- Remove screws 1 and engine guard.

12.45 Installing the engine guard

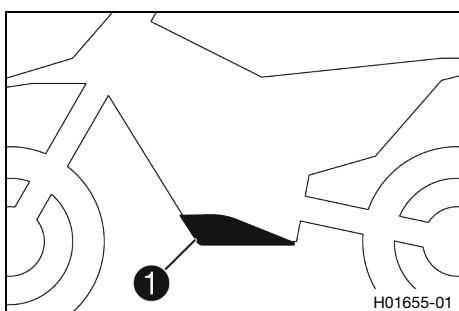

- Attach the engine guard on the frame at the rear and swing up at the front.
- Mount and tighten screws 1.

Guideline

Remaining screws, chassis	M6	10 Nm (7.4 lbf ft)
---------------------------	----	--------------------

13.1 Adjusting the basic position of the hand brake lever

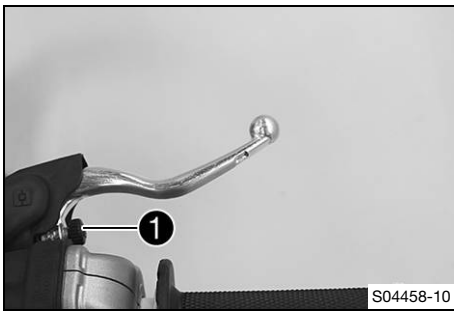

- Adjust the basic position of the hand brake lever to your hand size by turning adjusting screw ❶.



Info

Turn the adjusting screw clockwise to decrease the distance between the hand brake lever and the handlebar.
Turn the adjusting screw counterclockwise to increase the distance between the hand brake lever and the handlebar.
The range of adjustment is limited.
Turn the adjusting screw by hand only, and do not apply any force.
Do not make any adjustments while riding.



13.2 Checking the brake discs



Warning

Danger of accidents Worn-out brake discs reduce the braking effect.

- Make sure that worn-out brake discs are replaced immediately. (Your authorized Husqvarna Motorcycles workshop will be glad to help.)

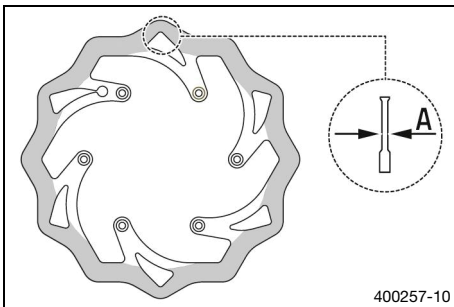

- Check the front and rear brake disc thickness at multiple points for the dimension A.



Info

Wear reduces the thickness of the brake disc around the contact surface of the brake linings.

Brake discs - wear limit	
front	2.5 mm (0.098 in)
rear	3.5 mm (0.138 in)

- » If the brake disc thickness is less than the specified value:
 - Change the front brake disc. 🛠️
 - Change the rear brake disc. 🛠️
- Check the front and rear brake discs for damage, cracking, and deformation.
 - » If the brake disc exhibits damage, cracking, or deformation:
 - Change the front brake disc. 🛠️
 - Change the rear brake disc. 🛠️



13.3 Checking the front brake fluid level



Warning

Danger of accidents An insufficient brake fluid level will cause the brake system to fail.

If the brake fluid level drops below the specified marking or the specified value, the brake system is leaking or the brake linings are worn down.

- Check the brake system and do not continue riding until the problem is eliminated. (Your authorized Husqvarna Motorcycles workshop will be glad to help.)



Warning

Danger of accidents Old brake fluid reduces the braking effect.

- Make sure that brake fluid for the front and rear brake is changed in accordance with the service schedule. (Your authorized Husqvarna Motorcycles workshop will be glad to help.)

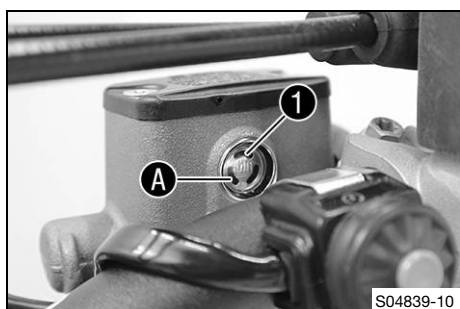

- Move the brake reservoir mounted on the handlebar to a horizontal position.
- Check the brake fluid level in level viewer ①.
 - » If the brake fluid level has dropped below the marking A:
- Add front brake fluid. 📖 (p. 88)

13.4 Adding front brake fluid 📖



Warning

Danger of accidents An insufficient brake fluid level will cause the brake system to fail.

If the brake fluid level drops below the specified marking or the specified value, the brake system is leaking or the brake linings are worn down.

- Check the brake system and do not continue riding until the problem is eliminated. (Your authorized Husqvarna Motorcycles workshop will be glad to help.)



Warning

Skin irritation Brake fluid causes skin irritation.

- Keep brake fluid out of the reach of children.
- Wear suitable protective clothing and safety glasses.
- Do not allow brake fluid to come into contact with the skin, the eyes or clothing.
- Consult a doctor immediately if brake fluid has been swallowed.
- Rinse the affected area with plenty of water in the event of contact with the skin.
- Rinse eyes thoroughly with water immediately and consult a doctor if brake fluid comes into contact with the eyes.
- If brake fluid spills on to your clothing, change the clothing.



Warning

Danger of accidents Old brake fluid reduces the braking effect.

- Make sure that brake fluid for the front and rear brake is changed in accordance with the service schedule. (Your authorized Husqvarna Motorcycles workshop will be glad to help.)



Note

Environmental hazard Hazardous substances cause environmental damage.

- Dispose of oils, grease, filters, fuel, cleaning agents, brake fluid, etc., correctly and in compliance with the applicable regulations.



Info

Never use DOT 5 brake fluid. It is silicone-based and purple in color. Oil seals and brake lines are not designed for DOT 5 brake fluid.

Avoid contact between brake fluid and painted parts. Brake fluid attacks paint.

Only use clean brake fluid from a sealed container.

Preparatory work

- Check the front brake linings. (📖 p. 89)

Main work

- Move the brake reservoir mounted on the handlebar to a horizontal position.
- Remove screws ①.
- Take off cover ② with membrane ③.
- Add brake fluid to level A.

Guideline

Level A (brake fluid level below reservoir rim)	5 mm (0.2 in)
---	---------------

Brake fluid DOT 4 / DOT 5.1 (📖 p. 155)
--

- Position the cover with the membrane. Mount and tighten the screws.

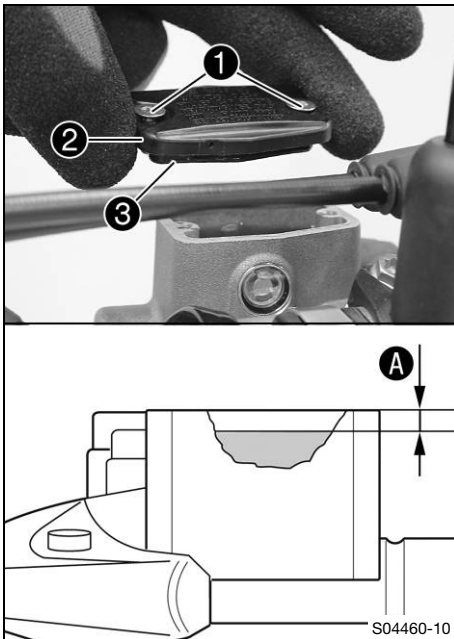

Info

Clean up overflowed or spilled brake fluid immediately with water.

13.5 Checking the front brake linings



Warning

Danger of accidents Worn-out brake linings reduce the braking effect.

- Ensure that worn-out brake linings are replaced immediately. (Your authorized Husqvarna Motorcycles workshop will be glad to help.)

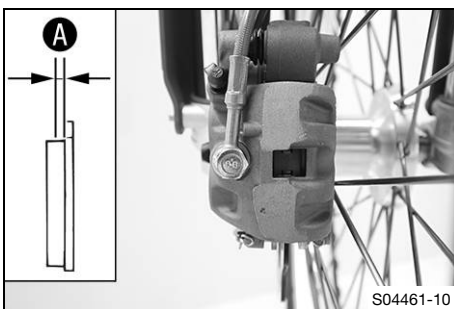

- Check the brake linings for minimum thickness A.

Minimum thickness A	≥ 1 mm (≥ 0.04 in)
---------------------	--------------------

- » If the minimum thickness is less than specified:
 - Change the brake linings of the front brake. 🛠️ (📖 p. 90)
- Check the brake linings for damage and cracking.
 - » If damage or wear is encountered:
 - Change the brake linings of the front brake. 🛠️ (📖 p. 90)

13.6 Changing the brake linings of the front brake ↻



Warning

Danger of accidents Incorrect servicing will cause the brake system to fail.

- Ensure that service work and repairs are performed professionally. (Your authorized Husqvarna Motorcycles workshop will be glad to help.)



Warning

Skin irritation Brake fluid causes skin irritation.

- Keep brake fluid out of the reach of children.
- Wear suitable protective clothing and safety glasses.
- Do not allow brake fluid to come into contact with the skin, the eyes or clothing.
- Consult a doctor immediately if brake fluid has been swallowed.
- Rinse the affected area with plenty of water in the event of contact with the skin.
- Rinse eyes thoroughly with water immediately and consult a doctor if brake fluid comes into contact with the eyes.
- If brake fluid spills on to your clothing, change the clothing.



Warning

Danger of accidents Old brake fluid reduces the braking effect.

- Make sure that brake fluid for the front and rear brake is changed in accordance with the service schedule. (Your authorized Husqvarna Motorcycles workshop will be glad to help.)



Warning

Danger of accidents Oil or grease on the brake discs reduces the braking effect.

- Always keep the brake discs free of oil and grease.
- Clean the brake discs with brake cleaner when necessary.



Warning

Danger of accidents Brake linings which have not been approved alter the braking efficiency.

Not all brake linings are tested and approved for Husqvarna motorcycles. The structure and friction coefficient of the brake linings, and thus their brake power, may vary greatly from that of original brake linings.

If brake linings are used that differ from the original equipment, compliance with the original homologation is not guaranteed. In this case, the vehicle no longer corresponds to its condition at delivery and the manufacturer warranty shall be void.

- Only use brake linings approved and recommended by Husqvarna motorcycles.



Note

Environmental hazard Hazardous substances cause environmental damage.

- Dispose of oils, grease, filters, fuel, cleaning agents, brake fluid, etc., correctly and in compliance with the applicable regulations.



Info

Never use DOT 5 brake fluid. It is silicone-based and purple in color. Oil seals and brake lines are not designed for DOT 5 brake fluid.

Avoid contact between the brake fluid and painted parts. Brake fluid corrodes paint.

Only use clean brake fluid from a sealed container.

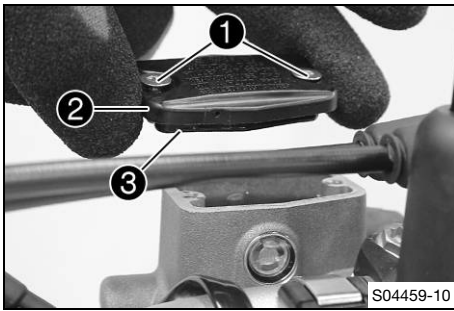

- Move the brake fluid reservoir mounted on the handlebar to a horizontal position.
- Remove screws ①.
- Take off cover ② with membrane ③.

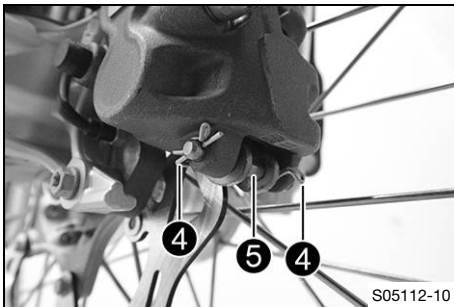

- Manually press the brake caliper toward the brake disc to push back the brake pistons. Ensure that brake fluid does not flow out of the brake fluid reservoir, extract some if necessary.



Info

Make sure that you do not press the brake caliper against the spokes when pushing back the brake pistons.

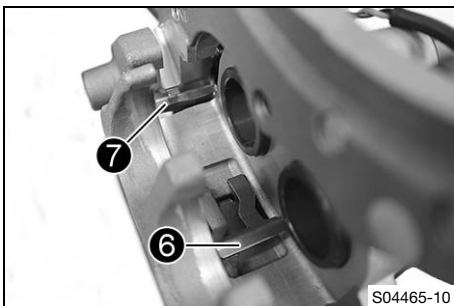

- Remove cotter pin ④.
- Pull out pin ⑤.
- Remove the brake linings.
- Clean the brake caliper and the brake caliper bracket.
- Check that spring plate ⑥ in the brake caliper and brake pad sliding plate ⑦ in the brake caliper bracket are seated correctly.



- Insert the new brake linings.
- Mount pin ⑤.
- ✓ Spring plate ⑥ engages in the groove on the pin.



Info

Always change the brake linings in pairs.

- Mount cotter pins ④.

Guideline

Mount the outer cotter pins from the front to the rear.
Mount the inner cotter pins from the rear to the front.

- Operate the hand brake lever repeatedly until the brake linings are in contact with the brake disc and there is a pressure point.

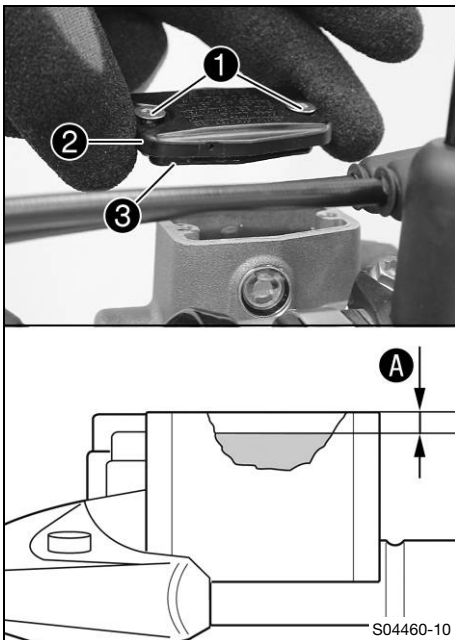

- Add brake fluid up to level A.

Guideline

Level A (brake fluid level below reservoir rim)	5 mm (0.2 in)
---	---------------

Brake fluid DOT 4 / DOT 5.1 (📖 p. 155)

- Position cover ② with membrane ③.
- Mount and tighten screws ①.



Info

Use water to immediately clean up any brake fluid that has overflowed or spilled.

13.7 Checking the free travel of the foot brake lever



Warning

Danger of accidents The brake system fails in the event of overheating.

If there is no free travel on the foot brake lever, pressure builds up in the brake system on the rear brake.

- Set the free travel on the foot brake lever in accordance with the specification.

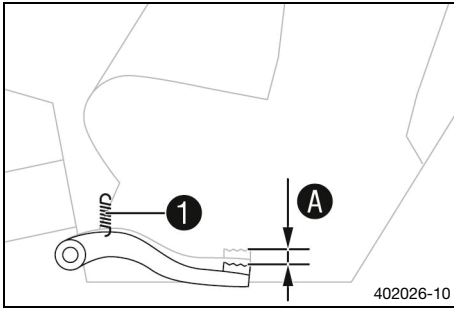

- Disconnect spring **1**.
- Move the foot brake lever backwards and forwards between the end stop and the foot brake cylinder piston bracket and check free travel **A**.

Guideline

Free travel of foot brake lever	3 ... 5 mm (0.12 ... 0.2 in)
---------------------------------	------------------------------

» If the free travel does not meet specifications:

- Adjust the basic position of the foot brake lever. (p. 93)
- Reconnect spring **1**.



13.8 Adjusting the basic position of the foot brake lever



Warning

Danger of accidents The brake system fails in the event of overheating.

If there is no free travel on the foot brake lever, pressure builds up in the brake system on the rear brake.

- Set the free travel on the foot brake lever in accordance with the specification.

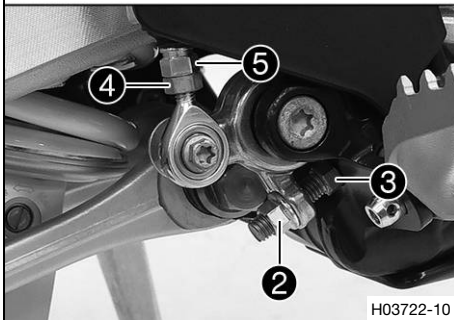
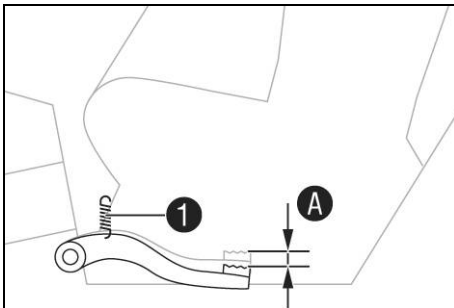

- Detach spring **1**.
- Loosen nut **4** and, with push rod **5**, turn it back until you have maximum free travel.
- To adjust the basic position of the foot brake lever to individual requirements, loosen nut **2** and turn screw **3** accordingly.

Info

The range of adjustment is limited.

- Turn push rod **5** accordingly until you have free travel **A**. If necessary, adjust the basic position of the foot brake lever.

Guideline

Free travel of foot brake lever	3 ... 5 mm (0.12 ... 0.2 in)
---------------------------------	------------------------------

- Hold screw **3** and tighten nut **2**.

Guideline

Nut, foot brake lever stop	M8	20 Nm (14.8 lbf ft)
----------------------------	----	---------------------

- Hold push rod **5** and tighten nut **4**.

Guideline

Remaining nuts, chassis	M6	10 Nm (7.4 lbf ft)
-------------------------	----	--------------------

- Attach spring **1**.



13.9 Checking the rear brake fluid level



Warning

Danger of accidents An insufficient brake fluid level will cause the brake system to fail.

If the brake fluid level drops below the specified marking or the specified value, the brake system is leaking or the brake linings are worn down.

- Check the brake system and do not continue riding until the problem is eliminated. (Your authorized Husqvarna Motorcycles workshop will be glad to help.)



Warning

Danger of accidents Old brake fluid reduces the braking effect.

- Make sure that brake fluid for the front and rear brake is changed in accordance with the service schedule. (Your authorized Husqvarna Motorcycles workshop will be glad to help.)

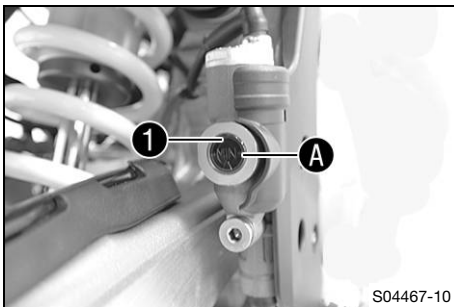

- Stand the vehicle upright.
- Check the brake fluid level in viewer ①.
 - » If the brake fluid level has dropped below marking A:
 - Add rear brake fluid. 🛠️ (p. 94)

13.10 Adding rear brake fluid 🛠️



Warning

Danger of accidents An insufficient brake fluid level will cause the brake system to fail.

If the brake fluid level drops below the specified marking or the specified value, the brake system is leaking or the brake linings are worn down.

- Check the brake system and do not continue riding until the problem is eliminated. (Your authorized Husqvarna Motorcycles workshop will be glad to help.)



Warning

Skin irritation Brake fluid causes skin irritation.

- Keep brake fluid out of the reach of children.
- Wear suitable protective clothing and safety glasses.
- Do not allow brake fluid to come into contact with the skin, the eyes or clothing.
- Consult a doctor immediately if brake fluid has been swallowed.
- Rinse the affected area with plenty of water in the event of contact with the skin.
- Rinse eyes thoroughly with water immediately and consult a doctor if brake fluid comes into contact with the eyes.
- If brake fluid spills on to your clothing, change the clothing.



Warning

Danger of accidents Old brake fluid reduces the braking effect.

- Make sure that brake fluid for the front and rear brake is changed in accordance with the service schedule. (Your authorized Husqvarna Motorcycles workshop will be glad to help.)

**Note****Environmental hazard** Hazardous substances cause environmental damage.

- Dispose of oils, grease, filters, fuel, cleaning agents, brake fluid, etc., correctly and in compliance with the applicable regulations.

**Info**

Never use DOT 5 brake fluid. It is silicone-based and purple in color. Oil seals and brake lines are not designed for DOT 5 brake fluid.

Avoid contact between brake fluid and painted parts. Brake fluid attacks paint.

Only use clean brake fluid from a sealed container.

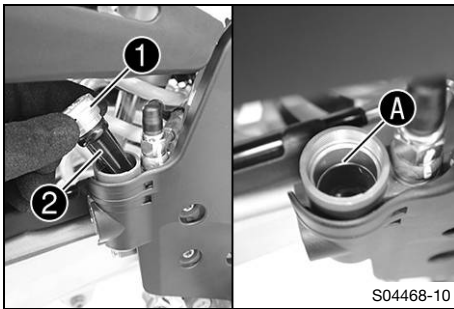
**Preparatory work**

- Check the brake linings of the rear brake. (📖 p. 95)

Main work

- Stand the vehicle upright.
- Remove the cable ties on the frame protector.
- Remove screw cap ① with membrane ② and the shim.
- Add brake fluid up to the marking A.

Brake fluid DOT 4 / DOT 5.1 (📖 p. 155)
--

- Mount and tighten screw cap with the membrane and the shim.

**Info**

Clean up overflowed or spilled brake fluid immediately with water.

- Mount new cable ties on the frame protector.

13.11 Checking the brake linings of the rear brake**Warning****Danger of accidents** Worn-out brake linings reduce the braking effect.

- Ensure that worn-out brake linings are replaced immediately. (Your authorized Husqvarna Motorcycles workshop will be glad to help.)

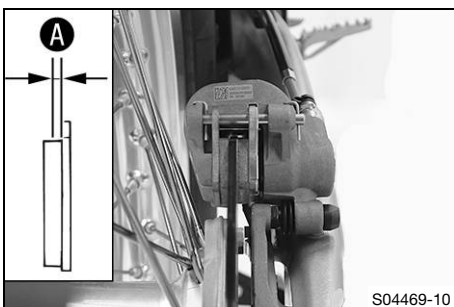

- Check the brake linings for minimum thickness A.

Minimum thickness A	≥ 1 mm (≥ 0.04 in)
---------------------	--------------------

- » If the minimum thickness is less than specified:
 - Change the rear brake linings. (📖 p. 96)
- Check the brake linings for damage and cracking.
 - » If damage or wear is encountered:
 - Change the rear brake linings. (📖 p. 96)

13.12 Changing the rear brake linings ↴



Warning

Danger of accidents Incorrect servicing will cause the brake system to fail.

- Ensure that service work and repairs are performed professionally. (Your authorized Husqvarna Motorcycles workshop will be glad to help.)



Warning

Skin irritation Brake fluid causes skin irritation.

- Keep brake fluid out of the reach of children.
- Wear suitable protective clothing and safety glasses.
- Do not allow brake fluid to come into contact with the skin, the eyes or clothing.
- Consult a doctor immediately if brake fluid has been swallowed.
- Rinse the affected area with plenty of water in the event of contact with the skin.
- Rinse eyes thoroughly with water immediately and consult a doctor if brake fluid comes into contact with the eyes.
- If brake fluid spills on to your clothing, change the clothing.



Warning

Danger of accidents Old brake fluid reduces the braking effect.

- Make sure that brake fluid for the front and rear brake is changed in accordance with the service schedule. (Your authorized Husqvarna Motorcycles workshop will be glad to help.)



Warning

Danger of accidents Oil or grease on the brake discs reduces the braking effect.

- Always keep the brake discs free of oil and grease.
- Clean the brake discs with brake cleaner when necessary.



Warning

Danger of accidents Brake linings which have not been approved alter the braking efficiency.

Not all brake linings are tested and approved for Husqvarna motorcycles. The structure and friction coefficient of the brake linings, and thus their brake power, may vary greatly from that of original brake linings.

If brake linings are used that differ from the original equipment, compliance with the original homologation is not guaranteed. In this case, the vehicle no longer corresponds to its condition at delivery and the manufacturer warranty shall be void.

- Only use brake linings approved and recommended by Husqvarna motorcycles.



Note

Environmental hazard Hazardous substances cause environmental damage.

- Dispose of oils, grease, filters, fuel, cleaning agents, brake fluid, etc., correctly and in compliance with the applicable regulations.



Info

Never use DOT 5 brake fluid. It is silicone-based and purple in color. Oil seals and brake lines are not designed for DOT 5 brake fluid.

Avoid contact between brake fluid and painted parts. Brake fluid corrodes paint.

Only use clean brake fluid from a sealed container.

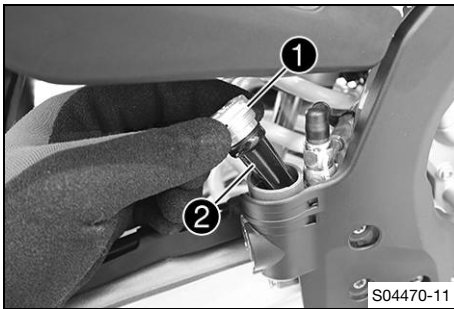

- Position the vehicle vertically.
- Remove the cable tie on the frame protector.
- Remove screw cap ① with membrane ② and the shim.

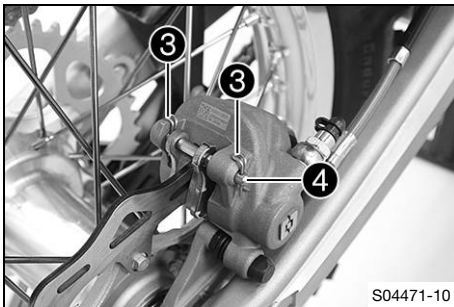

- Manually press the brake caliper toward the brake disc to push back the brake piston. Ensure that brake fluid does not flow out of the brake fluid reservoir; extract some if necessary.

i Info
Make sure that you do not press the brake caliper against the spokes when pushing back the brake piston.

- Remove cotter pin ③.
- Pull out pin ④.
- Remove the brake linings.
- Clean the brake caliper and the brake caliper bracket.
- Check that spring plate in the brake caliper and brake pad sliding plate in the brake caliper bracket are fitted correctly.

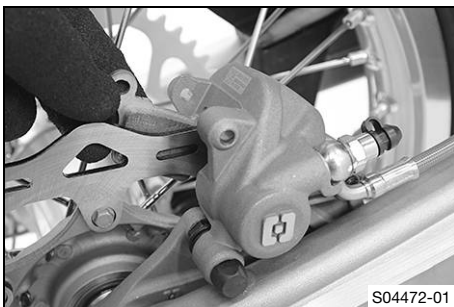

- Insert the new brake linings.
- Mount pin ④.
- ✓ The spring plate engages in the groove on the pin.

i Info
Always change the brake linings in pairs.

- Mount cotter pins ③.
- Operate the foot brake lever repeatedly until the brake linings are in contact with the brake disc and there is a pressure point.

- Correct brake fluid level to marking A.

Brake fluid DOT 4 / DOT 5.1 (📖 p. 155)

- Mount and tighten screw cap ① with membrane ② and the shim.

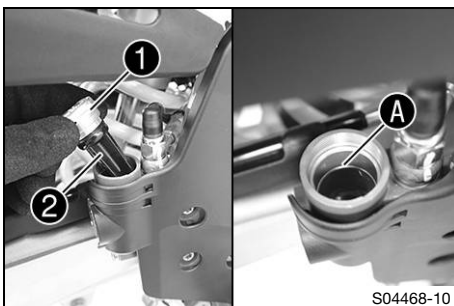

i Info
Use water to immediately clean up any brake fluid that has overflowed or spilled.

- Mount new cable ties on the frame protector.

14.1 Removing the front wheel

Preparatory work

- Raise the motorcycle with a lift stand. (📖 p. 56)

Main work

- Manually press the brake caliper toward the brake disc to push back the brake pistons.



Info

Make sure that you do not press the brake caliper against the spokes when pushing back the brake pistons.



- Loosen screw ① by several rotations.
- Loosen screws ②.
- Press on screw ① to push the wheel spindle out of the axle clamp.
- Remove screw ①.

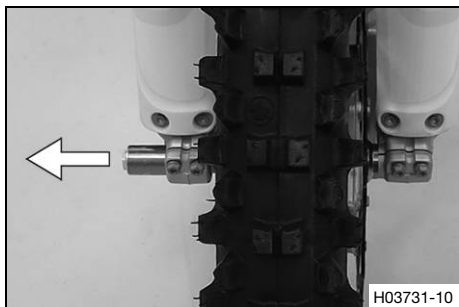

Warning

Danger of accidents Damaged brake discs reduce the braking effect.

- Always lay the wheel down in such a way that the brake disc is not damaged.

- Hold front wheel and remove wheel spindle. Take front wheel out of the fork.

Info

Do not actuate the hand brake lever when the front wheel is removed.

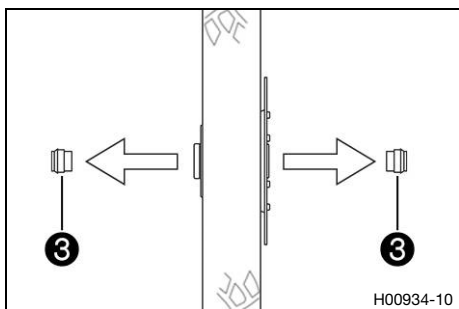

- Remove spacers ③.

14.2 Installing the front wheel ↴

Warning

Danger of accidents Oil or grease on the brake discs reduces the braking effect.

- Always keep the brake discs free of oil and grease.
- Clean the brake discs with brake cleaner when necessary.

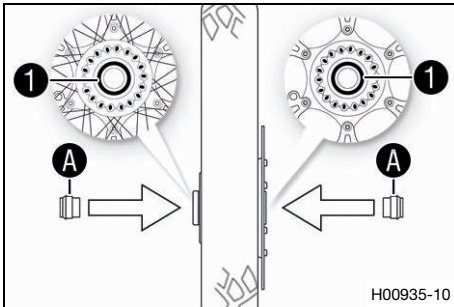

- Check the wheel bearing for damage and wear.
 - » If the wheel bearing is damaged or worn:
 - Change front wheel bearing. ↴
- Clean and grease shaft seal rings **1** and contact surfaces **A** of the spacers.

Long-life grease (📖 p. 157)

- Insert the spacers.
- Clean and grease the wheel spindle.

Long-life grease (📖 p. 157)

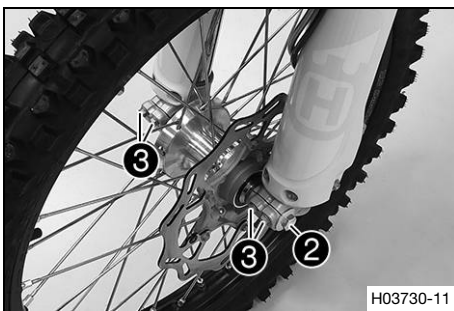

- Jack up the front wheel into the fork, position it, and insert the wheel spindle.
 - ✓ The brake linings are correctly positioned.
- Mount and tighten screw **2**.

Guideline

Screw, front wheel spindle	M20x1.5	35 Nm (25.8 lbf ft)
----------------------------	---------	---------------------

- Operate the hand brake lever several times until the brake linings are seated correctly against the brake disc.
- Remove the motorcycle from the lift stand. (📖 p. 56)
- Operate the front brake and compress the fork a few times firmly.
 - ✓ The fork legs straighten.
- Tighten screws **3**.

Guideline

Screw, fork stub	M8	15 Nm (11.1 lbf ft)
------------------	----	---------------------

14.3 Removing the rear wheel ↴

Preparatory work

- Raise the motorcycle with a lift stand. (📖 p. 56)

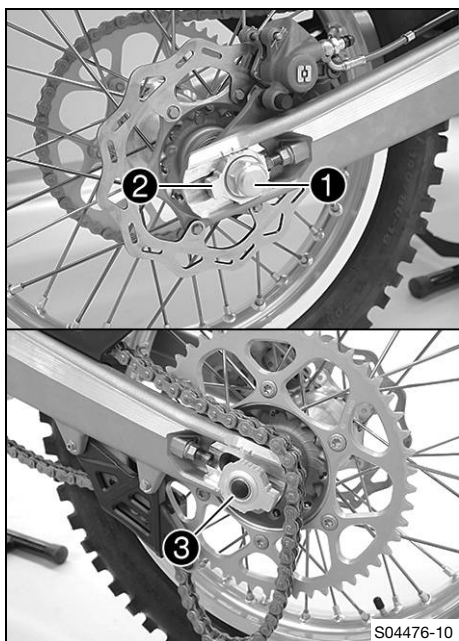

Main work

- Manually press the brake caliper toward the brake disc to push back the brake piston.

i Info

Make sure that you do not press the brake caliper against the spokes when pushing back the brake piston.

- Remove nut ①.
- Take off chain adjuster ②. Pull out wheel spindle ③ far enough to allow the rear wheel to be pushed forward.
- Push the rear wheel forward as far as possible. Remove the chain from the rear sprocket.

i Info

Cover the components to protect them against damage.



Warning

Danger of accidents Damaged brake discs reduce the braking effect.

- Always lay the wheel down in such a way that the brake disc is not damaged.

- Hold the rear wheel and remove the wheel spindle. Take the rear wheel out of the link fork.

i Info

Do not operate the foot brake lever when the rear wheel is removed.

- Remove spacers ④.

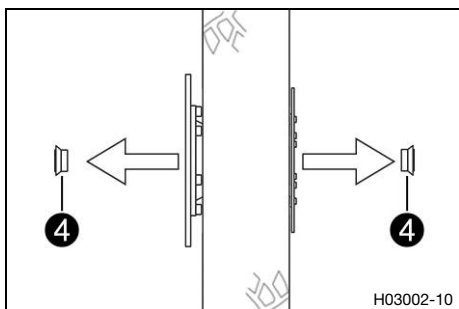

14.4 Installing the rear wheel ↩



Warning

Danger of accidents Oil or grease on the brake discs reduces the braking effect.

- Always keep the brake discs free of oil and grease.
- Clean the brake discs with brake cleaner when necessary.

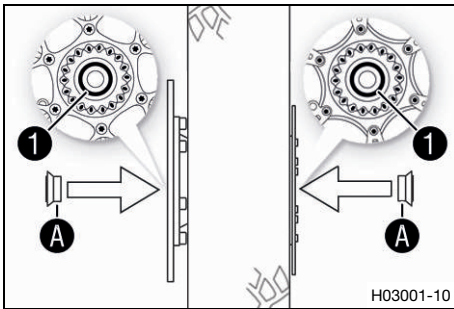

Main work

- Check the wheel bearing for damage and wear.
 - » If the wheel bearing is damaged or worn:
 - Change the rear wheel bearing. ↗
- Clean and grease shaft seal rings **1** and contact surfaces **A** of the spacers.

Long-life grease (📖 p. 157)

- Insert the spacers.
- Clean and grease the wheel spindle.

Long-life grease (📖 p. 157)



- Position rear wheel and insert wheel spindle **2**.
 - ✓ The brake linings are correctly positioned.
- Mount the chain.

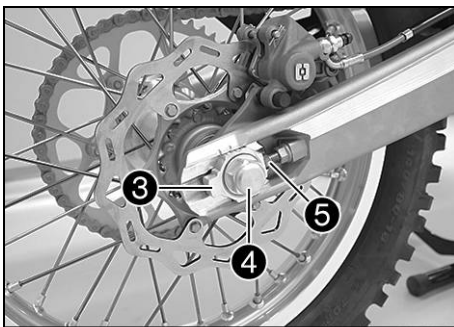

- Position chain adjuster **3**. Mount nut **4**, but do not tighten it yet.
- Make sure that chain adjusters **3** are fitted correctly on adjusting screws **5**.
- Check the chain tension. (📖 p. 78)
- Tighten nut **4**.

Guideline

Nut, rear wheel spindle	M20x1.5	80 Nm (59 lbf ft)
-------------------------	---------	-------------------



Info

The wide adjustment range of the chain adjusters (32 mm (1.26 in)) enables different secondary ratios with the same chain length.

Chain adjusters **3** can be turned by 180°.

- Operate the foot brake lever repeatedly until the brake linings are in contact with the brake disc and there is a pressure point.

Finishing work

- Remove the motorcycle from the lift stand. (📖 p. 56)



14.5 Checking the tire condition

i Info

Only mount tires approved and/or recommended by Husqvarna Motorcycles.

Other tires could have a negative effect on handling characteristics.

The type, condition, and pressure of the tires all have a major impact on the handling characteristic of the motorcycle.

The tires mounted on the front and rear wheels must have a similar profile.

Worn tires have a negative effect on handling characteristics, especially on wet surfaces.

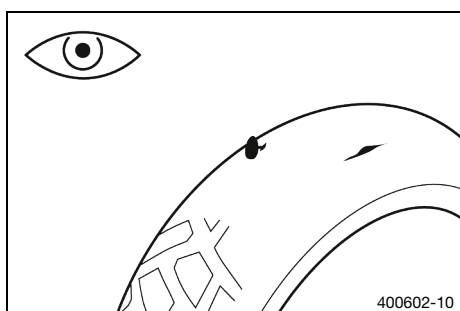

– Check the front and rear tires for cuts, run-in objects, and other damage.

» If the tires have cuts, run-in objects, or other damage:

– Change the tires. 🛠️

– Check the tread depth.

i Info

Adhere to the legally required minimum tread depth.

Minimum tread depth	$\geq 2 \text{ mm } (\geq 0.08 \text{ in})$
---------------------	---

» If the tread depth is less than the minimum tread depth:

– Change the tires. 🛠️

– Check the tire age.

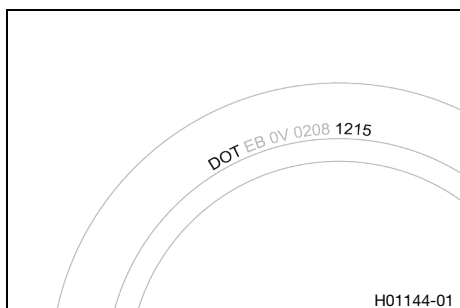

i Info

The tire date of manufacture is usually contained in the tire label and is indicated by the last four digits of the **DOT** number. The first two digits indicate the week of manufacture and the last two digits the year of manufacture.

Husqvarna Motorcycles recommends that the tires be changed after 5 years at the latest, regardless of the actual state of wear.

» If the tires are more than 5 years old:

– Change the tires. 🛠️

14.6 Checking tire pressure

i Info

Low tire pressure leads to abnormal wear and overheating of the tire.

Correct tire pressure ensures optimal riding comfort and maximum tire service life.

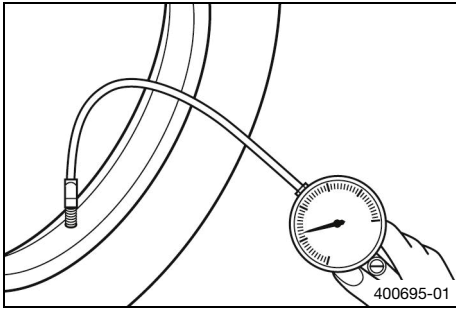

- Remove the protection cap.
- Check the tire pressure when the tires are cold.

Offroad tire pressure	
front	1.0 bar (15 psi)
rear	1.0 bar (15 psi)

Street tire pressure (TE 150i EU)	
front	1.5 bar (22 psi)
rear	1.8 bar (26 psi)

- » If the tire pressure does not meet specifications:
 - Correct the tire pressure.
- Mount the protection cap.



14.7 Checking spoke tension



Warning

Danger of accidents Incorrectly tensioned spokes impair the handling characteristic and result in secondary damage.

The spokes break due to being overloaded if they are too tightly tensioned. If the tension in the spokes is too low, then lateral and radial run-out will form in the wheel. Other spokes will become looser as a result.

- Check spoke tension regularly, and in particular on a new vehicle. (Your authorized Husqvarna Motorcycles workshop will be glad to help.)

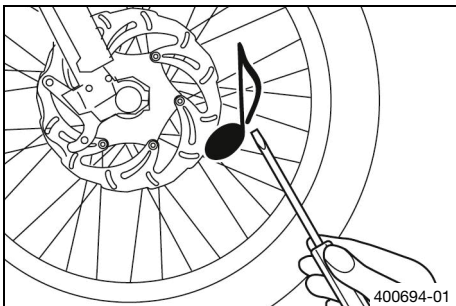

- Strike each spoke briefly using a screwdriver blade.



Info

The frequency of the sound depends on the spoke length and spoke diameter. If you hear different tone frequencies from different spokes of equal length and diameter, this is an indication of different spoke tensions.

You should hear a high note.

- » If the spoke tension differs:
 - Correct the spoke tension. 🛠️
- Check the spoke torque.

Guideline

Spoke nipple, front wheel	M4.5	6 Nm (4.4 lbf ft)
Spoke nipple, rear wheel	M4.5	6 Nm (4.4 lbf ft)

Torque wrench kit (58429094000)



15.1 Removing the 12-V battery



Note

Environmental hazard 12 V batteries contain environmentally hazardous materials.

- Do not dispose of 12 V batteries as household waste.
- Dispose of 12 V batteries at a collection point for used batteries.



Note

Environmental hazard Hazardous substances cause environmental damage.

- Dispose of oils, grease, filters, fuel, cleaning agents, brake fluid, etc., correctly and in compliance with the applicable regulations.

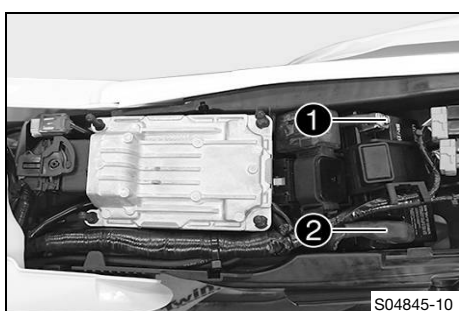

Preparatory work

- Remove the air filter box cover. (📖 p. 69)
- Remove the seat. (📖 p. 68)

Main work



Warning

Risk of injury 12 V batteries contain harmful substances.

- Keep 12 V batteries out of the reach of children.
- Keep sparks and open flames away from 12 V batteries.
- Only charge 12 V batteries in well-ventilated rooms.
- Maintain a minimum clearance from inflammable materials when charging 12 V batteries.
Minimum clearance 1 m (3 ft)
- Do not charge deeply discharged 12 V batteries if the charge is already below the minimum voltage.
Minimum voltage 9 V before the start of the charge
- Dispose of 12 V batteries with less than the minimum voltage correctly.

- Disconnect negative cable ① from the 12-V battery.
- Pull back positive terminal cover ② and disconnect the positive cable from the 12-V battery.
- Pull EFI control unit ③ upward off rubber lugs ④ and hang to the side.

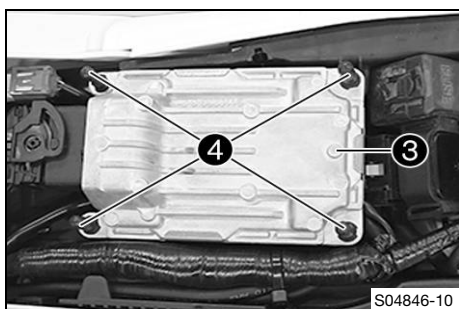

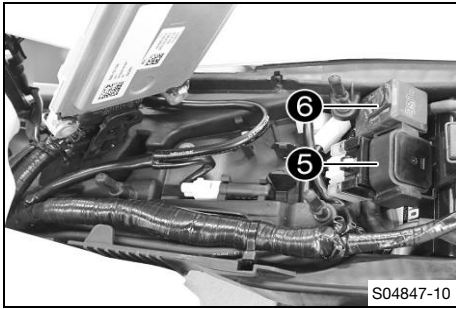

- Pull off starter relay ⑤ and fuse box ⑥ from the battery compartment and hang to the side.

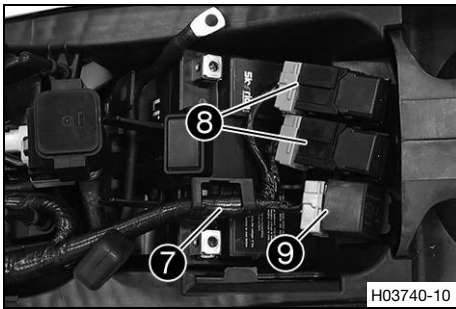

- Detach wiring harness ⑦, disconnect relays ⑧ and plug ⑨, and hang to the side.

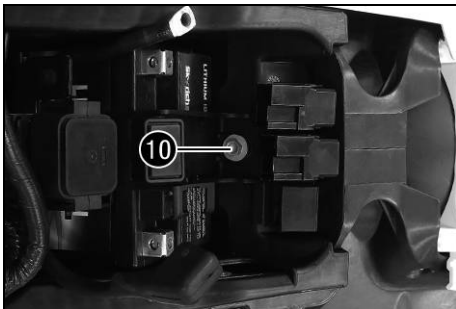

- Remove screw ⑩ and detach the battery compartment.
- Lift out the 12-V battery.



15.2 Installing the 12-V battery

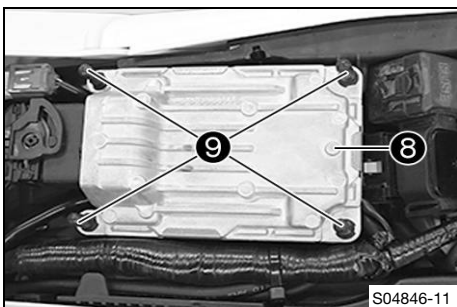
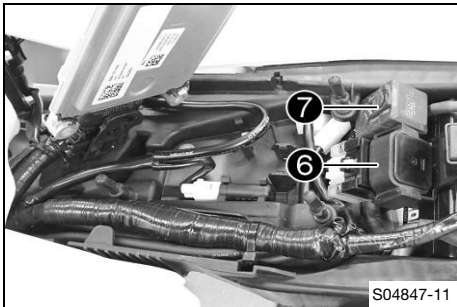
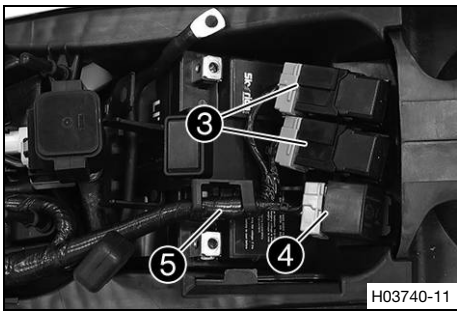
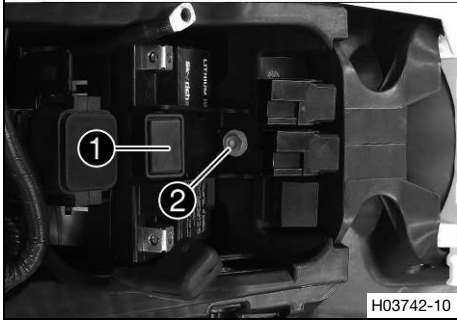

Main work

- Insert the 12-V battery into the battery compartment with the terminals facing forward and secure with holding bracket **1**.

12-V battery (HJTZ5S-FP-C) (p. 150)

- Mount and tighten screw **2**.

Guideline

Remaining screws, chassis	M6	10 Nm (7.4 lbf ft)
---------------------------	----	--------------------

- Place relays **3** and connector **4** on the battery compartment and attach the wiring harness **5**.

- Attach starter relay **6** and fuse box **7** to the battery compartment.

- Secure EFI control unit **8** with the rubber lugs **9**.

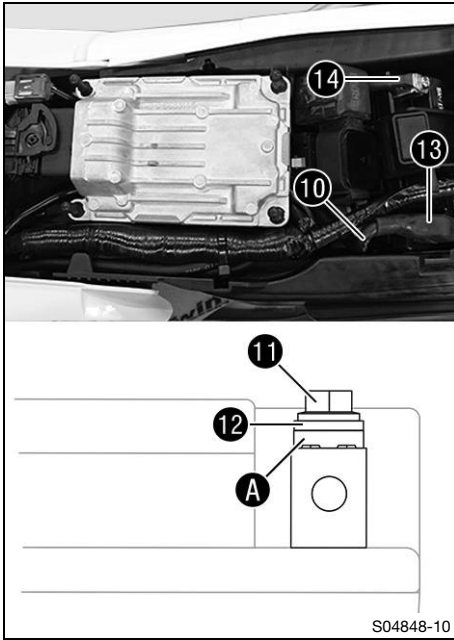

- Connect positive cable 10 to the 12-V battery.

Guideline

Screw, battery terminal	M5	2.5 Nm (1.84 lbf ft)
-------------------------	----	----------------------

i Info
Contact disk A must be mounted under screw 11 and cable lug 12 with the claws toward the battery terminal.

- Slide positive terminal cover 13 over the positive terminal.
- Connect negative cable 14 to the 12-V battery.

Guideline

Screw, battery terminal	M5	2.5 Nm (1.84 lbf ft)
-------------------------	----	----------------------

i Info
Contact disk A must be mounted under screw 11 and cable lug 12 with the claws toward the battery terminal.

Finishing work

- Mount the seat. (📖 p. 68)
- Install the air filter box cover. (📖 p. 69)

15.3 Charging the 12-V battery ↩



Warning

Risk of injury 12 V batteries contain harmful substances.

- Keep 12 V batteries out of the reach of children.
- Keep sparks and open flames away from 12 V batteries.
- Only charge 12 V batteries in well-ventilated rooms.
- Maintain a minimum clearance from inflammable materials when charging 12 V batteries.
Minimum clearance 1 m (3 ft)
- Do not charge deeply discharged 12 V batteries if the charge is already below the minimum voltage.
Minimum voltage before the start of the charge 9 V
- Dispose of 12 V batteries with less than the minimum voltage correctly.



Note

Environmental hazard 12 V batteries contain environmentally hazardous materials.

- Do not dispose of 12 V batteries as household waste.
- Dispose of 12 V batteries at a collection point for used batteries.



Note

Environmental hazard Hazardous substances cause environmental damage.

- Dispose of oils, grease, filters, fuel, cleaning agents, brake fluid, etc., correctly and in compliance with the applicable regulations.

i Info

Even when there is no load on the 12-V battery, it discharges steadily each day. The charging level and the method of charging are very important for the service life of the 12-V battery. Rapid recharging with a high charging current shortens the service life of the battery. If the charging current or charging voltage are exceeded, the 12-V battery will be destroyed. If the 12-V battery is depleted by repeated starting, the 12-V battery must be charged immediately. If the 12-V battery is left in a discharged state for an extended period, it will become deeply discharged and suffer a loss of capacity, destroying the battery. The 12-V battery is maintenance-free.

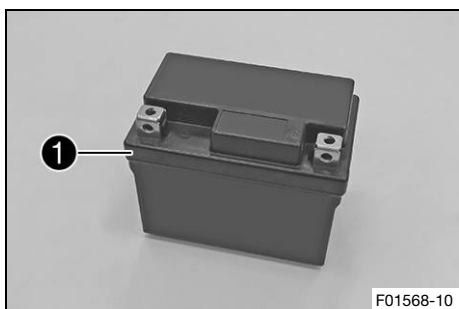

Preparatory work

- Remove the air filter box cover. (📖 p. 69)
- Remove the seat. (📖 p. 68)
- Remove the 12-V battery. 🛠️ (📖 p. 104)

Main work

- Check the battery voltage.
 - » Battery voltage: < 9 V
 - Do not charge the 12-V battery.
 - Replace the 12-V battery and dispose of the old 12-V battery properly.
 - » If the specifications have been met:
 - Battery voltage: ≥ 9 V
 - Charge the 12-V battery.

Guideline

Maximum charging voltage	14.4 V
Maximum charging current	3.0 A
Maximum charging time	24 h
Recharge the 12-V battery regularly when the motorcycle is not being used	6 months

Battery charger (26529974000)

This battery charger tests whether the 12-V battery retains its voltage. It is also impossible to overcharge the 12-V battery with this battery charger. The charging time may be longer at low temperatures.

This battery charger is only suitable for lithium iron phosphate batteries. Observe the accompanying instructions for Husqvarna Motorcycles technical accessories.

i Info

Never remove cover ❶.

- Switch off the battery charger after charging and disconnect from the 12-V battery.

Finishing work

- Install the 12-V battery. 🛠️ (📖 p. 106)
- Mount the seat. (📖 p. 68)

- Install the air filter box cover. (📖 p. 69)



15.4 Changing main fuse



Warning

Fire hazard Incorrect fuses overload the electrical system.

- Only use fuses with the required ampere value.
- Do not bypass or repair fuses.



Info

The main fuse protects all electrical power consumers of the vehicle.

Preparatory work

- Remove the air filter box cover. (📖 p. 69)
- Remove the seat. (📖 p. 68)

Main work

- Pull EFI control unit **1** upward off the rubber lugs **2** and hang to the side.

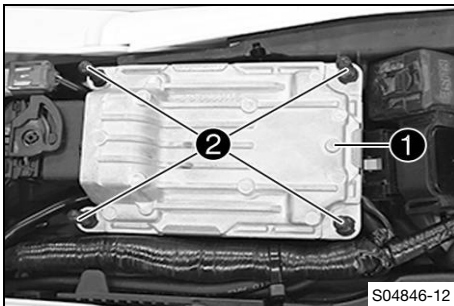

- Pull starter relay **3** from the holder.

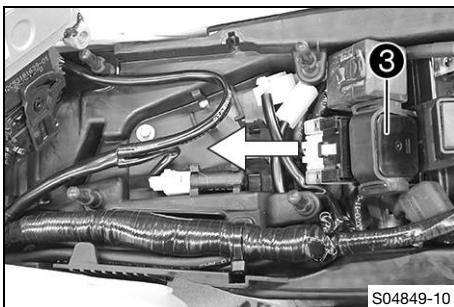

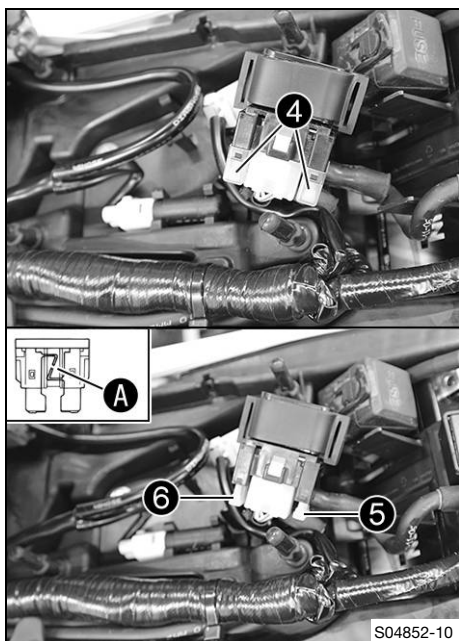

- Take off protection caps ④.
- Remove faulty main fuse ⑤.

i Info

A faulty fuse has a burned-out fuse wire **A**.
A spare fuse ⑥ is located in the starter relay.

- Insert a new main fuse.

Fuse (58011109120) (📖 p. 150)

- Check that the electrical system is functioning properly.

i Tip

Insert a spare fuse so that it is available if needed.

- Attach the protection caps ④.
- Mount starter relay ③ onto the holder and route the cable.

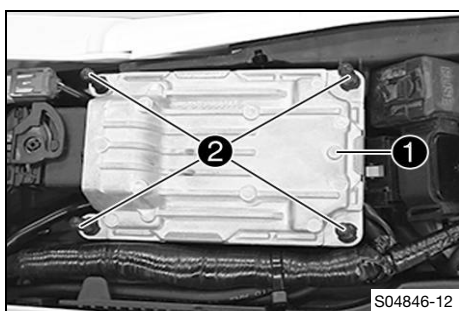

- Mount the EFI control unit ① on the rubber lugs ②.

Finishing work

- Mount the seat. (📖 p. 68)
- Install the air filter box cover. (📖 p. 69)

15.5 Changing the fuses of individual electrical power consumers

i Info

The fuse box containing the fuses of individual electrical power consumers is located under the seat.

Preparatory work

- Remove the air filter box cover. (📖 p. 69)
- Remove the seat. (📖 p. 68)

Main work

- Open fuse box cover ①.
- Remove the faulty fuse.

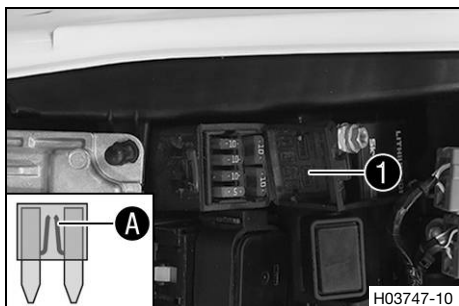

Guideline

(TE 150i EU)

Fuse 1 - 10 A - EFI control unit, lambda sensor, oil pump, combination instrument, electronic fuel injection, diagnostics connector, ignition coil, oil level sensor
--

Fuse 2 - 10 A - horn, brake light, radiator fan (optional), turn signal

Fuse 3 - 10 A - high beam, low beam, position light, tail light, license plate lamp

Fuse 4 - 5 A - fuel pump

(TE 150i US)

Fuse 1 - 10 A - EFI control unit, oil pump, combination instrument, electronic fuel injection, diagnostics connector, ignition coil, oil level sensor

Fuse 2 - 10 A - radiator fan (optional)

Fuse 3 - 10 A - low beam, position light, tail light
--

Fuse 4 - 5 A - fuel pump

Fuses res - 10 A - spare fuse

**Info**

A faulty fuse has a burned-out fuse wire .

**Warning**

Fire hazard Incorrect fuses overload the electrical system.

- Only use fuses with the required ampere value.
- Do not bypass or repair fuses.

- Insert the spare fuse with the correct rating.

Fuse (75011088010)  p. 150



Fuse (75011088005)  p. 150

**Tip**

Put a spare fuse in the fuse box so that it is available if needed.

- Check the function of the electrical power consumer.
- Close the fuse box cover .

Finishing work

- Mount the seat.  p. 68
- Install the air filter box cover.  p. 69



15.6 Removing the headlight mask with the headlight

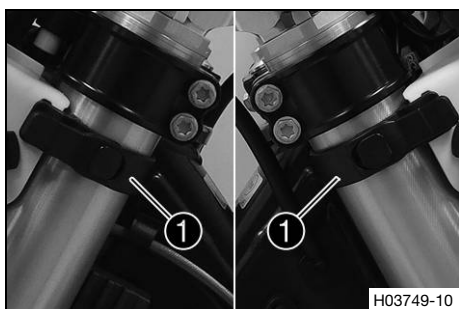

- Loosen rubber straps **1**. Push the headlight mask upwards and pivot it to the right.

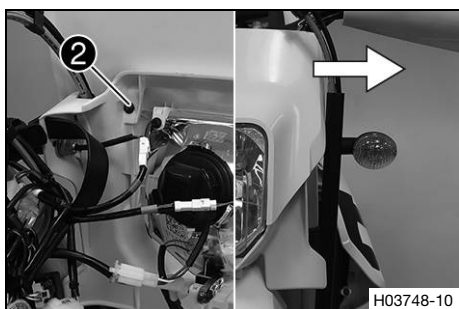

- Remove screw **2**.
- Detach the brake line and wiring harness from the headlight mask.
- Pivot the headlight mask forwards and place it on the fender.



(TE 150i EU)

- Detach plug-in connectors **3** and take off the headlight mask with the headlight.



(TE 150i US)

- Disconnect plug-in connector **3** and take off the headlight mask together with the headlight.

15.7 Installing the headlight mask with the headlight

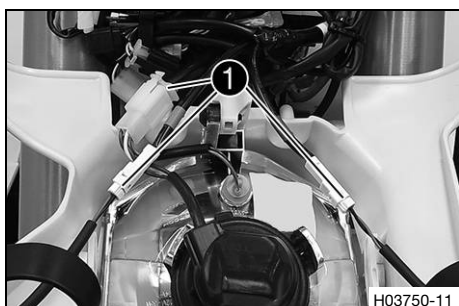

Main work (TE 150i EU)

- Join plug-in connectors **1**.

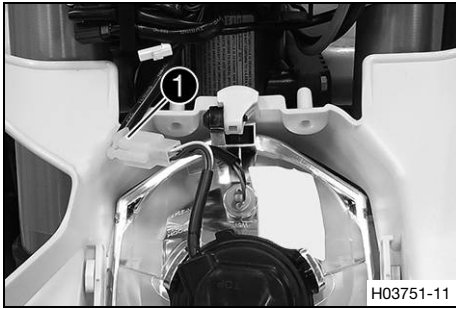

(TE 150i US)

- Join plug-in connector ①.



- Position the brake line and the wiring harness in the cable guide.
- Mount and tighten screw ②.
- Position the headlight mask.
- ✓ The holding lugs engage in the fender.

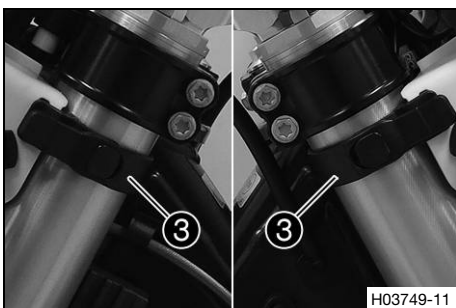

- Secure the headlight mask with rubber straps ③.

Finishing work

- Check the headlight setting. (📖 p. 115)



15.8 Changing the headlight bulb

Note

Damage to reflector Grease on the reflector reduces the light intensity.

Grease on the bulb will evaporate due to the heat and be deposited on the reflector.

- Clean and degrease the bulbs before mounting.
- Do not touch the bulbs with your bare hands.

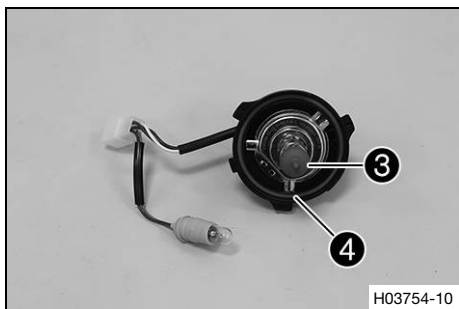
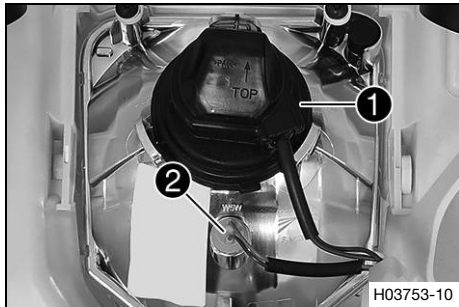

Preparatory work

- Remove the headlight mask with the headlight. (📖 p. 112)

Main work

- Turn protection cap ① together with the underlying bulb socket counterclockwise all the way and remove it.
- Pull bulb socket ② of the position light out of the reflector.

- Pull out headlight bulb ③.

- Insert the new headlight bulb.

Headlight (HS1/socket BX43t) (📖 p. 150)

- Insert the protection cap with the bulb socket into the reflector and turn it clockwise all the way.

✓ O-ring ④ is correctly positioned.

- Insert the bulb socket of the position light into the reflector.

Finishing work

- Install the headlight mask with the headlight. (📖 p. 112)
- Check the headlight setting. (📖 p. 115)

15.9 Changing the turn signal bulb (TE 150i EU)

Note

Damage to reflector Grease on the reflector reduces the light intensity.

Grease on the bulb will evaporate due to the heat and be deposited on the reflector.

- Clean and degrease the bulbs before mounting.
- Do not touch the bulbs with your bare hands.

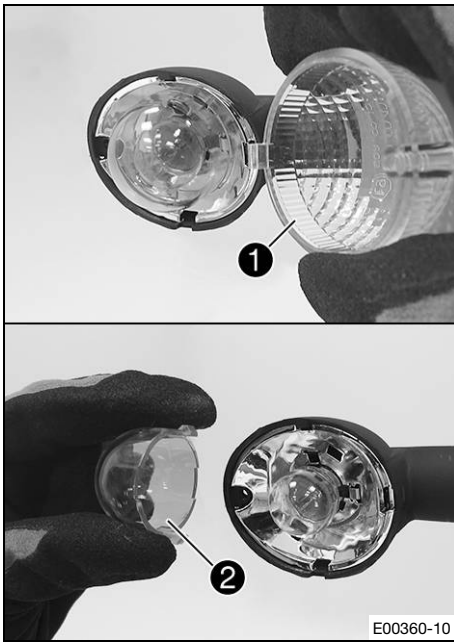
**Main work**

- Remove the screw on the rear of the turn signal housing.
- Carefully remove turn signal glass ①.
- Lightly squeeze orange cap ② in the area of the holding lugs and take it off.
- Press the turn signal bulb lightly into the socket, turn it counterclockwise by about 30°, and take it out of the socket.

i Info

Do not touch the reflector with your fingers and keep it free from grease.

- Press the new turn signal bulb carefully into the socket and turn it clockwise until it stops.

Turn signal (R10W/socket BA15s) (📖 p. 150)
--

- Mount the orange cap.
- Position the turn signal glass.
- Insert the screw and first turn counterclockwise until it engages in the thread with a small jerk. Tighten the screw lightly.

Finishing work

- Check that the turn signal system is functioning properly.

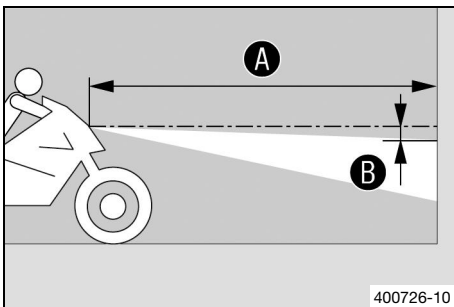
**15.10 Checking the headlight setting**

- Park the vehicle on a horizontal surface in front of a light-colored wall and make a mark at the height of the center of the low beam headlight.

- Make another mark at a distance ② under the first marking.

Guideline

Distance ②	5 cm (2 in)
------------	-------------

- Position the vehicle vertically at a distance ① away from the wall.

Guideline

Distance ①	5 m (16 ft)
------------	-------------

- The rider now sits down on the motorcycle.
- Switch on the low beam.
- Check the headlight setting.

The boundary between light and dark must be exactly on the lower mark for a motorcycle with rider.
--

- » If the boundary between light and dark does not meet specifications:

- Adjust the headlight range. (📖 p. 116)



15.11 Adjusting the headlight range

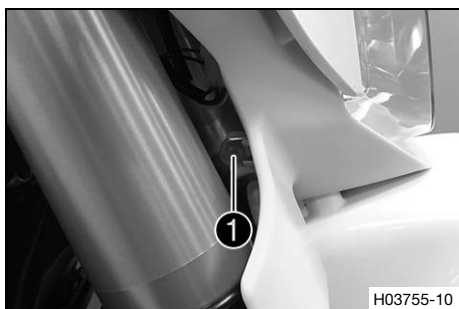

Preparatory work

- Check the headlight setting. (📖 p. 115)

Main work

- Loosen screw ❶.
- Adjust the headlight range by pivoting the headlight.

Guideline

The boundary between light and dark must be exactly on the lower mark for a motorcycle with rider (instructions on how to apply the mark: Checking the headlight setting).

Info

If you have a payload, you may have to correct the headlight range.

- Tighten screw ❶.

15.12 Changing the combination instrument battery



Preparatory work

- Remove the headlight mask with the headlight. (📖 p. 112)

Main work

- Remove screws ❶ with the washers.
- Pull the combination instrument upward out of the holder.

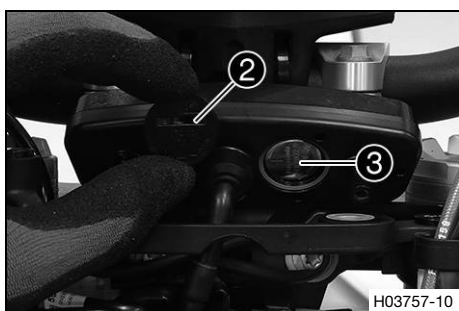

- Using a coin, turn protection cap ❷ all the way counter-clockwise and take it off.
- Remove combination instrument battery ❸.
- Insert the combination instrument battery with the label facing outward.

Combination instrument battery (CR 2032) (📖 p. 150)

- Check the O-ring of the protection cap for correct seating.

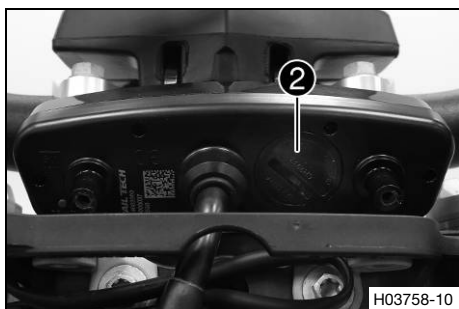

- Position protection cap ❷ and turn all the way clockwise using a coin.
- Press any button on the combination instrument.
 - ✓ The combination instrument is activated.
- Position the combination instrument in the holder.
- Mount and tighten the screws with washers.

Finishing work

- Install the headlight mask with the headlight. (📖 p. 112)
- Check the headlight setting. (📖 p. 115)
- Adjust the combination instrument. (📖 p. 26)

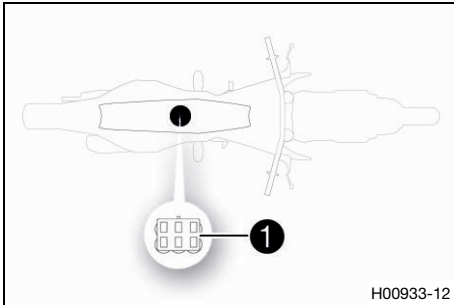
**15.13 Diagnostics connector**

The diagnostics connector **1** is located under the seat below the EFI control unit.

16.1 Cooling system

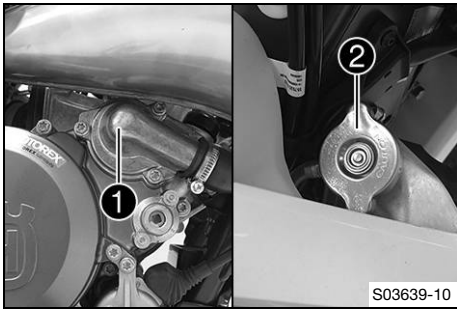

Water pump **1** in the engine ensures forced circulation of the coolant.

The pressure resulting from the warming of the cooling system is regulated by a valve in radiator cap **2**. This ensures that operating the vehicle at the specified coolant temperature will not result in a risk of malfunctions.

120 °C (248 °F)

Cooling is effected by the air stream.

The lower the speed, the less the cooling effect. Dirty cooling fins also reduce the cooling effect.

16.2 Checking the antifreeze and coolant level

Warning

Danger of scalding During motorcycle operation, the coolant gets very hot and is under pressure.

- Do not open the radiator, the radiator hoses or other cooling system components if the engine or the cooling system are at operating temperature.
- Allow the cooling system and the engine to cool down before you open the radiator, the radiator hoses or other components of the cooling system.
- In the event of scalding, rinse the area affected immediately with lukewarm water.

Warning

Danger of poisoning Coolant is toxic and a health hazard.

- Keep coolant out of the reach of children.
- Do not allow coolant to come into contact with the skin, the eyes and clothing.
- Consult a doctor immediately if coolant is swallowed.
- Rinse the affected area immediately with plenty of water in the event of contact with the skin.
- Rinse eyes thoroughly with water and consult a doctor immediately if coolant gets into the eyes.
- Change clothing if coolant spills onto your clothing.

Condition

The engine is cold.

- Stand the motorcycle upright on a horizontal surface.
- Remove the radiator cap.
- Check the antifreeze in the coolant.

-25 ... -45 °C (-13 ... -49 °F)

» If the antifreeze in the coolant does not match the specified value:

- Correct the antifreeze in the coolant.

- Check the coolant level in the radiator.

Coolant level A above the radiator fins	10 mm (0.39 in)
--	-----------------

» If the coolant level does not match the specified value:

- Correct the coolant level.

Coolant (📖 p. 155)

- Mount the radiator cap.

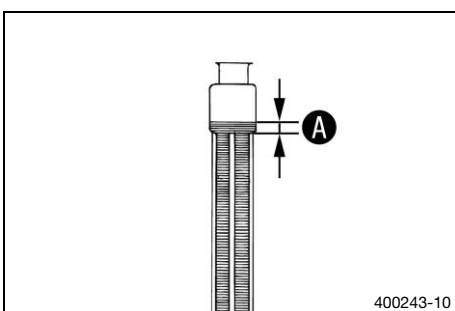

16.3 Checking the coolant level



Warning

Danger of scalding During motorcycle operation, the coolant gets very hot and is under pressure.

- Do not open the radiator, the radiator hoses or other cooling system components if the engine or the cooling system are at operating temperature.
- Allow the cooling system and the engine to cool down before you open the radiator, the radiator hoses or other components of the cooling system.
- In the event of scalding, rinse the area affected immediately with lukewarm water.



Warning

Danger of poisoning Coolant is toxic and a health hazard.

- Keep coolant out of the reach of children.
- Do not allow coolant to come into contact with the skin, the eyes and clothing.
- Consult a doctor immediately if coolant is swallowed.
- Rinse the affected area immediately with plenty of water in the event of contact with the skin.
- Rinse eyes thoroughly with water and consult a doctor immediately if coolant gets into the eyes.
- Change clothing if coolant spills onto your clothing.

Condition

The engine is cold.

- Stand the motorcycle upright on a horizontal surface.
- Remove the radiator cap.
- Check the coolant level in the radiator.

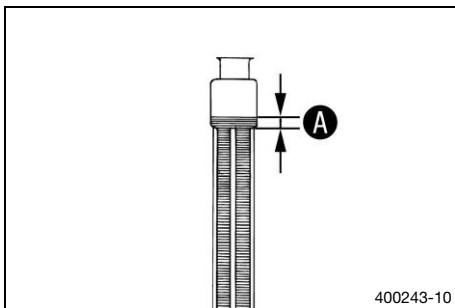

Coolant level A above the radiator fins	10 mm (0.39 in)
--	-----------------

» If the coolant level does not match the specified value:

- Correct the coolant level.

Coolant (📖 p. 155)

- Mount the radiator cap.



16.4 Draining the coolant ↴



Warning

Danger of scalding During motorcycle operation, the coolant gets very hot and is under pressure.

- Do not open the radiator, the radiator hoses or other cooling system components if the engine or the cooling system are at operating temperature.
- Allow the cooling system and the engine to cool down before you open the radiator, the radiator hoses or other components of the cooling system.
- In the event of scalding, rinse the area affected immediately with lukewarm water.



Warning

Danger of poisoning Coolant is toxic and a health hazard.

- Keep coolant out of the reach of children.
- Do not allow coolant to come into contact with the skin, the eyes and clothing.
- Consult a doctor immediately if coolant is swallowed.
- Rinse the affected area immediately with plenty of water in the event of contact with the skin.
- Rinse eyes thoroughly with water and consult a doctor immediately if coolant gets into the eyes.
- Change clothing if coolant spills onto your clothing.

Condition

The engine is cold.

- Position the motorcycle upright.
- Place an appropriate container under the water pump cover.
- Remove screw ❶. Take off radiator cap ❷.
- Completely drain the coolant.
- Mount and tighten screw ❶ with a new seal ring.

Guideline

Screw, water pump cover	M6	10 Nm (7.4 lbf ft)
-------------------------	----	--------------------

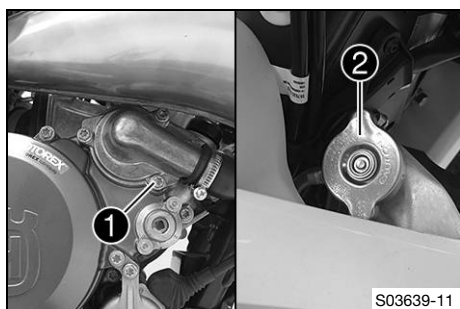

16.5 Refilling with coolant ↩



Warning

Danger of poisoning Coolant is toxic and a health hazard.

- Keep coolant out of the reach of children.
- Do not allow coolant to come into contact with the skin, the eyes and clothing.
- Consult a doctor immediately if coolant is swallowed.
- Rinse the affected area immediately with plenty of water in the event of contact with the skin.
- Rinse eyes thoroughly with water and consult a doctor immediately if coolant gets into the eyes.
- Change clothing if coolant spills onto your clothing.

Main work

- Make sure that screw ❶ is tightened.
- Position the motorcycle upright.

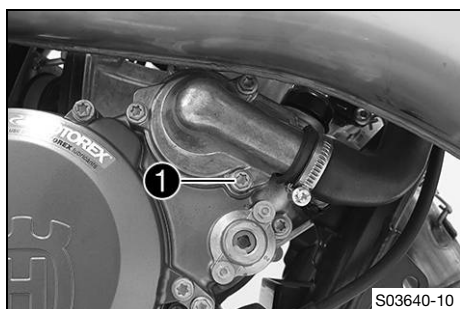

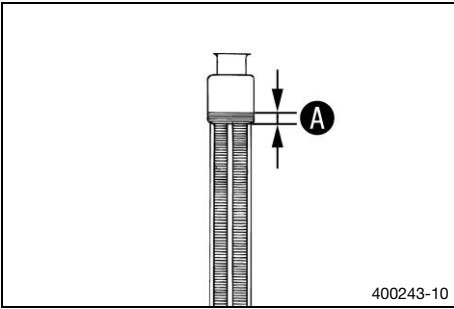

- Pour coolant in up to level **A** above the radiator fins.

Guideline

Coolant level A above the radiator fins	10 mm (0.39 in)
--	-----------------

Coolant (📖 p. 155)

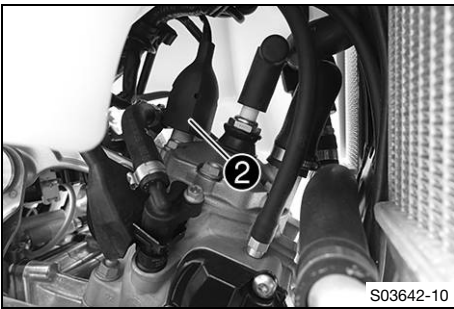

- Push protection cap **2** upward over the coolant temperature sensor.

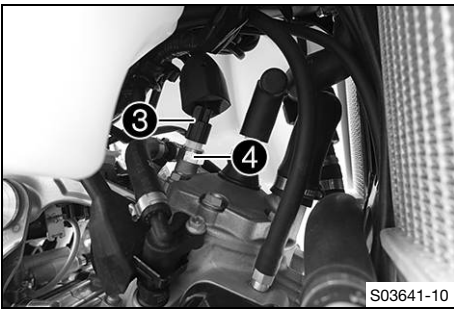

- Unplug connector **3**.
- Remove coolant temperature sensor **4** with the O-ring and wait until the coolant escapes without bubbles.
- Mount and tighten coolant temperature sensor **4** with the O-ring.

Guideline

Screw, cylinder head temperature sensor	M10x1.25	12 Nm (8.9 lbf ft)
---	----------	--------------------

- Plug in connector **3**.
- Position protection cap **2**.
- Pour coolant in up to level **A** above the radiator fins.

Guideline

Coolant level A above the radiator fins	10 mm (0.39 in)
--	-----------------

Coolant (📖 p. 155)

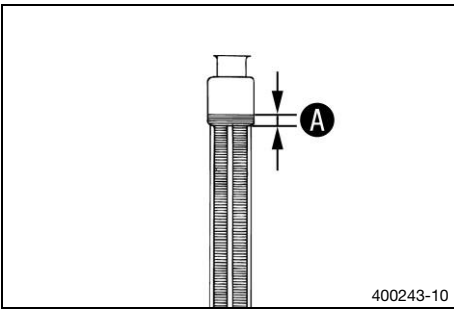

- Mount radiator cap **5**.



Danger

Danger of poisoning Exhaust gases are toxic and inhaling them may result in unconsciousness and death.

- Always make sure there is sufficient ventilation when running the engine.
- Use effective exhaust extraction when starting or running the engine in an enclosed space.

- Allow the engine to warm up and cool down again.

Finishing work

- Check the coolant level. (🔧 p. 119)

16.6 Changing the coolant 🗑️



Warning

Danger of scalding During motorcycle operation, the coolant gets very hot and is under pressure.

- Do not open the radiator, the radiator hoses or other cooling system components if the engine or the cooling system are at operating temperature.
- Allow the cooling system and the engine to cool down before you open the radiator, the radiator hoses or other components of the cooling system.
- In the event of scalding, rinse the area affected immediately with lukewarm water.



Warning

Danger of poisoning Coolant is toxic and a health hazard.

- Keep coolant out of the reach of children.
- Do not allow coolant to come into contact with the skin, the eyes and clothing.
- Consult a doctor immediately if coolant is swallowed.
- Rinse the affected area immediately with plenty of water in the event of contact with the skin.
- Rinse eyes thoroughly with water and consult a doctor immediately if coolant gets into the eyes.
- Change clothing if coolant spills onto your clothing.

Condition

The engine is cold.

- Position the motorcycle upright.
- Place an appropriate container under the water pump cover.
- Remove screw ❶. Take off radiator cap ❷.
- Completely drain the coolant.
- Mount and tighten screw ❶ with a new seal ring.

Guideline

Screw, water pump cover	M6	10 Nm (7.4 lbf ft)
-------------------------	----	--------------------

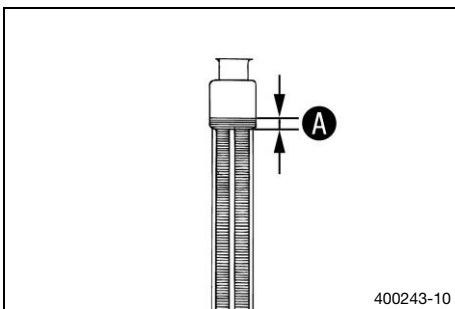
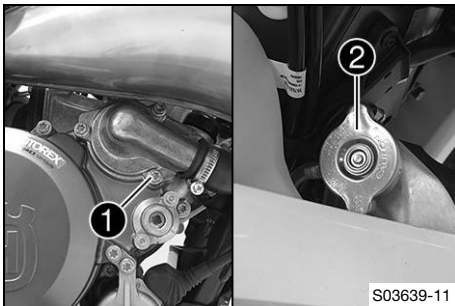

- Pour coolant in up to level A above the radiator fins.

Guideline

Coolant level A above the radiator fins	10 mm (0.39 in)
---	-----------------

Coolant (🔧 p. 155)

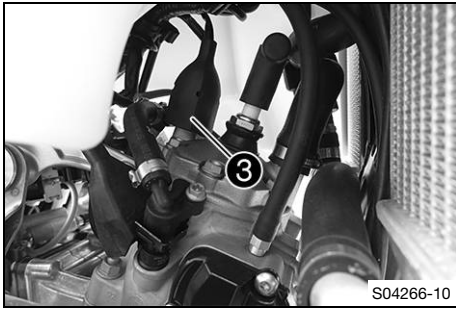

S04266-10

- Push protection cap **3** upward over the coolant temperature sensor.

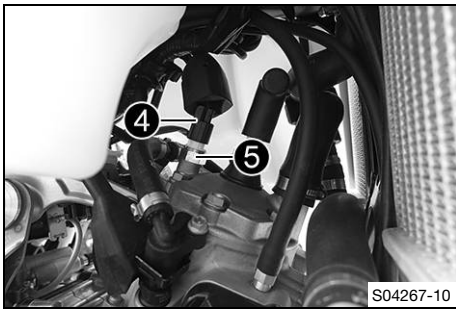

S04267-10

- Unplug connector **4**.
- Remove coolant temperature sensor **5** with the O-ring and wait until the coolant escapes without bubbles.
- Mount and tighten coolant temperature sensor **5** with the O-ring.

Guideline

Screw, cylinder head temperature sensor	M10x1.25	12 Nm (8.9 lbf ft)
---	----------	--------------------

- Plug in connector **4**.
- Position protection cap **3**.
- Pour coolant in up to level **A** above the radiator fins.

Guideline

Coolant level A above the radiator fins	10 mm (0.39 in)
--	-----------------

Coolant (📖 p. 155)

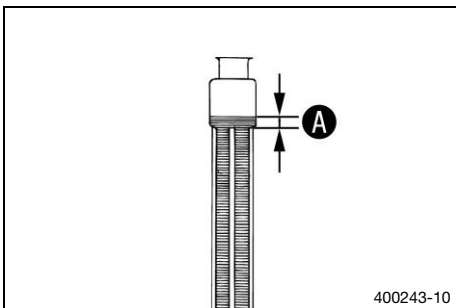

400243-10



S04268-10

- Mount radiator cap **2**.

⚠ Danger
Danger of poisoning Exhaust gases are toxic and inhaling them may result in unconsciousness and death.

- Always make sure there is sufficient ventilation when running the engine.
- Use effective exhaust extraction when starting or running the engine in an enclosed space.

- Allow the engine to warm up and cool down again.
- Check the cooling system for leaks.

Finishing work

- Check the coolant level. (📖 p. 119)



17.1 Checking the play in the throttle cable

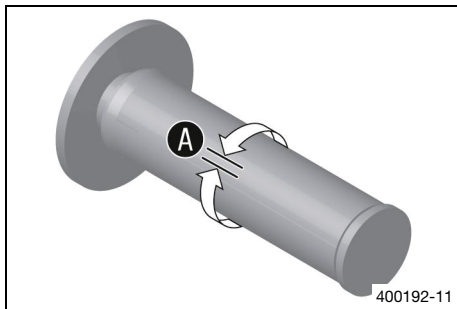

- Check the throttle grip for smooth operation.
- Turn handlebar as far as possible to the right. Turn the throttle grip back and forth slightly and determine the play in throttle cable **A**.

Play in throttle cable	3 ... 5 mm (0.12 ... 0.2 in)
------------------------	------------------------------

- » If the throttle cable play does not meet the specified value:
 - Adjust the play in the throttle cable. 🛠️ (📖 p. 124)



Danger

Danger of poisoning Exhaust gases are toxic and inhaling them may result in unconsciousness and death.

- Always make sure there is sufficient ventilation when running the engine.
- Use effective exhaust extraction when starting or running the engine in an enclosed space.

- Start the engine and let it run at idle speed. Move the handlebar to and fro over the entire steering range.

The idle speed must not change.

- » If the idle speed changes:
 - Adjust the play in the throttle cable. 🛠️ (📖 p. 124)

17.2 Adjusting the play in the throttle cable 🛠️

i Info

If the correct routing of the throttle cables has already been secured, the fuel tank does not need to be removed.

Preparatory work

- Remove the air filter box cover. (📖 p. 69)
- Remove the seat. (📖 p. 68)
- Remove the right side cover. (📖 p. 73)
- Remove the fuel tank. 🛠️ (📖 p. 74)
- Check the throttle cable routing. (📖 p. 82)

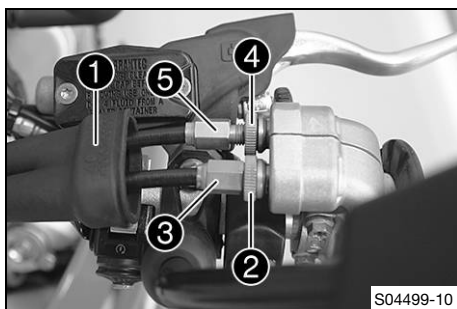

Main work

- Move the handlebar to the straight-ahead position.
- Push back sleeve **1**.
- Loosen nut **2**.
- Turn adjusting screw **3** in as far as possible.
- Loosen nut **4**.
- Turn adjusting screw **5** in as far as possible.
- Turn adjusting screw **3** so that there is play in the throttle cable at the throttle grip.

Guideline

Play in throttle cable	3 ... 5 mm (0.12 ... 0.2 in)
------------------------	------------------------------

- Unscrew the adjusting screw **5** until the smooth operation or play in throttle cable is worsened.
- Turn adjusting screw **5** approx. two turns further.
- Tighten nut **4**.
- Tighten nut **2**.
- Slide on sleeve **1**.
- Check the throttle grip for smooth operation.

Finishing work

- Check the play in the throttle cable. (📖 p. 124)



17.3 Setting the characteristic map of the throttle response ↗

Info

On the throttle grip, the characteristic map of the throttle response is changed by changing the guide plate.

A guide plate with a different characteristic map is supplied.

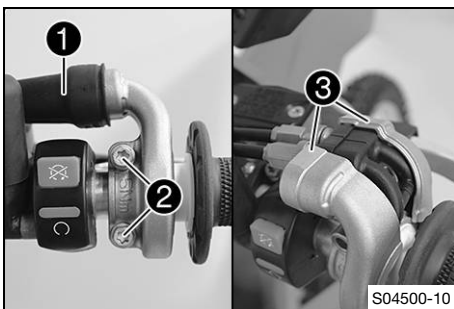

Main work

- Push back sleeve **1**.
- Remove screws **2** and half-shells **3**.
- Detach the throttle cables and take off the grip tube.

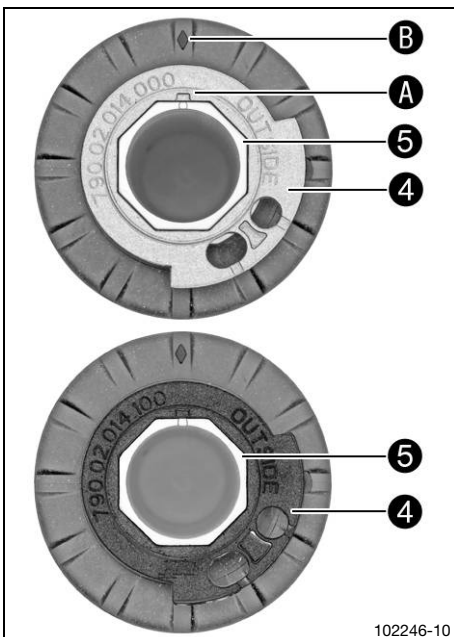

- Remove guide plate **4** from handle tube **5**.
- Position the required guide plate on the grip tube.

Guideline

The label **OUTSIDE** must be visible. Marking **A** must be positioned at marking **B**.

Grey guide plate (79002014000)

Alternative 1

Black guide plate (79002014100)

Info

The gray guide plate opens the throttle valve more slowly.

The black guide plate opens the throttle valve more quickly.

The gray guide plate is mounted upon delivery.

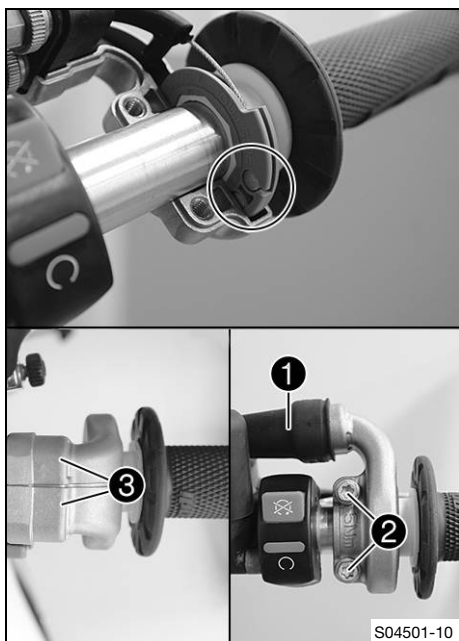

- Clean the outside of the handlebar and the inside of the grip tube. Mount the grip tube on the handlebar.
- Attach the throttle cables to the guide plate and route correctly.
- Position half-shells ③, mount and tighten screws ②.

Guideline

Screw, throttle grip	M6	5 Nm (3.7 lbf ft)
----------------------	----	-------------------

- Slide on sleeve ① and check the throttle grip for ease of movement.

Finishing work

- Check the play in the throttle cable. (📖 p. 124)

17.4 Adjusting the idle speed ↘



Warning

Danger of accidents The engine may go out spontaneously if the idle speed is set too low.

- Set the idle speed to the specified value. (Your authorized Husqvarna Motorcycles workshop will be glad to help.)

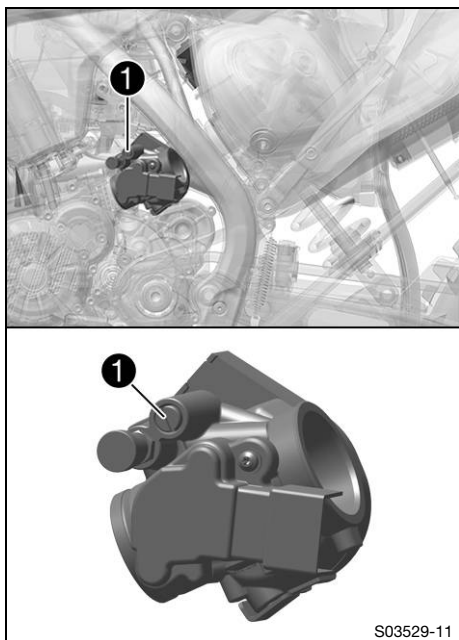

- Run the engine until warm.
- ✓ The cold start button is deactivated – A further ¼ turn returns the cold start button back to the basic position. (📖 p. 22)



Danger

Danger of poisoning Exhaust gases are toxic and inhaling them may result in unconsciousness and death.

- Always make sure there is sufficient ventilation when running the engine.
- Use effective exhaust extraction when starting or running the engine in an enclosed space.

- Adjust the idle speed by turning idle speed adjusting screw ①.

Guideline

Idle speed	1,400 ... 1,500 rpm
------------	---------------------

Tachometer (45129075000)



Info

Turn clockwise to decrease the idle speed.
 Turn counterclockwise to increase the idle speed.
 Make the setting in small steps.
 An incorrect idle speed can have a negative impact on overall engine running.



17.5 Programming ambient air pressure



Danger

Danger of poisoning Exhaust gases are toxic and inhaling them may result in unconsciousness and death.

- Always make sure there is sufficient ventilation when running the engine.
- Use effective exhaust extraction when starting or running the engine in an enclosed space.



Info

If the vehicle is ridden with the engine running at various heights above sea level, the ambient pressure is programmed on an ongoing basis.

If the vehicle is transported over great height differences, the ambient pressure must be reprogrammed.

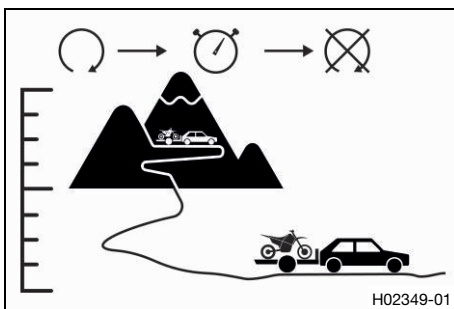

- Start up the vehicle at a new height above sea level and switch off the engine again.
- Wait for at least five seconds.
- Start the vehicle again and check the response of the vehicle.
 - » If the response has not improved:
 - Repeat the procedure.



17.6 Checking the basic position of the shift lever



Info

When driving, the shift lever must not touch the rider's boot when in the basic position.

When the shift lever keeps touching the boot, the transmission will be subject to an excessive load.

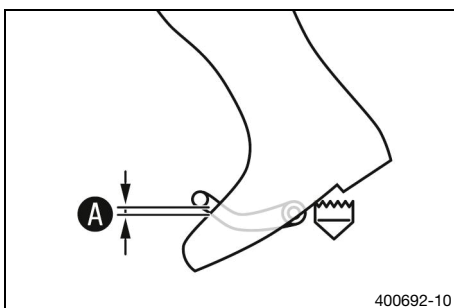

- Sit on the vehicle in the riding position and determine distance **A** between the upper edge of your boot and the shift lever.

Distance between shift lever and upper edge of boot	10 ... 20 mm (0.39 ... 0.79 in)
---	---------------------------------

- » If the distance does not meet specifications:
 - Adjust the basic position of the shift lever. (p. 128)



17.7 Adjusting the basic position of the shift lever ↩

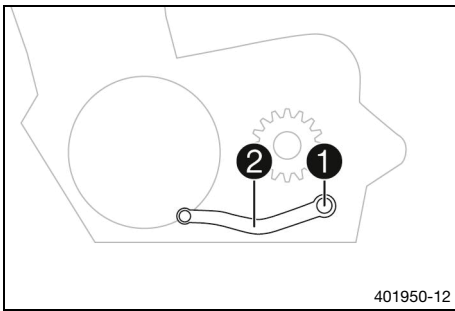

- Remove screw **1** with the washers and take off shift lever **2**.

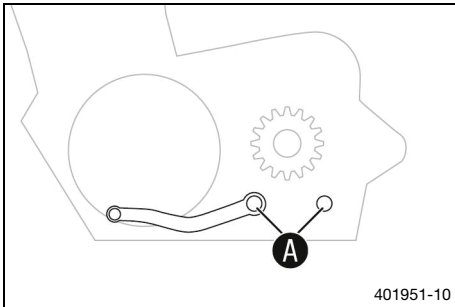

- Clean gear teeth **A** of the shift lever and shift shaft.
- Mount the shift lever on the shift shaft in the required position and engage gearing.

i Info

The range of adjustment is limited.
The shift lever must not come into contact with any other vehicle components during the shift procedure.

- Mount and tighten screw **1** with washers.

Guideline

Screw, shift lever	M6	14 Nm (10.3 lbf ft) Loctite®243™
--------------------	----	--

18.1 Changing the fuel screen



Danger

Fire hazard Fuel is highly flammable.

The fuel in the fuel tank expands when warm and can escape if overfilled.

- Do not fuel the vehicle in the vicinity of open flames or lit cigarettes.
- Switch off the engine for refueling.
- Make sure that no fuel is spilled; particularly not on hot parts of the vehicle.
- If any fuel is spilled, wipe it off immediately.
- Observe the specifications for refueling.



Warning

Danger of poisoning Fuel is poisonous and a health hazard.

- Avoid skin, eye and clothing contact with fuel.
- Immediately consult a doctor if you swallow fuel.
- Do not inhale fuel vapors.
- In case of skin contact, rinse the affected area with plenty of water.
- Rinse the eyes thoroughly with water, and consult a doctor in case of fuel contact with the eyes.
- Change your clothing in case of fuel spills on them.



Note

Environmental hazard Improper handling of fuel is a danger to the environment.

- Do not allow fuel to enter the groundwater, the soil, or the sewage system.

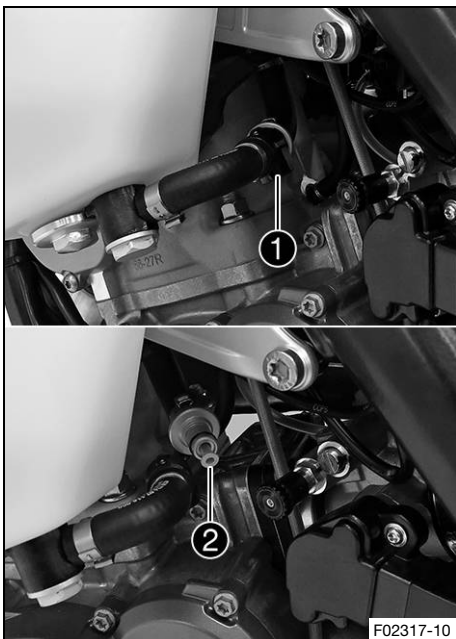

- Clean quick release coupling **1** thoroughly with compressed air.



Info

Under no circumstances should dirt enter into the fuel line. Dirt in the fuel line clogs the injection valve!

- Disconnect the quick release coupling.



Info

Remaining fuel may flow out of the fuel hose.

- Pull fuel screen **2** out of the connecting piece.
- Insert the new fuel screen all the way into the connecting piece.
- Spray silicone spray onto a lint-free cleaning cloth and lightly lubricate the O-ring of the quick-release coupling.

Silicone spray ( p. 157)

- Join the quick release coupling.



Danger

Danger of poisoning Exhaust gases are toxic and inhaling them may result in unconsciousness and death.

- Always make sure there is sufficient ventilation when running the engine.
- Use effective exhaust extraction when starting or running the engine in an enclosed space.

- Start the engine and check the response.

18.2 Checking 2-stroke oil level



Warning

Engine failure The engine will not be lubricated unless there is 2-stroke oil in the oil tank.

If the oil level warning light lights up, the 2-stroke oil is sufficient for the remaining tank of fuel.

- As soon as the oil level warning light lights up, ride for no longer than until the remaining fuel in the tank is depleted.
- At the next opportunity add 2-stroke oil before you refuel.
- Time the oil pump if the 2-stroke oil hose has been removed or the 2-stroke oil tank has been fully depleted in error.



Preparatory work

- Stand the motorcycle upright on a horizontal surface.

Main work

- Check the 2-stroke oil level in the oil tank.



Info

For one tank of fuel, the 2-stroke oil tank must be filled up to at least the upper edge **A**.

The 2-stroke oil tank must be completely filled if possible.

- » If the 2-stroke oil level is too low:
 - Add 2-stroke oil. (📖 p. 43)

18.3 Priming oil pump



Warning

Engine failure The engine will not be lubricated unless there is 2-stroke oil in the oil tank.

If the oil level warning light lights up, the 2-stroke oil is sufficient for the remaining tank of fuel.

- As soon as the oil level warning light lights up, ride for no longer than until the remaining fuel in the tank is depleted.
- At the next opportunity add 2-stroke oil before you refuel.
- Time the oil pump if the 2-stroke oil hose has been removed or the 2-stroke oil tank has been fully depleted in error.

Condition

The engine is off.

Preparatory work

- Remove the air filter box cover. (📖 p. 69)
- Remove the seat. (📖 p. 68)
- Stand the motorcycle upright on a horizontal surface.
- Check 2-stroke oil level. (📖 p. 130)

Main work

- Pull EFI control unit ① upward off the rubber lugs ② and hang to the side.
- Remove protection cap ③ of the diagnostics connector.

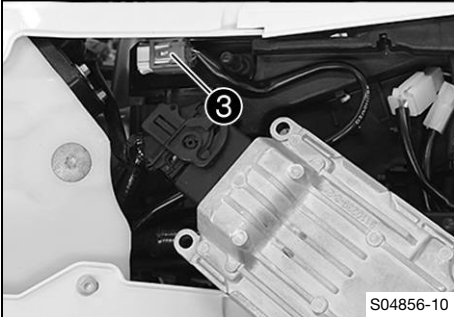
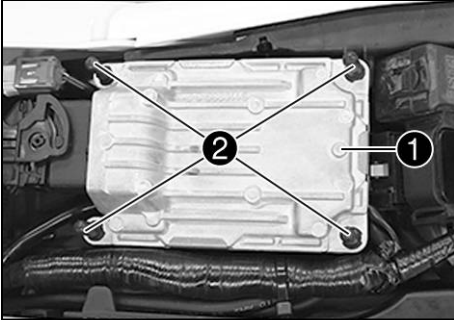

S04856-10

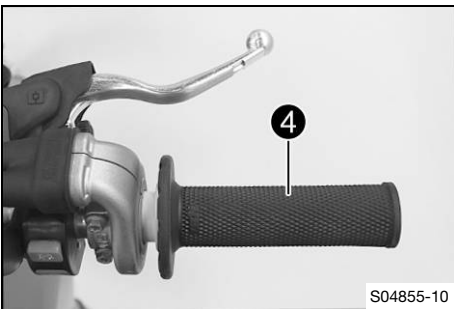

S04855-10

- Put throttle grip ④ into full throttle position and secure.

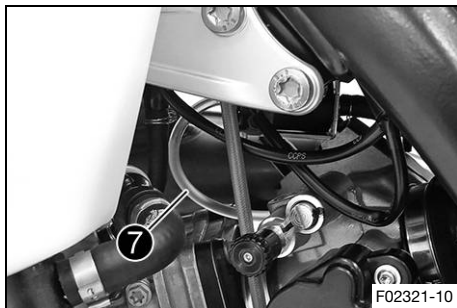
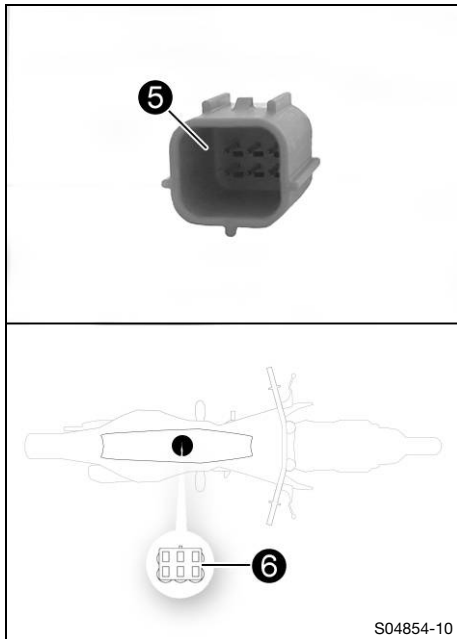

- Plug in wake-up connector **5** for priming the oil pump to the diagnostics connector **6**.

✓ The combination instrument lighting is activated.



Info

The connector is included as part of the motorcycle's separate enclosure.

- Wait for at least five seconds.
- Release the fixing means from the throttle grip.

✓ The oil pump is timed.



Info

The oil pump is actuated at various speeds. The procedure is clearly audible.

- Wait until you can no longer hear the oil pump operating.
- Disconnect the wake-up connector from the diagnostics connector.

- Check whether air bubbles are visible in the hose **7**.

» If air bubbles are visible:

- Repeat the entire procedure until air bubbles are no longer visible.

- Mount protection cap on the diagnostics connector.

- Mount the EFI control unit on the rubber lugs.

Finishing work

- Mount the seat. (📖 p. 68)
- Install the air filter box cover. (📖 p. 69)

18.4 Cleaning the oil screen in the oil tank ↴



Note

Environmental hazard Hazardous substances cause environmental damage.

- Dispose of oils, grease, filters, fuel, cleaning agents, brake fluid, etc., correctly and in compliance with the applicable regulations.

Preparatory work

- Remove main silencer. (📖 p. 71)
- Remove the air filter box cover. (📖 p. 69)
- Remove the seat. (📖 p. 68)
- Remove the right side cover. (📖 p. 73)
- Remove the fuel tank. ↴ (📖 p. 74)
- Raise the motorcycle with a lift stand. (📖 p. 56)

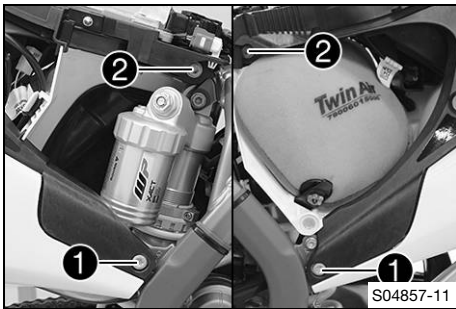

Main work

- Remove screws ①.
- Loosen screws ②.

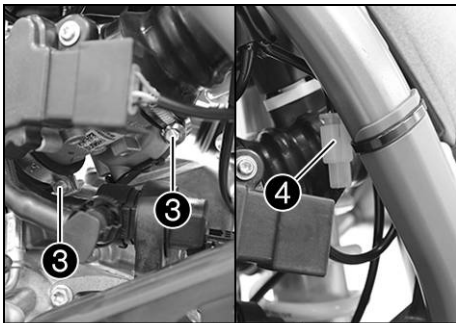

- Loosen clamps ③ of the throttle valve body.
- Disconnect plug-in connector ④ of the rear brake light switch.
- Lift the subframe slightly and secure it.

Info

Pay attention to intake flange ⑤.

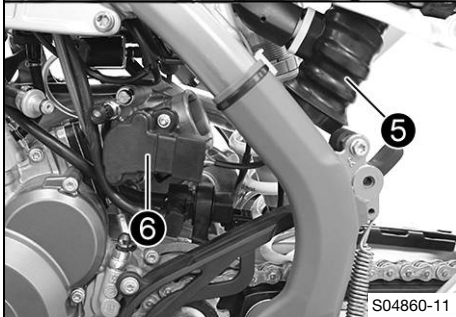

- Pull throttle valve body ⑥ towards the rear, out of the intake flange, and hang it to the side.

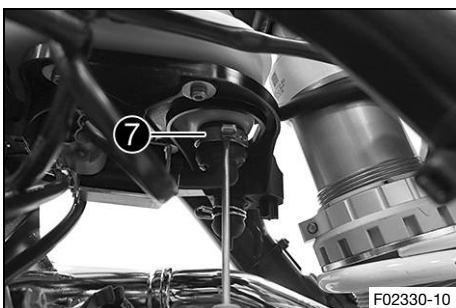

- Open hose clamp ⑦ using a screwdriver.
- Pull off the angle piece and collect the 2-stroke oil in a suitable container.

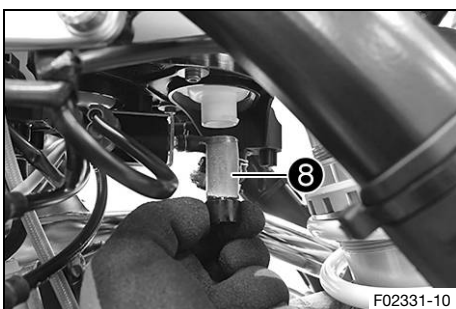

- Remove oil screen ⑧ and clean it.
- Check the oil screen for damage.
 - » If the oil screen is damaged:
 - Change the oil screen.



- Insert the oil screen and mount the angle piece with a new hose clamp.

Hose clamp pliers (60029057000)

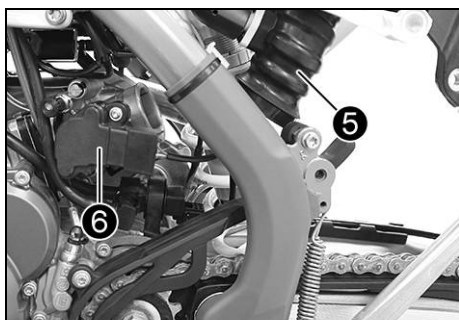

- Mount throttle valve body ⑥.
- Remove the locking piece and position the subframe.

i Info
Pay attention to intake flange ⑤.

- Join plug-in connector ④ of the rear brake light switch.
- Position and tighten clamps ③ of the throttle valve body.

Guideline

Screw, intake flange/reed valve housing	M6	6 Nm (4.4 lbf ft)
---	----	-------------------

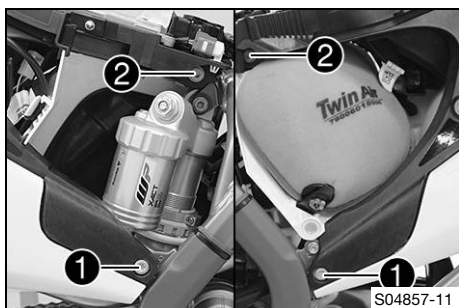
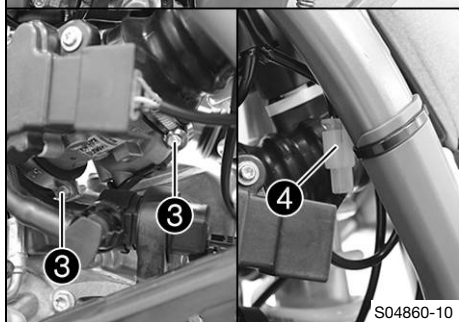

- Mount and tighten screws ①.

Guideline

Screw, sub-frame	M8	30 Nm (22.1 lbf ft) Loctite® 2701™
------------------	----	--

- Remove screws ②.
- Mount and tighten screws ②.

Guideline

Screw, sub-frame	M8	30 Nm (22.1 lbf ft) Loctite® 2701™
------------------	----	--

Finishing work

- Remove the motorcycle from the lift stand. (📖 p. 56)
- Install the fuel tank. (🔧📖 p. 75)
- Install the right side cover. (📖 p. 73)
- Add 2-stroke oil. (📖 p. 43)
- Prime the oil pump. (🔧📖 p. 130)
- Mount the seat. (📖 p. 68)
- Install the air filter box cover. (📖 p. 69)
- Install the main silencer. (📖 p. 72)

18.5 Checking the gear oil level

i Info

The gear oil level must be checked when the engine is cold.

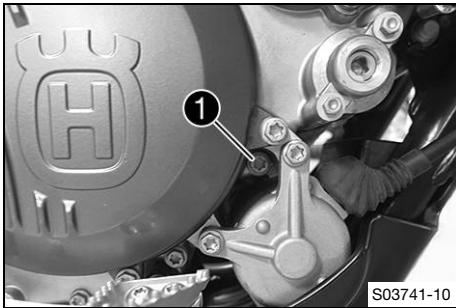

Preparatory work

- Stand the motorcycle upright on a horizontal surface.

Main work

- Remove gear oil level monitoring screw ①.
- Check the gear oil level.

A small quantity of gear oil must run out of the drilled hole.

» If no gear oil runs out:

- Add the gear oil. 🛠️ (p. 136)

- Mount and tighten the gear oil level monitoring screw.

Guideline

Screw, gear oil level monitoring	M6	8 Nm (5.9 lbf ft)
----------------------------------	----	-------------------



18.6 Changing the gear oil 🛠️



Warning

Danger of scalding Engine and gear oil get very hot when the motorcycle is ridden.

- Wear suitable protective clothing and safety gloves.
- In the event of scalding, rinse the area affected immediately with lukewarm water.



Note

Environmental hazard Hazardous substances cause environmental damage.

- Dispose of oils, grease, filters, fuel, cleaning agents, brake fluid, etc., correctly and in compliance with the applicable regulations.

i Info

Drain the gear oil while the engine is at operating temperature.

Preparatory work

- Remove the engine guard. (📖 p. 86)
- Park the motorcycle on a level surface.
- Position an appropriate container under the engine.

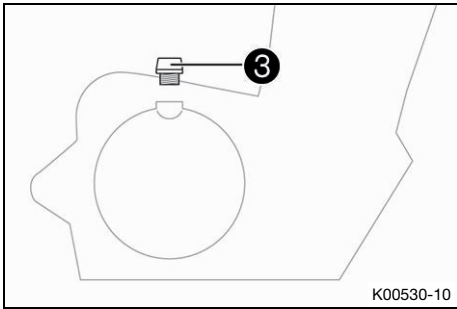
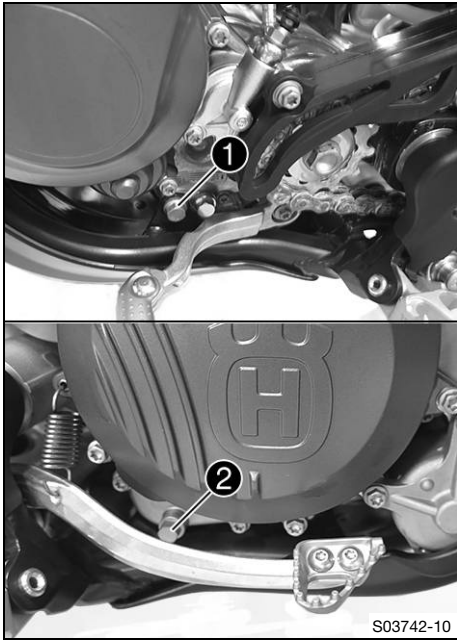

Main work

- Remove gear oil drain plug ① with magnet.
- Remove gear oil drain plug ②.
- Let the gear oil drain fully.
- Thoroughly clean the gear oil drain plug with magnet.
- Clean the sealing surface on the engine.
- Mount and tighten gear oil drain plug ① with the magnet and a new seal ring.

Guideline

Gear oil drain plug with magnet	M12x1.5	20 Nm (14.8 lbf ft)
---------------------------------	---------	---------------------

- Mount and tighten gear oil drain plug ② with a new seal ring.

Guideline

Gear oil drain plug	M10x1	15 Nm (11.1 lbf ft)
---------------------	-------	---------------------

- Remove filler plug ③ with the O-ring, and fill up with gear oil.

Gear oil	0.80 l (0.85 qt.)	Engine oil (15W/50) (p. 155)
----------	----------------------	---------------------------------

- Mount and tighten the filler plug together with the O-ring.



Danger

Danger of poisoning Exhaust gases are toxic and inhaling them may result in unconsciousness and death.

- Always make sure there is sufficient ventilation when running the engine.
- Use effective exhaust extraction when starting or running the engine in an enclosed space.

- Start the engine and check it for leaks.

Finishing work

- Check the gear oil level. (p. 135)
- Install the engine guard. (p. 86)

18.7 Adding the gear oil ↗



Info

Too little gear oil or poor-quality gear oil results in premature wear to the transmission. Gear oil must only be topped up when the engine is cold.

Preparatory work

- Park the motorcycle on a level surface.

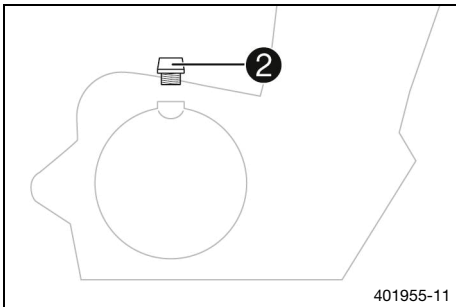
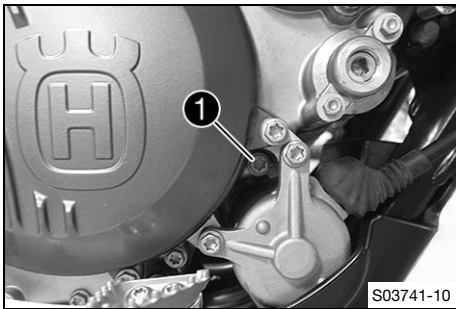

Main work

- Remove gear oil level monitoring screw ①.

- Remove filler plug ② with the O-ring.
- Add gear oil until it emerges from the drill hole of the gear oil level monitoring screw.

Engine oil (15W/50) (📖 p. 155)

- Mount and tighten the gear oil level monitoring screw.

Guideline

Screw, gear oil level monitoring	M6	8 Nm (5.9 lbf ft)
----------------------------------	----	-------------------

- Mount and tighten filler plug ② with the O-ring.



Danger

Danger of poisoning Exhaust gases are toxic and inhaling them may result in unconsciousness and death.

- Always make sure there is sufficient ventilation when running the engine.
- Use effective exhaust extraction when starting or running the engine in an enclosed space.

- Start the engine and check it for leaks.



19.1 Cleaning the motorcycle

Note

Material damage Components become damaged or destroyed if a pressure cleaner is used incorrectly. The high pressure forces water into the electrical components, connectors, throttle cables, and bearings, etc. Pressure which is too high causes malfunctions and destroys components.

- Do not direct the water jet directly on to electrical components, connectors, throttle cables or bearings.
- Maintain a minimum distance between the nozzle of the pressure cleaner and the component.

Minimum clearance 60 cm (23.6 in)



Note

Environmental hazard Hazardous substances cause environmental damage.

- Dispose of oils, grease, filters, fuel, cleaning agents, brake fluid, etc., correctly and in compliance with the applicable regulations.



Info

To maintain the value and appearance of the motorcycle over a long period, clean it regularly. Avoid direct sunshine when cleaning the motorcycle.

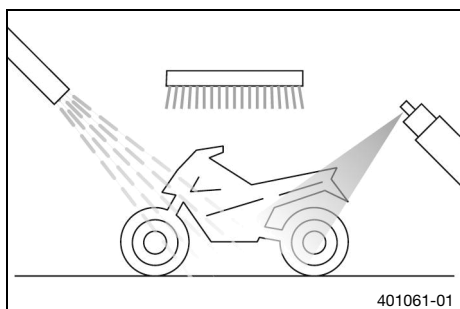

- Close off exhaust system to keep water from entering.
- Remove the coarse dirt particles with a gentle water jet.
- Spray the heavily soiled parts with a normal commercial motorcycle cleaner and clean using a brush.

Motorcycle cleaner (📖 p. 157)



Info

Use warm water containing normal motorcycle cleaner and a soft sponge. Never apply motorcycle cleaner to a dry vehicle; always rinse the vehicle with water first.

- After rinsing the motorcycle with a gentle spray of water, allow it to dry thoroughly.
- Remove the closure of the exhaust system.



Warning

Danger of accidents Moisture and dirt impair the brake system.

- Brake carefully several times to dry out and remove dirt from the brake linings and the brake discs.

- After cleaning, ride the vehicle a short distance until the engine warms up.



Info

The heat produced causes water at inaccessible locations in the engine and on the brake system to evaporate.

- After the motorcycle has cooled down, lubricate all moving parts and pivot points.
- Clean the chain. (📖 p. 77)
- Treat bare metal (except for brake discs and the exhaust system) with a corrosion inhibitor.

Preserving materials for paints, metal and rubber (📖 p. 157)

- Treat all plastic parts and powder-coated parts with a mild cleaning and care product.

Special cleaner for glossy and matte paint finishes, metal and plastic surfaces (📖 p. 158)

(TE 150i EU)

- Oil the steering lock.

Universal oil spray (📖 p. 158)



19.2 Checks and maintenance steps for winter operation

i Info

If you use the motorcycle in winter, salt can be expected on the roads. You should therefore take precautions against aggressive road salt. If the vehicle has been used on salted roads, use cold water for cleaning after riding. Warm water enhances the corrosive effects of salt.

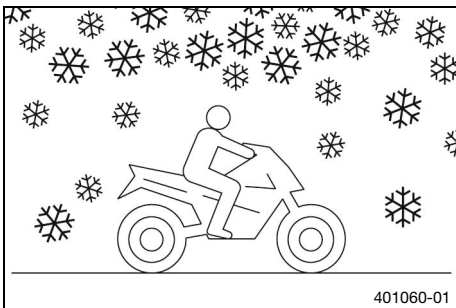

- Clean the motorcycle. (📖 p. 138)
- Clean the brakes.

i Info

After **EVERY** trip on salted roads, thoroughly clean the brake calipers and brake linings, after they have cooled down and without removing them, with cold water and dry them carefully. After riding on salted roads, thoroughly clean the vehicle with cold water and dry it well.

- Treat the engine, link fork, and all other bare or zinc-plated parts (except the brake discs) with a wax-based corrosion inhibitor.

i Info

Corrosion inhibitor must not come in contact with the brake discs as this would greatly reduce the braking force.

- Clean the chain. (📖 p. 77)



20.1 Storage



Warning

Danger of poisoning Fuel is poisonous and a health hazard.

- Avoid skin, eye and clothing contact with fuel.
- Immediately consult a doctor if you swallow fuel.
- Do not inhale fuel vapors.
- In case of skin contact, rinse the affected area with plenty of water.
- Rinse the eyes thoroughly with water, and consult a doctor in case of fuel contact with the eyes.
- Change your clothing in case of fuel spills on them.
- Keep fuels correctly in a suitable canister, and out of the reach of children.



Info

If you plan to garage the motorcycle for a longer period, perform the following steps or have them performed.

Before storing the motorcycle, check all parts for function and wear. If service, repairs, or replacements are necessary, you should do this during the storage period (less workshop overload). In this way, you can avoid long workshop waiting times at the start of the new season.

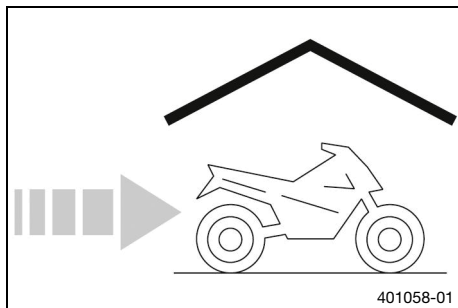

- Clean the motorcycle. (📖 p. 138)
- Change the gear oil. 🛠️ (📖 p. 135)
- Check the antifreeze and coolant level. (📖 p. 118)
- When refueling for the last time before taking the motorcycle out of service, add fuel additive.
- Refuel. (📖 p. 42)
- Check tire pressure. (📖 p. 102)
- Remove the 12-V battery. 🛠️ (📖 p. 104)
- Charge the 12-V battery. 🛠️ (📖 p. 107)

Guideline

Ideal charging and storage temperature of the lithium-ion battery	10 ... 20 °C (50 ... 68 °F)
---	-----------------------------

- Store the vehicle in a dry location that is not subject to large fluctuations in temperature.



Info

Husqvarna Motorcycles recommends raising the motorcycle.

- Raise the motorcycle with a lift stand. (📖 p. 56)
- Cover the vehicle with a tarp or a similar cover that is permeable to air.

**Info**

Do not use non-porous materials since they prevent humidity from escaping, thus causing corrosion. Avoid running the engine for a short time only. Because the engine will not warm up sufficiently, the water vapor produced during combustion will condense, causing engine parts and the exhaust system to rust.

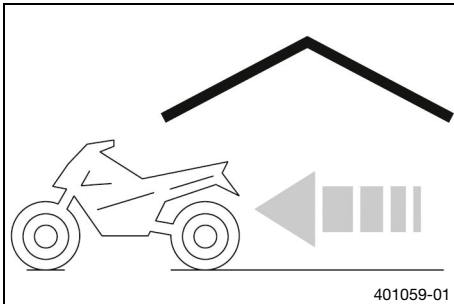
**20.2 Preparing for use after storage**

- Remove the motorcycle from the lift stand. (📖 p. 56)
- Install the 12-V battery. (🔌📖 p. 106)
- Perform checks and maintenance measures when preparing for use. (📖 p. 38)
- Make a test ride.









Faults	Possible cause	Action
The engine cannot be cranked (starter motor)	Operating error	– Carry out start procedure. (🔧 p. 38)
	12-V battery discharged	– Charge the 12-V battery. 🛠️ (🔧 p. 107) – Check the charging voltage. 🛠️ – Check the open-circuit current. 🛠️ – Check the stator winding of the alternator. 🛠️
	Main fuse blown	– Change the main fuse. (🔧 p. 109)
	Starter relay faulty	– Check the starter relay. 🛠️
	Starter motor faulty	– Check the starter motor. 🛠️
The engine turns but does not start	Operating error	– Carry out start procedure. (🔧 p. 38)
	Quick release coupling not joined	– Join quick release coupling.
	Idle speed is not set correctly	– Adjust the idle speed. 🛠️ (🔧 p. 126)
	Fuel supply interrupted	– Check the fuel tank breather.
	Spark plug sooty or wet	– Clean and dry the spark plug and spark plug connector, or change if necessary.
	Plug gap of spark plug too wide	– Adjust plug gap. Guideline Spark plug electrode gap 1.20 mm (0.0472 in)
	Faulty ignition	– Ignition coil - check the primary winding. 🛠️ – Check the spark plug connector. 🛠️ – Check the stator winding of the alternator. 🛠️
	Short-circuit cable in wiring harness frayed, stop button or emergency OFF switch faulty	– Check wiring harness (visual check). – Check the electrical system.
	The connector or ignition coil is loose or oxydized	– Clean the connector and treat with contact spray.
	Malfunction in the electronic fuel injection	– Read out the fault memory using the Husqvarna Motorcycles diagnostics tool. 🛠️
The engine has no idle speed	Spark plug defective	– Change the spark plug.
	Faulty ignition	– Ignition coil - check the primary winding. 🛠️ – Check the spark plug connector. 🛠️ – Check the stator winding of the alternator. 🛠️
	Idle speed is not set correctly	– Adjust the idle speed. 🛠️ (🔧 p. 126)
Engine does not speed up	Malfunction in the electronic fuel injection	– Read out the fault memory using the Husqvarna Motorcycles diagnostics tool. 🛠️









Faults	Possible cause	Action
Engine does not speed up	Faulty ignition	<ul style="list-style-type: none"> - Ignition coil - check the primary winding. 🛠️ - Check the spark plug connector. 🛠️ - Check the stator winding of the alternator. 🛠️
	Ambient pressure is incorrectly stored	- Program ambient air pressure. (📖 p. 127)
Engine has too little power	Air filter very dirty	- Clean the air filter and air filter box. 🛠️ (📖 p. 70)
	Fuel filter is very dirty	- Change the fuel filter. 🛠️
	Fuel screen is very dirty	- Change the fuel screen. 🛠️ (📖 p. 129)
	Malfunction in the electronic fuel injection	- Read out the fault memory using the Husqvarna Motorcycles diagnostics tool. 🛠️
	Fuel supply interrupted	- Check the fuel tank breather.
	Exhaust system leaks, deformed or too little glass fiber yarn filling in the main silencer	<ul style="list-style-type: none"> - Check exhaust system for damage. - Change the glass fiber yarn filling of the main silencer. 🛠️ (📖 p. 72)
	Faulty ignition	<ul style="list-style-type: none"> - Ignition coil - check the primary winding. 🛠️ - Check the spark plug connector. 🛠️ - Check the stator winding of the alternator. 🛠️
	Diaphragm or reed valve housing damaged	- Check the diaphragm and reed valve housing.
The engine dies during the trip	Lack of fuel	- Refuel. (📖 p. 42)
	The engine takes in false air	- Check that the intake flange is firmly seated.
	The connector or ignition coil is loose or oxydized	- Clean the connector and treat with contact spray.
	Ambient pressure is incorrectly stored	- Program ambient air pressure. (📖 p. 127)
Engine overheats	Too little coolant in cooling system	<ul style="list-style-type: none"> - Check the cooling system for leakage. - Check the coolant level. (📖 p. 119)
	Too little air stream	- Switch off engine when stationary.
	Radiator fins very dirty	- Clean the radiator fins.
	Foam formation in cooling system	<ul style="list-style-type: none"> - Drain the coolant. 🛠️ (📖 p. 119) - Refill with coolant. 🛠️ (📖 p. 120)
	Damaged cylinder head or cylinder head gasket	- Check the cylinder head and cylinder head gasket.
	Bent radiator hose	- Change the radiator hose. 🛠️
Thermostat defective	<ul style="list-style-type: none"> - Check the thermostat. 🛠️ <p>Guideline Opening temperature: 70 °C (158 °F)</p>	

Faults	Possible cause	Action
White smoke emission (steam in exhaust gas)	Damaged cylinder head or cylinder head gasket	– Check the cylinder head and cylinder head gasket.
Gear oil exits at the vent hose	Too much gear oil added	– Check the gear oil level. (📖 p. 135)
Water in the gear oil	Damaged radial shaft seal ring or water pump	– Check the radial shaft seal ring and the water pump.
Malfunction indicator lamp lights up or flashes	Malfunction in the electronic fuel injection	– Check wiring for damage and electrical plug-in connectors for corrosion and damage. – Read out the fault memory using the Husqvarna Motorcycles diagnostics tool. 🛠️
12-V battery discharged	The 12-V battery is not being charged by the alternator	– Check the charging voltage. 🛠️ – Check the stator winding of the alternator. 🛠️
	Unwanted electrical power consumer	– Check the open-circuit current. 🛠️
Values in combination instrument deleted (time, stop watch, lap times)	The combination instrument battery is empty	– Change combination instrument battery. (📖 p. 116)

i Info

The blink codes are only displayed by the derestricted version of the vehicle.

Blink code for malfunction indicator lamp	 45 Malfunction indicator lamp flashes 4x long, 5x short
Error level condition	TE 150i EU Lamda sensor heater – input signal too low
	TE 150i EU Lambda sensor heater - input signal too high
Blink code for malfunction indicator lamp	 14 Malfunction indicator lamp flashes 1x long, 4x short
Error level condition	Crankcase pressure sensor – difference too high between sensor and engine control unit
Blink code for malfunction indicator lamp	 09 Malfunction indicator lamp flashes 9x short
Error level condition	Crankcase pressure sensor - short circuit to ground
	Crankcase pressure sensor - open/short circuit to plus
	Ambient air pressure sensor – short circuit to ground
	Ambient air pressure sensor – open/short circuit to plus
Blink code for malfunction indicator lamp	 13 Malfunction indicator lamp flashes 1x long, 3x short
Error level condition	Intake air temperature sensor – input signal too low
	Intake air temperature sensor – input signal too high
Blink code for malfunction indicator lamp	 12 Malfunction indicator lamp flashes 1x long, 2x short
Error level condition	Coolant temperature sensor – input signal too low
	Coolant temperature sensor – input signal too high
Blink code for malfunction indicator lamp	 06 Malfunction indicator lamp flashes 6x short
Error level condition	Throttle valve position sensor circuit A - adaption failed
	Throttle valve position sensor circuit A – input signal too low
	Throttle valve position sensor circuit A – input signal too high
Blink code for malfunction indicator lamp	 17 Malfunction indicator lamp flashes 1x long, 7x short
Error level condition	TE 150i EU Lambda sensor – input signal too high
	TE 150i EU Lambda sensor - input signal too low

Blink code for malfunction indicator lamp	 41 Malfunction indicator lamp flashes 4x long, 1x short
Error level condition	Fuel pump - short circuit to ground/open circuit Fuel pump - open circuit/short circuit to plus
Blink code for malfunction indicator lamp	 33 Malfunction indicator lamp flashes 3x long, 3x short
Error level condition	Injection valve 0, cylinder 1 - input signal too low Injection valve 0, cylinder 1 - input signal too high
Blink code for malfunction indicator lamp	 34 Malfunction indicator lamp flashes 3x long, 4x short
Error level condition	Injection valve 1, cylinder 1 - input signal too low Injection valve 1, cylinder 1 - input signal too high
Blink code for malfunction indicator lamp	 37 Malfunction indicator lamp flashes 3x long, 7x short
Error level condition	Ignition coil - circuit fault
Blink code for malfunction indicator lamp	 02 Malfunction indicator lamp flashes 2x short
Error level condition	Crankshaft speed sensor - synchronization faulty Crankshaft speed sensor - signal implausible Crankshaft speed sensor - signal irregular Crankshaft speed sensor - no signal
Blink code for malfunction indicator lamp	 42 Malfunction indicator lamp flashes 4x long, 2x short
Error level condition	Oil pump - input signal too low Oil pump - input signal too high
Blink code for malfunction indicator lamp	 21 Malfunction indicator lamp flashes 2x long, 1x short
Error level condition	Battery voltage - input voltage too low Battery voltage - input voltage too high
Blink code for malfunction indicator lamp	 Malfunction indicator lamp lights up
Error level condition	Tilt sensor - input signal too low Tilt sensor - input signal too high

23.1 Engine

Design	1-cylinder 2-stroke engine, water-cooled, with reed intake and exhaust control
Displacement	144 cm ³ (8.79 cu in)
Stroke	54.5 mm (2.146 in)
Bore	58 mm (2.28 in)
Exhaust valve - Beginning of adjustment	6,300 rpm
Crankshaft bearing	1 grooved ball bearing/1 roller bearing
Conrod bearing	Needle bearing
Piston pin bearing	Needle bearing
Pistons	Cast aluminum
Piston rings	1 rectangular ring, 1 half keystone ring
Engine lubrication	Separate lubrication
X (upper edge of piston to upper edge of cylinder)	0 ... 0.10 mm (0 ... 0.0039 in)
Z (height of control flap)	37.5 mm (1.476 in)
Primary transmission	23:73
Clutch	Multidisc clutch in oil bath/hydraulically activated
Gearbox	6-gear transmission, claw shifted
Transmission ratio	
first-gear	12:33
second-gear	15:31
third-gear	17:28
fourth-gear	19:26
fifth-gear	21:25
sixth-gear	20:20
Alternator	12 V, 168 W
Ignition	Contactless controlled fully electronic ignition with digital ignition adjustment
Spark plug	NGK GR8DI-12
Spark plug electrode gap	1.20 mm (0.0472 in)
Cooling	Water cooling, permanent circulation of coolant by water pump
Starting aid	Electric starter system and kick starter system

23.2 Engine tightening torques

Screw, inner membrane sheets	EJOTDELTA PT[®] 35x25	1 Nm (0.7 lbf ft)	
Screw, membrane support plate	EJOTDELTA PT[®] 30x12	1 Nm (0.7 lbf ft)	
Screw, outer membrane sheets	EJOTDELTA PT[®] 30x6	1 Nm (0.7 lbf ft)	
Screw, clutch spring retainer	M5	6 Nm (4.4 lbf ft)	
Screw, crankshaft speed sensor	M5	6 Nm (4.4 lbf ft)	Loctite[®]243™
Screw, exhaust control cover	M5	5 Nm (3.7 lbf ft)	
Screw, locking lever	M5	6 Nm (4.4 lbf ft)	Loctite[®]243™

Screw, retaining bracket, rotary valve	M5	6 Nm (4.4 lbf ft) Loctite®2701™
Screw, stator	M5	6 Nm (4.4 lbf ft) Loctite®2701™
Screw, water pump wheel	M5	6 Nm (4.4 lbf ft) Loctite®243™
Bleeder screw, cylinder head	M6	8 Nm (5.9 lbf ft)
Drain plug, water pump cover	M6	10 Nm (7.4 lbf ft)
Nut, adjusting screw, power valve	M6	8 Nm (5.9 lbf ft)
Screw, alternator cover	M6	8 Nm (5.9 lbf ft)
Screw, bearing retainer	M6	10 Nm (7.4 lbf ft) Loctite®243™
Screw, clutch cover	M6x20	10 Nm (7.4 lbf ft)
Screw, clutch cover	M6x25	10 Nm (7.4 lbf ft)
Screw, clutch cover	M6x30	10 Nm (7.4 lbf ft)
Screw, clutch slave cylinder	M6	10 Nm (7.4 lbf ft)
Screw, control lever, exhaust control	M6	10 Nm (7.4 lbf ft) Loctite®243™
Screw, control lever, exhaust control	M6	10 Nm (7.4 lbf ft) Loctite®243™
Screw, engine case	M6	10 Nm (7.4 lbf ft)
Screw, exhaust flange	M6	10 Nm (7.4 lbf ft)
Screw, gear oil level monitoring	M6	8 Nm (5.9 lbf ft)
Screw, intake flange/reed valve housing	M6	6 Nm (4.4 lbf ft)
Screw, kick starter stop plate	M6	10 Nm (7.4 lbf ft) Loctite®243™
Screw, outer clutch cover	M6x20	8 Nm (5.9 lbf ft)
Screw, outer clutch cover	M6x50	8 Nm (5.9 lbf ft)
Screw, shift drum locating	M6	10 Nm (7.4 lbf ft) Loctite®243™
Screw, shift lever	M6	14 Nm (10.3 lbf ft) Loctite®243™
Screw, starter motor	M6	8 Nm (5.9 lbf ft)
Screw, starter motor guard	M6	8 Nm (5.9 lbf ft)
Screw, stop plate of exhaust control	M6	10 Nm (7.4 lbf ft) Loctite®243™
Screw, water pump cover	M6	10 Nm (7.4 lbf ft)
Screw, cylinder head	M7	18 Nm (13.3 lbf ft)
Nut, cylinder base	M8	23 Nm (17 lbf ft)
Screw, cylinder base	M8	10 Nm (7.4 lbf ft)
Screw, kick starter lever	M8	25 Nm (18.4 lbf ft) Loctite®2701™
Gear oil drain plug	M10x1	15 Nm (11.1 lbf ft)
Nut, rotor	M12x1	50 Nm (36.9 lbf ft)
Gear oil drain plug with magnet	M12x1.5	20 Nm (14.8 lbf ft)
Spark plug	M14x1.25	25 Nm (18.4 lbf ft)

Nut, primary gear wheel	M16LHx1.5	130 Nm (95.9 lbf ft) Loctite®243™
Nut, inner clutch hub	M18x1.5	100 Nm (73.8 lbf ft) Loctite®243™

23.3 Capacities

23.3.1 Gear oil

Gear oil	0.80 l (0.85 qt.)	Engine oil (15W/50) (📖 p. 155)
----------	-------------------	--------------------------------

23.3.2 Coolant

Coolant	1.2 l (1.3 qt.)	Coolant (📖 p. 155)
---------	-----------------	--------------------

23.3.3 Fuel

Total fuel tank capacity, approx.	8.5 l (2.25 US gal)	Super unleaded (ROZ 95) (📖 p. 156)
-----------------------------------	---------------------	---------------------------------------

Fuel reserve, approx.	1.5 l (1.6 qt.)	
-----------------------	-----------------	--

2-stroke oil tank content approx.	0.6 l (0.6 qt.)	Engine oil, 2-stroke (📖 p. 155)
-----------------------------------	-----------------	---------------------------------

23.4 Chassis

Frame	Central tube frame made of chrome molybdenum steel tubing	
Fork	WPXPLOR 5548	
Shock absorber	WPXACT 5750	
Suspension travel		
front	300 mm (11.81 in)	
rear	300 mm (11.81 in)	
Fork offset	22 mm (0.87 in)	
Brake system	Disc brakes, floating brake calipers	
Brake discs - diameter		
front	260 mm (10.24 in)	
rear	220 mm (8.66 in)	
Brake discs - wear limit		
front	2.5 mm (0.098 in)	
rear	3.5 mm (0.138 in)	
Street tire pressure (TE 150i EU)		
front	1.5 bar (22 psi)	
rear	1.8 bar (26 psi)	
Offroad tire pressure		
front	1.0 bar (15 psi)	
rear	1.0 bar (15 psi)	
Secondary ratio (TE 150i EU)	13:48 (13:50)	
Secondary ratio (TE 150i US)	13:50	
Chain	5/8 x 1/4"	

Rear sprockets available	48, 50, 52
Steering head angle	63.5°
Wheelbase	1,495 ± 10 mm (58.86 ± 0.39 in)
Seat height unloaded	950 mm (37.4 in)
Ground clearance unloaded	360 mm (14.17 in)
Weight without fuel approx.	99.6 kg (219.6 lb.)
Maximum permissible front axle load	145 kg (320 lb.)
Maximum permissible rear axle load	190 kg (419 lb.)
Maximum permissible overall weight	335 kg (739 lb.)

23.5 Electrical system

12-V battery	HJTZ5S-FP-C	Lithium-ion battery Battery voltage: 12 V Nominal capacity: 2.0 Ah Maintenance-free
Combination instrument battery	CR 2032	Battery voltage: 3 V
Headlight	HS1/socket BX43t	12 V 35/35 W
Position light	W5W / socket W2.1x9.5d	12 V 5 W
Indicator lamps	W2.3W / socket W2x4.6d	12 V 2.3 W
Turn signal (TE 150i EU)	R10W/socket BA15s	12 V 10 W
Brake/tail light	LED	
License plate lamp (TE 150i EU)	LED	
Fuse	75011088005	5 A
Fuse	75011088010	10 A
Fuse	58011109120	20 A

23.6 Tires

Front tire	Rear tire
90/90 - 21 M/C 54R M+S TT Michelin ENDURO MEDIUM	140/80 - 18 M/C 70R M+S TT Michelin ENDURO MEDIUM
The tires specified represent one of the possible series production tires. Additional information is available in the Service section under: www.husqvarna-motorcycles.com	

23.7 Fork

Fork article number	0266C161V401000
Fork	WPXPLOR 5548
Compression damping	
Comfort	18 clicks
Standard	15 clicks
Sport	12 clicks
Rebound damping	

Comfort	18 clicks	
Standard	15 clicks	
Sport	12 clicks	
Spring preload – preload adjuster		
Comfort	+0	
Standard	+0	
Sport	+3	
Spring length with preload spacer(s)	474 mm (18.66 in)	
Spring rate		
Weight of rider: 65 ... 75 kg (143 ... 165 lb.)	3.8 N/mm (21.7 lb/in)	
Weight of rider: 75 ... 85 kg (165 ... 187 lb.)	4.0 N/mm (22.8 lb/in)	
Weight of rider: 85 ... 95 kg (187 ... 209 lb.)	4.2 N/mm (24 lb/in)	
Fork length	928 mm (36.54 in)	
Fork oil per fork leg	636 ± 10 ml (21.5 ± 0.34 fl. oz.)	Fork oil (SAE 4) (48601166S1) (📖 p. 156)

23.8 Shock absorber

Shock absorber article number	0266C461V408000	
Shock absorber	WPXACT 5750	
Lowspeed compression damping		
Comfort	17 clicks	
Standard	15 clicks	
Sport	13 clicks	
Highspeed compression damping		
Comfort	2.5 turns	
Standard	2 turns	
Sport	1.5 turns	
Rebound damping		
Comfort	17 clicks	
Standard	15 clicks	
Sport	13 clicks	
Spring preload	10 mm (0.39 in)	
Spring rate		
Weight of rider: 65 ... 75 kg (143 ... 165 lb.)	36 N/mm (206 lb/in)	
Weight of rider: 75 ... 85 kg (165 ... 187 lb.)	39 N/mm (223 lb/in)	
Weight of rider: 85 ... 95 kg (187 ... 209 lb.)	42 N/mm (240 lb/in)	
Spring length		
Weight of rider: 65 ... 75 kg (143 ... 165 lb.)	255 mm (10.04 in)	
Weight of rider: 75 ... 85 kg (165 ... 187 lb.)	260 mm (10.24 in)	
Weight of rider: 85 ... 95 kg (187 ... 209 lb.)	260 mm (10.24 in)	
Gas pressure	10 bar (145 psi)	
Static sag	37 mm (1.46 in)	
Riding sag	110 mm (4.33 in)	
Fitted length	477 mm (18.78 in)	

Shock absorber fluid (🔧 p. 156)	SAE 2.5
---------------------------------	---------

23.9 Chassis tightening torques

Remaining screws, chassis	EJOT PT ® K60x25-Z	1 Nm (0.7 lbf ft)	
Screw, air filter box	EJOT PT ® K70x25	5 Nm (3.7 lbf ft)	
Screw, fuel pump	EJOT PT ®	2.5 Nm (1.84 lbf ft)	
Screw, intake air temperature sensor	EJOT PT ® K50x18	0.7 Nm (0.52 lbf ft)	
Screw, oil fill level sensor	G 3/4 "	7 Nm (5.2 lbf ft)	
Screw, pressure regulator	EJOT PT ® K60x25-Z	2.3 Nm (1.7 lbf ft)	
Screw, radiator hoses clip		2.4 Nm (1.77 lbf ft)	
Nut, throttle cable on throttle valve body	M4	3 Nm (2.2 lbf ft)	
Screw, emergency OFF switch (TE 150i EU)	M4	0.4 Nm (0.3 lbf ft)	
Screw, fixed grip	M4	5 Nm (3.7 lbf ft)	Loctite ®243™
Screw, stop button (TE 150i US)	M4	0.4 Nm (0.3 lbf ft)	
Screw, throttle valve body cover	M4	2.6 Nm (1.92 lbf ft)	
Screw, throttle valve body hose clamp	M4	2.8 Nm (2.07 lbf ft)	
Spoke nipple, front wheel	M4.5	6 Nm (4.4 lbf ft)	
Spoke nipple, rear wheel	M4.5	6 Nm (4.4 lbf ft)	
Remaining nuts, chassis	M5	5 Nm (3.7 lbf ft)	
Remaining screws, chassis	M5	5 Nm (3.7 lbf ft)	
Screw, battery terminal	M5	2.5 Nm (1.84 lbf ft)	
Screw, brake line guide for link fork	M5	5 Nm (3.7 lbf ft)	
Screw, frame protector	M5	3 Nm (2.2 lbf ft)	
Screw, shock absorber adjusting ring	M5	5 Nm (3.7 lbf ft)	
Nut, starter motor	M6	4 Nm (3 lbf ft)	
Remaining nuts, chassis	M6	10 Nm (7.4 lbf ft)	
Remaining screws, chassis	M6	10 Nm (7.4 lbf ft)	
Screw, absorbing element on frame	M6	6 Nm (4.4 lbf ft)	
Screw, absorbing element on manifold	M6	6 Nm (4.4 lbf ft)	
Screw, ball joint of push rod on foot brake cylinder	M6	10 Nm (7.4 lbf ft)	Loctite ®243™
Screw, battery support bracket	M6	6 Nm (4.4 lbf ft)	
Screw, brake lever	M6	5 Nm (3.7 lbf ft)	
Screw, cable on starter relay	M6	6 Nm (4.4 lbf ft)	
Screw, chain guide on link fork at the rear	M6x19	10 Nm (7.4 lbf ft)	Loctite ®243™
Screw, chain sliding guard	M6	10 Nm (7.4 lbf ft)	Loctite ®243™

Screw, clutch lever	M6	5 Nm (3.7 lbf ft)
Screw, front brake disc	M6	14 Nm (10.3 lbf ft) Loctite®243™
Screw, oil pump	M6	6 Nm (4.4 lbf ft)
Screw, oil pump holder on oil tank	M6	6 Nm (4.4 lbf ft)
Screw, rear brake disc	M6	14 Nm (10.3 lbf ft) Loctite®243™
Screw, seat fixing	M6	10 Nm (7.4 lbf ft)
Screw, throttle grip	M6	5 Nm (3.7 lbf ft)
Fuel connection on fuel pump	M8	15 Nm (11.1 lbf ft)
Nut, foot brake lever stop	M8	20 Nm (14.8 lbf ft)
Nut, rear sprocket screw	M8	35 Nm (25.8 lbf ft) Loctite®2701™
Nut, rim lock	M8	12 Nm (8.9 lbf ft)
Remaining nuts, chassis	M8	25 Nm (18.4 lbf ft)
Remaining screws, chassis	M8	25 Nm (18.4 lbf ft)
Screw, bottom triple clamp	M8	15 Nm (11.1 lbf ft)
Screw, chain sliding piece	M8	15 Nm (11.1 lbf ft)
Screw, engine brace	M8x15	25 Nm (18.4 lbf ft) Loctite®2701™
Screw, engine sprocket cover	M8	15 Nm (11.1 lbf ft)
Screw, fork stub	M8	15 Nm (11.1 lbf ft)
Screw, front brake caliper	M8	25 Nm (18.4 lbf ft) Loctite®243™
Screw, handlebar clamp	M8	20 Nm (14.8 lbf ft)
Screw, manifold	M8	15 Nm (11.1 lbf ft)
Screw, side stand attachment	M8	33 Nm (24.3 lbf ft) Loctite®2701™
Screw, subframe	M8	30 Nm (22.1 lbf ft) Loctite®2701™
Screw, top steering stem	M8	17 Nm (12.5 lbf ft) Loctite®243™
Screw, top triple clamp	M8	17 Nm (12.5 lbf ft)
Screw, wheel speed sensor on axle clamp	M8	4.5 Nm (3.32 lbf ft)
Nut, pull switch (TE 150i US)	M8x1	0.8 Nm (0.59 lbf ft)
Engine bracket screw	M10	60 Nm (44.3 lbf ft)
Remaining nuts, chassis	M10	45 Nm (33.2 lbf ft)
Remaining screws, chassis	M10	45 Nm (33.2 lbf ft)
Screw, bottom shock absorber	M10	60 Nm (44.3 lbf ft) Loctite®2701™
Screw, handlebar support	M10	40 Nm (29.5 lbf ft) Loctite®243™
Screw, top shock absorber	M10	60 Nm (44.3 lbf ft) Loctite®2701™
Nut, fuel pump fixation	M12	15 Nm (11.1 lbf ft)
Nut, angle lever to link fork	M14x1.5	60 Nm (44.3 lbf ft)
Nut, linkage lever on angle lever	M14x1.5	60 Nm (44.3 lbf ft)

23 TECHNICAL DATA

Nut, swingarm pivot	M16x1.5	100 Nm (73.8 lbf ft)
Nut, rear wheel spindle	M20x1.5	80 Nm (59 lbf ft)
Screw, front wheel spindle	M20x1.5	35 Nm (25.8 lbf ft)
Screw, top steering head	M20x1.5	12 Nm (8.9 lbf ft)
Screw-in fitting, cooling system	M24x1.5	18 Nm (13.3 lbf ft)

Loctite®243™

Brake fluid DOT 4 / DOT 5.1**Standard/classification**

- DOT

Guideline

- Use only brake fluid that complies with the specified standard (see specifications on the container) and that exhibits the corresponding properties.

Recommended supplier**Castrol**

- REACT PERFORMANCE DOT 4

MOTOREX®

- Brake Fluid DOT 5.1

Coolant**Guideline**

- Only use high-grade, silicate-free coolant with corrosion inhibitor additive for aluminum motors. Low grade and unsuitable antifreeze causes corrosion, deposits and frothing.
- Do not use pure water as only coolant is able to meet the requirements needed in terms of corrosion protection and lubrication properties.
- Only use coolant that complies with the requirements stated (see specifications on the container) and that has the relevant properties.

Antifreeze protection to at least	-25 °C (-13 °F)
-----------------------------------	-----------------

The mixture ratio must be adjusted to the necessary antifreeze protection. Use distilled water if the coolant needs to be diluted.

The use of premixed coolant is recommended.

Observe the coolant manufacturer specifications for antifreeze protection, dilution and miscibility (compatibility) with other coolants.

Recommended supplier**MOTOREX®**

- COOLANT M3.0

Engine oil (15W/50)**Standard/classification**

- JASO T903 MA2 (📖 p. 159)
- SAE (📖 p. 159) (15W/50)

Guideline

- Use only engine oils that comply with the specified standards (see specifications on the container) and that possess the corresponding properties.

Recommended supplier**MOTOREX®**

- Top Speed 4T

Engine oil, 2-stroke**Standard/classification**

- JASO FD (📖 p. 159)

Guideline

- Only use high-grade 2-stroke engine oil from a reputable brand.

fully synthetic

Recommended supplier

MOTOREX®

- Cross Power 2T

Fork oil (SAE 4) (48601166S1)

Standard/classification

- SAE (📖 p. 159) (SAE 4)

Guideline

- Use only oils that comply with the specified standards (see specifications on the container) and that exhibit the corresponding properties.

Shock absorber fluid (SAE 2.5) (50180751S1)

Standard/classification

- SAE (📖 p. 159) (SAE 2.5)

Guideline

- Use only oils that comply with the specified standards (see specifications on the container) and that exhibit the corresponding properties.

Super unleaded (ROZ 95)

Standard/classification

- DIN EN 228 (ROZ 95)

Guideline

- Only use super unleaded fuel that matches or is equivalent to the specified standard.
- Fuel with an ethanol content of up to 10% (E10 fuel) is safe to use.



Info

Do **not** use fuel containing methanol (e.g., M15, M85, M100) or more than 10% ethanol (e.g., E15, E25, E85, E100).

Air filter cleaner

Recommended supplier

MOTOREX®

- Racing Bio Dirt Remover

Chain cleaner

Recommended supplier

MOTOREX®

- Chain Clean

High viscosity grease

Recommended supplier

SKF®

- LGHB 2

Long-life grease

Recommended supplier

MOTOREX®

- Bike Grease 2000

Motorcycle cleaner

Recommended supplier

MOTOREX®

- Moto Clean

Off-road chain spray

Recommended supplier

MOTOREX®

- Chainlube Offroad

Oil for foam air filter

Recommended supplier

MOTOREX®

- Racing Bio Liquid Power

Preserving materials for paints, metal and rubber

Recommended supplier

MOTOREX®

- Moto Protect

Silicone spray

Recommended supplier

MOTOREX®

- Silicone Spray

Special cleaner for glossy and matte paint finishes, metal and plastic surfaces

Recommended supplier

MOTOREX®

- Quick Cleaner

Universal oil spray

Recommended supplier

MOTOREX®

- Joker 440 Synthetic

JASO T903 MA2

Different technical development directions required a separate specification for motorcycles – the **JASO T903 MA2** standard.

Earlier, engine oils from the automobile industry were used for motorcycles because there was no separate motorcycle specification.

Whereas long service intervals are demanded for automobile engines, the focus for motorcycle engines is on high performance at high engine speeds.

In most motorcycle engines, the transmission and clutch are lubricated with the same oil.

The **JASO T903 MA2** standard meets these special requirements.

SAE

The SAE viscosity classes were defined by the Society of Automotive Engineers and are used for classifying oils according to their viscosity. The viscosity describes only one property of oil and says nothing about quality.

JASO FD

JASO FD is a classification for a 2-stroke engine oil that was specifically developed for the extreme demands of racing. Thanks to first-rate synthetic esters and specially designed additives, superb combustion is achieved even under extreme operating conditions.

27 INDEX OF SPECIAL TERMS

-	Injection in the transfer ducts	Electronic fuel injection in which two injection valves in the transfer ducts of the cylinders are used
OBD	On-board diagnosis	Vehicle system, which monitors the specified parameters of the vehicle electronics

Art. no.	Article number
ca.	circa
cf.	compare
e.g.	for example
etc.	et cetera
i.a.	inter alia
no.	number
poss.	possibly



29.1 Red symbols

Red symbols indicate an error condition that requires immediate intervention.

	<p>The oil level warning lamp lights up red – Oil level has reached the MIN marking. Ride for no more than until the remaining fuel in the tank is depleted and at the next opportunity refuel with 2-stroke oil.</p>
---	--



29.2 Yellow and orange symbols

Yellow and orange symbols indicate an error condition that requires prompt intervention. Active driving aids are also represented by yellow or orange symbols.

	<p>Malfunction indicator lamp lights up/flashes yellow – The OBD has detected a malfunction in the vehicle electronics. Come safely to a halt, and contact an authorized Husqvarna Motorcycles workshop.</p>
	<p>The fuel level warning lamp lights up yellow – The fuel level has reached the reserve mark.</p>

29.3 Green and blue symbols

Green and blue symbols reflect information.

	<p>Turn signal indicator lamp flashes green – The turn signal is switched on.</p>
	<p>The high beam indicator lamp lights up blue – The high beam is switched on.</p>

1

12-V battery	
charging	107
installing	106
removing	104
starting power	33

2

2-stroke oil level	
checking	130
2-stroke oil tank cap	
closing	22
opening	22

A

Air filter	
cleaning	70
installing	71
removing	70
Air filter box	
cleaning	70
Air filter box cover	
installing	69
removing	69
Ambient pressure	
programming	127
Antifreeze	
checking	118
Auxiliary substances	11

B

Basic chassis setting	
rider's weight, checking with	47
Blink code	145-146
Brake discs	
checking	87
Brake fluid	
front brake, adding	88
of rear brake, adding	94
Brake fluid level	
front brake, checking	88
rear brake, checking	94
Brake linings	
front brake, checking	89
of the front brake, changing	90
of the rear brake, changing	96
rear brake, checking	95

C

Capacity	
Coolant	149
fuel	43, 149
Gear oil	136, 149
Chain	
checking	79
cleaning	77
Chain guide	
checking	79
Chain tension	
adjusting	78
checking	78
Characteristic map of the throttle response	
adjusting	125
Cleaning, care	138-139
Clutch	
fluid level, checking/correcting	84
fluid, changing	85
Clutch lever	17
basic position, adjusting	83
Cold start button	22
Combination instrument	
adjusting	26
combination instrument battery, changing	116
message	26
overview	26
service display, setting	28
setting the clock	28
setting the kilometers or miles	27
Compression damping	
fork, adjusting	53
Coolant	
changing	122
draining	119
refilling	120
Coolant level	
checking	118-119
Cooling system	118
Customer service	12

D

Diagnostics connector	117
Difficult operating conditions	33
dry sand	33
low temperature	37
muddy surfaces	36
snow	37
wet sand	35

wet surfaces	36	Fuel tank filler cap	
Difficult riding conditions		closing	21
high temperatures	36	opening	21
slow speed	36	Fuel, oils, etc.	11
E		Fuse	
Emergency OFF switch	19	main fuse, changing	109
Engine		of individual electrical power consumers, changing	110
running in	32	G	
Engine guard		Gear oil	
installing	86	adding	136
removing	86	changing	135
Engine number	15	Gear oil level	
Engine sprocket		checking	135
checking	79	H	
Environment	10	Hand brake lever	17
F		basic position, adjusting	87
Figures	11	Handlebar position	54
Foot brake lever		adjusting	55
basic position, adjusting	93	Headlight	
free travel, checking	92	range, adjusting	116
Foot brake pedal	24	Headlight bulb	
Fork		changing	114
article number	16	Headlight mask with headlight	
basic setting, checking	52	installing	112
Fork legs		removing	112
bleeding	56	Headlight setting	
dust boots, cleaning	57	checking	115
installing	58	High-speed compression damping	
removing	57	shock absorber, adjusting	48
spring preload, adjusting	54	Horn button	18
Fork protector		I	
installing	59	Idle speed	
removing	59	adjusting	126
Frame		Idle speed adjusting screw	23
checking	82	Implied warranty	11
Front fender		Intended use	7
installing	64	K	
removing	63	Key number	15
Front wheel		Kick starter lever	24
installing	99	L	
removing	98	Light switch	18
Fuel screen		Link fork	
changing	129	checking	82
Fuel tank		Lower triple clamp	
installing	75	installing	60
removing	74		

removing	59	Riding sag	
Low-speed compression damping		adjusting	52
shock absorber, adjusting	47	Right side cover	
M		installing	73
Main fuse		removing	73
changing	109	Rubber grip	
Main silencer		checking	83
glass fiber yarn filling, changing	72	S	
installing	72	Safe operation	8
removing	71	Seat	
Manufacturer warranty	11	mounting	68
Map switch	20	removing	68
Misuse	7	Service	11
Motorcycle		Service schedule	44-46
cleaning	138	Shift lever	23
lift stand, raising with	56	basic position, adjusting	128
lift stand, removing from	56	basic position, checking	127
O		Shock absorber	
Oil pump		article number	16
priming	130	compression damping, general	47
Oil screen		installing	66
cleaning	132	removing	65
Overview of indicator lamps	20	riding sag, checking	50
Owner's Manual	10	spring preload, adjusting	51
P		static sag, checking	50
Play in throttle cable		Side stand	24
adjusting	124	Spare parts	11
checking	124	Spoke tension	
Preparing for use		checking	103
advice on preparing for first use	31	Start button	19
after storage	141	Starting	38
checks and maintenance measures when		Starting power of lithium-ion batteries at low	
preparing for use	38	temperatures	33
Protective clothing	9	Steering	
R		locking	25
Rear sprocket		unlocking	25
checking	79	Steering head bearing	
Rear wheel		lubricating	63
installing	100	Steering head bearing play	
removing	99	checking	62
Rebound damping		setting	63
fork, adjusting	53	Stop button	17-18
shock absorber, adjusting	49	Storage	140
Refueling		T	
2-stroke oil	43	Technical accessories	11
fuel	42	Technical data	
		capacities	149
		chassis	149

chassis tightening torques	152
electrical system	150
engine	147
engine tightening torques	147
fork	150
shock absorber	151
tires	150
Throttle cable routing	
checking	82
Throttle grip	17
Tire condition	
checking	102
Tire pressure	
checking	102
Transporting	41
Troubleshooting	142-144
Turn signal bulb	
changing	114
Turn signal switch	19
Type label	15
U	
Use definition	7
V	
Vehicle identification number	15
View of vehicle	
front left	13
rear right	14
W	
Winter operation	
checks and maintenance steps	139
Work rules	9



3402537en

11/2021



Husqvarna Motorcycles GmbH
Stallhofnerstraße 3 | 5230 Mattighofen | Austria
www.husqvarna-motorcycles.com



Photo: Mitterbauer/KISKA,
Husqvarna Motorcycles GmbH