



# LAGUNA

## 151-MFlux5

### MFlux 5 Mobile Air Filter

Manual



Producer

**Laguna Tools Inc.**

744 Refuge Way, Suite 200 Grand Prairie, Texas 75050

USA

Phone: +1 800-234-1976

Website: [www.lagunatools.com](http://www.lagunatools.com)

Distributor

**IGM nástroje a stroje s.r.o.**

Ke Kopanině 560, 252 67, Tuchoměřice

Czech Republic, EU

Phone: +420 220 950 910

E-mail: [sales@igmtools.com](mailto:sales@igmtools.com)

Website: [www.igmtools.com](http://www.igmtools.com)

2024-11-18

151-MFlux5 LAGUNA Mobile Air Filter Manual EN v1.02.00 A4ob  
VZOR\_Návod k obsluze STROJ EN v1.00.00



PDF ONLINE  
[www.igmtools.info](http://www.igmtools.info)



## **EN – English Manual**

Dear customer,

thank you for the confidence you have placed in us with the purchase of your new Laguna machine from IGM. This manual was prepared for the owner and operator of **IGM LAGUNA MFlux 5 Mobile Air Filter** to promote safety during setup, operation and maintenance. Please read carefully and understand the information contained in this manual and accompanying documents. To obtain maximum service life and performance, use the machine according to these instructions and safety guidelines. Observe work safety.

We wish you a lot of work satisfaction and joy when working with the IGM LAGUNA MFlux 5 Mobile Air Filter.

### **Contents**

1. EC DECLARATION OF CONFORMITY
- 1.1 Warranty
2. Product Specifications
3. Safety
  - 3.1 Intended Use
  - 3.2 General Safety Instructions
  - 3.3 Symbols
  - 3.4 Additional Instructions for Air Filters
  - 3.5 Power Supply
  - 3.6 Environment
4. Machine Description
  - 4.1 Package Contents
  - 4.2 Parts Description
5. Setup
  - 5.1 Unpacking
  - 5.2 Assembly
  - 5.3 Operation
6. Maintenance and Inspection
  - 6.1 Replacing the HEPA Filter
7. Accessories
8. Troubleshooting
9. Wiring
10. Parts List

**EC DECLARATION OF CONFORMITY**

According to the following EC Directives

- Machinery Directive: 2006/42/EC

**The applicant: LAGUNA TOOLS, INC./ 744 Refuge Way, Suite 200, Grand Prairie, Texas 75050 USA****Manufacturer: SAN FORD MACHINERY CO., LTD./ No.169, Chung shan Rd., FengYuan Dist., Taichung City 420, Taiwan (R.O.C.), Taiwan, manufacturer, declares that the machine described hereafter:****AIR CLEANER MODEL:*****MFLUX5***

Provided that it is used and maintained in accordance with the generally accepted codes of good practice and the recommendations of the instructions manual, meets the essential safety and health requirements of the Machinery Directive.

The person who compile technical file established within the EU:

Name: IGM nastroje a stroje s.r.o.

Address: Ke Kopanine 560, Tuchomerice, CZ-252 67

Tel.: +420 220 950 910

Email: [sales@igmtools.com](mailto:sales@igmtools.com)

**The TCF (No. SF-2024003-A1) is archived by CEPROM S.A. located in Str. Fântânele f.n., 440240 Satu Mare, judetul Satu Mare, Romania.**

For the most specific risks of this machine, safety and compliance with the essential requirements of the Directive has been based on elements of:

- **EN ISO 12100:2010 / Safety of machinery - General principles for design - Risk assessment and risk reduction (ISO 12100:2010)**
- **EN 60204-1:2018 / Safety of machinery - Electrical equipment of machines- Part 1: General requirements- Industrial electrical device.**



Date: 11.11.2024

Authorized Signature:

Position: Chief Executive Officer

Place: Laguna Tools Inc.

744 Refuge Way, Suite 200, Grand Prairie, Texas 75050, USA

## 1.1 Warranty

IGM always strives to deliver a high-quality and efficient product. The warranty is governed by the valid terms and conditions of IGM.

## 2. Product Specifications

|                             |   |
|-----------------------------|---|
| Machine Dimensions (LxWxH): | 483 x 452 x 925 mm                              |
| Machine Weight:             | 45,1 kg   |
| Package Dimensions (LxWxH): | 960 x 490 x 480 mm                              |
| Package Weight:             | 47,5 kg   |
| Noise Level:                | 58-61 dB  |
| Motor:                      | 750 W   |
| Power:                      | 230 V / 50 Hz / 1 Phase                         |
| Maximum Airflow:            | 530 m3/hour (313 CFM)                           |
| Fan Diameter:               | 230 mm (9")                                     |
| Inlet Diameter:             | 1x 150 mm and 4x 100 mm (only with accessory)   |
| Switch:                     | High-frequency remote control switch            |
| Filter:                     | 2x HEPA – 99,99 % of particles over 0,3 microns |
| Filtered Area:              | 5,29 m <sup>2</sup>                             |
| Filter Dimensions:          | 330 x 330 x 100 mm                              |

## 3. Safety

Proper use includes compliance with the instructions given in this manual and general regulations applicable in your country. The operator is liable for any use in violation of the intended use.

### 3.1 Intended Use









The machine is designed to filter non-explosive atmospheres only. Do not use to collect saw dust from wood and woodworking machines. Collection of any other material is prohibited.

### 3.2 General Safety Instructions

**Warning!** Read all instructions and safety guidelines. Failure to follow safety instructions may result in damage to the machine and serious injury to the operator. Keep the manual for future reference.

- The machine may be dangerous if not used properly.
- The machine may be operated only by a person familiar with the contents of this manual and machine operation.
- Keep children and pets away from packaging materials supplied with this machine.
- Place the machine on a stable and well-lit surface. There must be sufficient space around the machine for safe operation.
- Check the technical condition of the machine before operation. The machine may be used only in a perfect technical condition. If you notice any defects, do not start the machine and have it repaired by a qualified person.
- Replace damaged parts immediately. Use only original spare parts.
- All safety covers must be mounted before operation. Replace damaged covers immediately.
- The machine may be used, assembled, and maintained only by persons familiar with its operation and aware of potential danger. No changes to the machine may be made!
- Carry out maintenance regularly.
- Keep the machine and the surrounding area clean and well-lit. Remove all tools from the machine and surroundings before starting the machine.
- Carry out assembly, repairs and maintenance only when the machine is disconnected from the power supply.
- Prevent unintentional start of the machine. Before connecting the machine to the power supply, make sure the switch is in the OFF position.
- Make sure the circuit requirements specified in this manual are met.
- Take care of your safety when operating the machine. Long hair, loose clothing and jewellery may cause injury. Wear suitable work clothing, footwear, head, eye, ear and respiratory protection.
- Do not use gloves when operating the machine.
- Do not operate the machine if you are tired, ill or under the influence of drugs or alcohol.
- Watch your hands and fingers. Always use both hands when working.
- Do not lean over the machine. Always maintain balance and stand on a firm and stable surface when working.
- Keep children and other persons from moving freely around the workplace. Keep the machine out of reach of children and unqualified persons. Do not allow anyone unfamiliar with the machine and this manual to operate the machine.
- Never leave a running machine unattended. After you finish your work, turn off the machine and disconnect it from the power supply.
- Do not leave the machine in a damp environment and do not expose it to rain.
- Do not overload the machine.
- Do not operate the machine near flammable liquids or gases.
- Keep the motor fan clear.

### 3.3 Symbols

|  |  |
|--|--|
|   | Read the manual and all instructions carefully before use. |
|   | Wear eye protection.                                       |
|   | Wear respiratory protection.                               |
|   | Disconnect the machine from the power supply.              |
|   | Scan the QR code to find the manual.                       |
|   | CE mark: The product is in compliance with EEA directives. |
|   | Do not dispose of the appliance in the municipal waste.    |
|  | Recycle package materials.                                 |

### 3.4 Additional Instructions for Air Filters

**Caution!** Dust containing harmful chemicals such as lead from lead-based paints or arsenic and chromium from chemically treated lumber can be produced during operation. Work in a well-ventilated area and wear approved protective equipment. Observe safety regulations applicable in your country.

- Wear eye and respiratory protection when operating and maintaining the machine.
- Dispose of dirty filters following local regulations applicable in your country.
- Make sure the casters are locked before turning the machine on.
- Do not place your hands or tools near the air intake.
- Make sure that the intake and exhaust areas are clear and free from obstruction before turning the machine on.
- Use the machine only with the filters installed.
- Collect intended material only. If you accidentally collect material other than the approved, stop working and turn the machine off immediately. Check the condition of the machine.

### 3.5 Power Supply

**Warning!** Any modification to the electrical installation may be carried out only by a qualified electrician in accordance with all applicable regulations.

**Warning!** Do not connect the machine to the power supply until it is ready for operation.



#### Circuit Requirements

**Warning!** These requirements apply to a dedicated circuit where only one machine runs at a time. Consult a qualified electrician before connecting the machine to a shared circuit. Make sure the circuit is properly sized for safe operation.

This machine is designed to operate on a grounded power supply. The power circuit includes all electrical appliances between the machine and the breaker box or fuse panel in the building. The power circuit used for this machine must be sized to safely handle a full load current for an extended time.

#### Grounding and Plug Requirements

**Caution!** Improper grounding and connection of the machine to the power supply may result in an electric shock, damage or fire.

This machine is equipped with a grounded power cord. Insert the plug only into a matching outlet that is properly installed and grounded in accordance with all local regulations. Do not modify the provided plug!

Do not use the machine if the power cord or plug is damaged. All repairs may be carried out only by a qualified electrician!

### 3.6 Environment

Do not dispose of the appliance in the municipal waste. Electronic appliances must be collected and handed in for proper recycling. Recycle package material and other accessories. Observe safety regulations applicable in your country.



## 4. Machine Description

Carefully observe the images below and familiarize yourself with the package contents and listed machine parts and features.

### 4.1 Package Contents

- 1) MFlux 5 Air filter
- 2) 4x Handle
- 3) Hardware
- 4) Remote control
- 5) EN manual

### 4.2 Parts Description

#### Control panel

A. On board circuit breaker

Pops out if the machine is overloaded. Allow the machine to cool down for a few minutes. Then press the reset button.

B. ON/OFF switch

Turns the collector on or off.

C. Control panel pair button / Filter timer reset button

Used to pair remote control with the machine and to reset filter change indicator.

D. LED filter change indicator

Indicates the need to replace the HEPA filter with a new one.



## Remote control

The remote control requires a 12V battery type 27A.

- A. ON button
- B. OFF button
- C. CLEAN button (PFlux only)
- D. Remote control pair button



### Pairing remote control

1. Ensure the machine is ON before pairing the remote control.
2. Press the control panel pair button until you hear two beeps.
3. Press the remote-control pair button simultaneously with the control panel pair button until you hear three beeps. The remote control is now paired.

### Pairing more remote controls

You can pair up to 5 remotes to one machine. Each remote must be paired separately. If you pair a sixth remote to the machine, the first paired remote will be disconnected and replaced by the sixth remote. This also applies to the next remotes.

## 5. Setup

Approximate assembly and setup time: 15 minutes

### 5.1 Unpacking

When unpacking, separate the machine and all supplied parts from the packaging materials. Check that no parts have been damaged. If damage has occurred as a result of transport, contact your supplier immediately.

The machine is supplied in a single box. Two people should take the machine out of the box.

1. Cut along the tape line at the top of the box.
2. Remove all parts from the top of the polystyrene and set aside.
3. Remove the polystyrene packing material.
4. Carefully take the machine out of the box and set it on casters.
5. Check all parts according to package contents.

### 5.2 Assembly

Take the four handles and hex bolts. Attach two handles to both sides.



### 5.3 Operation

Ensure sufficient airflow. Check each box of the modular design for obstructions or foreign objects.

1. Secure all boxes with latches before turning the machine on.
2. Confirm that the power is supply is connected correctly and without damage.
3. Check the surroundings. Do not carry out any repairs or maintenance on the machine when in use!
4. To start, press the ON button on either the control panel or paired remote control.
5. To stop, press the OFF button on either the control panel or paired remote control.

### 6. Maintenance and Inspection

**Caution!** Disconnect the machine from the power supply before maintenance and inspection. Carry out maintenance regularly.

**Before each use**, check for loose or damaged parts and whether the cord is worn out or damaged. Do not use the machine until all defects have been fixed. **After each use**, clean dust and other waste from the machine and surrounding area. Wipe the machine using a dry cloth.

**Carry out the following tasks regularly:**

- Check for leaks.
- Clean the filters and their parts.

#### 6.1 Replacing the HEPA Filter

This machine is equipped with a 4000 hour LED filter change indicator. When the filter indicator light blinks twice then your filters need to be replaced.

Once you have replaced your filters, press the filter timer reset button 5 times to reset the timer.

If you also install the carbon filter on your machine, we recommend changing all filters at the same time. The carbon filter and the HEPA filter have the same service life of 4000 operating hours.

1. Open latches on both sides.



Locked



Unlocked

2. Each HEPA filter is secured with four fasteners. To remove the HEPA filter, first lift and remove the four fasteners.

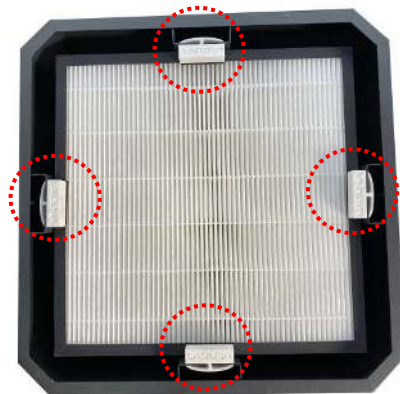

3. Remove the HEPA filter and replace with a one. Make sure to insert the filter following the arrow on the label.



4. When replaced, make sure to reinsert the four fasteners and lock the box in place with latches. Ensure that the boxes are lined up to avoid leaks. Don't forget to reset the timer.

### 7. Accessories

Recommended accessories are listed on the IGM website.

**Caution!** Installing unapproved accessories may cause damage to the machine and serious injury. Use only accessories recommended for this machine by IGM.

### 8. Troubleshooting

|   |   |
|---|---|
| <p><b>Machine does not start or a breaker trips.</b> Possible Cause:</p> <ol style="list-style-type: none"> <li>1) Power supply is turned OFF or faulty.</li> <li>2) Wall fuse/circuit breaker is blown/tripped.</li> <li>3) Faulty remote control.</li> <li>4) Incorrectly wired motor connection.</li> <li>5) On-board circuit breaker is tripped.</li> <li>6) Wiring is open/has high resistance.</li> <li>7) Faulty power switch.</li> <li>8) Motor is at fault.</li> </ol> | <p>Possible Solution:</p> <ol style="list-style-type: none"> <li>1) Ensure power supply is ON and has the correct voltage.</li> <li>2) Ensure adequate circuit size, reset breaker.</li> <li>3) Replace batteries; ensure unobstructed line of sight and signal range.</li> <li>4) Rewire or call certified service technician or electrician.</li> <li>5) Allow motor to cool, improve ventilation, press reset button.</li> <li>6) Check for broken wires or poor connections, repair as necessary.</li> <li>7) Replace switch.</li> <li>8) Test/repair/replace.</li> </ol> |
| <p><b>Excessive vibration or noise during operation.</b> Possible Cause:</p> <ol style="list-style-type: none"> <li>1) Loose component.</li> <li>2) Loose or broken motor mount.</li> <li>3) Motor fan hitting fan cover.</li> <li>4) Bad motor bearings.</li> </ol>  | <p>Possible Solution:</p> <ol style="list-style-type: none"> <li>1) Inspect and tighten all bolts/nuts.</li> <li>2) Tighten or replace as needed.</li> <li>3) Check fan and cover; replace as needed.</li> <li>4) Rotate shaft manually, check for grinding or loose shaft, replace bearings if needed.</li> </ol>  |
| <p><b>Loud or repetitive noise, excessive vibration coming from machine.</b> Possible Cause:</p> <ol style="list-style-type: none"> <li>1) Machine is on uneven surface.</li> <li>2) Damaged/Unbalanced fan.</li> <li>3) Loose connections.</li> <li>4) Fan is loose.</li> <li>5) Motor fan hitting fan cover.</li> </ol>   | <p>Possible Solution:</p> <ol style="list-style-type: none"> <li>1) Stabilize on a flat surface.</li> <li>2) Inspect fan for dents, bends, or other damage.</li> <li>3) Check and re-tighten all fasteners.</li> <li>4) Replace the motor and fan.</li> <li>5) Check fan and cover; replace as needed.</li> </ol>   |

9. Wiring

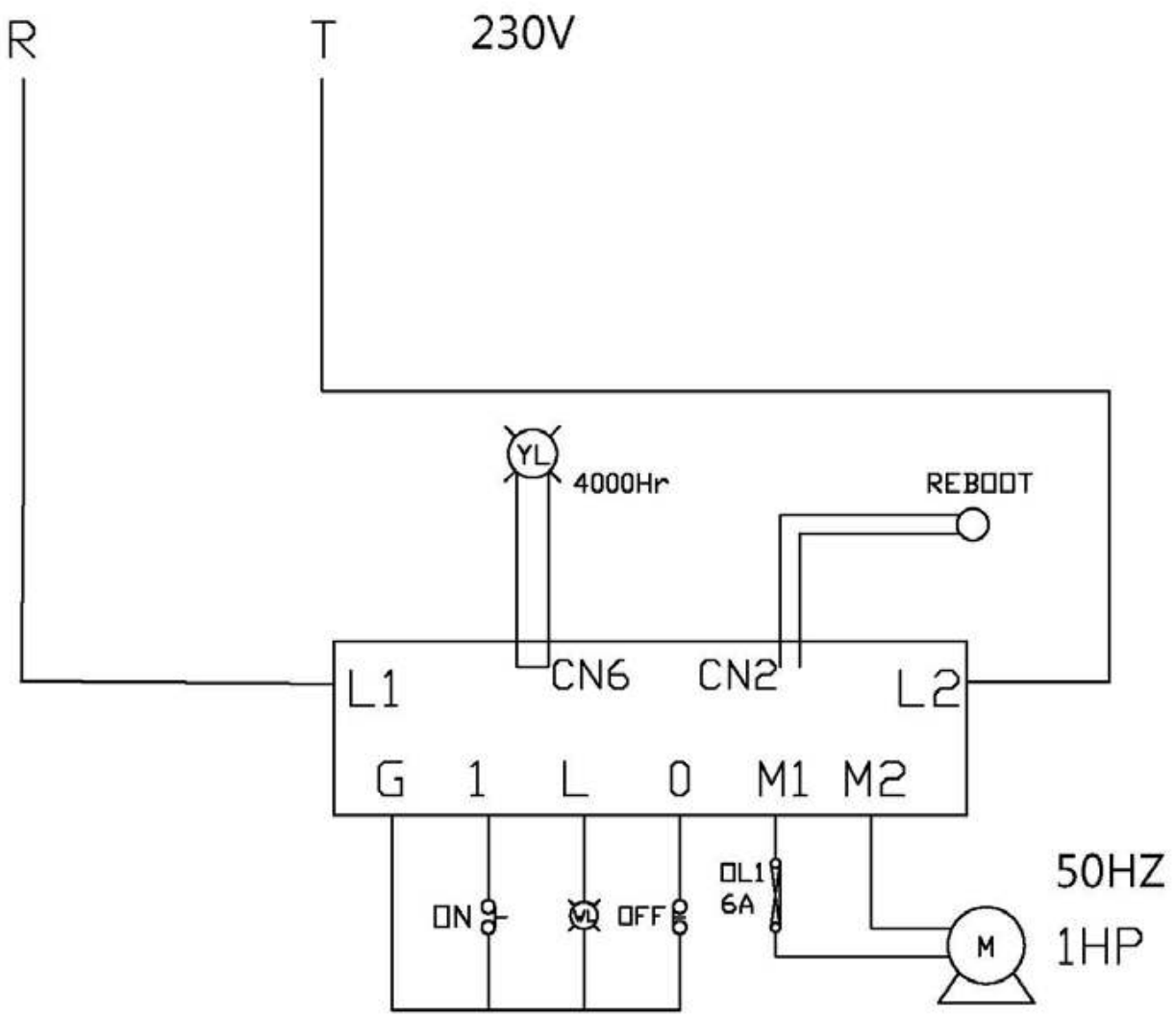

# 10. Parts List

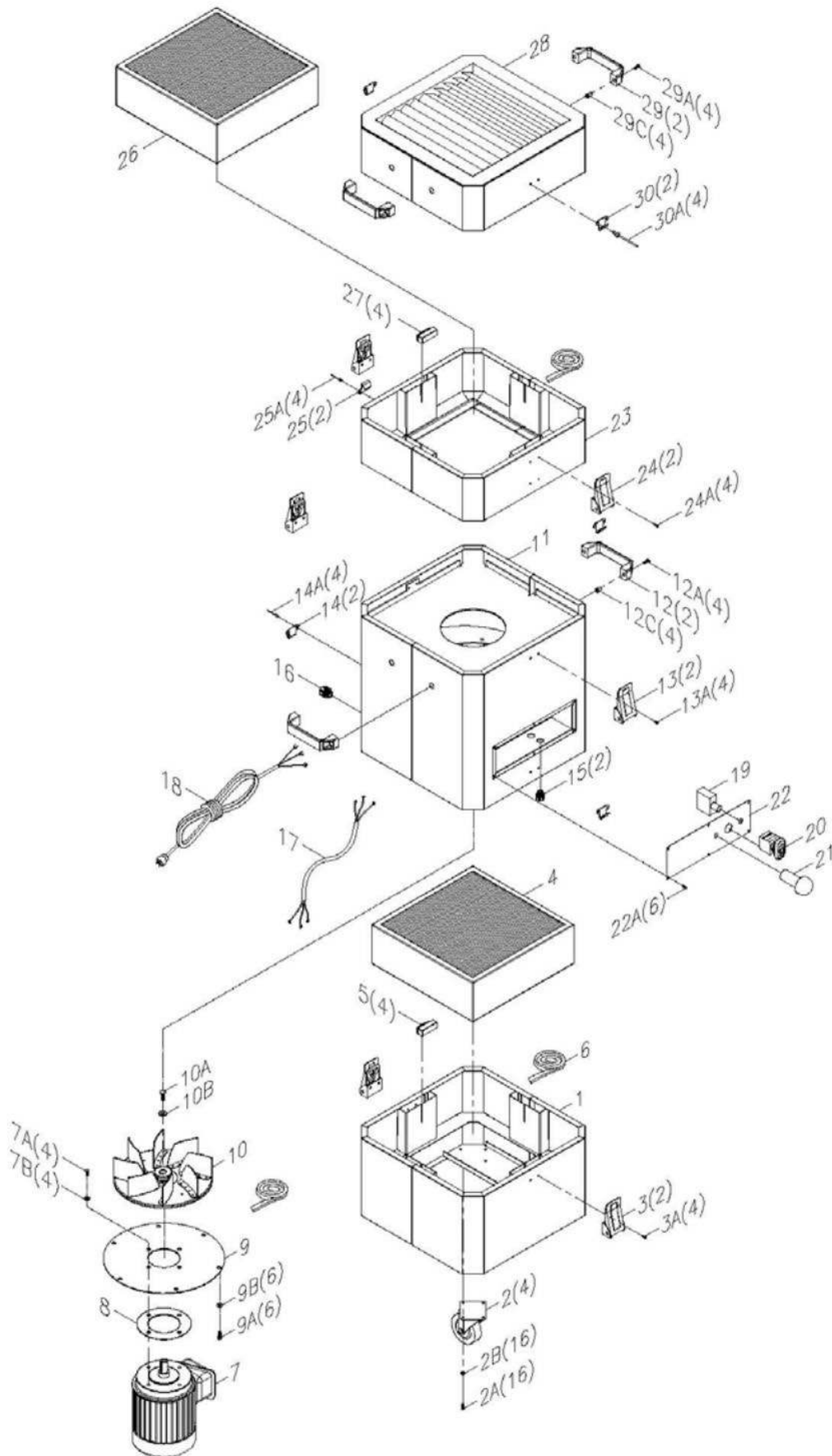

| Ref No | Part Name            | Description                | Q'TY |
|--------|----------------------|----------------------------|------|
| 1      | EXHAUSTFILTERBOX     |                            | 1    |
| 2      | 3"WHEEL              |                            | 4    |
| 2A     | HEX BOLT             | 1/4"*3/4"                  | 16   |
| 2B     | FLAT WASHER          | 1/4"                       | 16   |
| 3      | LATCH                | 85#                        | 2    |
| 3A     | ROUND PH HD SCREW    | 3/16"*3/8"                 | 4    |
| 4      | HEPA FILTER          | 330*330*100mm              | 1    |
| 5      | HEPAFILTER FASTENER  |                            | 4    |
| 6      | FOAM TAPE            | 3/15mm                     | 1    |
| 7      | MOTOR                | 1HP/230V/50HZ/SINGLE PHASE | 1    |
| 7A     | HEX BOLT             | 5/16"*3/4"                 | 4    |
| 7B     | FLAT WASHER          | 5/16"                      | 4    |
| 8      | MOTOR GASKET         |                            | 1    |
| 9      | MOTOR SUPPORT BASE   |                            | 1    |
| 9A     | HEX BOLT             | 1/4"*3/4"                  | 6    |
| 9B     | FLAT WASHER          | 1/4"                       | 6    |
| 10     | FAN                  | 9"                         | 1    |
| 10A    | HEX BOLT             | 5/16"*3/4"                 | 1    |
| 10B    | IMPELLER WASHER      | 5/16"                      | 1    |
| 11     | FAN HOUSING          |                            | 1    |
| 12     | HANDLE               |                            | 2    |
| 12A    | ROUND HD SUNKEN BOLT | 3/8"*1"                    | 4    |
| 12C    | RIVETNUT             | 3/8"                       | 4    |
| 13     | LATCH                | 85#                        | 2    |
| 13A    | ROUND PH HD SCREW    | 3/16"*3/8"                 | 4    |
| 14     | LATCH BASE           |                            | 2    |
| 14A    | RIVET                |                            | 4    |
| 15     | STRAIN RELIEF        |                            | 2    |
| 16     | STRAIN RELIEF        | PG-13.5                    | 1    |
| 17     | MOTOR CORD           |                            | 1    |
| 18     | POWER CORD           |                            | 1    |
| 19     | OVERLOAD PROTECTOR   | 6A                         | 1    |
| 20     | ON/OFF SWITCH        |                            | 1    |
| 21     | RESET/REMOTE BUTTON  |                            | 1    |
| 22     | CONTROL PANEL        |                            | 6    |
| 22A    | ROUND PH HD SCREW    | 3/16"*3/8"                 | 1    |
| 23     | FILTER BOX           |                            | 2    |
| 24     | LATCH                | 85#                        | 2    |
| 24A    | ROUND HD SUNKEN BOLT | 3/16"*3/8"                 | 4    |
| 25     | LATCH BASE           |                            | 2    |
| 25A    | RIVET                |                            | 4    |
| 26     | HEPA FILTER          | 330*330*100mm              | 1    |
| 27     | HEPA FILTER FASTENER |                            | 4    |
| 28     | VENT INTAKE          |                            | 1    |
| 29     | HANDLE               |                            | 2    |
| 29A    | ROUND HD SUNKEN BOLT | 3/8"*1"                    | 4    |
| 29C    | RIVET NUT            | 3/8"                       | 4    |
| 30     | LATCH BASE           |                            | 2    |
| 30A    | RIVET                |                            | 4    |