

get started

**INSTANT® OMNI® PLUS 18L
AIR FRYER TOASTER OVEN**

USER MANUAL

Instant

Welcome

to your new Instant® Omni® Plus Air Fryer Toaster Oven!

This Instant Air Fryer Toaster Oven can help you cook delicious meals, whether you're air frying, baking, roasting, or just making toast. We hope you fall in love with Instant cooking and enjoy it in your kitchen for years to come!

Get started with your new Air Fryer Toaster Oven!



⚠️ WARNING

Before using your new appliance, read all instructions, including the Important Safeguards. **Failure to follow the safeguards and instructions may result in personal injury and/or property damage.**

CONTENTS

Important safeguards	2
What's in the box	7
Using your Instant Omni Plus	8
Initial setup	11
Cooking	13
Rotisserie cooking	21
Cleaning	25
Troubleshooting	27
Error codes	29
Replacement parts	30
Learn more	31

IMPORTANT SAFEGUARDS

⚠ WARNING

Failure to follow safety instructions may result in personal injury and/or property damage and may void your warranty.

READ ALL INSTRUCTIONS

Before using your new appliance, please read all instructions, including the Safety Information below. Keep this manual for reference.

Placement

- **DO** place the appliance on a countertop only. Always operate the appliance on a stable, non-combustible, level surface.
- **DO** make sure all parts are dry and free of food debris before use.
- **DO NOT** place the appliance or power cord on or close to a gas or electric stovetop or oven. **NEVER** use the appliance on your stove.
- **DO NOT** use the appliance near water, an external heat source or flame.
- **DO NOT** use outdoors. Keep out of direct sunlight.
- **DO NOT** place on anything that may block the vents on the appliance.
- **DO** use extreme caution when moving the appliance. Always let the appliance cool to room temperature before handling or moving.
- **DO NOT** move the appliance if it contains hot oil or other hot liquids.

General Use

- **DO** use the appliances handles when opening the door/basket.
- **DO** use oven mitts when removing accessories and handling hot items.
- **DO** place hot accessories on a heat-resistant surface or cooking plate.
- **DO NOT** touch the appliance's hot surfaces, or any accessories during or immediately after cooking because they will be hot.
- **DO NOT** cover the basket, cooking tray or any part of the appliance with foil. This will cause overheating of the appliance.
- **DO NOT** move the appliance while it is in use.

⚠ WARNING

- **DO NOT** allow children or persons with reduced physical, sensory or mental capabilities to operate this appliance. Close supervision is necessary when any appliance is used by or near children and persons with reduced physical, sensory or mental capabilities. Children should not play with this appliance.
- **DO NOT** use the appliance for anything other than household use. It is not intended for commercial use.
- **DO NOT** leave the appliance unattended while in use.
- **DO NOT** use the appliance for more than 60 minutes in a 2-hour period. Exceptions are when using programs that cook at temperatures under 400° F / 204° C.

Air Frying Cautions

When the air fryer is in operation, hot air is released through the air vents. Keep your hands and face away from the air vents and take extreme caution when removing hot accessories from the appliance.

Failure to do so may result in personal injury and/or property damage.

While cooking, the internal temperature of the appliance reaches several hundred degrees. To avoid personal injury, never place unprotected hands inside the appliance until it has cooled to room temperature.

- **DO** use caution when using cooking containers made of materials other than metal or glass. Failure to do so may result in personal injury, fire and/or property damage.
- **DO** use extreme caution when removing the basket/cooking tray or disposing of hot cooking residue.
- **DO NOT** use a ceramic-coated or stoneware pot for air frying.
- **DO NOT** cover or block the vents while the air fryer is operating. Doing so will prevent even cooking and may cause damage to the appliance. Leave at least 5 in / 13 cm of space around the air fryer when in use.
- **DO NOT** operate the appliance on or near combustible materials such as tablecloths and curtains.
- **DO NOT** use this appliance for deep frying foods.
- **DO NOT** pour oil into the cooking container. Using excess cooking oil could cause fire and result in personal injury and/or property damage.

⚠ WARNING

- **DO NOT** use pressurized, aerosol oil sprays, since they contain chemicals that can damage the non-stick finish of the cooking tray. If needed, spray food lightly with oil with a high smoke point (such as refined avocado oil, safflower oil, refined sunflower oil, refined peanut oil, canola oil and refined coconut oil) from a non-aerosol, pump-style cooking spray before placing in the basket.
- Should the unit emit black smoke during use, press **Cancel** and unplug the appliance immediately. Wait for smoking to stop before removing the lid. Wait for the unit to cool before opening, then clean thoroughly. For further information refer to 'Troubleshooting'.

Overfill During Cooking

- **DO NOT** overfill the unit when air frying. Overfilling may cause food to contact the heating element, which may result in personal injury, fire, and/or property damage. Only place food in a single layer and do not stack food. For units with an air fry basket, do not fill more than 3/4 full. Best air frying results require air circulating through the food.
- **DO NOT** allow food to contact the heating element.

Accessories

- **DO** use only accessories or attachments authorized by Instant Pot Brands. The use of parts, accessories or attachments not recommended by the manufacturer may cause a risk of electric shock or other personal injury, fire and/or property damage.
- **DO NOT** use the included accessories in a microwave, toaster oven, convection or conventional oven, on a ceramic, electric or gas cooktop, or with an outdoor grill.

Care and Storage

- **DO** let the appliance cool to room temperature before cleaning or storage.
- **DO NOT** store any materials in the appliance when not in use.
- **DO NOT** place any combustible materials in the appliance, such as paper, cardboard, plastic, Styrofoam or wood.
- **DO NOT** clean the appliance with metal scouring pads or steel wool. Pieces can break off and touch the electrical parts, causing a risk of shock, burns or other personal injury.

⚠ WARNING

Power Cord

A short power-supply cord is used to reduce the risk resulting from grabbing, entanglement or tripping. **WARNING:** Hot spilled food can cause serious burns.

- **DO** keep appliance and cord away from children.
- **DO NOT** let the power cord hang over edge of tables or counters.
- **DO NOT** let the power cord touch hot surfaces or open flame, including the stovetop.
- **DO NOT** use below-counter power outlets.

This appliance has a 3-prong grounding plug. To reduce the risk of electric shock:

- **ONLY** plug the power cord into a grounded electrical outlet.
- **DO NOT** remove the grounding prong on the electrical plug.
- **DO NOT** use with extension cords, power converters or adapters, timer switches or separate remote-control systems.

Electrical Cautions

The appliance contains electrical components that are an electrical shock hazard. **Failure to follow these instructions may result in electric shock and/or death.**

To protect against electrical shock:

- To disconnect, select **Cancel**, then remove plug from power source. Always unplug when not in use, as well as before adding or removing parts or accessories, and before cleaning. To unplug, grasp the plug and pull from the outlet. **NEVER** pull from the power cord.
- **DO** regularly inspect the appliance and power cord for any signs of damage or fraying.
- **DO NOT** operate the appliance if the power cord or plug is damaged, or after the appliance malfunctions or is dropped or damaged in any manner. For assistance, contact Consumer Care by email at **support@instantpot.com**.
- **DO NOT** attempt to dislodge food while the appliance is plugged in to an electrical outlet as this may lead to electric shock, burns or other personal injury, and/or property damage.

⚠ WARNING

- **DO NOT** attempt to repair, replace or modify components of the appliance, as this may cause electric shock or other personal injury, fire and/or property damage, and will void the warranty. For assistance, contact Consumer Care by email at **support@instantpot.com**.
- **DO NOT** tamper with any of the safety mechanisms, as this may result in personal injury and/or property damage.
- **DO NOT** immerse power cord, plug or the appliance in water or other liquid.
- **DO NOT** clean the appliance by rinsing it under a faucet.
- **DO NOT** use the appliance in electrical systems other than 120 V ~ 60 Hz for North America.

SAVE THESE INSTRUCTIONS

⚠ WARNING

Failure to follow safety instructions may result in personal injury and/or property damage and may void your warranty.

WHAT'S IN THE BOX

Air Fryer Toaster Oven

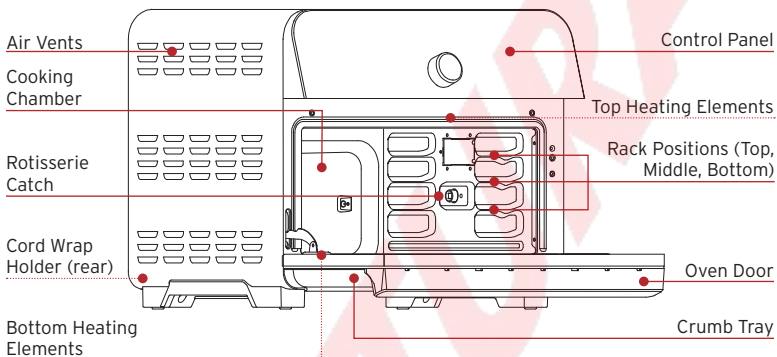

Parts and Accessories

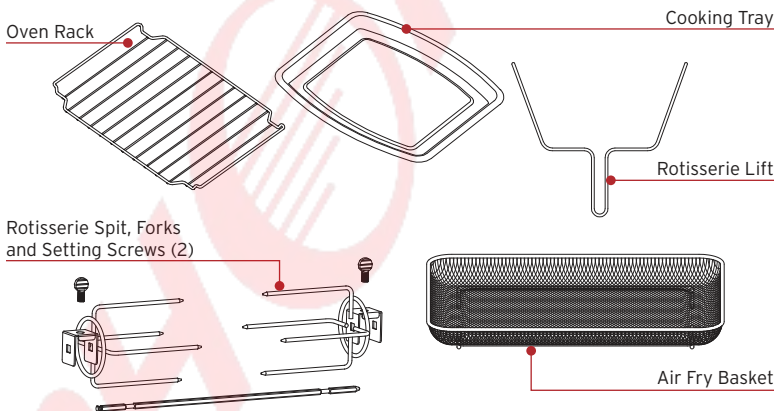

Illustrations are for reference only and may differ from the actual product.

Remember to recycle!

We designed this packaging with sustainability in mind. Please recycle everything that can be recycled where you live.

USING YOUR INSTANT OMNI PLUS

Control panel

We've designed the control panel to be simple to use and easy to read.

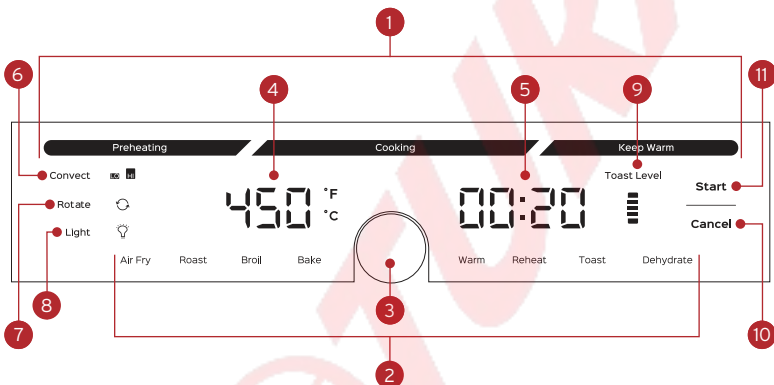

1. Progress Bar
 - Shows cooking status
2. Smart Programs
3. Control Dial
 - Turn to toggle through settings
 - Push to confirm selections
4. Temperature
 - Shows cooking temperature
 - Press to select
5. Time
 - Shows time
 - Shows reminders and error messages
 - Press to select
6. Convect
 - Press to toggle between settings
7. Rotate
 - Press to turn on and off
8. Light
 - Press to turn internal light on and off
9. Toast Level
 - Shows toasting settings
10. Cancel
11. Start

Status messages

The control panel shows information you need to know when using your Instant Omni Plus.

OFF	Unit is ready.
On	Preheat mode.
OPEN	Oven door is open. If door is open over 5 minutes during cooking or 30 seconds during program setting, unit returns to ready mode.
Turn Food	Your food is ready to be turned.
End	Smart Program ended (Keep Warm is off).

Turning the sound On/Off

You can set notification sounds to ON or OFF.

- When in Ready mode, press and hold the **Control Dial** for 5 seconds until the display shows **S On** or **SOFF**.

Error alerts cannot be turned off.

Choosing the temperature scale

You can display cooking temperature in either Fahrenheit or Celsius.

- When in Ready mode, press and hold **Temperature** for 5 seconds until the display shows °F or °C.

Save custom settings

You can set and save custom Time and Temperature settings for Smart Programs.

1. Select the Smart Program you want to set.
2. Press **Temperature** and use the **Control Dial** to adjust the temperature.
3. Press **Time** and use the **Control Dial** to adjust the time.
4. Press **Start** to save the new settings.

The next time you use that Smart Program, the new temperature is used. Adjustments made after cooking begins are not saved.

Reset Smart Programs to original settings

Reset individual Smart Programs

- When in Ready mode, press and hold one Smart Program button for 5 seconds.

The Smart Program's cooking time and temperature are restored to the factory default setting.

Reset all Smart Programs

- When in Ready mode, press and hold **Cancel** until the cooker beeps.

All Smart Program cooking times and temperatures are restored to the factory default setting.

INITIAL SETUP

Unpack

1. Remove your new Air Fryer Toaster Oven from the box.
2. Remove all the packaging material from in and around the oven.
3. Make sure to remove all the accessories from inside the oven chamber.
4. Don't remove the safety warning stickers or the rating label from the Air Fryer Toaster Oven.

Clean before use

1. Wipe the interior with a damp cloth. Use a clean, soft cloth to dry.
2. Wash the accessories with hot water and dish soap. Rinse with warm, clear water and use a soft cloth to dry.

Placement

1. Place your Air Fryer Toaster Oven on a stable, level surface, away from combustible material and external heat sources. Do not place your Air Fryer Toaster Oven on top of another appliance.
2. Make sure to leave at least 5 in / 13 cm of space above and around all sides of the appliance to allow for sufficient air flow.

Test run

Before using your new Air Fryer Toaster Oven for the first time, you must perform a test run to ensure everything is working correctly.

To perform a test run:

1. Plug the Air Fryer Toaster Oven into an electrical outlet. The display will show **OFF**.
2. Open the oven door and insert the cooking tray onto the bottom rack position, but do not add food. Close the door.
3. Press the **Control Dial**.
4. Press **Temperature** and keep the setting at 400°F / 205°C.

5. Press **Time** and use the **Control Dial** to adjust the cooking time to 20 minutes.
6. Press **Start** to begin. The display shows **On** to indicate that preheating has started. When the display shows **Add Food**, just wait 10 seconds for the program to resume.
7. When the display shows **Turn Food**, just wait 10 seconds for the program to resume.
8. After the cooking session is done, the unit beeps and enters **Keep Warm** mode, and then shows **End** when finished. Let the unit cool.

Now you're ready to cook a meal in your Instant Omni Plus!

COOKING

Your Instant Air Fryer Toaster Oven uses rapid air circulation to crisp food when air frying, and works like a convection oven to cook food when baking.

⚠ WARNING

HOT SURFACES

The Air Fryer Toaster Oven will be hot during and after cooking. Always exercise extreme caution when removing food from the hot cooking chamber. Pressing hot surfaces may result in personal injury, and/or property damage.

MUST ALLOW AIR FLOW

To prevent personal injury, do not block air intake or air vents.

What to cook in

Cooking utensil	Use for
Air Fry Basket	Perforated for airflow, use it for air frying most foods, like wings and cauliflower bites. Always place the Air Fry Basket on the Cooking Tray and insert both into the oven, to catch any drippings.
Cooking Tray	Use for baking any food that requires a flat surface, like cookies or fragile fish.
Rotisserie Spit and Forks	Perfect for roasting larger foods like whole chicken and tenderloin (see "Rotisserie cooking" on page 20). Insert the Cooking Tray into the oven in the lowest position to catch any drippings.
Oven Rack	Ideal for baking solid foods, like baked potatoes.
Metal or glass baking dish (not included)	Use to bake soft foods (like bread dough), liquid-based foods (like cake batter) and foods that may drip during cooking (like chicken breasts). Place the baking dish on the oven rack inside the oven, leaving approximately 1"/ 2.5 cm of space around all sides of the baking dish to allow heat to circulate evenly.

Cooking utensil tips

- Always place food right on the Cooking Tray, Oven Rack or Air Fry Basket, without using foil or other coverings.
- Foods will cook slightly faster in the upper rack position and slower in the lower rack position, so you may need to adjust the cooking time accordingly.

About convection cooking

Your Instant Omni Plus oven uses convection hot air circulation in most Smart Programs to cook food faster and more evenly. Each program has a default setting that works best for most foods. In some programs, you can change the convection setting from Low to High for extra crispness.

Smart Program	Default	Options
Air Fry	High	High
Bake	Low	High or Low
Broil	Low	High or Low
Roast	Low	High or Low
Reheat	Low	High or Low
Warm	Low	Low
Dehydrate	Low	High or Low
Toast	Off	None

To cook

Prep

Cut, chop, season, marinate or batter your ingredients according to your recipe.

Cook

For cooking instructions using the Rotisserie function, see page 20.

1. For the Broil, Toast, Dehydrate, Reheat and Warm programs, place your food on the cooking utensil, insert the cooking utensil into the oven, and close the door.
2. For the Air Fry, Roast and Bake programs, insert the cooking utensil (without food) into the air fryer, and close the door.

You'll add food once the unit is preheated.

3. Press the **Control Dial** to wake the unit.
4. Press the button for the Smart Program you want to use.
5. Press **Temperature** and use the **Control Dial** to adjust the temperature as needed.
6. Press **Time** and use the **Control Dial** to adjust the time as needed.
7. Press **Start** to begin. The display shows **On** to indicate that preheating has started.
Note: Adjustments to the cooking time and temperature are saved when you press Start.
8. When the Air Fryer Toaster Oven reaches the target temperature, the cooking countdown timer starts.

Add food

For the Air Fry, Roast and Bake programs:

1. When the unit is preheated, open the door and carefully add your food.
2. Close the door again. Cooking starts.

Turn

The Air Fry, Roast and Bake programs pause during cooking to allow you to turn the food if needed. For programs where turning food isn't needed, the message will not display.

1. Part way through the cooking cycle the display shows **Turn Food**.
*If you do not open the door after **Turn Food** displays, cooking will proceed after 10 seconds.*
2. Open the door and carefully turn, flip, or rotate your food.
3. Close the door again. Cooking continues.

Finish

1. When the Smart Program completes, the Air Fryer Toaster Oven beeps and the display shows **End**.

If you don't open the door, the Air Fryer Toaster Oven beeps every 5 minutes, up to 1 hour, to remind you that cooking has completed.

Air Fry

You can air fry foods like fries, cauliflower bites, wings, nuggets and more.

Setting	Default	Minimum	Maximum
Temperature	400°F / 205°C	180°F / 82°C	450°F / 232°C
Cooking Time	18 minutes (00:18)	1 minute (00:01)	45 minutes (00:45)

To air fry

- Follow the instructions in Cooking on page 13, adjusting the cooking settings as needed.
- Select “Air Fry” as the Smart Program.

Roast

You can roast foods like beef, lamb, pork, poultry, vegetables and scalloped potatoes, for a deliciously tender inside and browned outside. Rotisserie is turned ON automatically when you select Roast. When you roast foods in a pan, turn the Rotisserie OFF by pressing Rotate after you’ve selected Roast.

Setting	Default	Minimum	Maximum
Temperature	365°F / 185°C	180°F / 82°C	450°F / 232°C
Cooking Time	40 minutes (00:40)	1 minute (00:01)	4 hours (04:00)

For more information about Rotisserie cooking, see page 20.

About cooking time

Maximum cooking time depends on the cooking temperature.

Max cooking time	Temperature setting
4 hours	Below 300°F / 149°C
2 hours	Between 300°F and 400°F / 149°C and 204°C
1 hour	Above 400°F / 204°C

To roast

- Follow the instructions in Cooking on page 13, adjusting the cooking settings as needed.
- Select “Roast” as the Smart Program.
- To rotate foods while roasting, see Rotisserie Cooking on page 20.

Broil

Broiling cooks using direct top-down heating, perfect for melting cheese on French onion soup, and nachos.

Setting	Default	Minimum	Maximum
Temperature	450°F / 232°C	350°F / 176°C	450°F / 232°C
Cooking Time	10 minutes (00:10)	1 minute (00:01)	20 minutes (00:20)

To broil

- Follow the instructions in Cooking on page 13, adjusting the cooking settings as needed.
- Select “Broil” as the Smart Program.
- There is no need to turn the food partway through cooking.

Bake

You can bake foods like breads, cakes, chicken breasts or potatoes, using your Air Fryer Toaster Oven instead of heating up your regular oven.

Setting	Default	Minimum	Maximum
Temperature	350°F / 176°C	180°F / 82°C	450°F / 232°C
Cooking Time	40 minutes (00:40)	1 minute (00:01)	4 hours (04:00)

About cooking time

Maximum cooking time depends on the cooking temperature.

Max cooking time	Temperature setting
4 hours	Below 300°F / 149°C
2 hours	Between 300°F and 400°F / 149°C and 204°C
1 hour	Above 400°F / 204°C

To bake

- Follow the instructions in Cooking on page 13, adjusting the cooking settings as needed.
- Select “Bake” as the Smart Program.

Warm

Keep food warm after cooking, so it's the perfect temperature when you're ready to eat.

Setting	Default	Minimum	Maximum
Temperature	170°F / 77°C	170°F / 77°C	300°F / 149°C
Cooking Time	1 hour (01:00)	1 minute (00:01)	2 hours (02:00)

To warm

- Follow the instructions in Cooking on page 13, adjusting the cooking settings as needed.
- Select “Warm” as the Smart Program.

Reheat

Bring the crisp and crunch back to leftover fries and pizza, in just a few minutes.

Setting	Default	Minimum	Maximum
Temperature	300°F / 149°C	120°F / 49°C	360°F / 182°C
Cooking Time	10 minutes (00:10)	1 minute (00:01)	1 hour (01:00)

To reheat

- Follow the instructions in Cooking on page 13, adjusting the cooking settings as needed.
- Select “Reheat” as the Smart Program.

Dehydrate

Dehydrating uses low heat over a long period of time to safely dry out food items, like dried fruit, jerky and dried veggies.

Setting	Default	Minimum	Maximum
Temperature	135°F / 57°C	85°F / 29°C	175°F / 79°C
Cooking Time	8 hours (08:00)	30 minutes (00:30)	72 hours (72:00)

To dehydrate

- Follow the instructions in Cooking on page 13, adjusting the cooking settings as needed.
- Select “Dehydrate” as the Smart Program.
- There is no need to turn the food partway through cooking.

Toast

Toast up to 6 slices of bread or bagel halves at a time, with no turning needed.

Setting	Default	Minimum	Maximum
Number of Pieces	2 pc	1 pc	6 pcs
Darkness Level	3	1 (very light)	5 (very dark)

To toast

1. Open the oven door, insert the oven rack in the middle position, and place your food on the rack.
2. Close the door.
3. Press the **Control Dial** to wake the oven, then press **Toast**.
4. The display shows **2 PC**; press it until it flashes and then turn the **Control Dial** to select the number of slices you're toasting.
5. Press the **Toast Level** field; when it flashes, use the **Control Dial** to select a darkness level.
6. Press **Start** to begin. The display shows **On** to indicate that toasting has started.
7. When the Toast completes, the Air Fryer Toaster Oven beeps and the display shows **End**.
8. Open the door and carefully remove your food.

If you don't open the door, the Air Fryer Toaster Oven beeps every 5 minutes, up to 1 hour, to remind you that cooking has completed.

ROTISSERIE COOKING

You can rotisserie cook during the Air Fry, Bake and Roast programs to rotate food for even cooking and delicious results.

⚠ WARNING

HOT SURFACES

The air fryer oven and rotisserie accessories will be hot during and after cooking. Always use the rotisserie lift to remove the rotisserie spit and exercise extreme caution when removing food from the hot cooking chamber. Always use proper hand protection when handling the hot rotisserie spit. **Touching hot surfaces may result in personal injury, and/or property damage.**

MUST ALLOW AIR FLOW

To prevent personal injury, do not block air intake or air vents.

Placing food on the rotisserie spit and forks

1. Unscrew the 2 setting screws that secure the forks to the rotisserie spit.
2. Remove the forks from the spit. Be careful; the forks are sharp.
3. Push your food onto the spit.
4. Slide the forks onto both ends of the spit, making sure the prongs are inserted into the food item securely on both sides.
5. When the food is in place, tighten the setting screws to hold the forks in place.

Placing the rotisserie spit into the air fryer

1. Open the oven door.
2. Insert the pointed end of the rotisserie spit into the rotisserie catch on the right side of the cooking chamber.

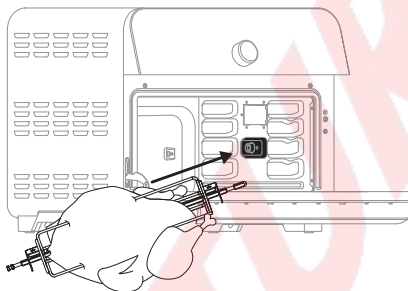

3. Lower the square end of the rotisserie spit into the notch on the left side of the cooking chamber.

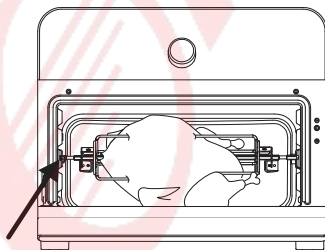

4. Close the oven door.

You're now ready to start rotisserie cooking.

Starting to cook

Always insert rotisserie accessories and food into the cooking chamber before starting the cooking process.

1. Follow the directions above to place your food onto the rotisserie spit and place the rotisserie spit into the oven.
2. Press **Roast, Bake** or **Air Fry**.
3. Press **Temperature** and use the **Control Dial** to adjust the temperature as needed.
4. Press **Time** and use the **Control Dial** to adjust the time as needed.
5. Press **Start** to begin. The display shows **On** to indicate that preheating has started.

Note: Adjustments to the cooking time and temperature are saved when you press Start.

6. Press **Rotate** to start the rotisserie rotation.
7. When the display shows **End**, cooking is finished and you can remove the rotisserie accessories and food.

Removing the rotisserie spit from the air fryer

1. Open the oven door.
2. Position the hooks on the rotisserie lift beneath the left and right arms of the spit.

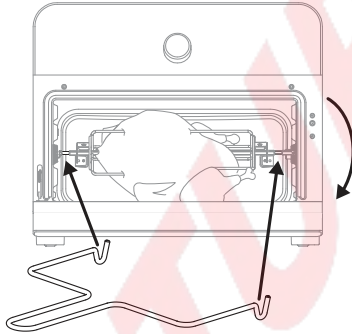

3. Lift the left side of the rotisserie spit slightly, then move the spit to the left to remove it from the catch on the right side.

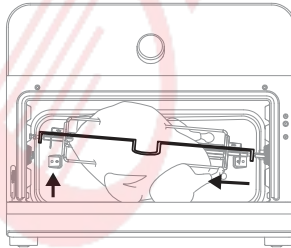

4. Carefully pull the rotisserie spit towards you to remove it from the cooking chamber and place it on a secure, heat-resistant surface.

CLEANING

Clean your Air Fryer Toaster Oven after each use. Always let all parts cool to room temperature before cleaning. Before use or storing, make sure all surfaces are dry.

⚠ WARNING

To prevent electric shock, unplug before cleaning.

DO NOT immerse power cord, plug or the appliance in water or other liquid, which may result in electric shock.

Part	Cleaning instructions
Cooking Tray	<ul style="list-style-type: none">• Dishwasher safe or hand wash.• Avoid using metal utensils or abrasive cleaners when cleaning to prevent damage to the non-stick coating.
Air Fry Basket	<ul style="list-style-type: none">• Dishwasher safe or hand wash.• For best results when handwashing, use a bristled brush instead of a sponge or cloth.
Oven Rack	<ul style="list-style-type: none">• Dishwasher safe or hand wash.• Remove for cleaning.
Rotisserie Spit, Forks and Screws	<ul style="list-style-type: none">• Dishwasher safe or hand wash.• Place small parts together in a small mesh bag for dishwasher cleaning.
Rotisserie Lift	<ul style="list-style-type: none">• Dishwasher safe or hand wash.• Clean as needed.
Crumb Tray	<ul style="list-style-type: none">• Dishwasher safe or hand wash.• Remove for cleaning.• To prevent smoking, make sure grease and food debris is fully removed.

Part	Cleaning instructions
Cooking chamber	<ul style="list-style-type: none">• Clean with a damp cloth and mild dish soap.• For baked on grease residue, use a commercial oven cleaner.• Always check the heating coil and cooking chamber walls for oil spatter and food debris, and clean as needed.• Ensure the heating coil is dry before turning on the Air Fryer Toaster Oven.
Exterior	<ul style="list-style-type: none">• Clean with a damp cloth and mild dish soap.• After cleaning, wipe with a dry cloth to prevent streaking.
Power cord	<ul style="list-style-type: none">• Use a barely-damp cloth to wipe any particles off cord.

TROUBLESHOOTING

Problem	Cause	Solution
Appliance will not turn on	The appliance is not properly plugged in.	Make sure the power cord is plugged into the outlet firmly.
	Outlet is not powered.	Plug another appliance into the same outlet to test the circuit.
	The oven door is not fully closed.	Make sure the door is fully closed.
Black smoke is coming from the appliance	Using an oil with a low smoke point.	Cancel the Smart Program, unplug the appliance and allow it to cool to room temperature. Choose an oil with a high smoke point, such as avocado oil (refined), safflower oil, sunflower oil (refined), peanut oil (refined), canola oil, coconut oil (refined).
	Food residue on the heating coil, in the cooking chamber or on the accessories.	Cancel the Smart Program, unplug the appliance and allow it to cool to room temperature. Remove all accessories from the cooking chamber and clean the cooking chamber and all accessories thoroughly.
	Appliance malfunction.	Contact Consumer Care. Do not attempt to repair the appliance.

Problem	Cause	Solution
White smoke is coming from the appliance	Cooking foods with a high fat content, such as bacon, sausage, and hamburger.	Avoid air frying foods with a high fat content. Check the cooking chamber for excess oil and/or fat and carefully remove as needed before air frying.
	Water is vaporizing, producing thick steam.	Pat dry moist food ingredients before air frying. Do not add water or other liquid to the cooking chamber when air frying.
	Seasoning on food has blown into element.	Be mindful when seasoning food. Spray vegetables and meats with oil before seasoning to help the seasoning stick.

ERROR CODES

If the control panel displays an error code from this list, there is an issue with your Air Fryer Toaster Oven. Here are the actions you should take to fix the problem. Do not attempt to repair the appliance.

Problem	Cause	Solution
E1	Temperature sensor open circuit.	Contact Consumer Care.
E2	Short circuit.	Contact Consumer Care.
E3	Abnormal circuit.	Contact Consumer Care.
E6, E7, E8	Abnormal function.	Contact Consumer Care.

REPLACEMENT PARTS

We offer genuine replacement parts for your Instant Omni Plus Air Fryer Toaster Oven, if you need them. Visit www.instantpot.com to order.

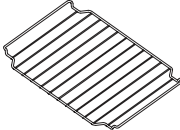
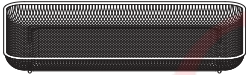
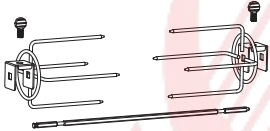
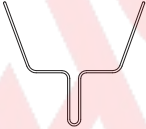
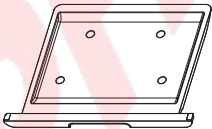
	Part	Part number
	Cooking Tray	310-0131-01
	Oven Rack	310-0129-02
	Air Fry Basket	310-0130-01
	Rotisserie Rod Rotisserie Screws (2x) Rotisserie Forks (2x)	310-0126-01 310-0127-01 310-0128-01
	Rotisserie lift	310-0132-01
	Crumb Tray SS Deco Crumb Tray Black Deco	310-0133-01 310-0134-01
	Manual	399-1271-03US

LEARN MORE

There's a whole world of Instant cooking information and help just waiting for you. Here are some of the most helpful resources.

Register your product

Instantpot.com/register

Contact Consumer Care

In the Instant Connect™ app
Instantpot.com/customer-care-center
support@instantpot.com

Download the Instant Connect™ app

Discover guided cooking and recipes
Available at iOS and Android app stores

Cooking charts and more recipes

Instantpot.com

How-to videos, tips and more

Instantpot.com

Replacement parts and accessories

Instantpot.com

Join the community



Product specifications

Model	Volume	Wattage	Power
Instant Omni Plus 18	19 Quarts 18 Litres	1800 W	120 V/60 Hz

⚠ WARNING

DO NOT place this appliance on or close to a gas or electric burner, or inside an oven. Always operate this appliance on a stable, non-combustible, level surface, such as a kitchen countertop.



In Canada, distributed by
Instant Pot Brands
199 Bay Street, Suite 4000
Toronto, ON M5L 1A9 Canada

In U.S., distributed by
Instant Pot Brands
3025 Highland Parkway, Suite 700
Downers Grove, IL 60515 U.S.

instantpot.com

© 2024 Instant Pot Brands
140-4002-01, 140-4002-02

Art release date
04/19/2024

INSTANT and OMNI
are registered trademarks
of Instant Pot Brands