

LENOXX

www.lenoxx.com.au

1300 666 848

LenoxxElectronics LenoxxElectronics

service@lenoxx.com.au

Function Description

Three types of sports to improve the Kids' exercise skills.



Football can improve the kids' physical coordination and teamwork.



Basketball can improve the kids' coordination between their eyes and the hands.



Golf can exercise the hands and the waist, feeling the noble sports.

There are three keys on the board to switch three patterns:

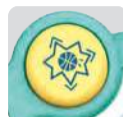

Pattern "Games", The kids could learn to listen and action in the pattern. The kids do after the order and improve the interaction ability and the concentration.

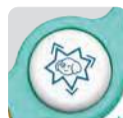

Pattern "Movement", The kids can play any types of the sports follow the sounds and music, the LED board appears different pictures. The kids can enjoy the rhythm and relax themselves.



Pattern "Experience", in this pattern, the kids can see the scores from the LED board while playing basketball\football\golf. Encourage the kids love exercise to keep healthy.



The hands of the clock can be moved at will, which is convenient for parents to teach children about time.



Turning gears can exercise children's sales flexibility, inspire children to think about the principle of gears driving gears, and cultivate children's thinking ability.

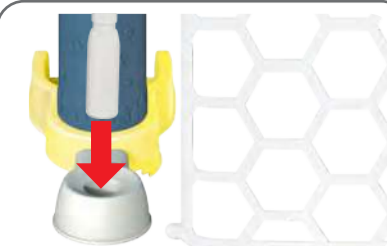

The ball club can be stored in the hole to avoid disorderly placement.



Small cards can be turned up to cultivate children's curiosity



Power switch / volume adjustment



Press and hold the button at the back of the screen to pull the screen up or down.



Warm tips: Golf does not have counting and voice functions. In the power on state, there is no function operation for 50 seconds to play the voice reminder, and no function operation for 2 minutes to enter the energy-saving state. Press any function key can be waked up again.

Battery installation diagram:

This product is powered by three 1.5V "AA" batteries. Open the battery cover on the back of the basketball board, install three DC 1.5VAA batteries into the battery holder, then cover the battery cover and lock the screws.

Note: the positive and negative poles of the battery should not be misplaced!

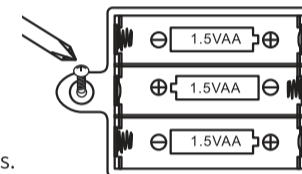

Use 3 x 1.5V AA batteries. Battery not included.

Boon®

DREAMING Party 3 in 1 sports toy USE MANUAL

Manual contains important information and should be retained



NO:1908C

Design by our hearts, bring your baby joy and happiness

Cultivate athletic talent Body muscle training General movement training Hand-eye coordinated development

Brief introduction

- Three kinds of sports experiences
- Stimulate athletic potential
- Human-computer interaction experience
- Concentration cultivated training
- LED high-tech design
- Humanized functional design

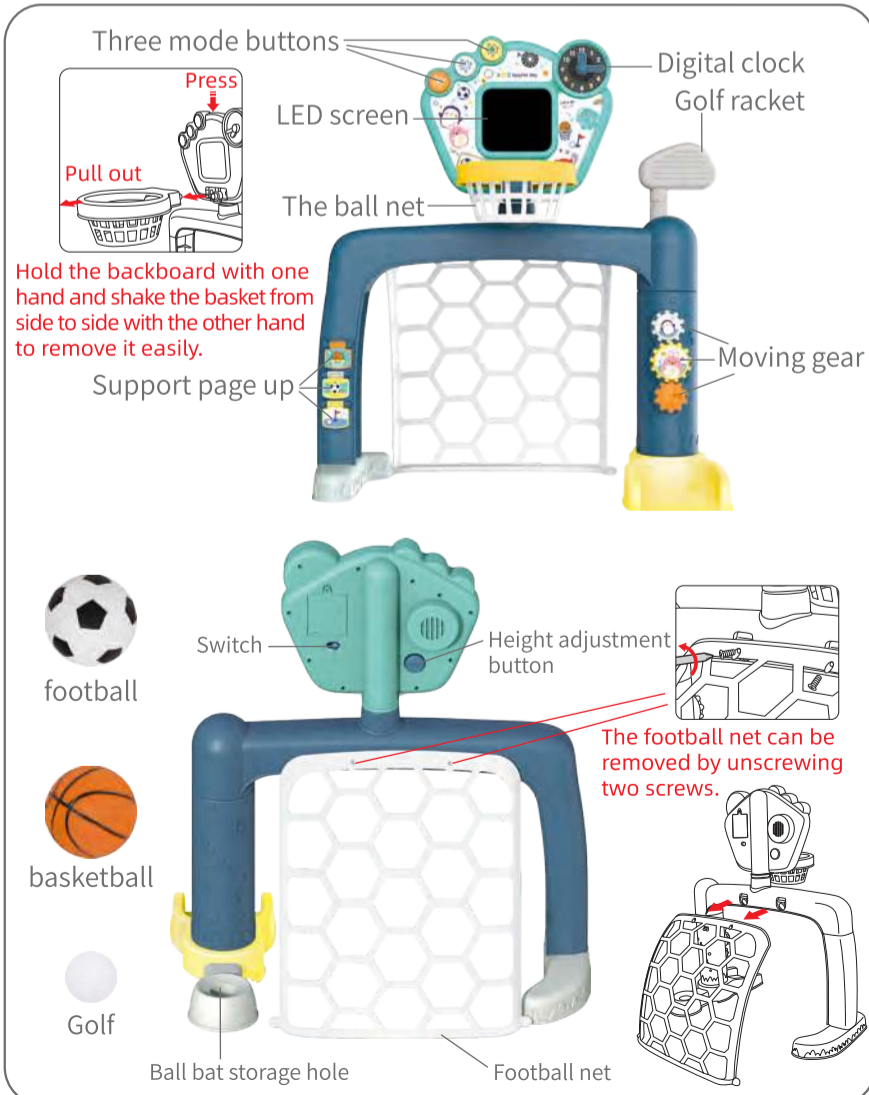

Hold the backboard with one hand and shake the basket from side to side with the other hand to remove it easily.

The football net can be removed by unscrewing two screws.

Product installation diagram

This toy is intended to be assembled by the adult.

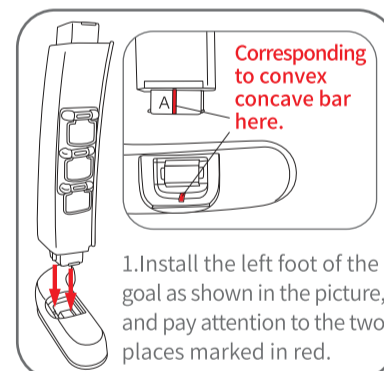

1. Install the left foot of the goal as shown in the picture, and pay attention to the two places marked in red.

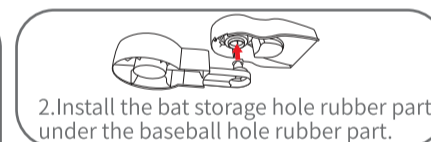

2. Install the bat storage hole rubber part under the baseball hole rubber part.

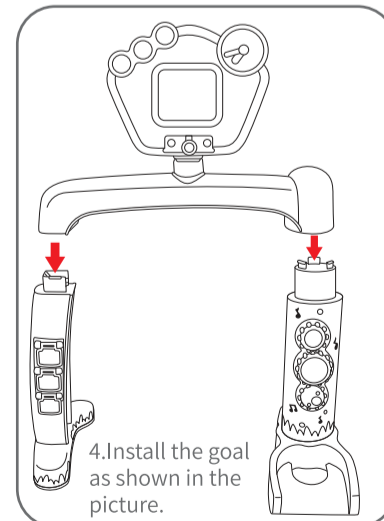

3. Install the right foot of the goal as shown in the picture, and pay attention to the four corresponding places marked in red.

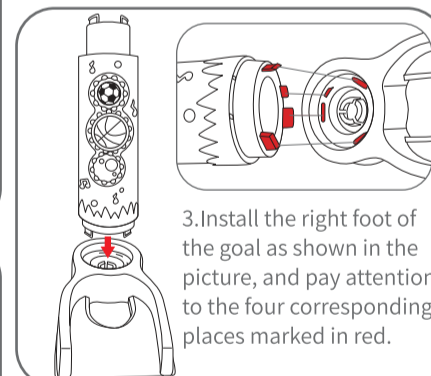

4. Put on the basket.

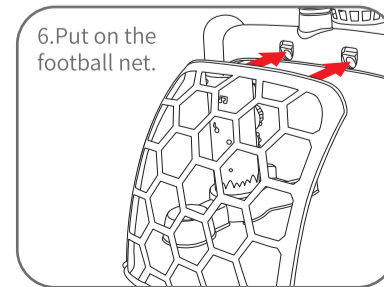

5. Put in the baseball bat, done!

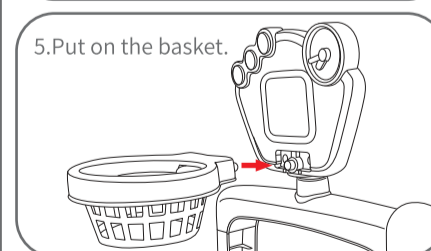

6. Put on the football net.

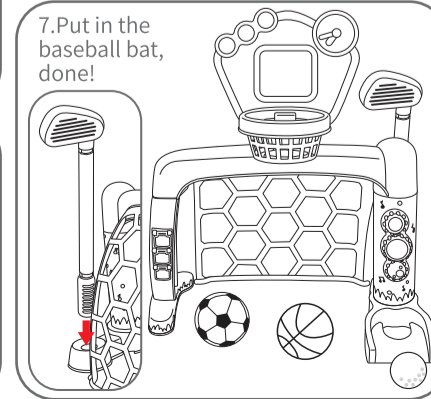

7. Put in the baseball bat, done!