

**LUCCI AIR
ARIA CTC
CEILING FAN**

- **INSTALLATION**
- **OPERATION**
- **MAINTENANCE**
- **WARRANTY INFORMATION**

CAUTION
**READ INSTRUCTIONS CAREFULLY FOR SAFE
INSTALLATION AND FAN OPERATION.**

THANK YOU FOR PURCHASING

Thank you for purchasing this quality Lucci product. To ensure correct function and safety, please read and follow all instructions carefully before assembly, installation and use of this ceiling fan. Please keep instructions for future reference.

SAFETY PRECAUTIONS

1. The appliance is not intended for use by persons (including children) with reduced physical, sensory or mental capabilities, or lack of experience and knowledge, unless they have been given supervision or instruction concerning the use of the appliance by a person responsible for their safety.
2. Children should be supervised to ensure that they do not play with the appliance.
3. An all-pole disconnection switch must be incorporated into the fixed wiring, in accordance with local wiring rules.

IN AUSTRALIA**WARNING:**

**FOR SAFE USE OF THIS FAN AN ALL-POLE DISCONNECTION
MUST BE INCORPORATED INTO THE FIXED WIRING IN
ACCORDANCE WITH THE WIRING RULES.**

As outline in clause 7.12.2 of AS/NZS 60335-1 for meeting the minimum electrical safety of this standard.

Please note warranty will be void if installation is without a means for an all-pole disconnection incorporated in the fixed wiring in accordance with the wiring rules.

Example: If a fan is connected to a circuit that can be isolated via an



all-pole safety switch at the switchboard, then this is considered to be an all-pole disconnection to the ceiling fan electrical circuit, meeting the requirements of clause 7.12.2 of AS/NZS 60335.1.

A single-pole switch on the active of the receiver input of remote control must also be included in the wiring, and located the same room as the ceiling fan.



4.  Do not dispose of electrical appliances as unsorted municipal waste, use separate collection facilities. Contact your local government for information regarding the collection systems available. If electrical appliances are disposed of in landfills or dumps, hazardous substances can leak into the ground water and get into the food chain, damaging your health and well-being.
5. The structure to which the fan is to be mounted must be capable of supporting a weight of 21kg.
6. The fan should be mounted so that the blades are more than 2.1 m above the floor.
7. This fan is suitable for indoor, alfresco and coastal areas where the fan is fully undercover with a minimum of 1 walls. This fan is not waterproof. When installed in an alfresco or coastal area, the ceiling fan must be positioned in a location protected from water, wind and dust. Exposure to these elements will void the warranty. Mounting the fan in a situation where it is subject to water or moisture is dangerous and may increase the risk of damage, injury or electrical shock and will void the warranty.
8. Must be assembled and installed by a licensed electrician.
9. The replacement of parts of the safety suspension system device shall be performed by the manufacturer, its service agent or suitably qualified persons.
10. The fixing means for attachment to the ceiling such as hooks or other devices shall be fixed with a sufficient strength to withstand 4 times the weight of the ceiling fan; that the mounting of the suspension system shall be performed by the manufacturer, its service agent or suitably qualified persons.
11. **WARNING:** If unusual wobbling or oscillating movement is observed, immediately stop using the ceiling fan and contact the manufacturer, its service agent or suitably qualified persons.



BEFORE INSTALLATION

- Unpack your ceiling fan carefully. Remove all parts and hardware.
- Lay out all the components on a smooth surface and make sure there are no components missing before assembling. If parts are missing, return the complete product to the place of purchase for inspection or replacement.
- Check whether the ceiling fan has been damaged during transport. Do not operate/install any product which appears damaged in any way. Return the complete product to the place of purchase for inspection, repair or replacement.
- Examine all parts, you should have the following:

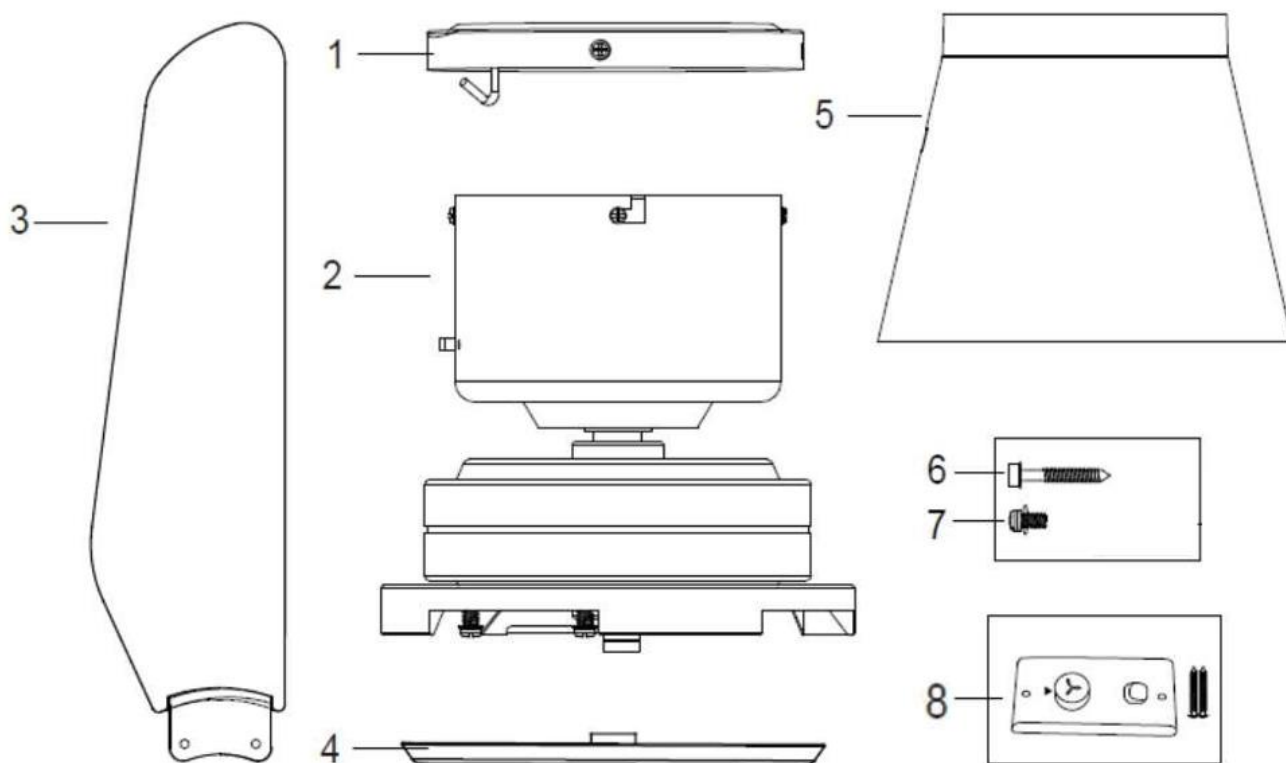

Fig. 1

1.	Mounting bracket x1 set	5.	Motor housing x 1
2.	Motor assembly x 1	6.	Mounting screws x 4
3.	Blades x4 pcs	7.	Spare motor screw for blade x1 pcs
4.	Bottom cover x 1	8.	Wall switch x 1 set

INSTALLING THE MOUNTING BRACKET

- The ceiling fan must be installed in a location so that the blades are spaced 300mm from the tip of the blade to the nearest objects or walls.
- Install the hanging bracket to the ceiling joist or structure that is capable of carrying a load of at least 21kg, with the 4 long screws provided. Ensure at least 30mm of the screw is threaded into the support. (Fig. 2)

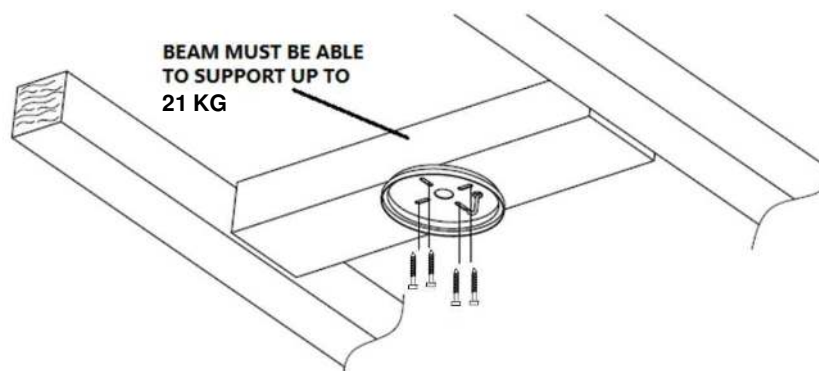

Fig. 2

NOTE: The bracket screws provided are for use with wooden structures only. For structures other than wood, the appropriate screw type **MUST** be used. Ensure the screws used are suitable for the mounting surface and the surrounding environment.

ANGLED CEILING INSTALLATION

This fan hanging system **DOES NOT** support a degree angled ceiling installation.

HANGING THE FAN TO MOTOR ASSEMBLY

- Install the motor housing (1) onto the motor assembly. (Fig.3)
- Lift the fan assembly up to the mounting bracket. Hang the fan assembly onto the J-hook (2) of the mounting bracket. (Fig.4)
- Complete the electrical wiring according to the 'ELECTRICAL WIRING DIAGRAM' section below.

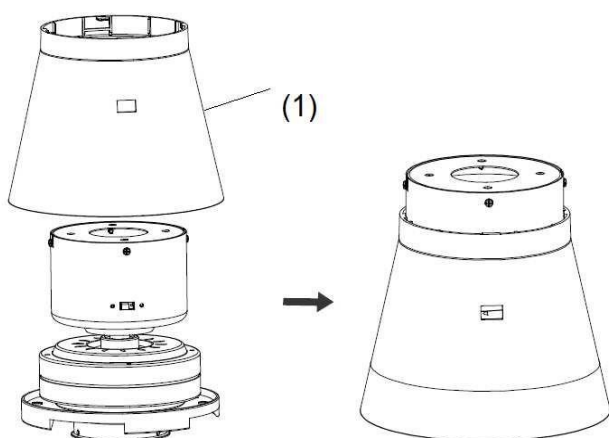

Fig. 3

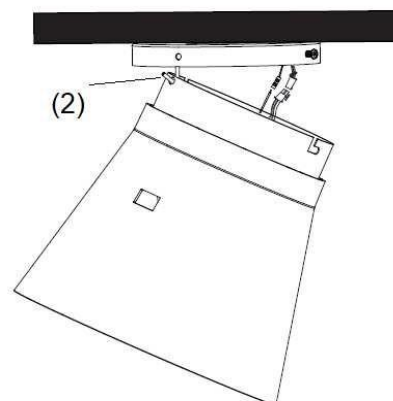

Fig. 4



ELECTRICAL WIRING DIAGRAM

WARNING: FOR YOUR SAFETY ALL ELECTRICAL CONNECTIONS MUST BE UNDERTAKEN BY A LICENSED ELECTRICIAN.

NOTE: AN ADDITIONAL ALL POLE DISCONNECTION SWITCH MUST BE INCLUDED IN THE FIXED WIRING.

USE WITH WALL SWITCH WIRING DIAGRAM:

Ensure the motor earth wire is connected to the single earthing terminal block "2" in the diagram below. (Fig. 5)

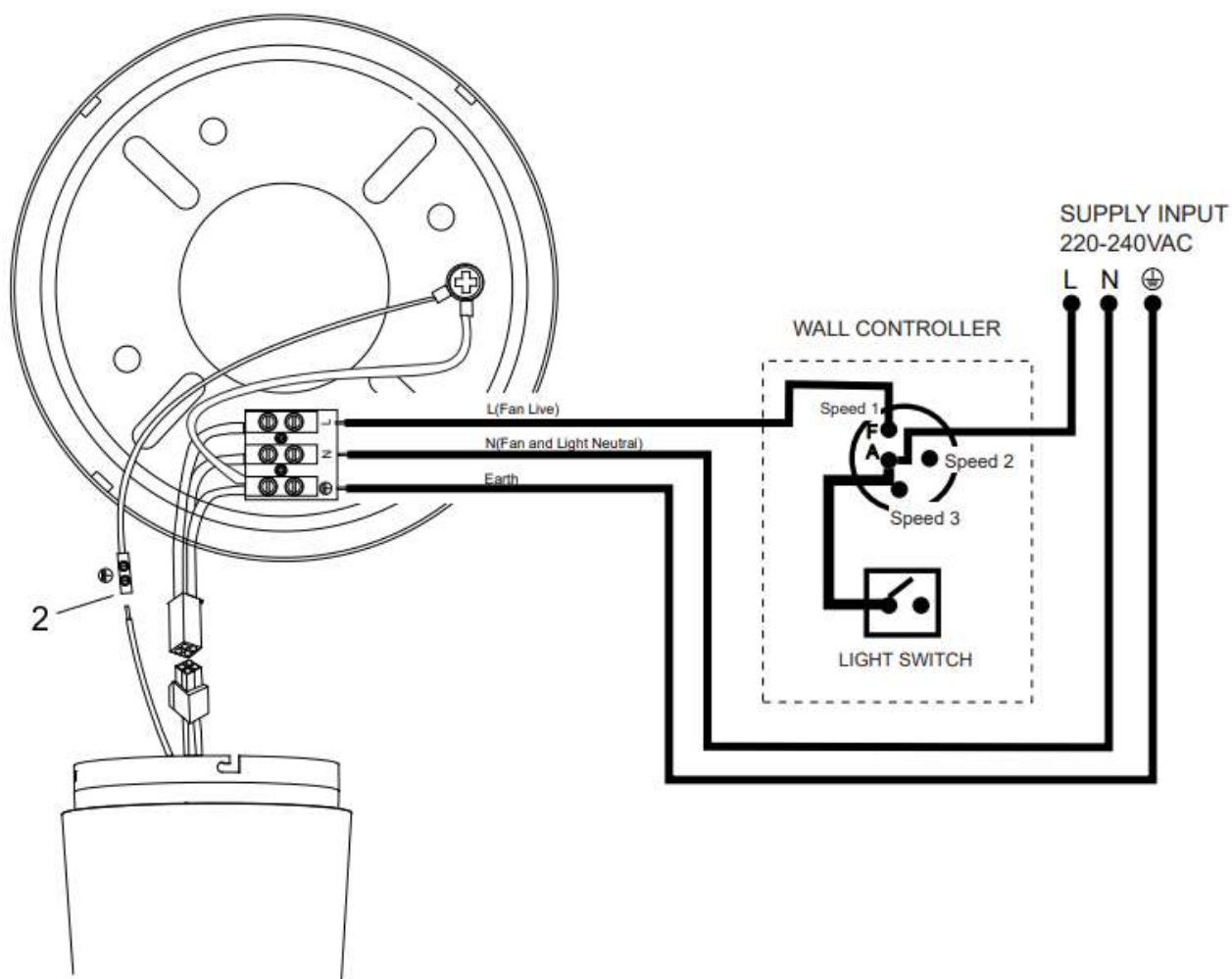

Fig. 5

USE WITH REMOTE WIRING DIAGRAM: (REMOTE sold separately)

Ensure the motor earth wire is connected to the single earthing terminal block "2" in the diagram (Fig. 6 and Fig.7)

1/ Remote without plugs (manual wiring)

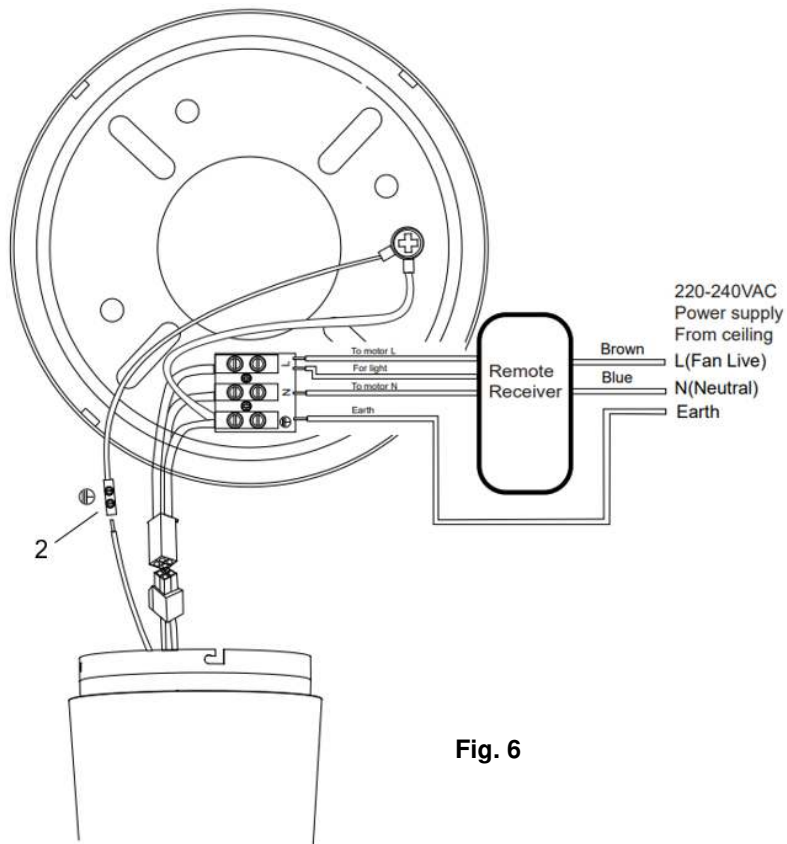

Fig. 6

2/ Remote with plugs (using quick connectors)

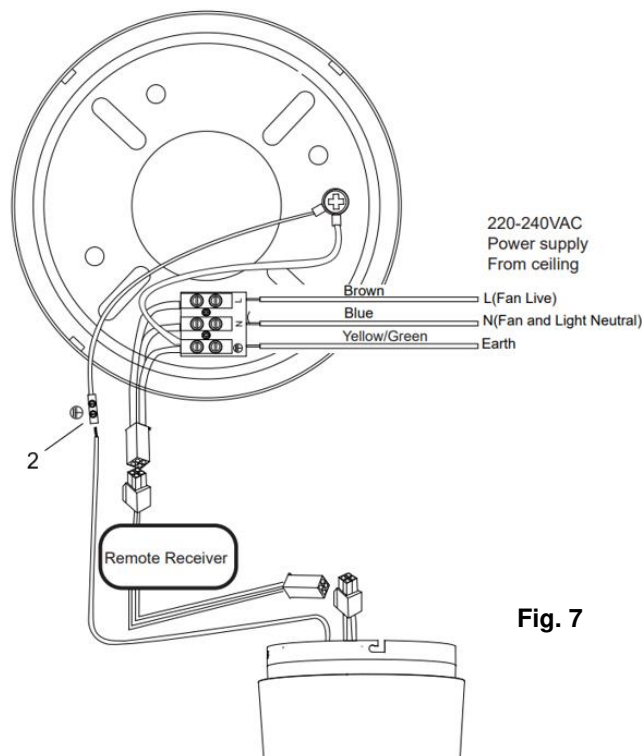

Fig. 7

INSTALL THE FAN ASSEMBLY TO THE MOUNTING BRACKET

- After completing the electrical connection at the mounting bracket terminal block, connect the ceiling fan wiring via the quick connector plug.
- Ensure the earth wiring is secure and correct, by performing an earthing continuity test from the fan's accessible metal body back to the earth terminal at the terminal block on the mounting bracket.

Install the fan assembly to the mounting bracket (Fig.8):

- Loosen two canopy screws (1) and remove from the mounting bracket.
- Loosen two canopy screws with star washer (2) by half thread from the mounting bracket. (For L-shape slot on canopy to be mounted).
- Lift the hanging canopy of the fan assembly up to the mounting bracket and let the L-shape slot on the hanging canopy go through the two canopy screws with star washer (2).
- Turn the hanging canopy until it locks in place at the end section of the L-shape slot, ensure the star washer are between the hanging canopy (3) and screw head. Secure it by tightening the two canopy screws with star washer (2).
- Secure and tighten the canopy screws (1) to the mounting bracket. The hanging canopy (3) shall have 4 screws (1) & (2) in total. Avoid damaging the electrical wiring prepared previously when hanging the canopy.
- Finally attach the canopy cover (4) to the mounting bracket, secure it by pushing the hooks of the canopy cover into the slot holes of the hanging canopy and turn it anti clockwise.

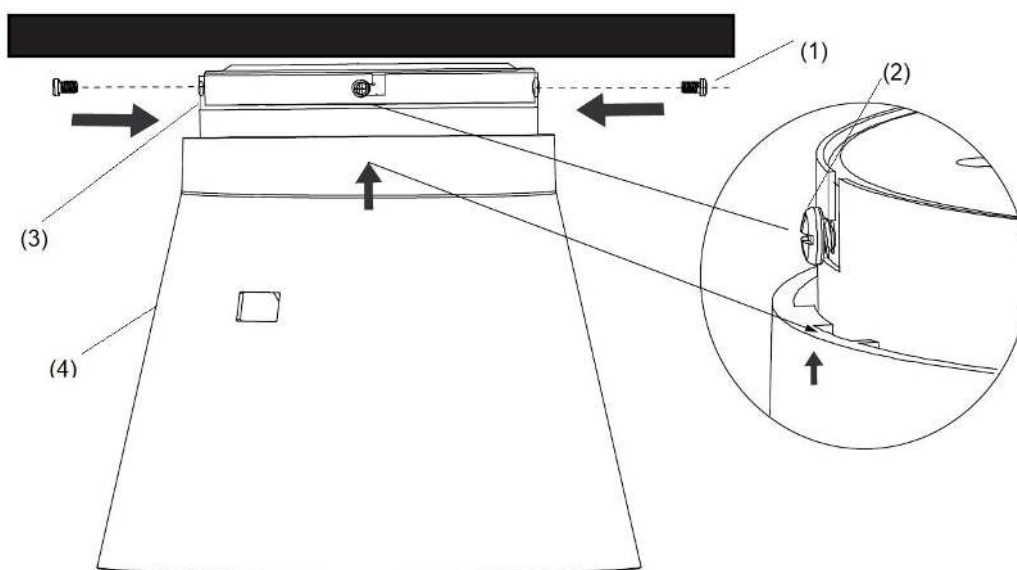

Fig. 8



INSTALLING THE FAN BLADE AND LIGHT KIT**INSTALLING THE FAN BLADE AND LIGHT KIT****BLADE ATTACHMENT (Fig.9)**

1. Before installing the blades, remove the blade screws and flat washers from the bottom of fan motor.
2. Align the 2 holes on the blade with the 2 holes on the rotating member of fan motor assembly and using the 2 blade screws in step 1, to secure the blade to the fan motor assembly.
Ensure all screws are tightened evenly to reduce the chance of warping or unbalancing. Take care not to over tighten the screws, as this can damage the blades.
3. Once completed, repeat the process on the remaining blades.

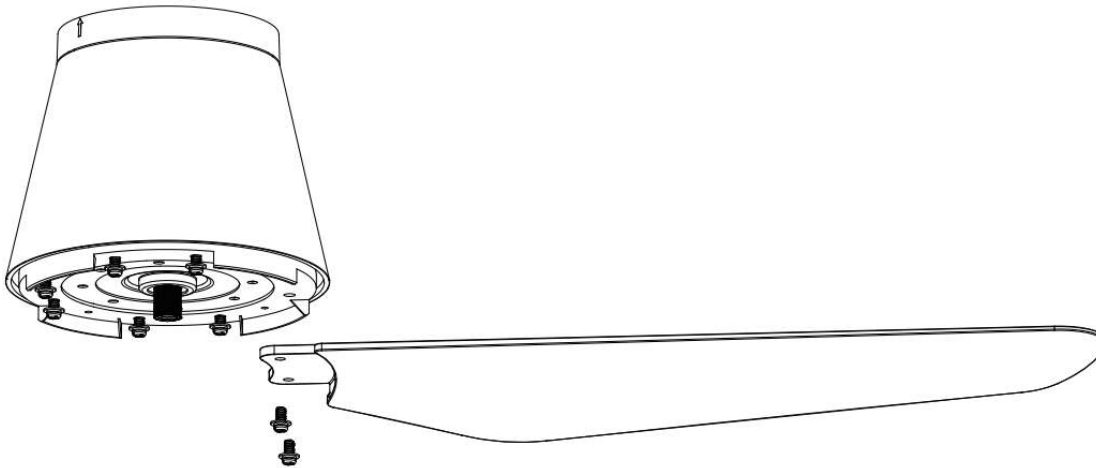

Fig. 9

INSTALLING THE BOTTOM COVER (FOR FAN WITHOUT LIGHT FIG.10)

Secure the bottom motor cover to the fan by turning it clockwise.

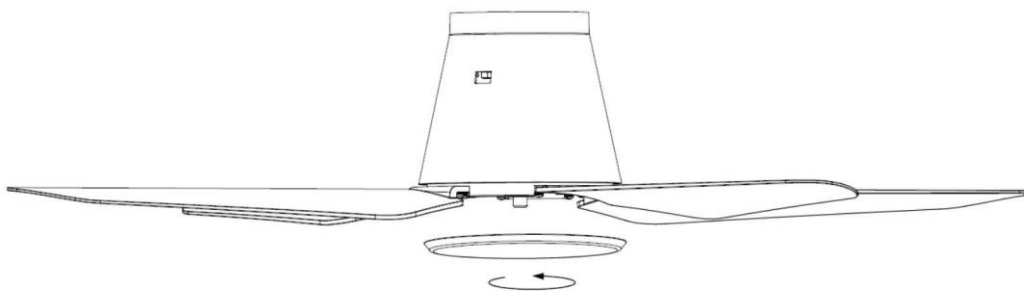

Fig. 10



USING YOUR CEILING FAN

FAN WALL CONTROL

Turn on the power and check the operation of the fan.

- OFF Position – Fan off
- 3rd Position – Low fan speed
- 2nd Position – Medium fan speed
- 1st Position – High fan speed

LIGHT CONTROL

- Toggle Switch – On/off
(The fan is without light)

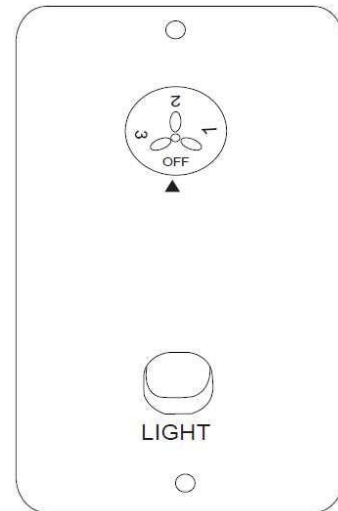

Fig. 11

REVERSING SWITCH

Your ceiling fan can operate in either summer or winter mode.

SUMMER Mode: The reverse switch shall be in the SUMMER position to make the fan rotate in an anticlockwise direction. The airflow will be directed downwards, for cooling in summer.

WINTER Mode: The reverse switch shall be in the WINTER position to make the fan rotate in a clockwise direction. The airflow will be directed upwards assisting in the circulation of warm air, for energy conservation in winter.

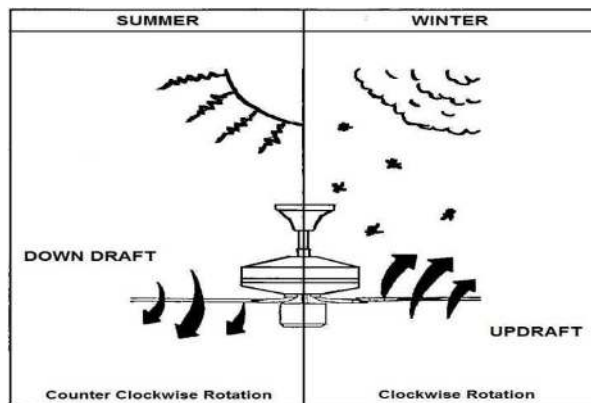
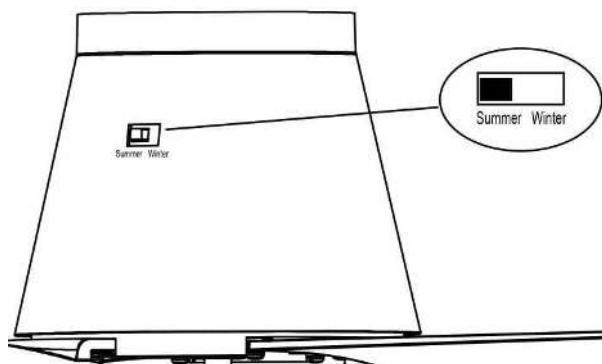

Fig. 12

AFTER INSTALLATION

WOBBLE:

NOTE: ceiling fans tend to move during operation due to the fact that they are mounted on a rubber grommet. If the fan was mounted rigidly to the ceiling it would cause excessive vibration. Movement of a few centimetres is quite acceptable and DOES NOT suggest any problem.

TO REDUCE THE FAN WOBBLE: Please check that all screws which fix the mounting bracket and down rod are secure.

NOISE:

When it is quiet (especially at night) you may hear occasional small noises. Slight power fluctuations and frequency signals superimposed in the electricity for off-peak hot water control, may cause a change in fan motor noise. This is normal. Please allow a 24-hour “settling-in” period, most noises associated with a new fan disappear during this time.

The manufacturer’s warranty covers actual faults that may develop and NOT minor complaints such as hearing the motor run – All electric motors are audible to some extent.

CARE & CLEANING

NOTE: Always turn OFF the power at the mains switch before performing any maintenance or attempting to clean your fan.

- Every 6 months periodic cleaning of your ceiling fan is the only maintenance required. Use a soft brush or lint free cloth to avoid scratching the paint finish. Please turn off electricity power when you do so.
- Do not soak or immerse your ceiling fan in the water or other liquids. It could damage the motor or the blades and create the possibility of an electrical shock.
- Ensure that the fan does not come in contact with any organic solvents or cleaners.
- To clean the fan blade, wipe with only a damp clean cloth with NO organic solvents or cleaners.
- The motor has a permanently lubricated ball bearing so there is no need to oil.

TECHNICAL INFORMATION

Fan	48” ARIA CTC fan without light	52” ARIA CTC fan without light
Fan Models	SKU#212999/SKU#213000	SKU#213129
Rated Voltage	220-240V~ 50Hz	
Rated Wattage (Motor)	50W	
Rated wattage (Lamp)	N/A	
Battery for remote	N/A	
Weight	5.0kg	5.1kg
Canopy Dimensions	H:95mm Dia:130mm	

This fan is suitable for indoor, alfresco and coastal areas where the fan is fully undercover with a minimum of 1 walls. This fan is not waterproof. When installed in an alfresco or coastal area, the ceiling fan must be positioned in a location protected from water, wind and dust. Exposure to these elements will void the warranty. Mounting the fan in a situation where it is subject to water or moisture is dangerous.

LUCCI CEILING FAN WARRANTY DETAIL

LUCCI WARRANTY CONTACT INFORMATION:

Online Warranty Form: <https://www.beaconlighting.com.au/warranty-claims>

Email: warranty@beaconlighting.com.au

Lucci Fan Warranty Hotline: (Free Call) 1800 602 243

THIS WARRANTY IS VALID IN AUSTRALIA ONLY

In the event of service being required, please call the Lucci Fan Warranty Hotline on 1800 602 243 between 9am & 5pm (EST) Monday to Friday. Please make sure you have all the ceiling fan details filled out at the end of the manual before making the call.

Every Lucci ceiling fan is thoroughly inspected and tested before being released for sale. In addition to any warranty rights or conditions under statutory regulations, Lucci warrants all of its ceiling fans against defective workmanship and faulty materials for two (2) years from the date of purchase. Following this, an additional seven (7) years motor replacement warranty applies. Lucci undertakes, at its option, to repair or replace, free of charge, each product or part thereof on condition that;

1. The fan or relevant part has not been subjected to misuse, neglect, or been involved in an accident.
2. The repairs are not required as a result of normal wear and tear.
3. The product was installed by a licensed electrical contractor.
4. A copy of the original receipt of purchase is presented.
5. 12 month warranty applies when used in any non-domestic applications.
6. This warranty does not cover stains, scratch and scuff marks, or dents if the product is purchased through a factory outlet or to refurbished items.

Our goods come with guarantees that cannot be excluded under the Australian Consumer Law. You are entitled to a replacement or refund for a major failure and compensation for any other reasonably foreseeable loss or damage. You are also entitled to have the goods repaired or replaced if the goods fail to be of acceptable quality and the failure does not amount to a major failure.

Lucci Design cannot be held responsible for any repair other than those carried out by it or one of its Authorised Service Agents. Please keep this warranty information in a safe place. This information must be produced in the event of service being required.

Distributed by:

Beacon Lighting
140 Fulton Drive
Derrimut, Victoria, 3026
Australia
Ph +613 9368 1000
Email: warranty@beaconlighting.com.au

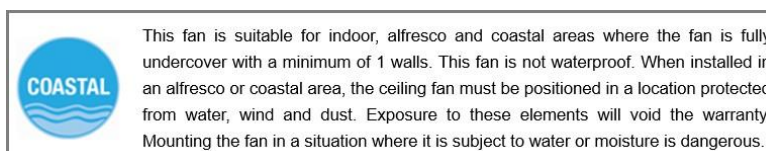

CEILING FAN WARRANTY INFORMATION

LUCCI WARRANTY CONTACT INFORMATION:

Online Warranty Form: <https://www.beaconlighting.com.au/warranty-claims>

Email: warranty@beaconlighting.com.au

Lucci Fan Warranty Hotline: (Free Call) 1800 602 243

Complete and retain this form for your personal records and warranty purposes.

NAME.....

ADDRESS.....

.....POSTCODE.....

MODEL NUMBER.....

(PO# + DATECODE Sticker here)

PO NUMBER or DATECODE

DATE OF PURCHASE.....

INSTALLING LICENSED ELECTRICIAN.....

.....

LICENCE No.....

ATTACH PROOF OF PURCHASE HERE

THIS COMPLETED DETAIL PAGE SHOULD BE PRODUCED AND SENT TO THE WHOLESALE OR THEIR AUTHORISED AGENTS BEFORE OBTAINING WARRANTY SERVICE



This fan is suitable for indoor, alfresco and coastal areas where the fan is fully undercover with a minimum of 1 walls. This fan is not waterproof. When installed in an alfresco or coastal area, the ceiling fan must be positioned in a location protected from water, wind and dust. Exposure to these elements will void the warranty. Mounting the fan in a situation where it is subject to water or moisture is dangerous.