

Mastercraft™

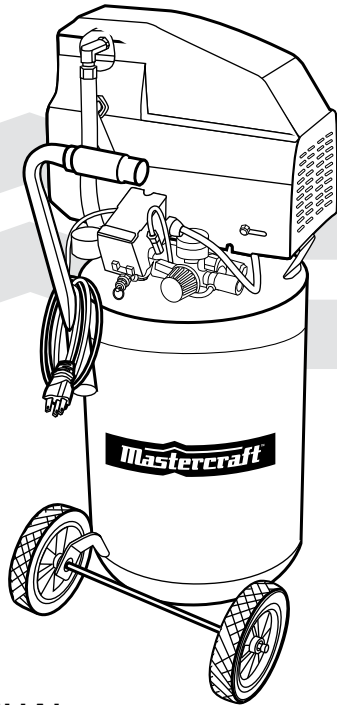

INSTRUCTION MANUAL AIR COMPRESSOR 11-GALLON (41.6 L)

058-8386-8

Version: 03

If any parts are missing or damaged, or if you have any questions, please call our toll-free helpline at 1-800-689-9928.



Read and understand this instruction manual thoroughly before using the product. It contains important information for your safety as well as operating and maintenance advice.

Keep this instruction manual for future use. Should this product be passed on to a third party, this instruction manual must be included.

An English version of this manual is available online at:

www.canadiantire.ca/manuals

中文版說明書請參照：

www.canadiantire.ca/manuals



Intertek
3181069

Quick Start Guide

AIR COMPRESSOR 11-GALLON (41.6 L) - 058-8386-8

Mastercraft

STEP 1

Set the pressure switch to the **OFF** position.

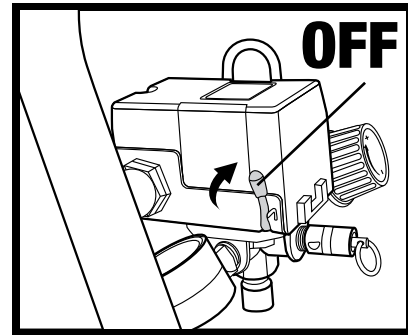

STEP 2

Turn the air pressure regulator knob counter-clockwise until it stops.

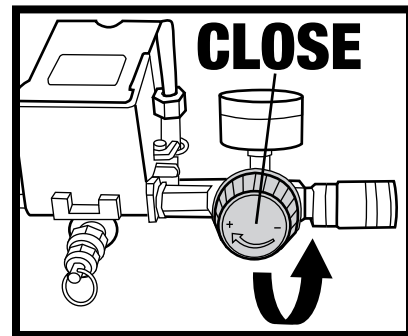

STEP 3

Attach hose and accessories (not provided).

Apply plumber's tape on all the threads to prevent air leakage.

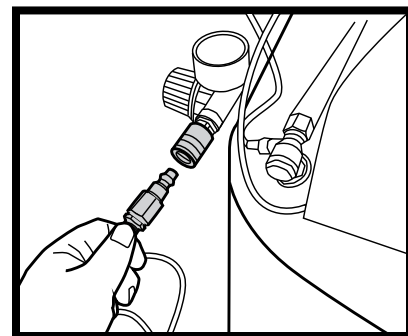

STEP 4

Close the tank drain valve, located on the bottom of the air tank.

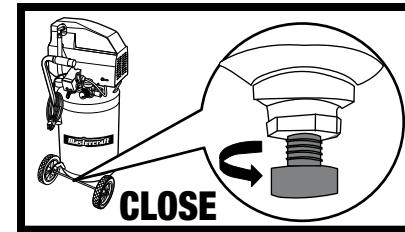

STEP 5

Plug in the power cord.
Caution: Connect the power cord only after break-in process has been completed, otherwise motor might get damaged (see *Breaking-in the pump*, page 14).

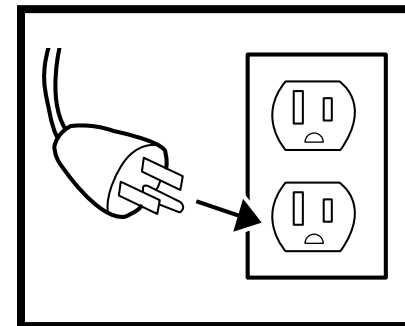

STEP 6

Set the pressure switch to the **ON** position. Turn the air pressure regulator knob clockwise until desired pressure is reached.

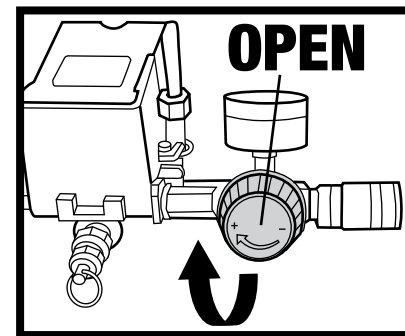

QUICK START GUIDE	
TECHNICAL SPECIFICATIONS	3
SAFETY GUIDELINES	4 – 6
KEY PARTS DIAGRAM	7
KEY PARTS LIST	8 – 9
INTENDED USE	10 – 11
ASSEMBLY	12 – 13
OPERATING INSTRUCTIONS	14 – 17
MAINTENANCE	18 – 19
TROUBLESHOOTING	20 – 21
EXPLODED VIEW	22
PARTS LIST	23
WARRANTY	24 – 25

PRODUCT NUMBER	058-8386-8
HORSEPOWER	3
TANK SIZE	11 U.S. GALLONS (41.6 L)
AIR DELIVERY (SCFM*) @ 40 PSI	6.2
AIR DELIVERY (SCFM*) @ 90 PSI	5.2
CUT-IN PRESSURE (PSI)	105
CUT-OUT PRESSURE (PSI)	135
PUMP DESIGN	OIL-LESS
MOTOR	INDUCTION
POWER	120 V, 60 Hz, 15 A
WEIGHT	66 lb 1 oz (30 kg)
POWER CORD	SJT 14 AWG / 72" (1.83 m)
EXTENSION CORD	SJT 12 AWG / MAXIMUM 30' (9.1 m)

* **SCFM:** *Standard Cubic Feet per Minute* (= The volumetric flow rate of a gas corrected to standardized conditions of temperature and pressure.)

This manual contains information that relates to **PROTECTING PERSONAL SAFETY** and **PREVENTING EQUIPMENT PROBLEMS**. It is very important to read this manual carefully and understand it thoroughly before using the product. The symbols listed below are used to indicate this information.



DANGER! Potential hazard that will result in serious injury or loss of life.



WARNING! Potential hazard that could result in serious injury or loss of life.

CAUTION! Potential hazard that may result in moderate injury or damage to equipment.





IMPORTANT! Installation, operation or maintenance information that is important but not hazard related.

Safety Advice









DANGER!

- 

RISK OF FIRE OR EXPLOSION. Do not spray a flammable or combustible liquid or paint near sparks, flames, pilot lights or in a confined area. The spray area must be well-ventilated. Keep compressor at least 20' (6 m) away from spray area. Do not carry and operate the compressor or any other electrical device near the spray area. Never smoke when spraying. Use a minimum of 25' (7.6 m) of hose to connect a spray gun to the compressor.
- 

RISK OF ELECTRIC SHOCK. Do not expose to rain. Store indoors. Hazardous voltage. Disconnect from power source before servicing. Compressor must be grounded. Do not use grounding adaptors.
- 

RISK OF BURSTING. Make sure the regulator is adjusted so that the compressor outlet pressure is set lower than the maximum operating pressure of the spray gun or tool. Before starting the compressor, pull the ring on the safety valve to make sure the valve moves freely (see diagram on page 17). Drain water from tank after each use. Do not weld or repair tank.

4.  **RISK OF PERSONAL INJURY.** Never spray compressed air or material at self or others.
5.  **RISK OF BURSTING.** Check the maximum pressure rating in the manual or identification label. The compressor outlet pressure must be regulated so that it does not exceed the maximum pressure rating. Relieve all pressure in the hose before removing or attaching accessories.
6.  **RISK OF BURSTING.** Do not adjust the pressure switch or safety valve for any reason. They have been preset at the factory for this compressor's maximum pressure. Tampering with the pressure switch or the safety valve may cause personal injury or property damage.
7.  **RISK OF BURNS.** The pump and the manifold generate high temperatures. In order to avoid burns or other injuries, do not touch the pump, the manifold or the transfer tube while the compressor is running. Allow the parts to cool down before handling or servicing. Keep children away from the compressor at all times.
8.  **RISK TO BREATHING.** Be certain to read all labels when you are spraying paints or toxic materials, and follow all safety instructions. Use a respirator mask if there is a chance of inhaling anything you are spraying. Also, NEVER directly inhale the air produced by a compressor.
9.  **RISK OF EYE INJURY.** Wear ANSI Z87.1 approved safety goggles when using an air compressor. Do not point any nozzle or sprayer toward a person or any part of the body. Serious injury may occur if the spray penetrates the skin.



WARNING!

1. Pull the pressure safety valve ring every day in order to ensure that the valve is functioning properly.
2. The compressor must be located in a well-ventilated area for cooling, and must be a minimum of 12" (31 cm) away from the nearest wall.
3. Protect the air hose and the power cord from damage and puncture. Inspect them for weak or worn spots every week, and replace them if necessary.
4. Always wear hearing protection when using an air compressor. Failure to do so may result in hearing loss.
5. Do not carry the compressor while it is running.

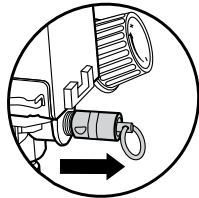

Mastercraft

AIR COMPRESSOR 11-GALLON (41.6 L) - 058-8386-8

6. Do not operate the compressor if it is not in a stable position.
7. Do not operate the compressor on a rooftop or an elevated position that could allow the unit to fall or be tipped over.
8. Always replace a damaged gauge before operating the unit again.

Extension cords

As the distance from the supply outlet increases, you must use a heavier gauge extension cord. Using extension cords with inadequately sized wire causes a serious drop in voltage, resulting in loss of power and possible product damage. Refer to the table here to determine the required minimum wire size.

Recommended Minimum Wire Gauge for Extension Cords* (120 V)

AMPERE RATING	CORD SIZE IN AWG (AMERICAN WIRE GAUGE)					
	Extension cord length in feet					
	25'	50'	75'	100'	150'	200'
0 - 5	16	16	16	14	12	12
5.1 - 8	16	16	14	12	10	--
8.1 - 12	14	14	12	10	--	--
12.1 - 15	12	12	10	10	--	--
15.1 - 20	10	10	10	--	--	--

* Based on limiting the line voltage drop to five volts at 150% of the rated amperes.

The smaller the gauge number of the wire, the greater the capacity of the cord. For example, a 14-gauge cord can carry a higher current than a 16-gauge cord. When using more than one extension cord to make up the total length, be sure each cord contains at least the minimum wire size required.

Guidelines for using extension cords

- If you are using an extension cord outdoors, be sure it is marked with the suffix "W-A" ("W" in Canada) to indicate it is acceptable for outdoor use.
- Ensure your extension cord is properly wired and in good electrical condition. Always replace a damaged extension cord or have it repaired by a qualified technician before using it.
- Protect your extension cords from sharp objects, excess heat and damp or wet areas.

AIR COMPRESSOR 11-GALLON (41.6 L) - 058-8386-8

Mastercraft

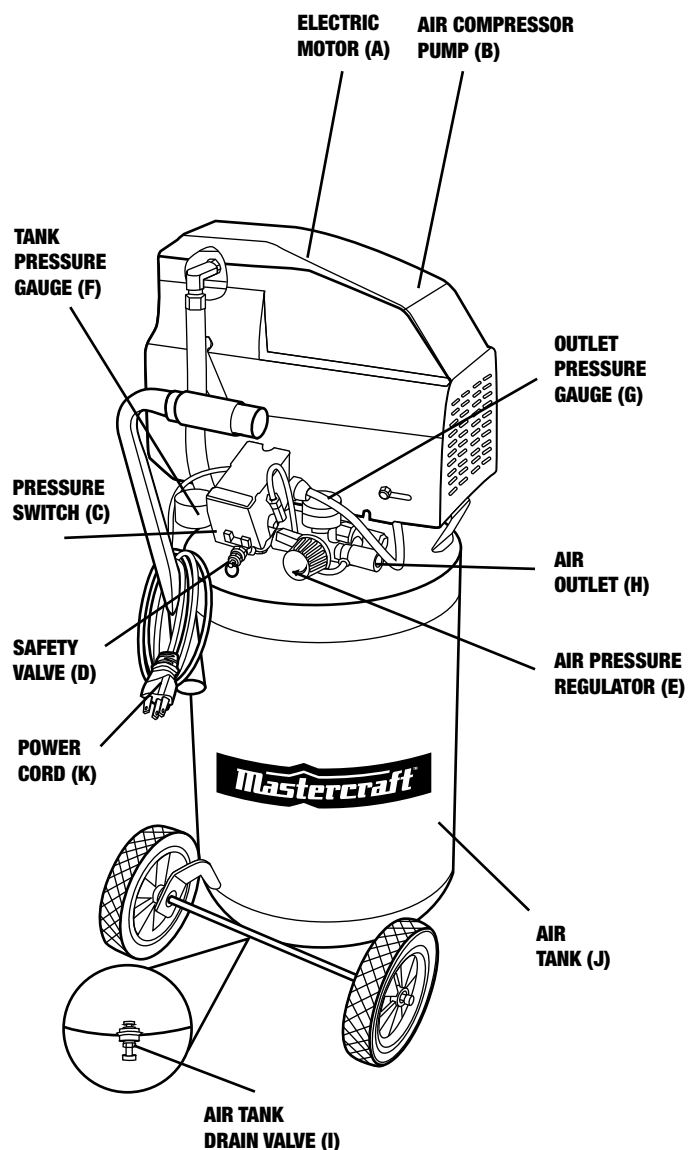
Mastercraft

AIR COMPRESSOR 11-GALLON (41.6 L) - 058-8386-8

- A. ELECTRIC MOTOR:** The motor is used to power the pump. It is equipped with a thermal overload protector. If the motor overheats for any reason, the thermal overload protector will shut it down in order to prevent the motor from being damaged.
- B. AIR COMPRESSOR PUMP:** The pump compresses the air and discharges it into the tank via the piston that moves up and down in the cylinder.
- C. PRESSURE SWITCH:** This switch turns the compressor on and off. It is operated manually and when it is in the ON position, it allows the motor to start if the pressure in the air tank is below the factory set cut-in pressure, and allows the motor to stop if the pressure in the air tank reaches the factory set cut-out pressure. Be sure to set this switch to the OFF position when the compressor is not being used and before unplugging the compressor.
- D. SAFETY VALVE:** This valve is used to prevent system failure by draining pressure from the system when it reaches a preset level if the pressure switch has not shut down the motor. It will pop open automatically, or it can be activated manually by pulling the ring on the valve.
- E. AIR PRESSURE REGULATOR:** The regulator is used to adjust the pressure inside the line to the tool that is being used. Turn the knob clockwise to increase the pressure and counter-clockwise to decrease the pressure.



WARNING! Do not exceed the tool's maximum working pressure.

- F. TANK PRESSURE GAUGE:** The gauge measures the pressure level of the air that is stored in the tank. It cannot be adjusted by the operator and it does not indicate the pressure inside the line.
- G. OUTLET PRESSURE GAUGE:** The gauge measures the regulated outlet pressure.
- H. AIR OUTLET:** The outlet is connected to the 1/4" (6.4 mm) NPT air hose.
- I. AIR TANK DRAIN VALVE:** The drain valve is used to remove moisture from the air tank after the compressor is shut off.



WARNING! Do not attempt to open the drain valve when there is more than 10 PSI of air pressure in the tank.

AIR COMPRESSOR 11-GALLON (41.6 L) - 058-8386-8

Mastercraft

J. **AIR TANK:** The tank is where the compressed air is stored.

K. **POWER CORD:** This compressor should be used on a nominal 120 V grounded circuit. Use a power cord that is equipped with a grounding plug. Verify that the compressor is plugged into an outlet that has the same configuration as the plug. Do not use an adapter with this compressor.

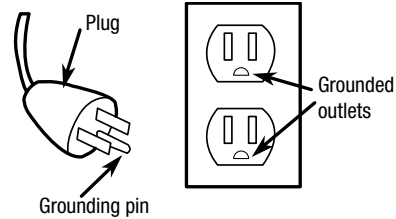

Before you start

This Mastercraft® Air Compressor is ideal for a wide-range of applications from, fastening to greasing and engine cleaning. The 11-gallon (41.6 L) design provides optimum pressure. It features oil-free use and a 3 HP universal motor for powerful, quiet operation.















The procedures described in this manual are solely for this 11-gallon (41.6 L) air compressor at a maximum of P=135 PSI. The device has been designed / constructed for household use only.



WARNING! This air compressor is not designed for continuous operation or unlimited, commercial operations and may be used in dry areas only. This air compressor is intended to be used in maximum 30-minute intervals and should rest for 30 minutes before being used again. **Do not exceed the maximum working time.**

Compatible compressor & air tool - proper usage & operation

Always ensure the use of appropriately matched air tools with your Mastercraft® Air Compressor. Be sure that the air compressor being used can supply the appropriate volume, pressure and delivery rate of air to the tool(s) without running continuously. Using tools or combinations of tools that, together or separately, require more than the air compressor can deliver will void the air compressor guarantee/warranty.

Tool Compatibility Chart			
Air Tool	Operates Tool Continuously	Operates Tool Intermittently	Not Recommended
 Inflation/Recreation (cleaning)	●		
 Finishing Nailer (16 gauge)	●		
 Framing Nailer	●		
 Flooring Nailer	●		
 Die Grinder/Angle Grinder/Air Ratchet	●		
 Cut-Off Tools		▼	
 DIY Paint Sprayers	●		
 Brad Nailers (18 gauge)	●		
 Brad Nailer/Staplers/Finish Nailers (16 & 18 gauge)	●		
 Roofing Nailer	●		
 Impact Wrenches	●		
 Drills, Hammer/Chisels, Shears	●		
 Sanders & Polishers		▼	
 Grease/Caulking Guns	●		

Assembly

1. Unpack the air compressor. Inspect the unit for damage. If the unit has been damaged, contact the retailer immediately.

THE CARTON SHOULD CONTAIN:

- Air compressor
- Owner's manual
- Air filter

2. Check the air compressor's identification label to ensure that you have purchased the intended model and that it has the required pressure rating for its intended use.

3. Positioning of the air compressor:

- a. Position the air compressor near an electrical outlet.
- b. The compressor must be at least 12" (31 cm) from any wall or obstruction, in a clean, well-ventilated area to ensure sufficient air flow and cooling.
- c. Place the air compressor on the floor or a hard, level surface. The air compressor must be level to ensure proper drainage of the moisture in the tank.

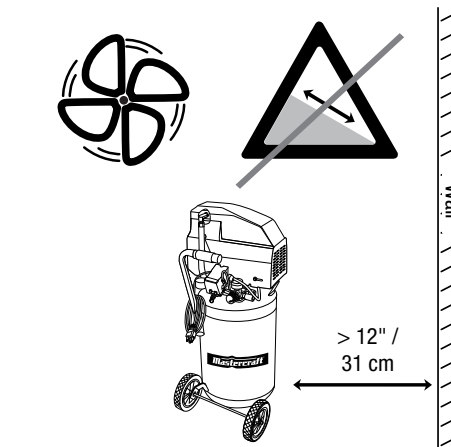

13

ASSEMBLY

4. Air filter assembly

- Screw the air filter onto the pump.

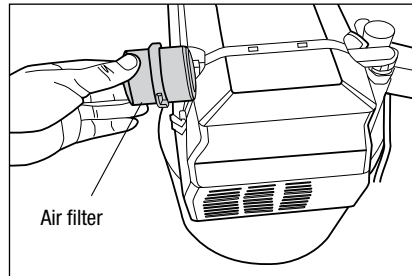

5. Connect air hose to compressor



NOTE: ¼" (6.4 mm) NPT air hose is required for connecting to the air compressor.

- Connect air hose (not provided) to the compressor's air outlet (H).

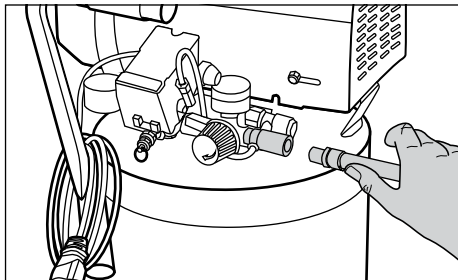

14

OPERATING INSTRUCTIONS

Breaking-in the pump

1. Set the pressure switch (C) to the OFF position.

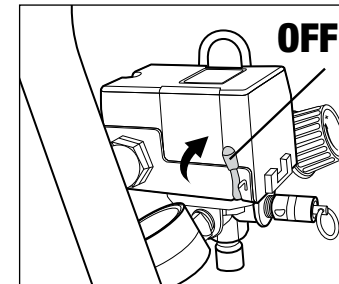

2. Open the tank drain valve (I) by turning it counter-clockwise to permit the air to escape and prevent air pressure build-up in the air tank during the break-in period.

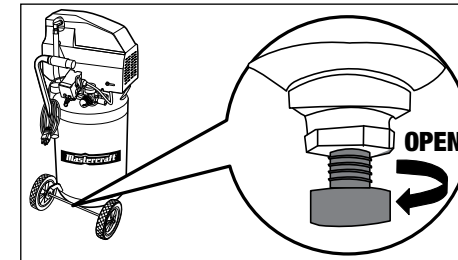

3. Turn the air pressure regulator knob (E) counter-clockwise until it stops.

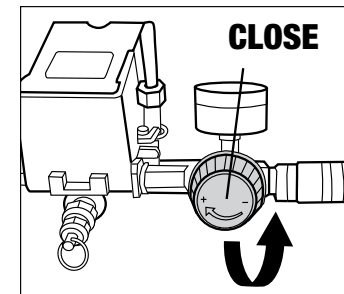

Mastercraft

AIR COMPRESSOR 11-GALLON (41.6 L) - 058-8386-8

AIR COMPRESSOR 11-GALLON (41.6 L) - 058-8386-8

Mastercraft

4. Plug in the power cord (K).



CAUTION! Use a dedicated circuit.

For best performance and reliable starting, the air compressor should be plugged into a dedicated circuit, as close as possible to the fuse box or circuit breaker.

The compressor will use the full capacity of a typical 14.5 A household circuit. If any other electrical devices are drawing from the compressor's circuit, the air compressor may fail to start. Low voltage or an overloaded circuit can result in sluggish starting that causes the motor overload protection system or circuit breaker to trip, especially in cold conditions.



NOTE: A circuit breaker is recommended. If the air compressor is connected to a circuit protected by a fuse, use dual element time delay fuses (type "T" only).

5. Set the pressure switch (C) to the **ON** position. The compressor will start. Run the compressor for 30 minutes. If it fails, turn it off immediately and call the toll-free helpline at: 1-800-689-9928. Please note that breaking-in the unit is only required prior to first use.

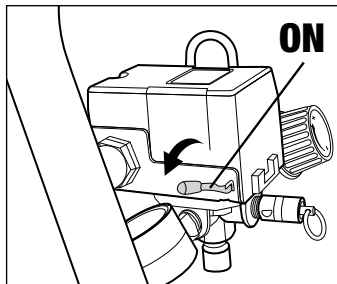

6. After 30 minutes, turn off the pressure switch (C).
7. Close the tank drain valve (I) by turning it clockwise.

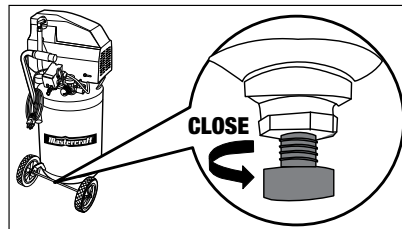

8. Set the pressure switch (C) to the **ON** position. The air receiver will fill to "cut-out" pressure and then the compressor's motor will stop. The compressor is now ready for use.

Mastercraft

AIR COMPRESSOR 11-GALLON (41.6 L) - 058-8386-8

Before each start-up

1. Set the pressure switch (C) to the **OFF** position.
2. Turn the air pressure regulator knob (E) counter-clockwise until it stops.
3. Attach hose and accessories.



WARNING! Risk of bursting. Too much air pressure causes a hazardous risk of bursting. Check the manufacturer's maximum pressure rating for air tools and accessories. The regulator outlet pressure must never exceed the maximum pressure rating.

How to start



WARNING! If the pump has been transported or turned upside down (even partially), allow the pump to sit in a normal, upright position for approximately 10 minutes before starting.

1. Close the tank drain valve (I).
2. Plug in the power cord (K).
3. Set the pressure switch (C) to the **ON** position and allow tank pressure to build. Motor will stop when tank pressure reaches "cut-out" pressure.
4. Turn the air pressure regulator knob (E) clockwise until desired pressure is reached.
5. The compressor is ready for use.



WARNING! High temperatures are generated by the electric motor and the pump. To prevent burns or other injuries, DO NOT touch the air compressor while it is running. Allow it to cool before handling or servicing. Keep children away from the air compressor at all times.

AIR COMPRESSOR 11-GALLON (41.6 L) - 058-8386-8

Mastercraft

How to shut down

1. Set the pressure switch (C) to the **OFF** position.
2. Unplug the power cord (K).
3. Reduce the pressure in the tank through the outlet hose. Pulling the safety valve ring (D) and keeping it open will also reduce the pressure in the tank.

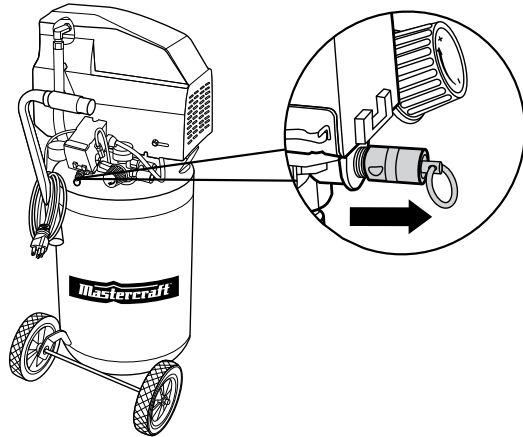

CAUTION! Escaping air and moisture can propel debris that may cause eye injury. Wear safety goggles when opening the drain valve.



WARNING! To avoid personal injury, always shut off and unplug the unit, and relieve all air pressure from the system before performing any service on the air compressor.



WARNING! Risk of unsafe operation. Unit cycles automatically when power is on. When performing maintenance, you may be exposed to voltage sources, compressed air or moving parts. Personal injuries can occur. Before performing any maintenance or repair, disconnect power source from the compressor and bleed off all air pressure.

ITEM	DESCRIPTION / REASON	SERVICE INTERVAL
Drain the tank	Through normal operation of your air compressor, condensation water will accumulate in the tank. To prevent corrosion of the tank from the inside, condensation must be drained at the end of every workday. Be sure to wear protective goggles. Relieve the air pressure in the system and open the drain valve on the bottom of the tank to drain. In cold conditions, it is especially important to drain the tank after each use to reduce the chance of problems resulting from the freezing of condensation water. NOTE: Refer to <i>To drain tank</i> , page 19.	Daily
Check the valve	Pull/activate the safety valve daily to ensure that it is operating properly and to clear the valve of any possible obstructions.	Daily
Clean the air filter	A dirty air filter will reduce air compressor performance and life. To avoid contaminating the pump, the filter should be cleaned frequently and replaced on a regular basis. Clean the foam filter by immersing it in warm, soapy water. Dry thoroughly after.	Weekly
Test for leaks	Check that all connections are tight. Small leaks in the tank, hoses, connections or transfer tubes will substantially reduce the air compressor and tool performance. Spray a small amount of soapy water around the area of suspected leaks with a spray bottle. If bubbles appear, repair, replace or re-seal the faulty component. Do not over tighten any connections.	Monthly
Storage	Before storing the air compressor, do the following: <ul style="list-style-type: none"> • Drain tank (see <i>Operating Instructions</i> paragraph in the <i>Maintenance</i> section of this manual for the correct procedure). • Use an air blow gun to clean all dust and debris from the compressor. • Disconnect and wind up the power cord. • Drain all moisture from the tank. • Pull the pressure safety valve to release all pressure from the tank. • Cover the entire unit to protect it from moisture and dust. • Store the air compressor in a clean and dry location. • In cold weather, store the compressor in a warm building when it is not in use. This will reduce problems related to starting the motor and the freezing of water condensation. 	Prior to storing

To check safety valve



WARNING! Risk of bursting. If the safety valve does not work properly, over-pressurization may occur, causing air tank rupture or an explosion.

- Before starting compressor, pull the ring on the safety valve (D) to make sure that the safety valve operates freely. If the valve is stuck or does not operate smoothly, contact a trained service technician.

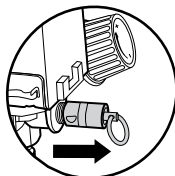

To drain tank



NOTE: Allow unit to cool before draining tank. Drain valve (I) becomes hot during operation.

1. Set the pressure switch (C) to the **OFF** position.
2. Unplug the power cord (K).
3. Turn air pressure regulator knob (E) counter-clockwise to set the outlet pressure to zero.
4. Pull and hold ring on safety valve (D), allowing air to bleed from the tank until air pressure is minimized.
5. Place suitable container under unit to catch water.
6. Slightly tilt unit and turn drain valve (I) counter-clockwise to open.



WARNING! Risk of bursting. Water will condense in the air tank. If not drained, water will corrode and weaken the air tank, causing a risk of air tank rupture.

7. After the water has been drained, close the drain valve (I) (clockwise). The air compressor can now be stored.

WARNING! If any of the following symptoms appears while operating the product, stop using the product immediately, or serious personal injury could result. Only an authorized service centre should perform repairs on this product.

Disconnect the electrical plug and disconnect any tools from air supply before attempting any adjustment.



NOTE: Troubleshooting problems may have similar causes and solutions.

PROBLEM	POSSIBLE CAUSES	SOLUTIONS	
The motor will not run or start.	The power cord is not plugged in.	Plug the power cord into a grounded outlet.	
	The pressure switch is in the OFF position.	Set the pressure switch to the ON position.	
	The extension cord is the wrong wire gauge or is too long.	Check <i>Technical Specifications</i> (page 3) for the proper wire gauge and cord length.	
	The motor's thermal overload protection has tripped.	Turn the air compressor off, unplug the power cord and wait until the motor has cooled down. Plug in the power cord only after the motor has cooled down, however wait at least 5 minutes to make sure the thermal overload protector has recovered.	
	A fuse has blown or a circuit breaker has been tripped.	Replace the fuse or reset the circuit breaker.	
		Verify that the fuse has the proper amperage.	
		Check for low voltage conditions.	
	The air tank pressure exceeds the preset pressure switch limit.	Disconnect any other electrical appliances from the circuit or operate the compressor on a dedicated circuit.	
		The air tank pressure exceeds the tank pressure drops below the cut-in pressure.	The motor will start automatically when the tank pressure drops below the cut-in pressure.
		The safety valve is stuck open.	Clean or replace the safety valve.
Electrical connections are loose.		Have the compressor serviced by a qualified technician.	
The motor, capacitor or safety valve is defective.	Have the compressor serviced by a qualified technician.		
The motor runs continuously when the pressure switch is in the ON position.	The pressure switch does not shut off the motor when the air compressor reaches the cut-out pressure and the safety valve activates.	Set the pressure switch to the OFF position. If the motor does not shut off, unplug the air compressor. If the pressure switch is defective, replace it.	
	The compressor's capacity is not enough.	Check the air requirements of the accessory that is being used. If it is higher than the SCFM (<i>Standard Cubic Feet per Minute</i> , page 3) and pressure supplied by the compressor, a larger capacity air compressor is needed. Most accessories are rated at 25% of actual SCFM while running continuously.	

PROBLEM	POSSIBLE CAUSES	SOLUTIONS
The regulator does not regulate the pressure.	The regulator or its internal parts are dirty or damaged.	Replace the regulator.
The pressure is low or there is not enough air.	There is a leak at one of the fittings.	Check the fittings with soapy water. Tighten or reseal leaking fittings (apply plumber's tape on threads). Do not overtighten.
	The tank drain valve is open.	Close the drain valve.
	The air intake is restricted.	Clean or replace the air filter element.
	Prolonged excessive use of air.	Decrease the amount of air used.
	There is a hole in the air hose.	Check the air hose and replace it if necessary.
	The tank leaks.	Replace the tank immediately. Do not attempt to repair it.
There is moisture in the discharge air.	The valve is leaking.	Check for worn parts and replace them if necessary.
	There is condensation in the air tank caused by a high level of atmospheric humidity or because the air compressor has not been running long enough.	Drain the air tank after each use. Drain the air tank more often in humid weather and use an air line filter.
The compressor overheats.	The ventilation is inadequate.	Relocate the compressor to an area with cool, dry and well-circulated air.
	Cooling surfaces are dirty.	Clean all cooling surfaces on the pump and the motor thoroughly.
	The valve is leaking.	Replace worn parts and reassemble using new Teflon tape.



SCAN & LEARN
Shop smarter on your smartphone
Scan barcode for more information on compressors and air tools.

NUMÉRISER ET APPRENEZ
Facilitez vos achats avec votre téléphone intelligent

Balayez le code à barres pour obtenir plus de renseignements sur les compresseurs et les outils pneumatiques.

Get the free app at/Obtenez l' application gratuite sur : canadiantire.ca/mobileapp



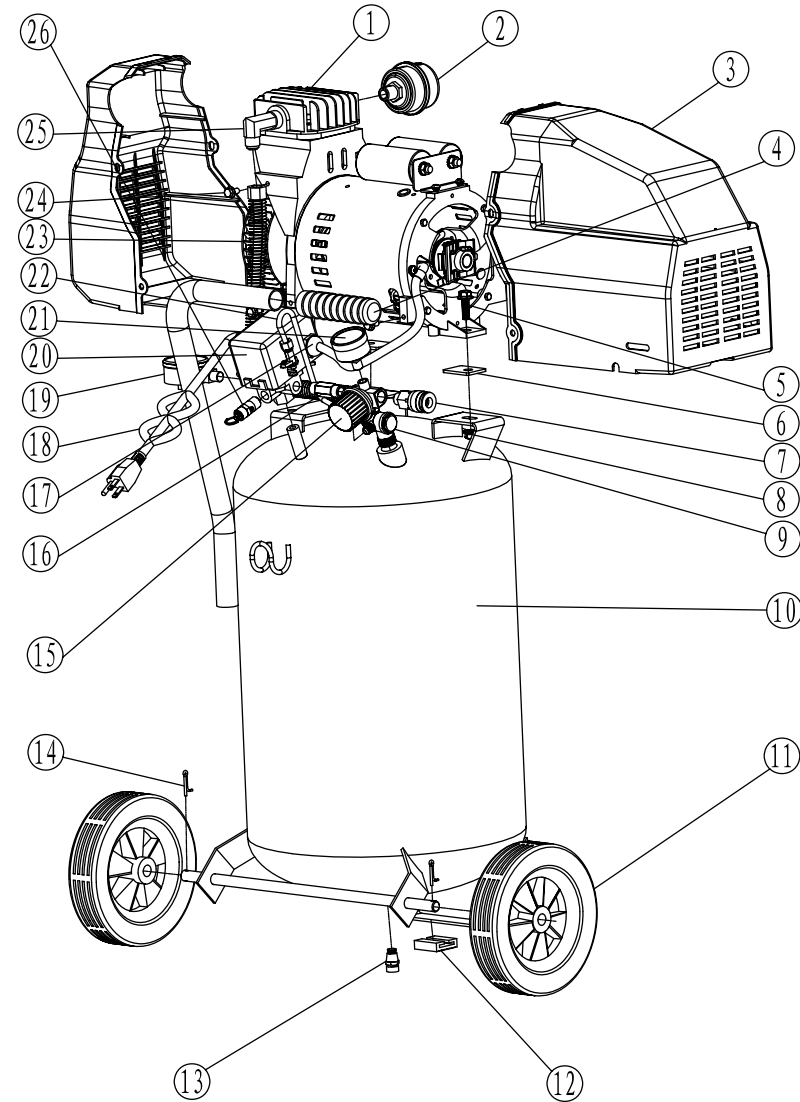

NO.	DESCRIPTION	QTY	NO.	DESCRIPTION	QTY
1	Pump and motor assembly	1	14	Cotter pin	2
2	Air filter	1	15	Regulator	1
3	Shroud front and rear	1	16	Adaptor fitting	1
4	Handle grip	1	17	Strain relief	2
5	Hex-bolt	3	18	Power cord	1
6	Rubber pad	3	19	Tank pressure gauge	1
7	Quick coupler	1	20	Pressure switch	1
8	Hex-nut	3	21	Air pressure gauge	1
9	Check valve	1	22	Bleeding tube	1
10	Air tank	1	23	Transfer tube	1
11	Wheel	2	24	Hex-bolt	6
12	Rubber foot	2	25	Right elbow	1
13	Drain valve	1	26	Safety valve	1

If any parts are missing or damaged, or if you have any questions, please call our toll-free helpline at 1-800-689-9928.



This Mastercraft® product is guaranteed **for a period of three years from the date of original retail purchase** against defects in materials and workmanship.

Subject to the conditions and limitations described below, this product, if returned to us with proof of purchase within the stated warranty period and if covered under this warranty, will be repaired or replaced (with the same model, or one of equal value or specification), at our option. We will bear the cost of any repair or replacement and any costs of labour relating thereto.

This warranty is subject to the following conditions and limitations:

- A. A bill of sale verifying the purchase and purchase date must be provided;
- B. This warranty will not apply to any product or part thereof which is worn or broken or which has become inoperative due to abuse, misuse, accidental damage, neglect or lack of proper installation, operation or maintenance (*as outlined in the applicable owner's manual or operating instructions*) or which is being used for industrial, professional, commercial or rental purposes;
- C. This warranty will not apply to normal wear and tear or to expendable parts or accessories that may be supplied with the product which are expected to become inoperative or unusable after a reasonable period of use;
- D. This warranty will not apply to routine maintenance and consumable items such as, but not limited to, fuel, lubricants, vacuum bags, blades, belts, sandpaper, bits, fluids, tune-ups or adjustments;
- E. This warranty will not apply where damage is caused by repairs made or attempted by others (*i.e. persons not authorized by the manufacturer*);
- F. This warranty will not apply to any product that was sold to the original purchaser as a reconditioned or refurbished product (*unless otherwise specified in writing*);
- G. This warranty will not apply to any product or part thereof if any part from another manufacturer is installed therein or any repairs or alterations have been made or attempted by unauthorized persons;
- H. This warranty will not apply to normal deterioration of the exterior finish, such as, but not limited to, scratches, dents, paint chips, or to any corrosion or discolouring by heat, abrasive and chemical cleaners; and
- I. This warranty will not apply to component parts sold by and identified as the product of another company, which shall be covered under the product manufacturer's warranty, if any.

Additional Limitations

This warranty applies only to the original purchaser and may not be transferred. Neither the retailer nor the manufacturer shall be liable for any other expense, loss or damage, including, without limitation, any indirect, incidental, consequential or exemplary damages arising in connection with the sale, use or inability to use this product.

Notice to Consumer

This warranty gives you specific legal rights, and you may have other rights, which may vary from province to province. The provisions contained in this warranty are not intended to limit, modify, take away from, disclaim or exclude any statutory warranties set forth in any applicable provincial or federal legislation. Imported by Mastercraft Canada Toronto, Canada M4S 2B8.



AIR COMPRESSOR 11-GALLON (41.6 L) - 058-8386-8

AIR COMPRESSOR 11-GALLON (41.6 L) - 058-8386-8

