



## Operating Manual

### Ultrasonic proximity switch with two switching outputs and IO-Link

- lpc+15/CFE      lpc+15/WK/CFE
- lpc+25/CFE      lpc+25/WK/CFE
- lpc+35/CFE      lpc+35/WK/CFE
- lpc+100/CFE     lpc+100/WK/CFE

**Product description**  
The lpc+ sensor offers a non-contact measurement of the distance to an object which must be positioned within the sensor's detection zone. The switching output is set conditional upon the adjusted switching distance. Via the Teach-in procedure, the distance and operating mode can be adjusted. Four LEDs indicate the state of the switching outputs.

**IO-Link**  
The lpc+ sensor is IO-Link-capable in accordance with IO-Link specification V1.1 and supports Smart Sensor Profile like Digital Measuring Sensor. The sensor can be monitored and parameterized via IO-Link.

**Safety instructions**  
■ Read the operating manual prior to start-up.

- Connection, installation and adjustments may only be carried out by qualified staff.
- No safety component in accordance with the EU Machine Directive, use in the area of personal and machine protection not permitted

**Proper Use**  
lpc+ ultrasonic sensors are used for non-contact detection of objects.

**Installation**  
→ Mount the sensor at the place of fitting.  
→ Connect a connection cable to the M12 device plug, see Fig. 1.

**Start-up**  
→ Connect the power supply.  
→ Set the parameters of the sensor by using the Teach-in procedure, see Diagram 1.

	microsonic notation	IO-Link notation	IO-Link Smart Sensor Profile	colour
1	+U <sub>B</sub>	L+		brown
2	F1	Q	SSC2	white
3	-U <sub>B</sub>	L-		blue
4	F2	C/Q	SSC1	black
5	Com	NC		grey

Fig. 1: Pin assignment with view onto sensor plug, IO-Link notation and colour coding of the microsonic connection cables

- Factory setting**
- Switching point operation
  - Switching output on NOC
  - Switching distances at operating range and half operating range
  - Input Com set to »Teach-in + sync«
  - Filter at F01
  - Filter strength at P00
- Operating modes**  
Three operating modes are available for the switching output:
- **Operation with one switching point**  
The switching output is set when the object falls below the set switching point.
  - **Window mode**  
The switching output is set when the object is outside the window limits.

- **Two-way reflective barrier**  
The switching output is set when the object is between sensor and fixed reflector.

**Synchronisation**  
If the assembly distance of multiple sensors falls below the values shown in Fig. 2, the internal synchronisation should be used (»Teach-in + sync« must be switched on, see Diagram 1). For this purpose set the switching outputs of all sensors in accordance with Diagram 1. Finally interconnect each pin 5 of the sensors to be synchronised.

	↕	↔
lpc+15...	≥0.25 m	≥1.30 m
lpc+25...	≥0.35 m	≥2.50 m
lpc+35...	≥0.40 m	≥2.50 m
lpc+100...	≥0.70 m	≥4.00 m

Fig. 2: Assembly distances.

**Maintenance**  
microsonic sensors are maintenance-free. In case of excess caked-on dirt we recommend cleaning the white sensor surface.

- Notes**
- Pin 5 (Com) of the sensor may only be connected during Teach-in procedures or for synchronisation.
  - The sensors of the lpc+ family have a blind zone, within which a distance measurement is not possible.
  - The lpc+ sensors are equipped with an internal temperature compensation. Due to the sensors self heating, the temperature compensation reaches its optimal working point after approx. 120 seconds of operation.
  - The lpc+ sensors have two push-pull switching outputs.
  - In the normal operating mode, an illuminated yellow LED signals that the related switching output is set.
  - In IO-Link mode, the green LED D2 flashes.
  - If a Teach-in process is not completed, all changes are deleted after approx. 4 minutes.
  - In the »Two-way reflective barrier« operating mode, the object has to be within the range of 0 to 92 % of the set distance.

## Diagram 1: Set sensor parameters via Teach-in procedure

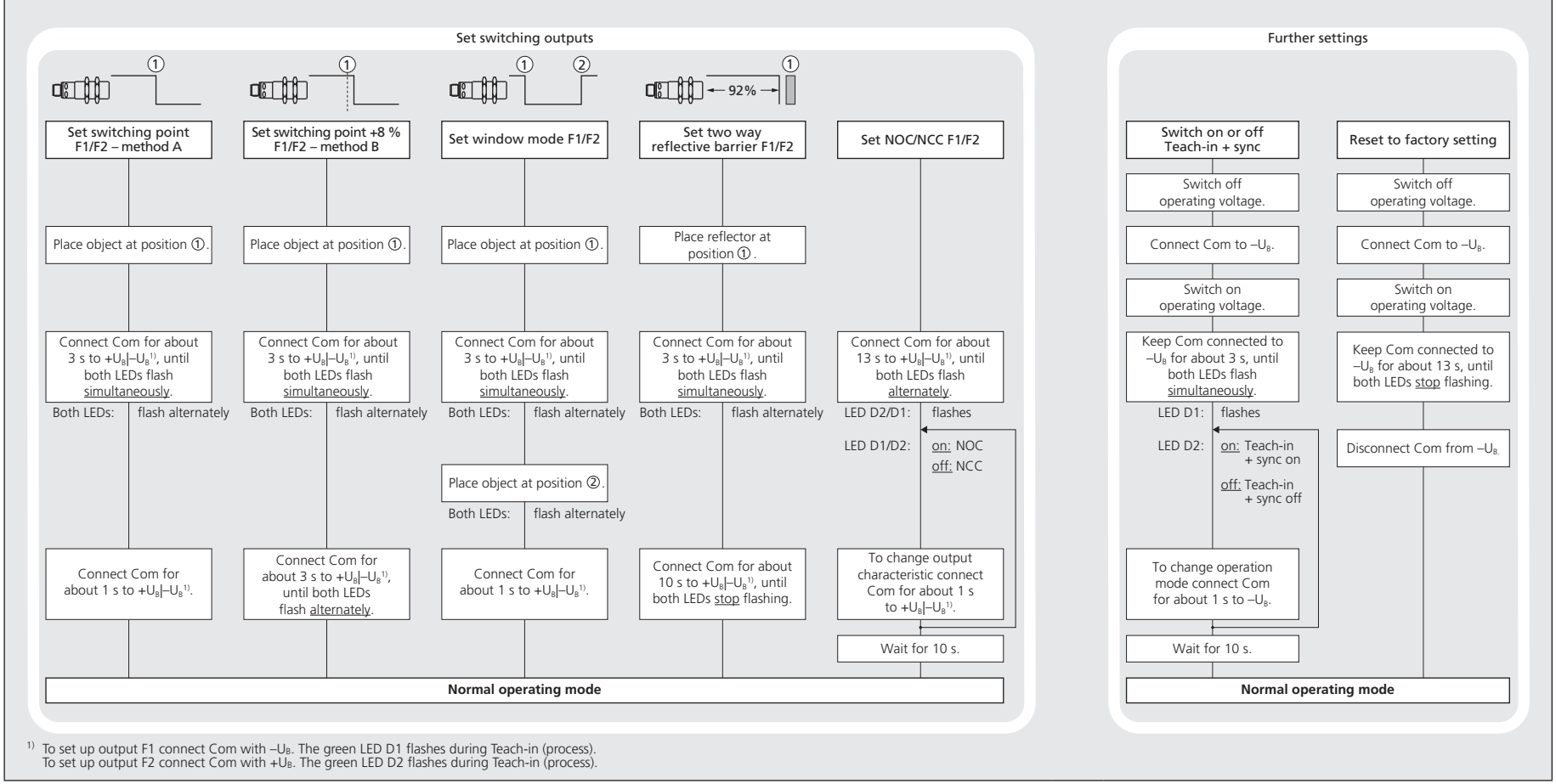

<sup>1)</sup> To set up output F1 connect Com with -U<sub>B</sub>. The green LED D1 flashes during Teach-in (process). To set up output F2 connect Com with +U<sub>B</sub>. The green LED D2 flashes during Teach-in (process).

**Technical data**

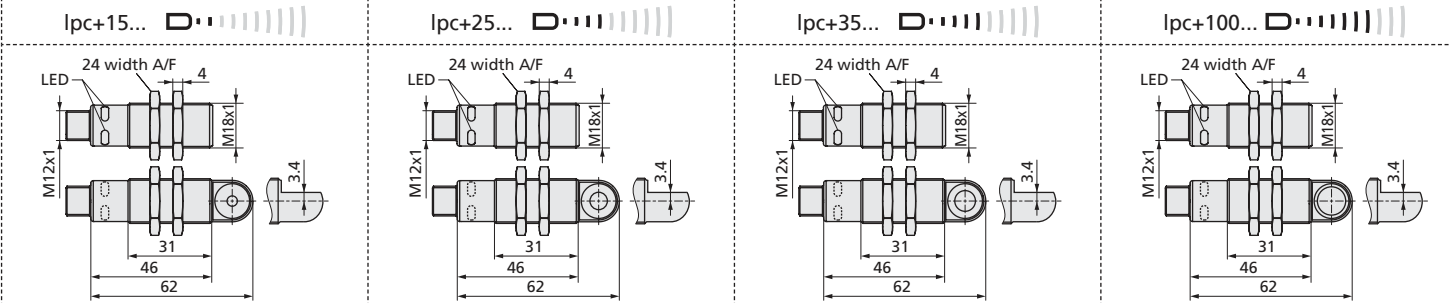
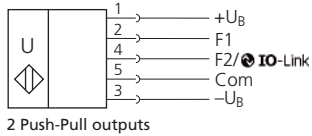

<b>blind zone</b>	0 to 20 mm	0 to 30 mm	0 to 65 mm	0 to 120 mm
<b>operating range</b>	150 mm	250 mm	350 mm	1,000 mm
<b>maximum range</b>	250 mm	350 mm	600 mm	1,300 mm
<b>angle of beam spread</b>	see detection zone	see detection zone	see detection zone	see detection zone
<b>transducer frequency</b>	380 kHz	320 kHz	400 kHz	200 kHz
<b>resolution</b>	0.1 mm	0.1 mm	0.1 mm	0.1 mm
<b>reproducibility</b>	±0.15 %	±0.15 %	±0.15 %	±0.15 %

**detection zones**  
for different objects:  
The dark grey areas represent the zone where it is easy to recognise the normal reflector (round bar). This indicates the typical operating range of the sensors. The light grey areas represent the zone where a very large reflector – for instance a plate – can still be recognised. The requirement here is for an optimum alignment to the sensor. It is not possible to evaluate ultrasonic reflections outside this area.

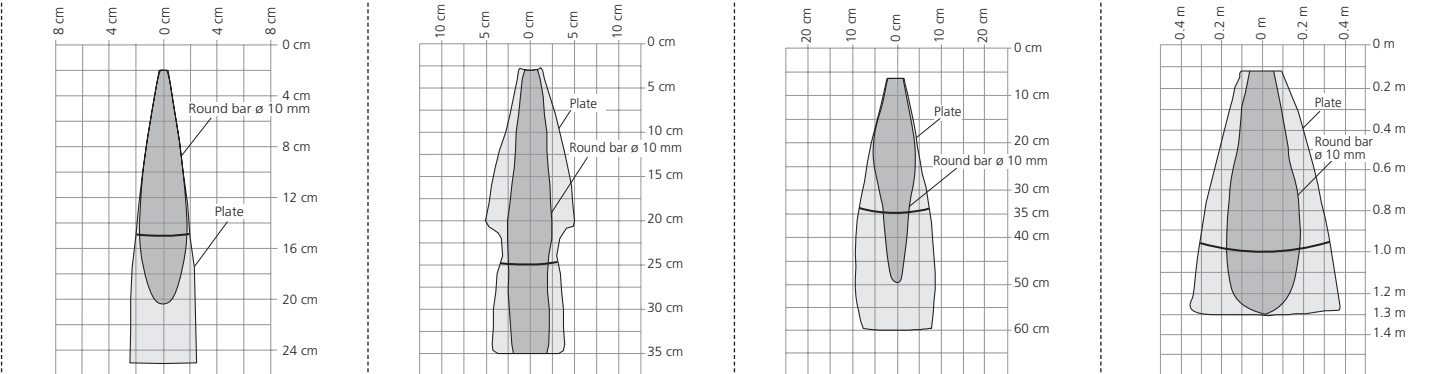

<b>accuracy</b>	±1 % (temperature drift internally compensated)	±1 % (temperature drift internally compensated)	±1 % (temperature drift internally compensated)	±1 % (temperature drift internally compensated)
<b>operating voltage <math>U_B</math></b>	10 to 30 V DC, reverse polarity protection (Class 2)	10 to 30 V DC, reverse polarity protection (Class 2)	10 to 30 V DC, reverse polarity protection (Class 2)	10 to 30 V DC, reverse polarity protection (Class 2)
<b>voltage ripple</b>	±10 %	±10 %	±10 %	±10 %
<b>no-load current consumption</b>	<50 mA	<50 mA	<50 mA	<50 mA
<b>housing</b>	brass sleeve, nickel-plated, plastic parts: PBT; ultrasonic transducer: polyurethane foam, epoxy resin with glass content	brass sleeve, nickel-plated, plastic parts: PBT; ultrasonic transducer: polyurethane foam, epoxy resin with glass content	brass sleeve, nickel-plated, plastic parts: PBT; ultrasonic transducer: polyurethane foam, epoxy resin with glass content	brass sleeve, nickel-plated, plastic parts: PBT; ultrasonic transducer: polyurethane foam, epoxy resin with glass content
<b>max. tightening torque of nuts</b>	15 Nm	15 Nm	15 Nm	15 Nm
<b>class of protection per EN 60529</b>	IP 67	IP 67	IP 67	IP 67
<b>norm conformity</b>	EN 60947-5-2	EN 60947-5-2	EN 60947-5-2	EN 60947-5-2
<b>type of connection</b>	5-pin M12 circular plug	5-pin M12 circular plug	5-pin M12 circular plug	5-pin M12 circular plug
<b>controls</b>	Teach-in via pin 5 (Com)	Teach-in via pin 5 (Com)	Teach-in via pin 5 (Com)	Teach-in via pin 5 (Com)
<b>scope for settings</b>	Teach-in, LinkControl, IO-Link	Teach-in, LinkControl, IO-Link	Teach-in, LinkControl, IO-Link	Teach-in, LinkControl, IO-Link
<b>IO-Link</b>	V1.1	V1.1	V1.1	V1.1
<b>indicators</b>	2 x LED green, 2 x LED yellow	2 x LED green, 2 x LED yellow	2 x LED green, 2 x LED yellow	2 x LED green, 2 x LED yellow
<b>synchronisation</b>	internal synchronisation up to 10 sensors	internal synchronisation up to 10 sensors	internal synchronisation up to 10 sensors	internal synchronisation up to 10 sensors
<b>operating temperature</b>	-25 to +70 °C	-25 to +70 °C	-25 to +70 °C	-25 to +70 °C
<b>storage temperature</b>	-40 to +85 °C	-40 to +85 °C	-40 to +85 °C	-40 to +85 °C
<b>switching hysteresis<sup>2)</sup></b>	2 mm	3 mm	5 mm	20 mm
<b>switching frequency<sup>2)</sup></b>	25 Hz	25 Hz	12 Hz	10 Hz
<b>response time<sup>3)</sup></b>	32 ms	32 ms	64 ms	80 ms
<b>time delay before availability</b>	<300 ms	<300 ms	<300 ms	<300 ms
<b>switching outputs</b>	2 x Push-Pull, $U_B-3 V, -U_B+3 V, I_{max} = 2 \times 100 mA$ switchable NOC/NCC, short-circuit-proof	2 x Push-Pull, $U_B-3 V, -U_B+3 V, I_{max} = 2 \times 100 mA$ switchable NOC/NCC, short-circuit-proof	2 x Push-Pull, $U_B-3 V, -U_B+3 V, I_{max} = 2 \times 100 mA$ switchable NOC/NCC, short-circuit-proof	2 x Push-Pull, $U_B-3 V, -U_B+3 V, I_{max} = 2 \times 100 mA$ switchable NOC/NCC, short-circuit-proof
<b>order no. directly radiating</b>	<b>lpc+15/CF</b>	<b>lpc+25/CF</b>	<b>lpc+35/CF</b>	<b>lpc+100/CF</b>
<b>weight</b>	35 g	35 g	35 g	35 g
<b>order no. angular head</b>	<b>lpc+15/WK/CF</b>	<b>lpc+25/WK/CF</b>	<b>lpc+35/WK/CF</b>	<b>lpc+100/WK/CF</b>
<b>weight</b>	40 g	40 g	40 g	40 g

<sup>2)</sup> Can be programmed via LinkControl and IO-Link.

<sup>3)</sup> With LinkControl an IO-Link, the selected filter setting influences the switching frequency and response time.

■ In the »Set switching point – method A« Teach-in procedure the actual distance to the object is taught to the sensor as the switching point. If the object moves towards the sensor (e.g. with level control) then the taught distance is the level at which the sensor has to switch the output.

■ If the object to be scanned moves into the detection area from the side, the »Set switching point +8 % – method B« Teach-in procedure should be used. In this way the switching distance is set 8 % further than the actual measured distance to the object. This ensures a reliable switching behavior even if the height of the objects varies slightly, see Fig. 3.

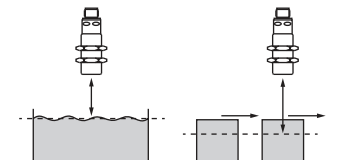

Fig. 3: Setting the switching point for different directions of movement of the object

- The sensor can be reset to its factory setting (see »Further settings«).
- The lpc+ sensor can be blocked against changes in the sensor via function »Switch on or off Teach-in + sync«, see Diagram 1.
- Using the LinkControl adapter (optional accessory) and the LinkControl software for Windows®, all Teach-in and additional sensor parameter settings can be optionally undertaken.
- The latest IODD file and informations about start-up and configuration of lpc+ sensors with IO-Link, you will find online at [www.microsonic.de/en/lpc+](http://www.microsonic.de/en/lpc+).



**UL LISTED** Enclosure Type 1  
For use only in industrial machinery NFPA 79 applications. The proximity switches shall be used with a Listed (CYJ/7) cable/connector assembly rated minimum 32 Vdc, minimum 290 mA, in the final installation.

