

MPPT

20A CONTROLLER

Model: L03DZMPPT20A-1



SUPPORT

If you are experiencing technical problems and cannot find a solution in this manual, please contact ECO-WORTHY for further assistance.



· Call: 1-866-939-8222 (US&CA)
+49 6175 6514 999 (DE)
+44 7553 406988 (UK)

· Web: www.eco-worthy.com/
· E-mail: customer.service@eco-worthy.com

Contents

I . Basic Information	1
II . Product Features	1
III. Charging Stages	2
IV. Packing List	2
V .Product Overview	3
VI.Installation Steps	3
VII.Usage Description	4
VIII.Setting Description	8
IX. Technical Parameters	13
X .APP Usage	15
XI.Troubleshooting and Maintenance	15
XII.Technical Support	17

I . Basic Information

This controller is designed specifically for solar power systems. It uses intelligent algorithms to dynamically adjust the working point of the solar panel, maximizing the energy captured from the solar panel for battery charging. It also prevents the battery from overcharging by the solar panel and over-discharging by the load.

II . Product Features:

1. Automatically detects and identifies 12V/24V GEL/SLA/FLD battery system voltages.

2. Uses MPPT algorithm to automatically find and lock the maximum power point of the solar panel, achieving an efficient tracking efficiency $\geq 98\%$ and peak conversion efficiency $\geq 98\%$.

3. External temperature sensor interface allows effective monitoring of battery electrode temperature when connected with a compatible sensor.

4. Supports GEL/SLA/FLD/LFP batteries, and parameters can be customized via APP.

5. Equipped with a 46*27mm high-definition LCD screen to display working status and fault information in real-time.

6. Can activate and charge lithium batteries in over-discharge protection mode, restoring them to usable condition.

7. Features multiple protection functions, including overcharge, over-discharge, and short-circuit protection, effectively extending battery life.

8. Built-in low-power Bluetooth module enables app-based control, parameter adjustment, and real-time status monitoring.

III. Charging Stages:

1. Bulk Charging Stage: The MPPT controller dynamically adjusts the voltage and current of the solar panel to operate at its maximum power point, providing the maximum energy input to the battery. The battery charging will typically enter the bulk charging stage until the battery reaches the bulk charge voltage, at which point it automatically exits this stage.

2. Balancing Charge Stage: This stage is a maintenance charging phase for lead-acid batteries, effectively extending the overall life of the battery pack. To prevent battery overheating and excessive gas evolution, bulk and balancing charging will not continuously occur in a complete charging cycle. The lead-acid battery will automatically enter the balancing charging stage during the first charge of each month, ending when the balancing charging time is over or the battery voltage equals the balancing charging voltage and the current is below the threshold, after which it enters the float charging stage.

3. Float Charging Stage: After the bulk or balancing charging stage is complete, the controller automatically enters the float charging stage, charging the battery with a small current.

IV. Packing List

- 1 x Controller
- 1 x 1.5M Temperature Sensor
- 5 x M4*30mm Phillips flat head self-tapping screws
- 5 x M6*30 mm Expansion Tube
- 1 x Manual

V . Product Overview



VI. Installation Steps

1. Determine the installation location of the product and mark the screw positions on a vertical surface.

Note: Ensure there is sufficient space above and below the controller for cable installation.

2. Drill holes at the marked positions with a 6mm diameter and a depth of approximately 30mm. Clean the holes thoroughly to remove any debris.

Note: The drilling depth should be greater than the length of the expansion tube to ensure that the expansion tube can be fully inserted into the wall.

3. Insert the M6*30 expansion tubes into the holes and hammer them into the wall until they are flush with the surface.

Note: Do not use excessive force to avoid damaging the tubes.

4. Insert the M4*30 Phillips pan-head self-tapping screws through the installation holes of the product and screw them into the expansion tubes from the front.

5. Check that the solar panel and battery are in good condition, then connect the wires in the order of battery first and then solar panel. The controller screen should light up.

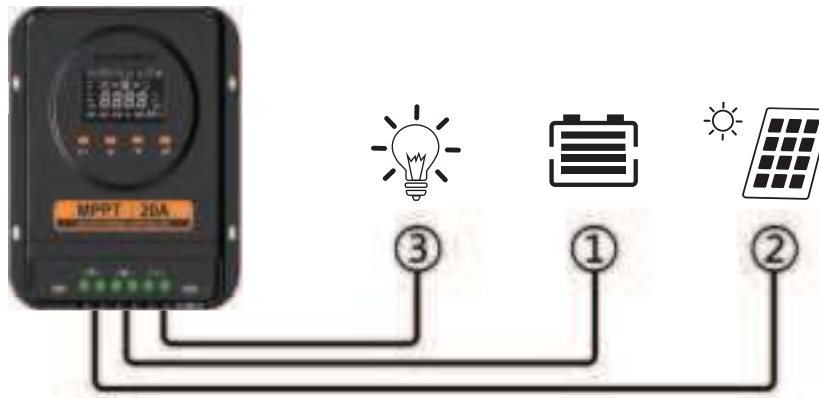
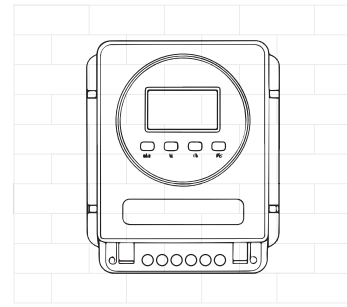
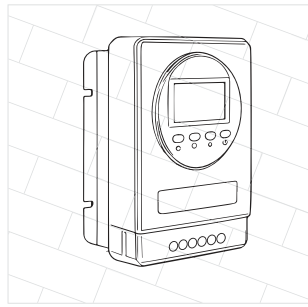
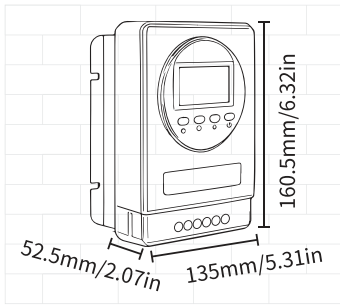



VII. Usage Description

1. Product Introduction

The controller is equipped with an LCD screen and four buttons for operation and settings.

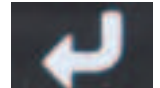

	Setting/Load Switch	Single click: Enter/exit the settings menu. Double click: In manual load mode, turn the load on/off.
	Up Switch Button	Single click: Scroll up to view/set menu.
	Down Switch Button	Single click: Scroll down to view/set menu.
	Confirm Button	Long press for 2S: Enter/save and exit the parameter settings.



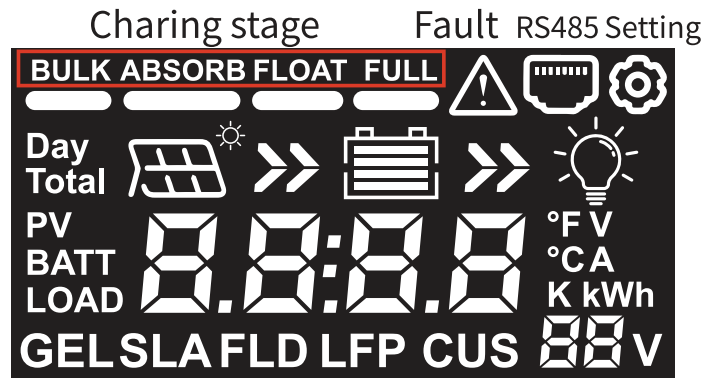

2. Icon Indicator









Indicator	Description
BULK Indicator	Battery in bulk charging stage
ABSORB Indicator	Battery in balancing charging stage
FLOAT Indicator	Battery in float charging stage
FULL Indicator	Battery is fully charged
No Charging Stage Indicator	Battery is not charging
Abnormal Indicator	Flashes when the controller detects an abnormality

RS485 Indicator	Indicates connection of BLUETOOTH AND WIFI MODULE 2.0 (Not included)
Setting Indicator	Lights up when entering the settings menu
Day Indicator	Displays the daily total value of PV power generation in the numeric display area
Total Indicator	Displays the historical total value of PV power generation in the numeric display area

3.Viewing Menu Interface

Viewing Menu	Display Content	Display
Page-1	Homepage	
Page-2	PV Voltage	
Page-3	Charging Power	
Page-4	Daily PV Power Generation	
Page-5	Historical PV Power Generation	

Page-6	Battery Charging Current	
Page-7	Battery Voltage	
Page-8	Battery Discharge Current/Load Current	
Page-9	Load Power	
Page-10	Load Working Mode	
Page-11	External Temperature Sensor Temperature	

4. Setting Menu Interface

Click the "Setting/Load Switch " to enter the settings menu. Use the Up/Down Switch Buttons to browse through the settings parameters. To modify a parameter, long press the Confirm Button for 2S until the parameter flashes, then use the Up/Down Switch Buttons to change the value. Save the settings by long pressing the Confirm Button again for 2S until the parameter lights up constantly, after which the system will automatically exit the parameter settings. To exit without making changes, simply click the "Setting/Load Switch " or wait for 10S of inactivity, and the system will automatically return to the viewing menu.

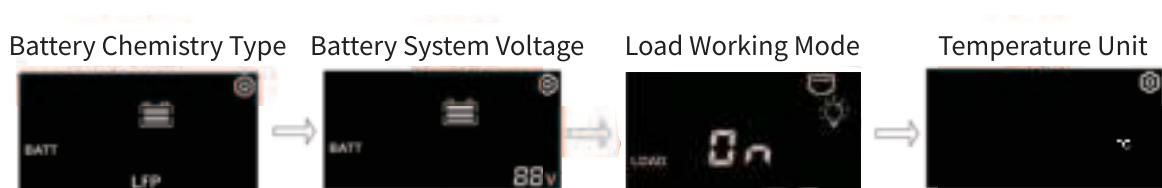

Note: Other parameter settings can be achieved via the APP.

VIII. Setting Description

1. Battery Chemistry Type Settings:

Default initial setting is Lithium Iron Phosphate (LFP). Four battery types can be set directly on the product. Custom battery types (CUS) require APP settings.

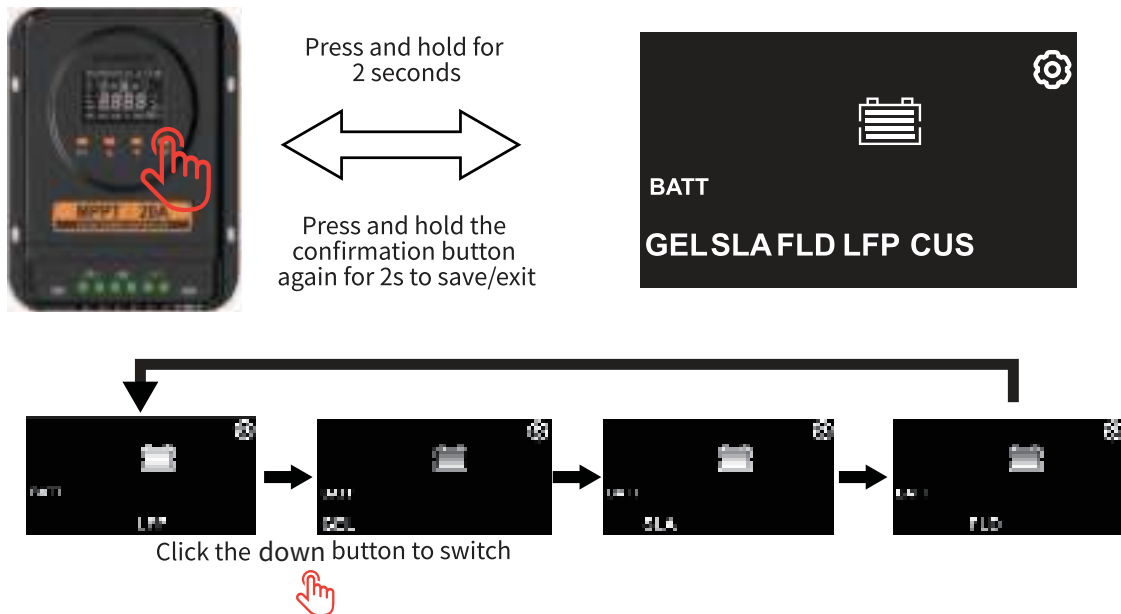

2. Battery System Voltage Settings:

Follows the battery type and remembers the voltage setting corresponding to the selected battery type. For LFP/CUS batteries, the default initial setting is 12V system voltage. For GEL/SLA/FLD, the default is automatic battery system identification (AU).

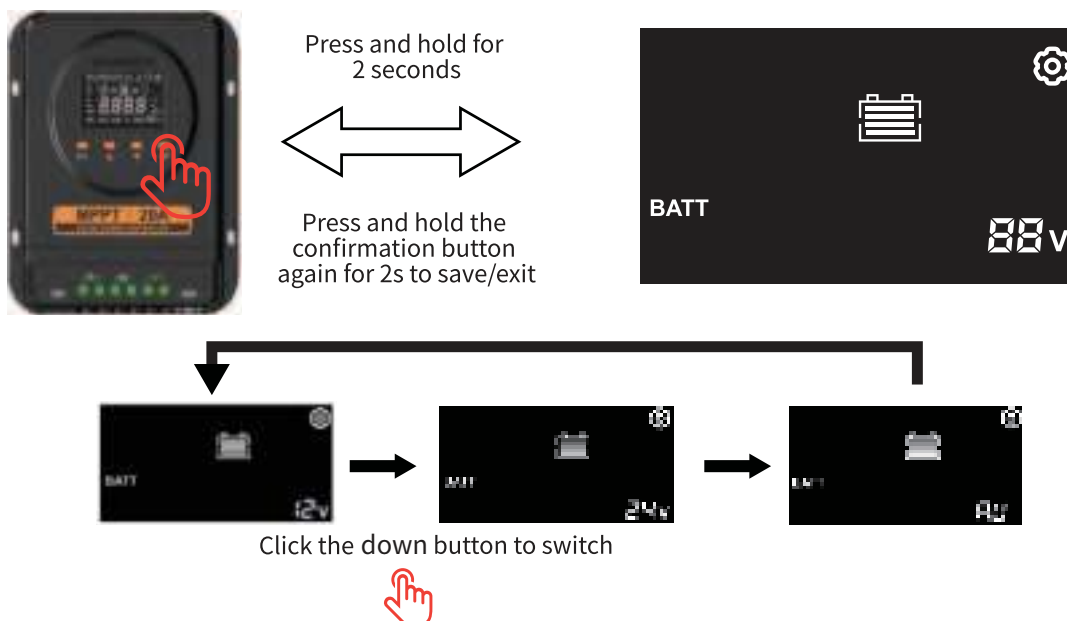

3. Load Working Mode Settings

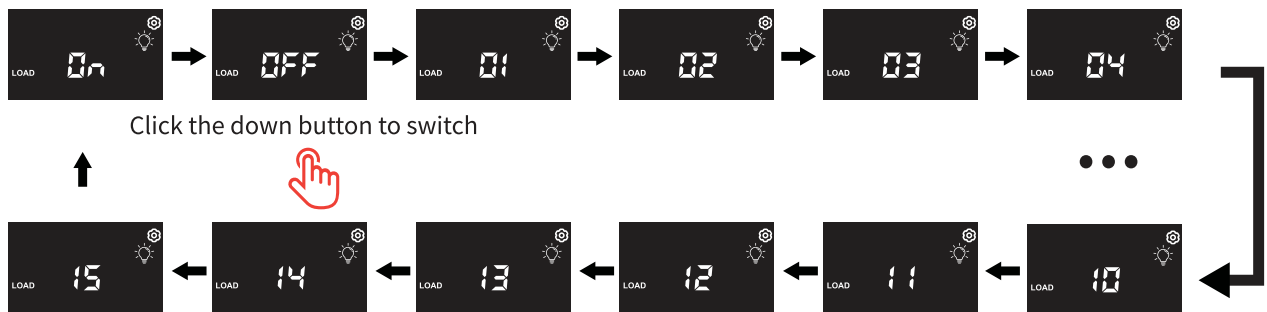
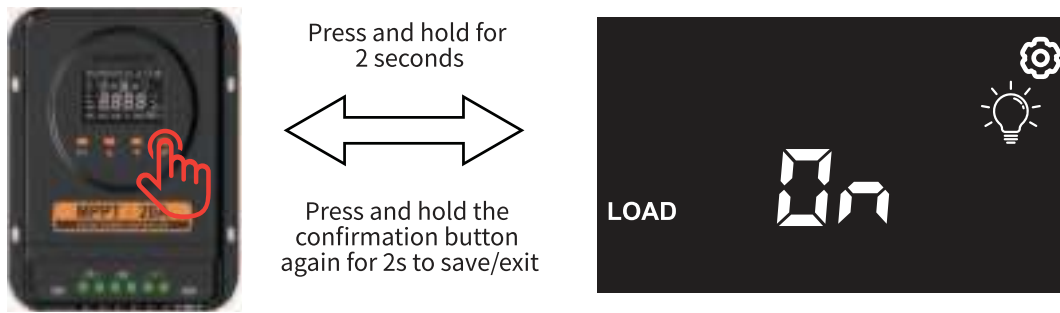

Setting	Mode	Description
On	Manual Mode-On	In this mode, users can turn the load on/off at any time by double-clicking the Confirm Button.
OFF	Manual Mode-Off	
0	Pure Light Control	The controller turns on the load when the PV voltage is lower than the battery voltage and turns it off when the PV voltage is higher.
1-15	Fixed Time Light Control Mode	When the PV voltage is lower than the battery voltage, the load will work until a set time point, after which the load will automatically turn off.

4. Display Temperature Unit Switch:



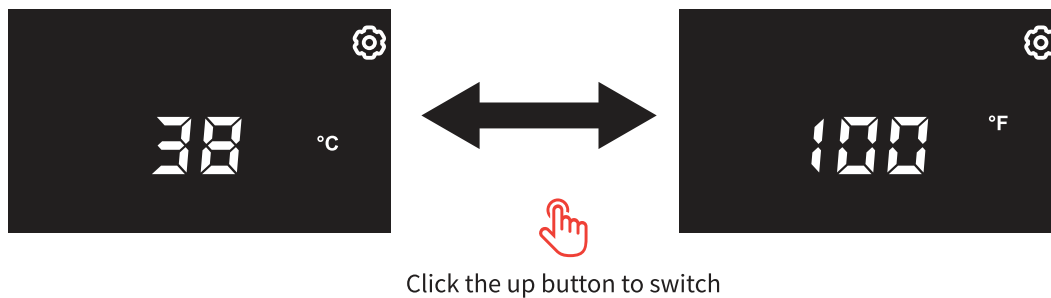
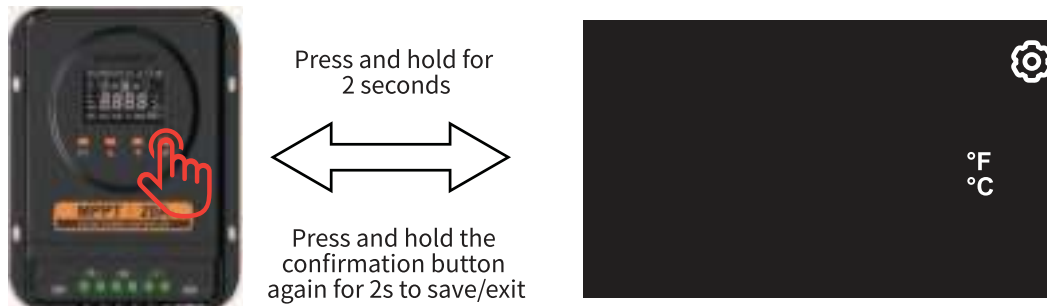

Connect the temperature sensor to the TEMP interface of the controller and attach OT interface of the other end to the battery electrode. The real-time battery temperature will be displayed. The default unit is Celsius, which can be switched to Fahrenheit.







5. Protection Indicators:

If an abnormality is detected, the home page will display an error code and the abnormal icon will flash. If multiple abnormalities exist, the one with the smallest code will be displayed until the abnormality is resolved and the original home page content is restored.

Protection	Display	Details
PV Over-voltage		If the PV voltage exceeds the maximum input open-circuit voltage of 95V, the controller triggers over-voltage protection and automatically stops charging the battery until the PV voltage drops below 90V.

<p>Charge overcurrent</p>		<p>If the charging current reaches 20A, over-current protection is triggered, and the controller automatically stops charging the battery.</p>
<p>Battery High Voltage</p>		<p>If the battery voltage exceeds the set value for the battery system, the controller triggers high-voltage protection and automatically stops charging the battery.</p>
<p>Battery Low Voltage</p>		<p>If the battery voltage falls below the set value for the battery system, the controller triggers low-voltage protection and automatically stops discharging.</p>
<p>Battery Overcharge</p>		<p>Based on the battery type's threshold, when the battery voltage reaches the overcharge protection point, the controller triggers overcharge protection and automatically stops charging the battery.</p>

<p>Discharge Overcharge</p>		<p>Based on the battery type's threshold, when the discharge current reaches the over-discharge protection point, the controller triggers discharge protection, turns off the load, and stops discharging.</p>
<p>Internal Temperature Overheat</p>		<p>internal temperature is too high, Normal operation resumes after the temperature drops</p>
<p>Battery Temperature Overheat</p>		<p>When the Battery temperature detected is $\geq 75^{\circ}\text{C}$, it will display an abnormal prompt (when Battery temperature $< 60^{\circ}\text{C}$, it will cancel abnormal prompt)</p>
<p>Load short circuit</p>		<p>When the load current value reaches the short-circuit protection value, the controller triggers the short-circuit protection of the load, shuts down the load and stops discharging.</p>

IX. Technical Parameters

1. Basic Technical Parameter

Model	L03DZMPPT20A-1
Nominal System Voltage	12V/24V auto-detection
Battery Rated Current	20A
Load Rated Current	20A
Max. Battery Voltage	32V
Max. PV Input Voltage	100V
Max. PV System Input Power	325W (12V)
	650W (24V)
Self-Consumption	≤2W
Communication Method	RS485、Bluetooth
Battery Type	Lithium Iron Phosphate (LFP), Flooded Lead Acid (FLD), Gel Lead Acid (GEL), Sealed Lead Acid (SLA)
Operating Temperature	-20°C~+60°C
Dimension	160.5*135*52.5mm/6.32*5.31*2.07in
Weight	0.74KG/1.63Lbs

2. Recommended Battery Charging Parameters

	Lithium Iron Phosphate (LFP)	Flooded Lead Acid (FLD)	Gel Lead Acid (GEL)	Sealed Lead Acid (SLA)	Custom (CUS)
Over-discharge Protection Voltage	11.2V	11.2V	10.7V	11.2V	11.2V
Over-charge Protection Voltage	15.0V	15.0V	15.0V	15.0V	15.0V
Over-discharge Recovery Voltage	13.0V	12.2V	12.0V	12.5V	12.2V

Over-discharge Protection Voltage	14.5V	14.6V	14.4V	14.2V	14.6V
Bulk Charge Voltage	14.5V	14.6V	14.4V	14.5V	14.6V
Float Charge Voltage	--	13.8V	13.7V	13.7V	13.8V
Balancing Charge Voltage	--	14.8V	--	14.6V	14.8V
Balancing Charge Time	--	120min	--	120min	120min

Notes:

- ① For 24V systems, multiply all parameters by 2.
- ② Lithium batteries only have the bulk charge stage. Lead-acid batteries have bulk-to-float or absorption-to-float stages. Gel batteries do not have the absorption charge stage.

X. APP Usage

1. Installing Mobile Software:

Download the ECO-WORTHY app from the Apple App Store or Google Play Store, or scan the QR code below. The app allows Bluetooth connection without the need for an account. For detailed usage.



(Apple App Store QR code)



(Google Play Store QR code)



(APP User Manual)

XI. Troubleshooting and Maintenance

Faults	Solutions
The LCD screen is not lit, and the controller appears to be without power	Use a multi-meter to check the battery voltage at the controller's battery terminals. The battery voltage must be at least 10VDC. If the voltage at the controller battery terminals is between 10 and 32VDC and the screen does not display the contents, contact an authorized dealer for service. If no voltage is detected, check the wiring.
The controller is not charging	Check the power connections. Use a multi-meter to directly check the array voltage at the MPPT solar input terminals. The input voltage must be higher than the battery voltage before charging begins. Check if the battery voltage displayed on the OLED screen is within the system's recognizable range.
The battery remains in a low-power or depleted state	Insufficient solar panels to generate enough energy for the system. Consider increasing the solar panel array. Insufficient battery capacity to store enough energy for the system. Consider increasing the battery pack capacity.
The load is not working	Check whether the load operating status is off, or the device triggers protection and the load switch is turned off. Please check if the load connection cable is correct and secure;

Precautions for Use:

1. Do not install the controller in a sealed space with FLD batteries, as it may cause dangerous gas accumulation.
2. Do not connect any inverters or battery chargers to the load terminals of the controller.
3. Disconnect the battery from the MPPT only after the solar input is disconnected.
4. Install the MPPT in a location that is not easily accessible, as the heat sink may become very hot during operation.
5. Pay attention to the abnormal indicator status. If the abnormal icon flashes, troubleshoot the issue immediately.
6. Ensure that the connected load power is within the rated power range of the controller to avoid prolonged overload operation.
7. Maintain a safe distance between the BLUETOOTH AND WIFI MODULE 2.0 and other electrical devices to avoid electromagnetic interference. A minimum distance of 30 cm from high-power devices and transformers is recommended.
8. Do not lose any items in the packing list, including accessories and the user manual.
9. If any abnormal situation occurs during product use, contact our after-sales service immediately.

XII. Technical Support

1) Customer service email:



E-mail: customer.service@eco-worthy.com

2) Company address: USA/Germany



Address(US): 10920 W Sam Houston Pkwy N, Suite 700, Houston, TX77064



Address(DE): ECO-Worthy Europe GmbH Otto-Hahn-Str. 20
61381 Friedrichsdorf - Köppern Germany

3) Customer service telephone numbers:

Tel(DE): +49 6175 6514 999

Tel(US&CA): 1-866-939-8222

Tel(UK): +44 7553 406988

Note:

Customer Service Hours:

US: Mon-Fri 8:30 AM - 6:00 PM (CST)

UK: Mon-Fri 9 AM - 5 PM (GMT)

DE: Mon-Fri 9 AM - 5 PM (CET)

If you cannot get through by phone, please send us an email.

4) Official website address:



Web: <https://www.eco-worthy.com/>

5) Official social media:



Facebook: <https://www.facebook.com/ecoworthy.store/>



Youtube: @ecoworthy



Tiktok: https://www.tiktok.com/@eco_worthy

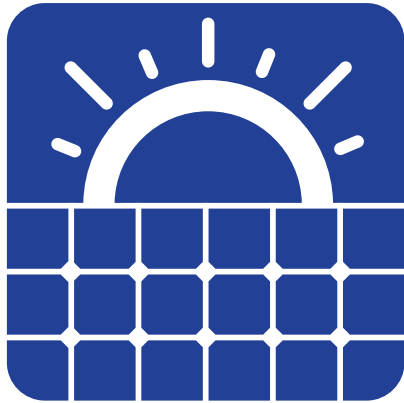

ECO-WORTHY

FCC WARNING

This device complies with part 15 of the FCC Rules. Operation is subject to the following two conditions: (1) this device may not cause harmful interference, and (2) this device must accept any interference received, including interference that may cause undesired operation.

Any changes or modifications not expressly approved by the party responsible for compliance could void the user's authority to operate the equipment.

NOTE: This equipment has been tested and found to comply with the limits for a Class B digital device, pursuant to Part 15 of the FCC Rules. These limits are designed to provide reasonable protection against harmful interference in a residential installation. This equipment generates, uses and can radiate radio frequency energy and, if not installed and used in accordance with the instructions, may cause harmful interference to radio communications.

However, there is no guarantee that interference will not occur in a particular installation. If this equipment does cause harmful interference to radio or television reception,

which can be determined by turning the equipment off and on, the user is encouraged to try to correct the interference by one or more of the following measures:

- Reorient or relocate the receiving antenna.
- Increase the separation between the equipment and receiver.
- Connect the equipment into an outlet on a circuit different from that to which the receiver is connected.
- Consult the dealer or an experienced radio/TV technician for help.

To maintain compliance with FCC's RF Exposure guidelines, This equipment should be installed and operated with minimum 20cm distance between the radiator and your body: Use only the supplied antenna.