

70 mm

70 mm

65 mm

/// PARKSIDE

PERFORMANCE

20 V / 4 Ah SMART-AKKU / 20V / 4Ah SMART BATTERY / 20 V / 4 Ah BATTERIE SMART PAPS 204 B1

(DE) (AT) (CH)

20 V / 4 Ah SMART-AKKU
Bedienungs- und
Sicherheitshinweise

(GB) (IE)

**20V / 4Ah SMART
BATTERY**
Operation and safety notes

(FR) (BE)

**20 V / 4 Ah BATTERIE
SMART**
Instructions d'utilisation et
consignes de sécurité

(NL) (BE)

20 V / 4 Ah SMART ACCU
Bedienings- en
veiligheidsinstructies

(PL)

**20 V / 4 Ah INTELIGENTNY
AKUMULATOR**
Wskazówki dotyczące obsługi
i bezpieczeństwa

(CZ)

**20 V / 4 Ah SMART
AKUMULÁTOR**
Pokyny pro obsluhu a
bezpečnostní pokyny

(SK)

**20 V/4 Ah SMART
AKUMULÁTOR**
Pokyny pre obsluhu a
bezpečnostné pokyny

(ES)

**20 V / 4 Ah BATERÍA
INTELIGENTE**
Instrucciones de utilización y
de seguridad

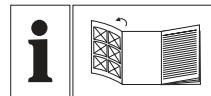

DE/AT/CH Bedienungs- und Sicherheitshinweise	Seite	5
GB/IE Operation and safety notes	Page	37
FR/BE Instructions d'utilisation et consignes de sécurité	Page	64
NL/BE Bedienings- en veiligheidsinstructies	Pagina	99
PL Wskazówki dotyczące obsługi i bezpieczeństwa	Strona	128
CZ Pokyny pro obsluhu a bezpečnostní pokyny	Strana	159
SK Pokyny pre obsluhu a bezpečnostné pokyny	Strana	186
ES Instrucciones de utilización y de seguridad	Página	214



OWIM GmbH & Co. KG
Stiftsbergstraße 1
74167 Neckarsulm
GERMANY

Model No.: HG12067
Version: 04/2025

IAN 481669_2410



IAN 481669_2410

(DE) (BE) (NL) (CZ)
(FR) (PL) (SK)

65 mm

70 mm

70 mm

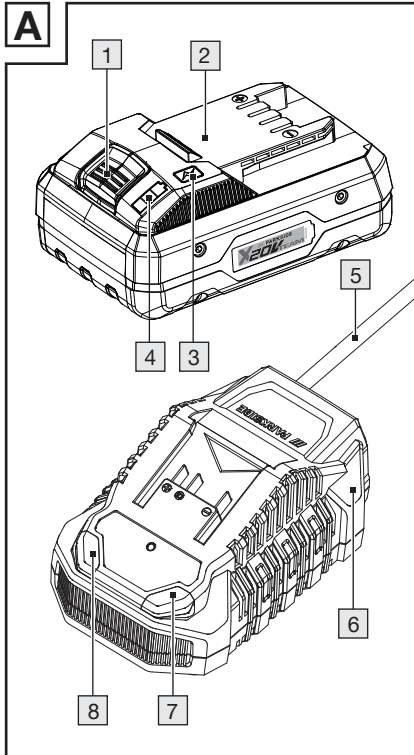

Warnings and symbols used	Page 39
Introduction	Page 41
Intended Use	Page 41
Contents	Page 42
Parts list	Page 42
Technical data.....	Page 43
General safety notes ...	Page 45
First use	Page 49
Charging the rechargeable battery	Page 49
Operation	Page 50
LED status	Page 50
Checking the rechargeable battery charge level.....	Page 50
Removing/inserting the rechargeable battery	Page 51

You will need (for use
with the PARKSIDE App) . . . Page 52

**Connecting the
battery to the
PARKSIDE app** Page 52

**Activating /
Deactivating Bluetooth** Page 54

Cleaning Page 56

Maintenance and storage Page 56

Disposal Page 57

**Simplified EU
declaration of conformity** Page 60







Warranty Page 60

Warranty claim procedure. . . Page 61

Service Page 63

Warnings and symbols used

The following warnings are used in this instruction manual, on the packaging and on the rating label:

	Follow the warnings and safety notes!
	Direct current/voltage
	Protect the battery pack against heat and continuous intense sunlight.
	Protect the battery pack against water and moisture.
	Protect the battery pack from fire.
	Read and observe the instruction manual.
	This symbol in combination with the word “Info” provides additional useful information.



The Bluetooth name and logo are registered trademarks owned Bluetooth SIG, Inc. and any use of such brand by OWIM GmbH & Co. KG is subject to a license. Other trademarks and brand names are the property of their respective owners.



Safety-relevant information
and other notes



Instructions for use

20V / 4Ah SMART BATTERY

● **Introduction**

We congratulate you on the purchase of your new product. You have chosen a high quality product. The instructions for use are part of the product. They contain important information concerning safety, use and disposal. Before using the product, please familiarise yourself with all of the safety information and instructions for use. Only use the product as described and for the specified applications. If you pass the product on to anyone else, please ensure that you also pass on all the documentation with it.

● **Intended Use**

The product is compatible with all devices from the Parkside X 20 V Team series. The product may only be charged using chargers from the Parkside X 20 V TEAM series.

This product is not intended for commercial use. Any other usage of or modification to the product is deemed to be improper and carries a significant risk of accidents. The manufacturer accepts no responsibility for damage(s) attributable to misuse.

● Contents

- 1 Smart Battery
- 1 Instruction manual

● Parts list

- 1 Release button for rechargeable battery
- 2 Rechargeable battery
- 3  button (charging level)
- 4 Charging level LEDs (red/orange/green)
- 5 Mains cord with mains plug
- 6 Rapid battery charger (not included)
- 7 Charging control LED – red
- 8 Charging control LED – green

● Technical data

Model no.:	HG12067
Battery:	PAPS 204 B1
Type:	Li-Ion (Lithium Ion)
Rated voltage:	max. 20V --- (Direct current)
Capacity:	4.0Ah
Cells:	5
Energy value:	80 Wh
Frequency performance:	$\leq 20\text{dBm}$
Frequency band:	2400 – 2483.5MHz
Recommended ambient temperature:	max. 45 °C
While charging:	+4 to +40 °C
During operation:	+4 to +40 °C
During storage:	+20 to +26 °C

To charge the rechargeable battery, only use the chargers from the Parkside X 20 V TEAM series.

Charging time for Battery PAPS 204 B1:

Charger	Charging time
PLG 20 A4, PLG 20 C1	120 minutes
PLG 20 A3, PLG 20 C3, PDSLGL 20 A1	60 minutes
Smart PLGS 2012 A1	45 minutes

NOTE: The actual charging time may be slightly different from the above stated depending on the ambient temperature and the condition of the battery pack. The information is subject to change without prior notice.

- Customers can order compatible replacement batteries and chargers from Lidl online shops for the following countries:

Germany (lidl.de), France (lidl.fr),
Belgium (lidl.be), Czech Republic (lidl.
cz), Netherlands (lidl.nl), Poland (lidl.
pl), Slovakia (lidl.sk), Spain (lidl.es)

Customers from all other countries can
order from www.optimex-shop.com.



General safety notes

⚠ WARNING! Read all safety warnings
and all instructions. Failure to follow the
warnings and instructions may result in
electric shock, fire and serious injury.

**SAVE ALL WARNINGS AND
INSTRUCTIONS FOR FUTURE
REFERENCE.**

- a) **Recharge only with the charger
specified by the manufacturer.**
A charger that is suitable for one type
of rechargeable battery may create
a risk of fire when used with another
rechargeable battery.

- b) Use power tools only with specifically designated rechargeable batteries.** Use of any other rechargeable batteries may create a risk of injury and fire.
- c) When the rechargeable battery is not in use, keep it away from other metal objects, like paper clips, coins, keys, nails, screws or other small metal objects, that can make a connection from one terminal to another.** Shorting the battery terminals together may cause burns or a fire.
- d) Under abusive conditions, liquid may be ejected from the rechargeable battery; avoid contact. If contact accidentally occurs, flush the affected area with water. If liquid contacts eyes, additionally seek medical help.** Liquid ejected from the battery may cause irritation or burns.



CAUTION! RISK OF EXPLOSION!



Never charge non-rechargeable batteries!



Protect the rechargeable battery from heat, for example from continuous exposure to sunlight, fire, water and moisture.



There is a risk of explosion.

- e) **Do not use a damaged or modified rechargeable battery with the tool.** Damaged or modified batteries exhibit unpredictable behaviour resulting in fire, explosion or risk of injury.
- f) **Do not expose a rechargeable battery or tool to fire or excessive temperature.** Exposure to fire or temperatures above 130 °C may cause an explosion.
- g) **Follow all charging instruction and do not charge the rechargeable**

battery or tool outside the temperature range specified in the instructions. Charging improperly or at temperatures outside the specified range may damage the battery and increase the risk of the fire.

- h)** The safety instructions of the compatible chargers must be observed.

Changes or modifications to this product not expressly approved by the party responsible for compliance could void the user's authority to operate the product.

NOTE: This equipment has been tested and found to comply with the limits for a Class B digital device, pursuant to part 15 of the FCC Rules. These limits are designed to provide reasonable protection against harmful interference in a residential installation. This equipment generates, uses and can radiate radio frequency energy and, if not installed and used in accordance with the instructions, may cause harmful interference to radio communications. However, there is no guarantee that interference will not occur in a particular installation. If this equipment does cause harmful interference to radio or television reception, which can be determined by turning the equipment off and on, the user is encouraged to try to correct the interference by one or more of the following measures:

- Reorient or relocate the receiving antenna.*
- Increase the separation between the equipment and receiver.*
- Connect the equipment into an outlet on a circuit different from that to which the receiver is connected.*
- Consult the dealer or an experienced radio/TV technician for help.*

This device complies with part 15 of the FCC Rules. Operation is subject to the following two conditions: (1) This device may not cause harmful interference, and (2) this device must accept any interference received, including interference that may cause undesired operation.

MODIFICATION: Any changes or modifications not expressly approved by the grantee of this device could void the user's authority to operate the device

SAVE THESE INSTRUCTIONS

Service

- a) Have your power tool serviced by a qualified repair person using only identical replacement parts.**

This will ensure that the safety of the power tool is maintained.

- b) Never service damaged battery packs.**

Service of battery packs should only be performed by the manufacturer or authorized service providers.

Radiation Exposure Statement

This device complies with FCC radiation exposure limits set forth for an uncontrolled rolled environment . This device should be installed and operated with a minimum distance of 5mm between the radiator and your body.

Declaration of Conformity European Notice



Hereby, Hangzhou Tuya Information Technology Co., Ltd declares that this module product is in compliance with essential requirements and other relevant provisions of Directive 2014/53/EU,2011/65/EU. A copy of the Declaration of conformity can be found at <https://www.tuya.com>.



This product must not be disposed of as normal household waste, in accordance with the EU directive for waste electrical and electronic equipment (WEEE -2012/19/EU). Instead, it should be disposed of by returning it to the point of sale, or to a municipal recycling collection point.

● First use

● Charging the rechargeable battery

① **INFO:**

- The rechargeable battery [2] may be charged at any time without reducing the service life. Interrupting the charging process does not damage the rechargeable battery.
 - Charge the rechargeable battery before use when it is at medium or low charging level.
 - The charging control LEDs (red [7] and green [8]) indicate the status of the charger [6] (not included) and the rechargeable battery (see Fig. A).
1. Insert the rechargeable battery [2] into the charger [6] (not included).
 2. Connect the mains plug [5] to a socket-outlet.
 3. When the rechargeable battery is fully charged, remove the rechargeable battery from the charger [6] (not

included). Disconnect the mains plug from the socket-outlet.

● Operation

● LED status

Red LED  lights up – The rechargeable battery  is charging.



Green LED  lights up – The rechargeable battery is fully charged.

Green and red LED flash – The rechargeable battery is defective.

Red LED flashes – The rechargeable battery is too cold or too warm.

Green LED lights up (without rechargeable battery) – The charger  is ready for use.

● Checking the rechargeable battery charge level

- Press the  button  to check the status of the rechargeable battery .

The status/remaining charge shows on the charging level LEDs **4** as follows (see Fig. A):

- Red + orange + green = maximum charge
- Red + orange = medium charge
- Red = low charge

● Removing/inserting the rechargeable battery

CAUTION! RISK OF INJURY!

- Only insert the rechargeable battery once the battery operated tool is ready for use.
- To insert the rechargeable battery **2**, place it on the guide track and push it into the charger **6**. The rechargeable battery audibly snaps into place.
- To remove the rechargeable battery from the charger, press the rechargeable battery release button **1** and pull out the rechargeable battery.



The **PARKSIDE** app can be used with this product when a **PARKSIDE** Smart Battery is installed.

● You will need (for use with the **PARKSIDE** App)



Mobile device:
iOS 15.0 or higher
Android 6.0 or higher

● Connecting the battery to the **PARKSIDE** app

Only Smart batteries can be connected to the PARKSIDE app

1. Enable Bluetooth function of mobile device
2. Run PARKSIDE app
3. Select 
4. Select the battery from the list

① If the Smart battery had already been connected before, such battery name will be shown on the list.

If there is no available battery on the list, it can be added by following steps.

1. Ensure Smart battery is paired with mobile device via Bluetooth.
2. Select **+** to **Add device**.
3. Follow the instructions in the app. The app scans the surroundings for available devices.
4. Select the battery want to be added.
5. Confirm the successful connection with “**Done**” or selecting “**Add more devices**” directly.
6. If needed, the added battery can be renamed by following the instruction in the app.

The battery is now listed under  of the connected devices and can be selected.

● Activating / Deactivating Bluetooth

To activate Bluetooth

- Press and hold the button **3** of rechargeable battery **2** for 5 seconds.
- Only the central yellow color LED of charging level LEDs **4** is glowed up.
- This indicates Bluetooth is activated.
- Release the button **3**.

To deactivate Bluetooth



- Press and hold the button **3** of rechargeable battery **2** for 10 seconds.
- Only central yellow color LED of charging level LEDs **4** glows up first then goes off.
- This indicates Bluetooth is deactivated.
- Release the button **3**.

① The battery icon appears with a white background under  in PARKSIDE app. It indicates that is in offline condition.



Features of the app

- First to select a battery from the list will lead to the overview page.
- For more detail information, select the .

Privacy policy

- It can be obtained from  **Privacy** at .

Disconnecting the device and deleting data from the app

- Go to  to select the device to be removed and delete those data.
- Press and hold the selection and swipe from the right to the left side of the screen .



Finding solutions with the app - FAQ

- Select .



- Select  access to Frequently Asked Questions (FAQ).
- Find out frequently asked questions and the corresponding answers.

● Cleaning

CAUTION! RISK OF INJURY AND DAMAGE!

- Never use flammable or combustible solvents around battery packs, charger, or tools.
- Clean out dust and debris from the vents and electrical contacts of the charger  and the rechargeable battery  using a soft brush.

● Maintenance and storage

- Only store the rechargeable battery  partially charged. The rechargeable battery should be charged to 40 to 60 % (red and orange LED of the charging level LEDs  light up) before storing for extended periods.

- Check the rechargeable battery charge about every 3 months when storing for extended periods. Recharge as necessary.

● Disposal

The packaging is made of environmentally friendly materials, which may be disposed of through your local recycling facilities.



Observe the marking of the packaging materials for waste separation, which are marked with abbreviations (a) and numbers (b) with following meaning: 1–7: plastics/20–22: paper and fibreboard/80–98: composite materials.

Product:



The product incl. accessories, manual and packaging materials are recyclable and are subject to extended producer responsibility.

Dispose them separately, following the illustrated Info-tri (sorting information), for better waste treatment.

The Triman logo is valid in France only.



Contact your local refuse disposal authority for more details of how to dispose of your wornout product.



To help protect the environment, please dispose of the product properly when it has reached the end of its useful life and not in the household waste. Information on collection points and their opening hours can be obtained from your local authority.

Faulty or used batteries/rechargeable batteries must be recycled. Return the batteries/rechargeable batteries and the product to the available collection points.



Environmental damage through incorrect disposal of the batteries / rechargeable batteries!

Remove the batteries / battery pack from the product before disposal.

Batteries / rechargeable batteries may not be disposed of with the usual domestic waste. They may contain toxic heavy metals and are subject to hazardous waste treatment rules and regulations. The chemical symbols for heavy metals are as follows:
Cd = cadmium, Hg = mercury, Pb = lead.
That is why you should dispose of used batteries / rechargeable batteries at a local collection point.

● Simplified EU declaration of conformity

 CE mark indicates conformity with relevant EU directives applicable for this product.

● Warranty

The product has been manufactured to strict quality guidelines and meticulously examined before delivery. In the event of material or manufacturing defects you have legal rights against the retailer of this product. Your legal rights are not limited in any way by our warranty detailed below.

The warranty for this product is 3 years from the date of purchase. The warranty period begins on the date of purchase. Keep the original sales receipt in a safe location as this document is required as proof of purchase.

Any damage or defects already present at the time of purchase must be reported without delay after unpacking the product.

Should the product show any fault in materials or manufacture within 3 years from the date of purchase, we will repair or replace it – at our choice – free of charge to you. The warranty period is not extended as a result of a claim being granted. This also applies to replaced and repaired parts.

This warranty becomes void if the product has been damaged, or used or maintained improperly.

The warranty covers material or manufacturing defects.

● **Warranty claim procedure**

So that your request can be processed quickly, please observe the following instructions:

For all inquiries, please have the receipt and item number (e.g., IAN 481669_2410) ready as proof of purchase.

The article number can be taken from the identification label on the product, engraving on the product, the front cover of your manual (at the bottom left), or the sticker on the back or bottom of the product.

If malfunctions or other defects arise, first contact the service department indicated below by phone or email.

You can then send a product recorded as defective to the communicated service address postage-free, making sure to enclose proof of purchase (receipt) and information on the details of the defect and when it occurred.

You can download and view this and numerous other manuals at parkside-diy.com. This QR code takes you directly to parkside-diy.com. Choose your country and use the search

screen to search for the operating instructions. Entering the item number (IAN) 481669_2410 takes you to the operating instructions for your item.



● Service

- GB** **Service Great Britain**
Tel.: 08000569216
E-Mail:owim@lidl.co.uk
- IE** **Service Ireland**
Tel.: 1800 200736
E-Mail:owim@lidl.ie