

19" TFT LCD COLOR MONITOR

Service
Service
Service



190EW9FB/00
190EW9FB/93
190EW9FB/05
190EW9FB/62



Service Manual

TABLE OF CONTENTS

Description	Page	Description	Page
Important Safety Notice	2	Scaler Board Schematic Diagram	21 ~ 23
Technical Data & Power Management	3 ~ 4	Power Board Schematic Diagram	24 ~ 25
Connection to PC	5	Button Board Schematic Diagram	26
OSD Menu Control Level Structure	6	Scaler Board Layout Side View	27
Advanced OSD Adjustment	7	Power Board Layout Side View	28
OSD Attention Signal	8	Exploded View	29
Safety and troubleshooting information	9	Recommended Parts List	30~33
Definition of Pixel Defects	10 ~ 11	Different Parts List	34
Wiring Diagram	12	General Trouble Shooting Guide	34~48
Mechanical Instructions	13 ~ 14	General Product Specification	49 ~ 61
F/W Upload Instructions	15 ~ 15	Safety Check Process	62
DDC Instructions	16 ~ 17		
DDC DATA	18 ~ 18		
Safety Instructions, Warnings and Notes	19		
Block Diagram	20		

SAFETY NOTICE

ANY PERSON ATTEMPTING TO SERVICE THIS CHASSIS MUST FAMILIARIZE HIMSELF WITH THE CHASSIS AND BE AWARE OF THE NECESSARY SAFETY PRECAUTIONS TO BE USED WHEN SERVICING ELECTRONIC EQUIPMENT CONTAINING HIGH VOLTAGES.

CAUTION: USE A SEPARATE ISOLATION TRANSFORMER FOR THIS UNIT WHEN SERVICING.

REFER TO BACK COVER FOR IMPORTANT SAFETY GUIDELINE.



Subject to modification Jul. 17th. 2008

Copyright 2008 Philips Consumer Lifestyle. All rights reserved. No part of this publication may be reproduced, stored in a retrieval system or transmitted, in any form or by means, electronic, mechanical, photocopying, or otherwise without the prior permission of Philips. Safety regulations require that the set is restored to its original condition and that parts which are identical with those specified are used.

PHILIPS

EN: 312278517990



Important Safety Notice

Proper service and repair is important to the safe, reliable operation of all Philips Consumer Electronics Company** Equipment. The service procedures recommended by Philips and described in this service manual are effective methods of performing service operations. Some of these service operations require the use of tools specially designed for the purpose. The special tools should be used when and as recommended.

It is important to note that this manual contains various CAUTIONS and NOTICES which should be carefully read in order to minimize the risk of personal injury to service personnel. The possibility exists that improper service methods may damage the equipment. It is also important to understand that these CAUTIONS and NOTICES ARE NOT EXHAUSTIVE. Philips could not possibly know, evaluate and advise the service trade of all conceivable ways in which service might be done or of the possible hazardous consequences of each way. Consequently, Philips has not undertaken any such broad evaluation. Accordingly, a servicer who uses a service procedure or tool which is not recommended by Philips must first satisfy himself thoroughly that neither his safety nor the safe operation of the equipment will be jeopardized by the service method selected.

** Hereafter throughout this manual, Philips Consumer Electronics Company will be referred to as Philips.

WARNING

Critical components having special safety characteristics are identified with a  by the Ref. No. in the parts list and enclosed within a broken line* (where several critical components are grouped in one area) along with the safety symbol  on the schematics or exploded views.

Use of substitute replacement parts which do not have the same specified safety characteristics may create shock, fire, or other hazards.

Under no circumstances should the original design be modified or altered without written permission from Philips. Philips assumes no liability, express or implied, arising out of any unauthorized modification of design. Servicer assumes all liability.

* Broken Line



FOR PRODUCTS CONTAINING LASER :

- DANGER - In visible laser radiation when open.
AVOID DIRECT EXPOSURE TO BEAM.
- CAUTION - Use of controls or adjustments or performance of procedures other than those specified herein may result in hazardous radiation exposure.
- CAUTION - The use of optical instruments with this Product will increase eye hazard.

TO ENSURE THE CONTINUED RELIABILITY OF THIS PRODUCT, USE ONLY ORIGINAL MANUFACTURER'S REPLACEMENT PARTS, WHICH ARE LISTED WITH THEIR PART NUMBERS IN THE PARTS LIST SECTION OF THIS SERVICE MANUAL.

Take care during handling the LCD module with backlight unit

- Must mount the module using mounting holes arranged in four corners.
- Do not press on the panel, edge of the frame strongly or electric shock as this will result in damage to the screen.
- Do not scratch or press on the panel with any sharp objects, such as pencil or pen as this may result in damage to the panel.
- Protect the module from the ESD as it may damage the electronic circuit (C-MOS).
- Make certain that treatment persons body are grounded through wrist band.
- Do not leave the module in high temperature and in areas of high humidity for a long time.
- Avoid contact with water as it may a short circuit within the module.
- If the surface of panel become dirty, please wipe it off with a soft material. (Cleaning with a dirty or rough cloth may damage the panel.)

Technical Data

1. General Specification

1.1 Panel characteristic		Input signal levels	: 700 mVpp
Panel source	: BOE HT190WG1-600	Sync. input signals	: Analog R/G/B separate inputs Separate horizontal and vertical / Composite (H+V) TTL level, Sync On Green (SOG) sync 0.3Vp-p Negative
Screen type	: TN+film		
Screen dimensions	: 19 inches (diagonal) 16:10		
BOE HT190WG1-600			
Resolution	: 1440 X 900 (WXGA+)	Input impedance (Digital)	: NA
Outside dimensions	: 428.0 (H) X 278.0 (V) X 18.5 (D)	Video interface	: Analog only
Pixel pitch (mm)	: 0.2835 x 0.2835		
		1.5 Physical characteristics	
Color pixel arrangement	: R. G. B. Vertical Stripe	Unit dimensions	
Display surface	: Hard-coating (3H), Non-glare type	- Width	: 437.4 mm
Color depth	: 16.7M colors	- Height	: 374.8mm
Backlight	: 4 lamps	- Depth	: 139.1 mm
Active area (mm) View angle (CR>10) Contrast ratio	: 408.24 (H) x 255.15(V) : 170 (H)/160(V) (typical) : 1000 : 1 (typical)	Packed unit dimensions	
White luminance	: 300 nits (7.0mA) (typical)	- Width	: 490.0mm
Color gamut	: 72% (typical)	- Height	: 138.0 mm
Response time	: 5 ms	- Depth	: 375.0 mm
		Packed unit dimensions (China only)	
		- Width	: 490.0 mm
		- Height	: 138.0 mm
		- Depth	: 375.0 mm
1.2 Scanning frequencies		Weight (monitor only)	: 4.0±0.2kg (Including I/F cable 240 g)
Horizontal scan range	: 30 - 83 K Hz (automatic)	Tilt angle	: -5° +/-2 (forward), +14° +/-3 (backward)
Vertical scan range	: 56 - 76 Hz (automatic)	Swivel angle	: nil
		Height adjustment	: nil
		Portrait display	: nil
		AC input: - voltage	: AC 90 - 264 V,
		- frequency	: 50 / 60 ± 2 Hz
		Power consumption	: 42W maximum
		Ambient temperature	: 0 to 40 degree C
1.3 Video		Operating	
Video dot rate	: < 156 MHz	- Temperature	: 0 to 40 degree C
Input impedance (Analog signal input)		- Humidity	: 90% (max.)
- video	: 75 ohm	- Altitude	: 0 - 3048 m
- Sync	: 2.2K ohm	Storage	
		- Temperature	: -20 to 60 degree C
		- Humidity	: 90% max
		- Altitude	: 0 to 9144m
		System MTBF	: 50,000 Hrs

Technical Data

2. Pin Assignment

2.1 PC analog video input with D - sub connector.

Connector type of analog signal cable :
D - Sub male with DDC2B pin assignment.
Blue connector with thumb-operated jackscrews.

Pin assignment :

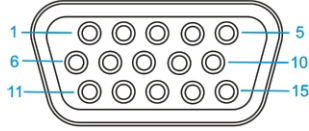

Pin	Symbol	Pin	Symbol	Pin	Symbol
1	Red	6	Red GND	11	GND
2	Green/SOG	7	Green GND	12	Bi-directional data
3	Blue	8	Blue GND	13	H sync
4	GND	9	+5V	14	V sync
5	CableDetect	10	Open	15	Data clock

Automatic Power Saving

If you have VESA / DPMS compliance display card or software installed in your PC, the monitor can automatically reduce power consumption when power saving function active. And if an input from keyboard, mouse or other devices is detected, the monitor will automatically wake up. The following table shows the power consumption and signaling of this automatic power saving feature:

Status	Power	LED	Remark
Power On	≤ 42W	Green	W/O Speaker
Power Saving	≤ 2W	Amber	
Power Off	≤ 1W	Off	

This monitor must comply with the Microsoft On Now specification, with two power management states, as defined by the VESA DPMS document. And must appropriately display the DPMS states. Also comply with Environmental Protection Agency (EPA) Energy Star and TCO03 power management standard strictly.



ENERGY STAR is a U.S. Registered mark. AS AN ENERGY STAR PARTNER, PHILIPS HAS DETERMINED THAT THIS PRODUCT MEETS THE ENERGY STAR GUIDELINES OF ENERGY EFFICIENCY.

Data Storage

Factory preset mode:

This monitor has 13 factory-preset modes as indicated in the following table:

Item	H.Freq. (KHz)	Mode	Resolution	V.Freq. (Hz)	BW(MHz)
1	31.469	IBM VGA 3H	720x400	70.087	28.3
2	31.469	IBM VGA 12H	640x480	59.94	25.18
3	35	MACINTOSH	640x480	67	30.24
4	37.5	VESA	640x480	75	31.5
5	35.156	VESA	800x600	56.25	36
6	37.879	VESA	800x600	60.317	40
7	46.875	VESA	800x600	75	49.5
8	48.363	VESA	1024x768	60.004	65
9	60.023	VESA	1024x768	75.029	78.75
10	63.981	VESA	1280x1024	60.02	108
11	79.976	VESA	1280x1024	75.025	135
12	55.935	VESA	1440x900	59.887	106.5
13	70.635	VESA	1440x900	74.984	136.8

Connection to PC

1. Connection to PC

Please follow the steps to connect your LCD Monitor to PC.

a. Assembly LCD Monitor with base

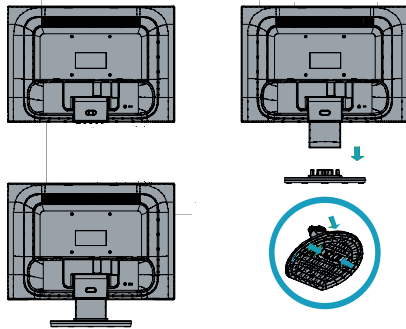

b. Connect to PC

- (1) Turn off your computer and unplug its power cable.
- (2) Plug the power cord of your computer and your monitor into a nearby outlet.
- (3) Turn on your computer and monitor. If the monitor displays an image, installation is complete.

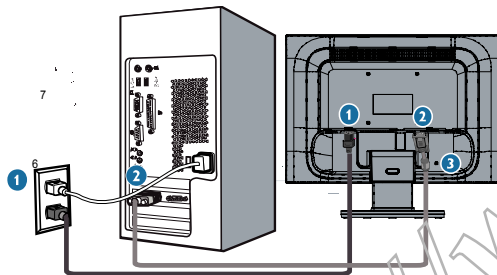

Port definition:

- (1) AC power input
- (2) VGA input
- (3) Kensington anti-theft lock

For best performance, use your Analog input and ensure that your display settings are set at 1440*900@60Hz.

c. Accessory Pack



Power cord

VGA cable

EDFU CD



Quick start Guide

2. Function key definition

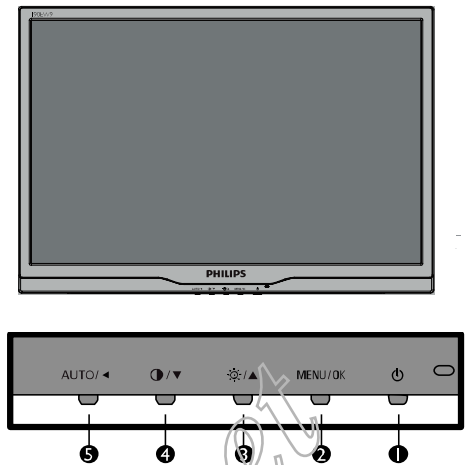

- (1) To switch monitor's power on and off.
- (2) To access OSD menu, enter the sub-menu, confirm the setting.
- (3) To adjust brightness of the display, go up in the Menu
- (4) To adjust contrast of the display, go down in the Menu
- (5) Automatically adjust the horizontal position, vertical position, phase and clock Settings/Return to previous OSD level.

3. Description of the On Screen Display

On-Screen Display(OSD) is a feature in all Philips LCD monitors. It allows an end user to adjust screen performance or select functions of the monitors directly through an on-screen instruction window. A user friendly on screen display interface is shown as below:

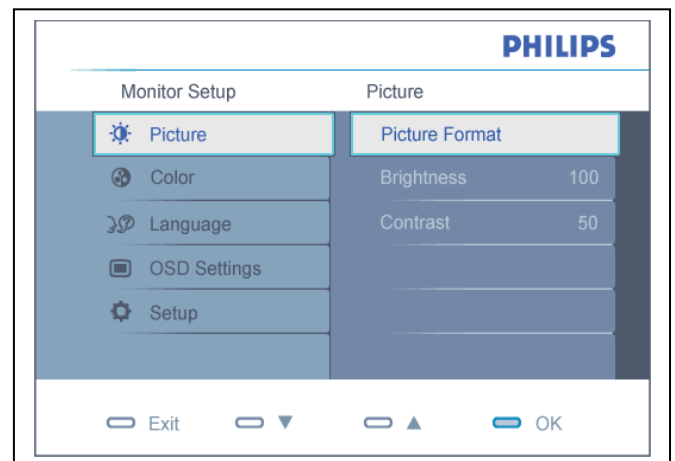

Basic and simple instruction on the control keys. According to the above OSD structure, users can :

- Press **▲** or **▼** button to move the cursor,
- Press **Menu** button confirm the choice or change.
- Press **▲** or **▼** button to adjust the value.
- Press **Menu** button to save the changes.
- Press **AUTO** button to automatically adjust the horizontal position, vertical position, phase and clock setting.

OSD Menu Control Structure

4.The OSD tree.

Below is an overall view of the structure of the On-Screen Display. You can use this as a reference when you want to work your way around the different adjustments later on.

4.1 Available for EU/AP Mode

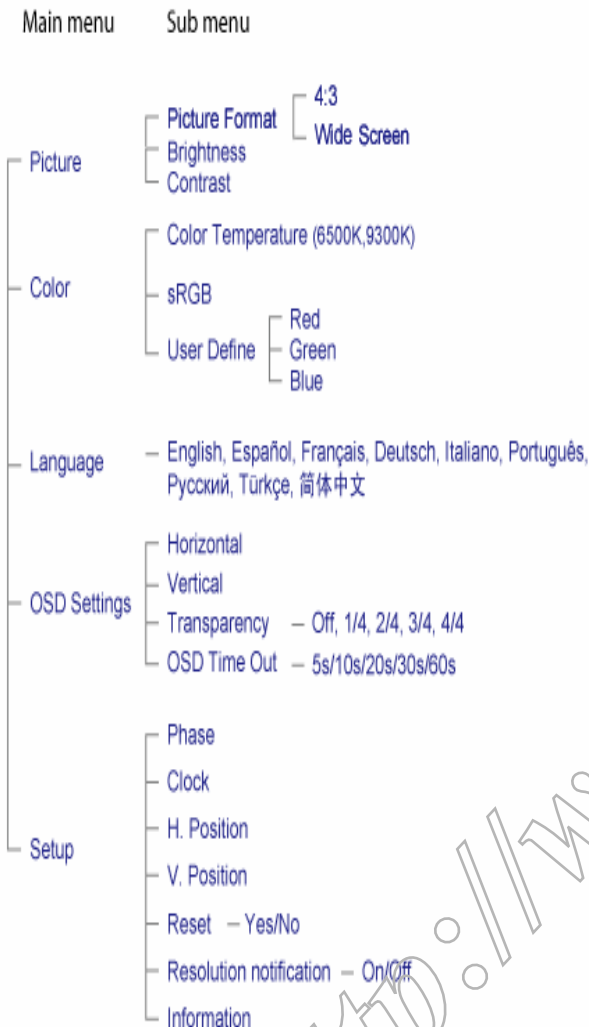

4.2 Available for China Model

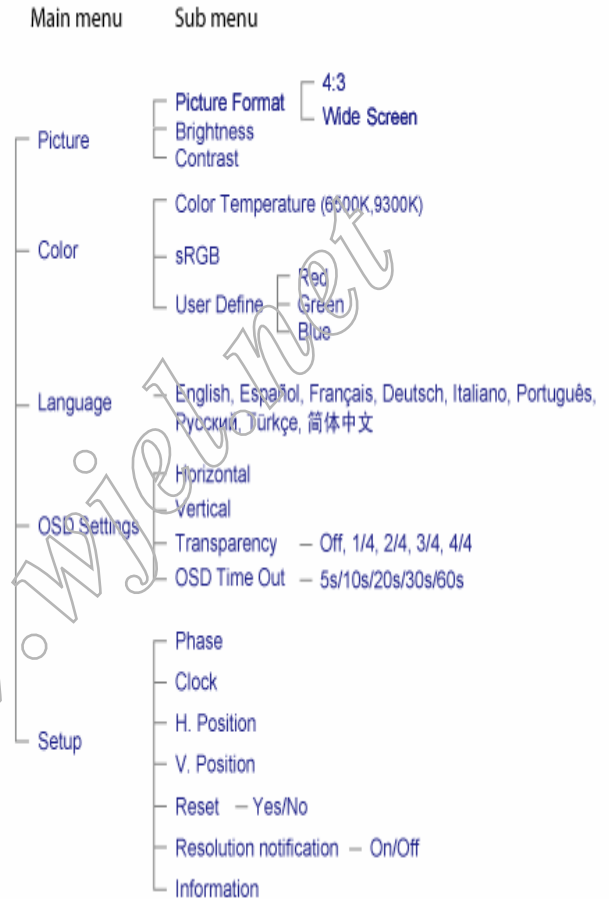

Note:

sRGB is a standard for ensuring correct exchange of colors between different devices(e. g. Digital cameras, monitor, printers, scanners, etc.)

Using a standard unified color space, sRGB will help represent pictures taken by an sRGB compatible device correctly on your sRGB enabled Philips monitor. In that way, the colors are calibrated and you can rely on the correctness of the colors shown on your screen.

Important with the use of sRGB is that the brightness and contrast of your monitor is fixed to a predefined setting as well as the color gamut. Therefore it is important to select the sRGB setting in the monitor's OSD.

To do so, open the OSD by pressing the OK button on the side of your monitor. Move the down button to go to color and press OK again. Use the right button to go to sRGB. Then move the down button and press OK again to exit the OSD.

After this, please do not change the brightness or contrast setting of your monitor. If you change either of these, the monitor will exit the sRGB mode and go to a color temperature setting of 6500K.

Advanced OSD Adjustment

Advanced OSD Adjustment

1. Front control panel

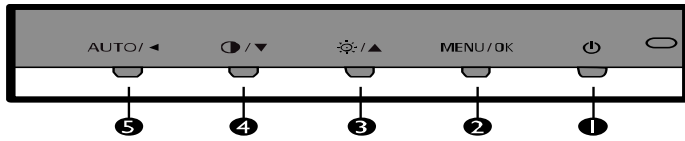

2. To Lock/Unlock OSD function

The OSD function can be locked by pressing **MENU** button for more than 6 seconds, the screen shows following windows for 5 seconds.

Every time when you press any button, this message appears on the screen automatically.

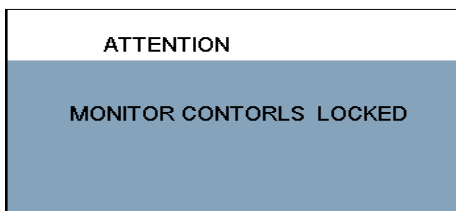

Locked OSD function can be released by pressing **MENU** button for more than 6 seconds. While press **MENU** button for OSD unlocked purpose, the screen will keep showing OSD MAIN MENU LOCKED until OSD function unlocked and screen automatically shows following window for 5 seconds.

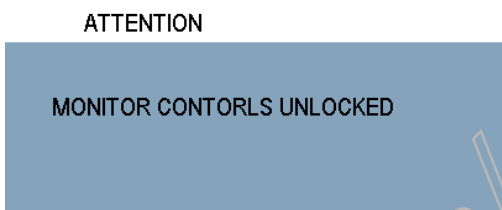

3. Access Factory Mode

Press **POWER** button to Power off, then Press **AUTO + MENU** at the same time, and then press **[POWER]** for DC power on. OSD menu will be shown with "Factory" on the sub -menu of picture. Select "Factory" for entering factory mode.

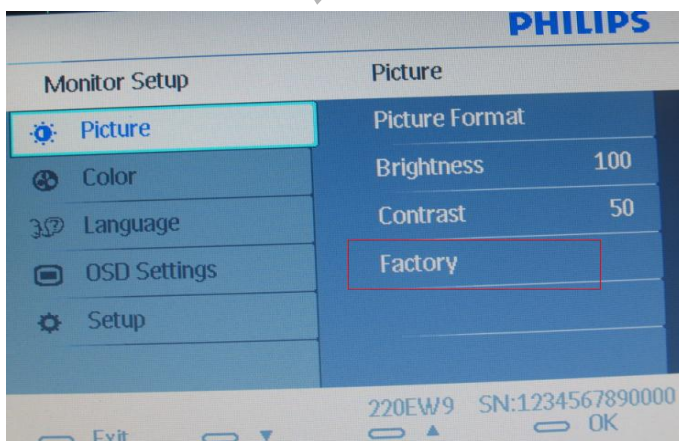

If this message appeared, means monitor already entered the factory mode.

4. Entering Burn-in mode and others

If you access into factory mode, press **MENU-PICTURE-FACTORY**, then press **MENU** to confirm, OSD menu will convert into another format as below:

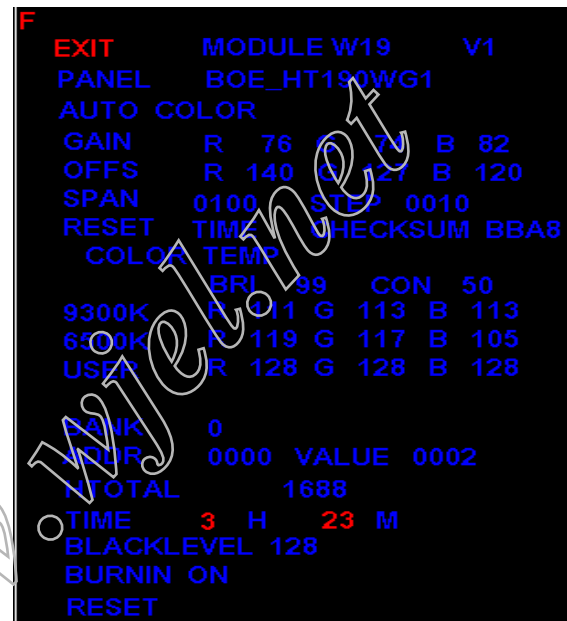

Move the cursor by **MENU** button, and press the **UP** or **DOWN** button to change the burn-in mode from On to Off.

Leave factory mode by simply power off(DC off) the monitor.

Warning:

* If you only want to enter burn in mode, please don't change any other setting items as above listed.

Appendix:

Explanation of above listed selections.

Selection	Description
Burn in On/Off	Enter Aging Mode
Auto Color	Auto Color Adjustment
Con	Contrast Adjustment
Bri	Brightness Adjustment
Gain	ADC Gain Value Adjustment (Auto adjustment by H/W when implement Auto Color function)
Offset	ADC Offset Value Adjustment (Auto adjustment by H/W when implement Auto Color function)
9300K	9300K Color Temperature Gain Value Adjustment
6500K	6500K Color Temperature Gain Value Adjustment
Reset	Memory Racall To Factory Default Settings

OSD Attention Signals

Clock & Phase Adjustment

Due to the different quality of video signal generated from graphics cards. It is necessary to adjust CLOCK and PHASE functions for the optimal video display of LCD monitor. So maybe some flicker appeared as Fig.1 & 2.



Fig.1



Fig.2

Following steps will guide you to make correct adjustment of CLOCK and PHASE:

- a. Restart your computer.
- b. Press **MENU** to bring up OSD menu after the OS (Operation System) boot up.
- c. Press **UP** or **DOWN** to select the option of **setup** and then press **MENU** to bring up its submenu as shown in Fig.3.
- d. Select the **Clock** or **Phase** adjustment items in submenu and press **UP** or **DOWN** to adjust.
(If the phenomenon as Fig.1, you should adjust "Phase")
(If the phenomenon as Fig.2, you should adjust "Clock")
- e. Quit OSD by press **MENU** button to save the settings.

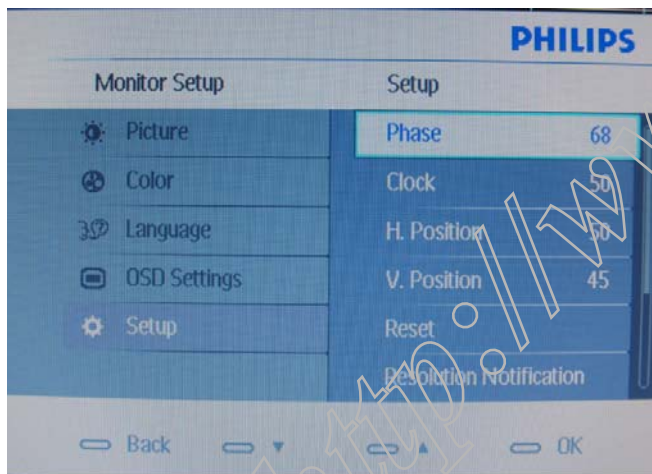

Fig.3

However, CLOCK and PHASE functions are only available while analog video signal is supplied. Operating unit under digital signal state, the video clock information can be obtained from graphics cards directly. So, it is unnecessary to adjust these functions.

OSD Attention signal

The monitor will detect various display situation automatically. When the monitor detects the problems, the screen will show the different warning signals to remind you what is happen to your monitor.

1. CHECK CABLE CONNECTION

This screen appears if there is no video signal input. Please check that the signal cable is properly connected to the video card of PC and make sure PC is on.

ATTENTION

CHECK CABLE CONNECTION

2. AUTO ADJUSTMENT

This screen appears when you touch the **AUTO** button. It will disappear when the monitor is properly adjusted.

Auto Adjustment

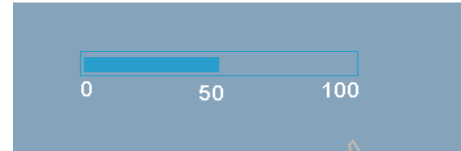

3. USE 1440X900@60HZ FOR BEST RESULT

This message appears when the video mode input is not the recommended 1440*900. Other modes may result in some picture distortion. Please adjust the video mode to 1440*900 at 60Hz for best display quality.

ATTENTION

USE 1440X900@60HZ
FOR BEST RESULT

4. 85HZ OVERDRIVE MESSAGE

This message appears when the video mode input is more than 85 HZ. The message "THIS IS 85HZ OVERDRIVE, CHANGE COMPUTER DISPLAY INPUT TO 1440X900@60HZ" is warmed, around 5 seconds in each minutes, after 10 minutes will go into power saving mode.

ATTENTION

THIS IS 85HZ OVERDRIVE,
CHANGE COMPUTER DISPLAY
INPUT TO 1440X900@60HZ

5. NO VIDEO INPUT → ENTERING SLEEP MODE

If input VGA you are selecting is not signal input, following message will appear on the screen.

ATTENTION

NO VIDEO INPUT

After 5 s, the monitor will go into power saving mode, following message will appear on the screen.

ATTENTION

ENTERING SLEEP MODE

Please check that the signal available is properly connected to the video card of PC and make sure PC is on.

Safety and Troubleshooting Information

Safety precautions and maintenance

WARNING: Use of controls, adjustments or procedures other than those specified in this documentation may result in exposure to shock, electrical hazards and/or mechanical hazards.

Read and follow these instructions when connecting and using your computer monitor:

- a. To protect your display from possible damage, do not put excessive pressure on the LCD panel. When moving your monitor, grasp the frame to lift; do not lift the monitor by placing your hand or fingers on the LCD panel.
- b. Unplug the monitor if you are not going to use it for an extensive period of time.
- c. Unplug the monitor if you need to clean it with a slightly damp cloth. The screen may be wiped with a dry cloth when the power is off. However, never use alcohol, solvents or ammonia-based liquids.
- d. Consult a service technician if the monitor does not operate normally when you have followed the instructions in this manual.
- e. The casing cover should be opened only by qualified service personnel.
- f. Keep the monitor out of direct sunlight and away from stoves or any other heat source.
- g. Remove any object that could fall into the vents or prevent proper cooling of the monitor's electronics.
- h. Do not block the ventilation holes on the cabinet.
- i. Keep the monitor dry. To avoid electric shock, do not expose it to rain or excessive moisture.
- j. When positioning the monitor, make sure the power plug and outlet are easily accessible.
- k. If turning off the monitor by detaching the power cable or DC power cord, wait for 6 seconds before attaching the power cable or DC power cord for normal operation.
- l. To avoid the risk of shock or permanent damage to the set, do not expose the monitor to rain or excessive moisture.
- m. **IMPORTANT:** Always activate a screen saver program during your application. If a still image in high contrast remains on the screen for an extended period of time, it may leave an 'after-image' or 'ghost image' on front of the screen. This is a well-known phenomenon that is caused by the shortcomings inherent in LCD technology. In most cases, the afterimage will disappear gradually over a period of time after the power has been switched off. Be aware, that the afterimage symptom cannot be repaired and is not covered under warranty.
- o. **Warning for lifting monitor:** Do not use the area underneath the logo cover to grip or lift the monitor. Placing weight on the logo cover can cause it to break away from the body and cause the monitor to fall. When lifting the monitor, place one hand under the monitor's frame.

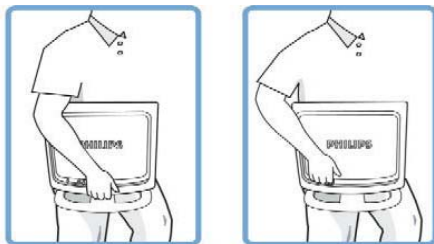

○ Do

✗ Don't

*Consult a service technician if the monitor does not operate normally when the operating instructions given in this manual have been followed.

Installation Locations

Avoid exposure to heat and extreme cold.

Do not store or use the LCD monitor in locations exposed to heat, direct sunlight or extreme cold.

Avoid moving the LCD monitor between locations with large temperature differences. Choose a site that falls within the following temperature and humidity ranges.

Temperature: 0-35°C 32-95°F

Humidity: 20-80% RH

Do not subject the LCD monitor to severe vibration or high impact conditions. Do not place the LCD monitor in the trunk of a car.

Take care not to mishandle this product by either knocking or dropping it during operation or transportation.

Do not store or use the LCD monitor in locations where there is a high level of humidity or in dusty environments. Do not allow water or other liquids to spill on or into the LCD monitor.

Trouble Shooting

This page deals with problems that can be corrected by the user. If the problem still persists after you have tried these solutions, contact your nearest Philips dealer.

Common Problems	
Having this problem	Check these items
No Picture (Power LED not lit)	<ol style="list-style-type: none"> a. Make sure the power cord is plugged into the power outlet and into the back of the monitor. b. First, ensure that the power button on the front of the monitor is in the OFF position, then press it to the ON position.
No Picture (Power LED is amber or yellow)	<ol style="list-style-type: none"> a. Make sure the computer is turned on. b. Make sure the signal cable is properly connected to your computer. c. Check to see if the monitor cable has bent pins. d. The Energy Saving feature may be activated.
Screen says	<ol style="list-style-type: none"> a. Make sure the monitor cable is properly connected to your computer. (Also refer to the Quick Set-Up Guide). b. Check to see if the monitor cable has bent pins. c. Make sure the computer is turned on.
AUTO button not working properly	<ol style="list-style-type: none"> a. The Auto Function is designed for use on standard Macintosh or IBM-compatible PCs running Microsoft Windows. b. It may not work properly if using nonstandard PC or video card. c. Make sure the computer is turned on.
Imaging Problems	
Display position is incorrect	<ol style="list-style-type: none"> a. Press the Auto button. b. Adjust the image position using the Phase/Clock of More Settings in OSD Main Controls.
Image vibrates on the screen	<ol style="list-style-type: none"> a. Check that the signal cable is properly connected to the graphics board or PC.
Vertical flicker appears	<ol style="list-style-type: none"> a. Press the Auto button. b. Eliminate the vertical bars using the Phase/Clock of More Settings in OSD Main Controls.
Horizontal flicker appears	<ol style="list-style-type: none"> a. Press the Auto button. b. Eliminate the vertical bars using the Phase/Clock of More Settings in OSD Main Controls.

Definition of Pixel Defects

The screen is too bright or too dark	Adjust the contrast and brightness on On-Screen Display. (The backlight of the LCD monitor has a fixed life span. When the screen becomes dark or begins to flicked, please contact your sales representative).
An after-image appears	If an image remains on the screen for an extended period of time, it may be imprinted in the screen and leave an after-image. This usually disappears after a few hours.
An after-image remains after the power has been turned off	This is characteristic of liquid crystal and is not caused by a malfunction or deterioration of the liquid crystal. The after-image will disappear after a period of time.
Green, red, blue, dark, and white dots remains	The remaining dots are normal characteristic of the liquid crystal used in today's technology.
For further assistance, refer to the Consumer Information Centers list and contact your local Philips distributor.	

Definition of Pixel Defects

This section explains the different types of pixel defects and defines acceptable defect levels of each type. In order to quality for repair or replacement under warranty, the number of pixel defects on a TFT LCD panel must exceed these acceptable levels.

1. Definition of Pixels and Sub-pixels

A pixel, or picture element, is composed of three sub pixels in the primary colors of red, green and blue. Many pixels together form an image. When all sub pixels of a pixel are lit, the three colored sub pixels together appear as a single white pixel. When all are dark, the three colored sub pixels together appear as a single black pixel. Other combinations of lit and dark sub pixels appear as single pixels of other colors.

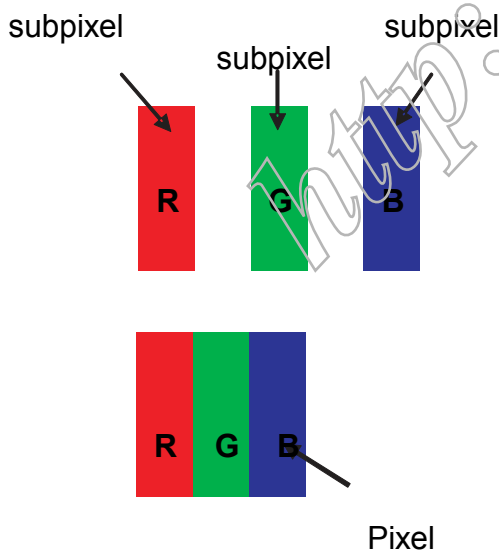

2. Types of Pixel Defects

Pixel and sub pixel defects appear on the screen in different ways. There are two categories of pixel defects and several types of sub pixel defects within each category.

Bright Dot Defects

Bright dot defects appear as pixels or sub pixels that are always lit or 'on'. That is, a bright dot is a sub-pixel that stands out on the screen when the monitor displays a dark pattern. There are the types of bright dot defects:

One lit red, green or blue sub pixel

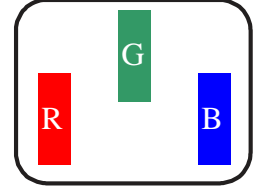

Two adjacent lit sub pixels:

Red + Blue = Purple
Blue + Green = Yellow
Green + Blue = Cyan (Light Blue)

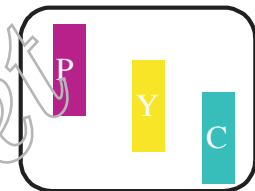

Three adjacent lit sub pixels (one white pixel!)



A red or blue bright dot must be more than 50 percent brighter than neighboring dots while a green bright dot is 30 percent brighter than neighboring dots.

Black Dot Defects

Black dot defects appear as pixels or sub pixels that are always dark or 'off'. That is, a dark dot is a sub-pixel that stands out on the screen when the monitor displays a light pattern. These are the types of black dot defects:

One dark sub pixel



Two or three adjacent dark sub pixels

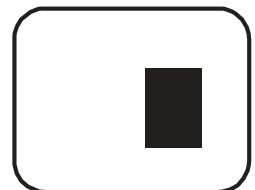

Definition of pixel defects

3. Proximity of Pixel Defects

Because pixel and sub pixels defects of the same type that are near to one another may be more noticeable, Philips also specifies tolerances for the proximity of pixel defects.

Perfect Panel - ISO 13406-2 Class II compliant do-defect-free-display.

MODEL	190EW9
1 lit subpixel	3
2 adjacent lit subpixels	1
3 adjacent lit subpixels (one white pixel)	0
Distance between two bright dot defects*	15mm
Bright dot defects within 20 mm circle	0
Total bright dot defects of all types	3

MODEL	190EW9
1 dark subpixel	5
2 adjacent dark subpixels	2
3 adjacent dark subpixels (one white pixel)	1
Distance between two dark dot defects*	15mm
Black dot defects within 20 mm circle	1
Total black dot defects of all types	5

MODEL	190EW9
Total bright or black dot defects of all types	5

Note:

* 1 or 2 adjacent sub pixel defects = 1 dot defect

Wiring Diagram

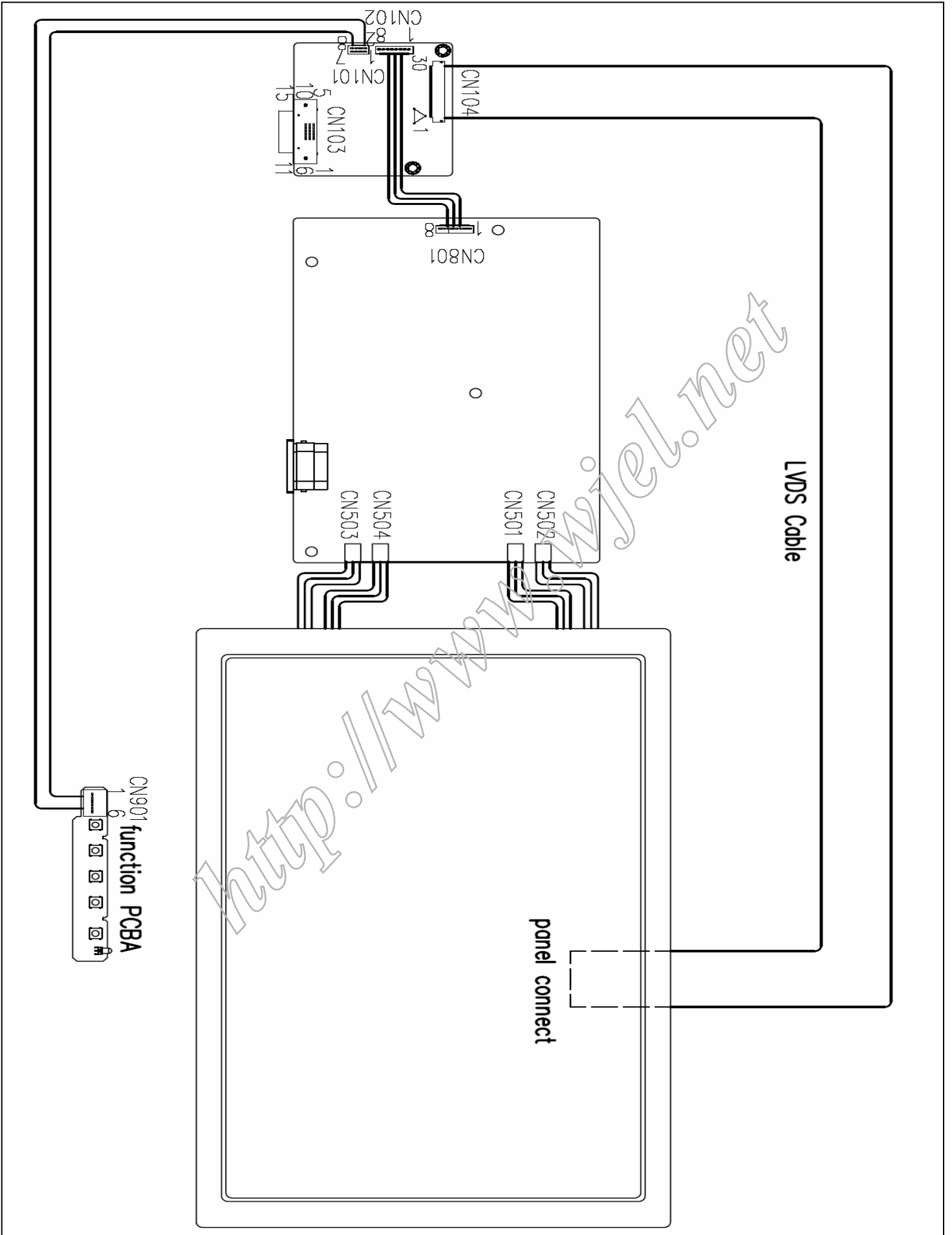

Mechanical instructions

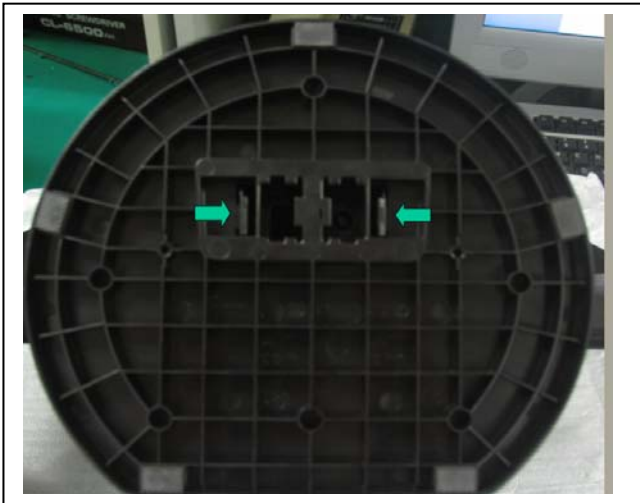

1. Press the release button, Then take off the base.

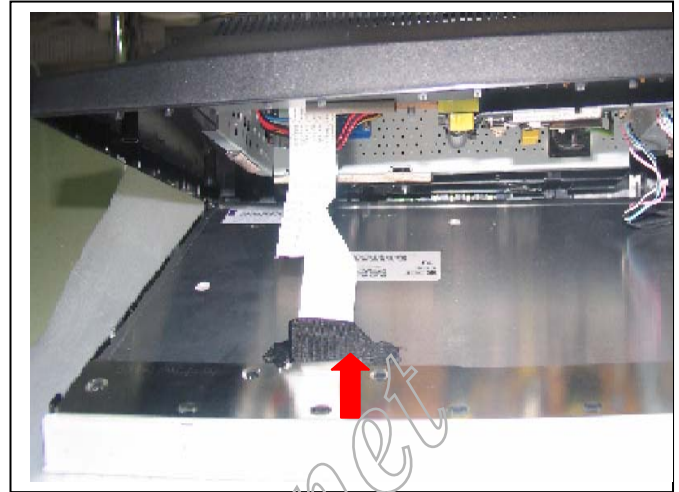

4. Reserve the Monitor then Panel come off. Disconnect the tape and LVDS cable from panel.



2. Press the release button, Then take off the stand down.

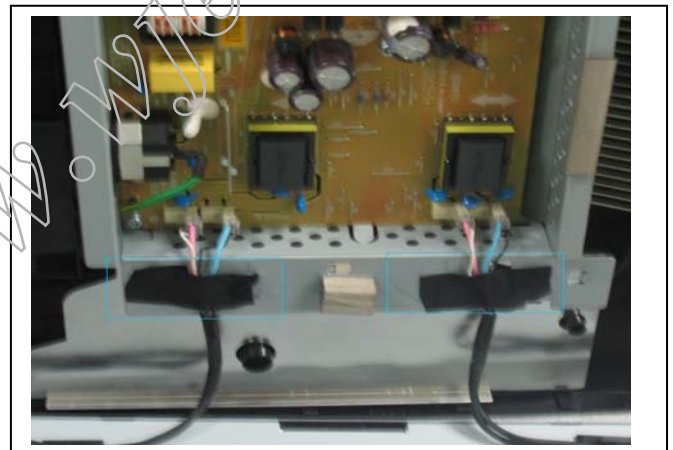

5. Tear off the tape from the lamp cable.



3. Take off the front bezel.

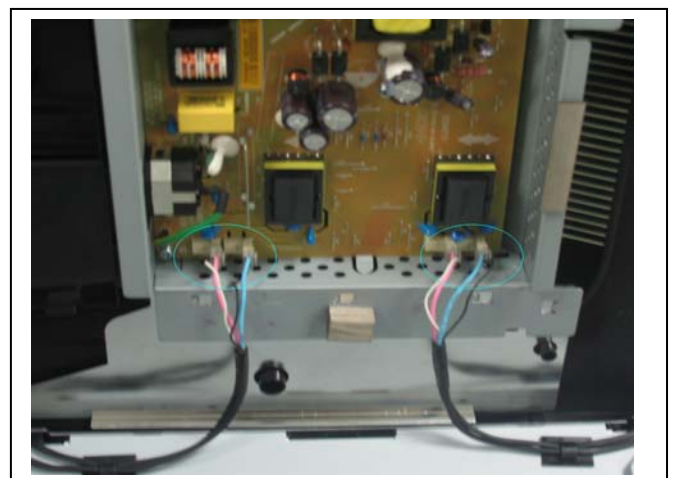

6. Disconnect the lamp cable from Power board.



7. Remove 2PCS attach VGA connect screw.



11. Remove 2pcs screw from the join of stand up & hinge, Then take off the stand up.



8. Release 5pcs screw form P/B & IF/B.



12. Remove 2pcs screw from the join of hinge & backcover, Then take off the hinge.



9. Take off the chassis.

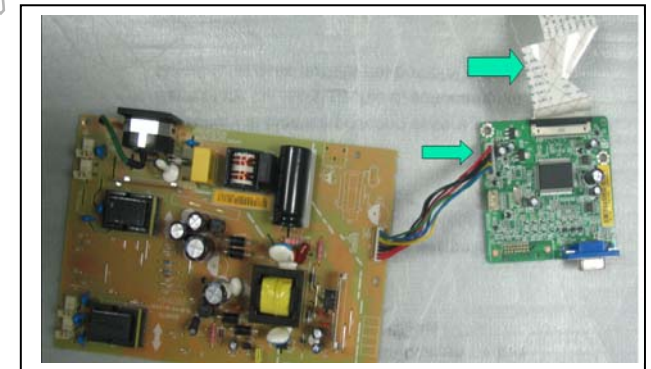

13. Disconnect the connector and LVDS from IF board.

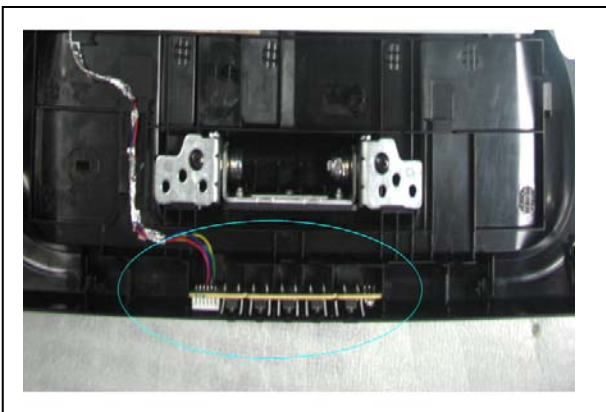

10. Take off the cable of function key.



14. Service position.

Electrical instructions

F/W upload instruction

Configuration and procedure (ISP Tool)

"ISP Tool" software is provided by NOVATEK to upgrade the firmware of Scaler IC. It is a windows-based program, which cannot be run in MS-DOS.

System and equipment requirements:

1. An i486 (or above) personal computer or compatible.
2. Microsoft operation system Windows 98/2000/XP.
3. ISP software " EasyUSB Writer V4.0 ".
(Need to install, it can not be performed directly. Double press "EasyUSB Writer V4.0.exe" to start installing, then chose the path that you want to install ,then it will perform automatically.)
4. Firmware uploading tool, as shown in Fig1.



Fig1

- * Connect the firmware uploading tool as Fig.1 shown.
- * Before the servicer perform the ISP Tool program, the Communicating connection must be well done. The USB port connects to the computer. VGA port connects to the Monitor.
- * When the connection fixed, power on the monitor. Setup and perform the ISP Tool program

1. Save the software in your PC, and create a shortcut on the desktop.
2. Double click the ISP Tool. exe icon at the desktop then appears window as shown in Fig. 2.

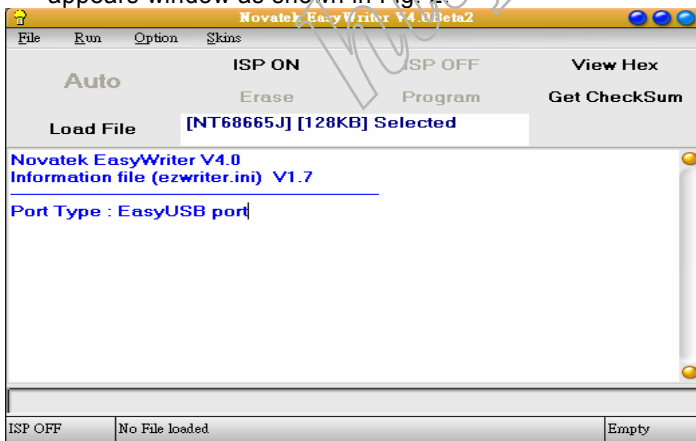

Fig. 2

3. Press the "Load File" button then select the path that save hex file , then chose file type as "Bank Switch(128K,256K)" as shown:

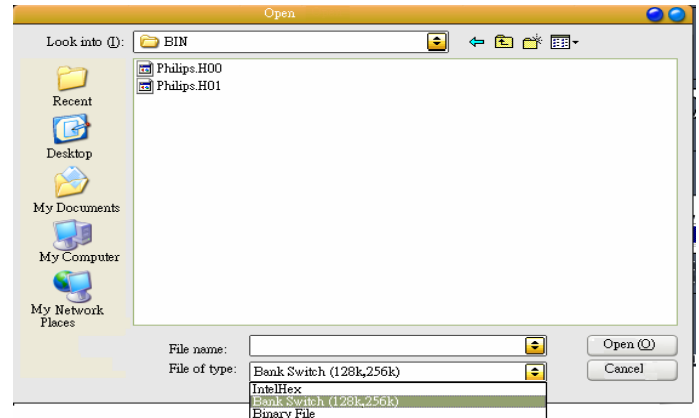
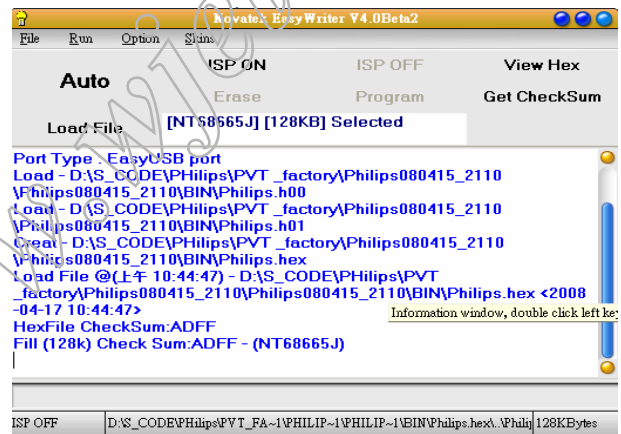

Fig3

4. Double press the "H00" file or "H01 file" ,then it acquires the hex file automatically, and a message will be showed in the dialog box to notice the operator . At this moment, please verify the checksum of the hex file with the firmware control table to make sure the suitable file will be used. Mentioned firmware control table will be provided by suppliers shown in Fig. 4.



5. Press the "ISP ON" button ,then the dialog box will has the information "ISP ON",else has the information "ISP Fail".If the information is "ISP Fail ,check the connectivity ,then try it again as shown in Fig. 5.

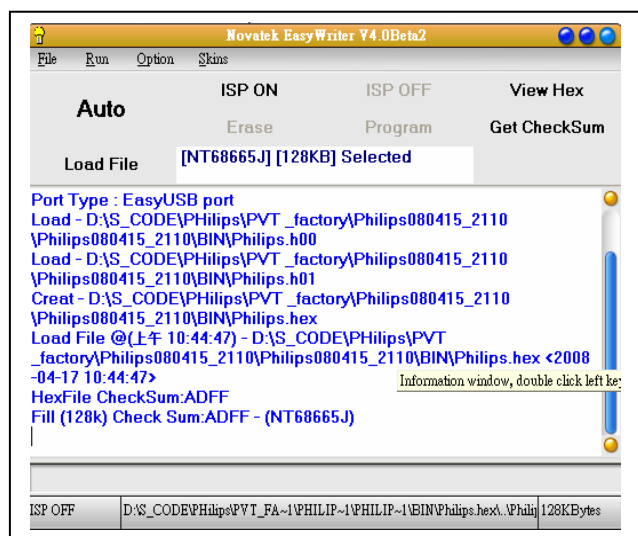

Fig. 5.

DDC instructions

6. Press “**Auto**” button of the toolbox. Program will perform the loading process automatically. When the loading process completed, and the dialog box appeared the message of Programing Success. If Program perform fail ,resume step 5.

DDC Data Re-programming

In case the DDC data main EEPROM which storage all factory settings were replaced due to a defect, the serial numbers have to be re-programmed
It is advised to re-soldered DDC IC and main EEPROM from the old board onto the new board if circuit board have been replaced, in this case the DDC data does not need to be re-programmed.

* According to the design concept of this product, DDC data of VGA interface are saved in EEPROM(IC 24C02)

Additional information

Additional information about DDC (Display Data Channel) may be obtained from Video Electronics Standards Association (VESA). Extended Display Identification Data(EDID) information may be also obtained from VESA.

System and equipment requirements

1. An i486 (or above) personal computer or compatible
2. Microsoft operation system Windows 98/2000/XP
3. Installation software of "EDID_Tool_3.7"
4. Executive program "EDID_Tool_3.7.exe"
5. ISP tool kit, as shown in Fig1

Connect the EDID tool as follow in Fig1: The parallel port connects to the computer. VGA port connects to the Monitor. Including: a. Alignment fixture x 1

- b. Printer cable (LPT type) x 1
- c. D-sub to D-sub cable x 1

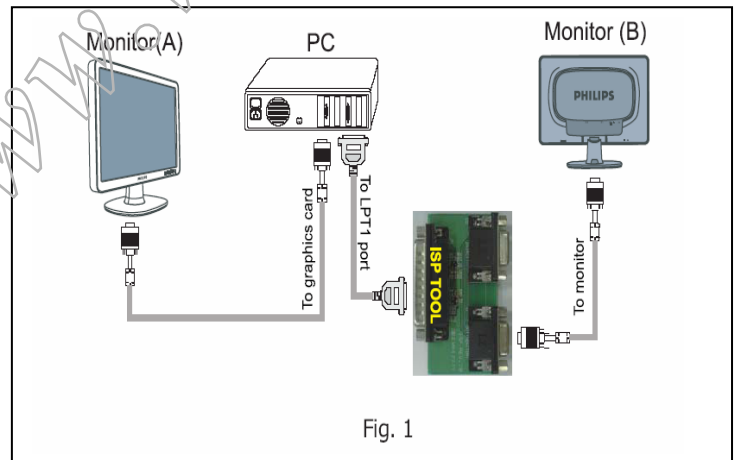

Fig. 1

Fig 1

Install and setup EDID_Tool_3.7 program

- Step 1: Double press the “EDID_Tool_3.7.exe”,as follow:
- Step 2: The EDID Tool Install finished.

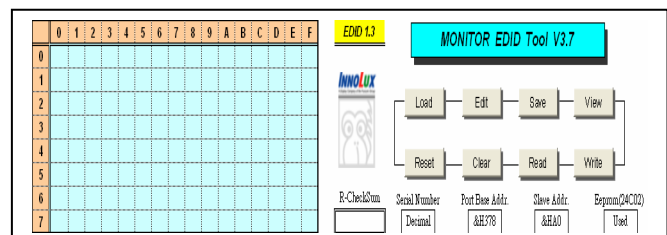

Fig 2

Re-programming Analog DDC IC

Step 1: After initialize the alignment fixture, connecting all cables. Be using VGA port from monitor.

Step 2: Connect the power code of monitor and power on it.

Step 3: Double check the EDID_Tool_3.7 icon to run the EDID_Tool_3.7.exe.

Step 4: Click the LOAD icon at the main menu to open the DDC files, load the files into EDID Tool, The EDID table will be appeared automatically as shown in below photos.

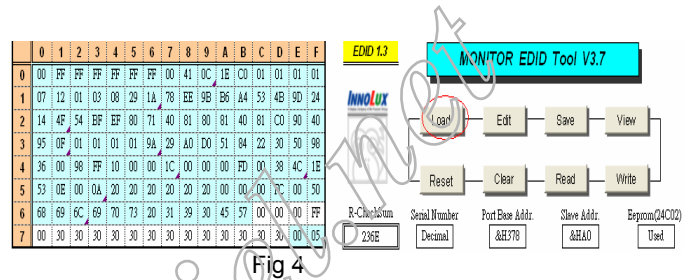

Fig 4

Step 5: In the “Detailed Timings”, key in the monitor serial number.

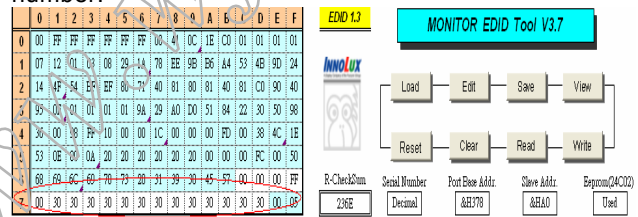

Fig 5

Step 6: Press “Write” button in the tool main ,when the DDC data download into the monitor, the message will be appeared automatically as shown in below photos.

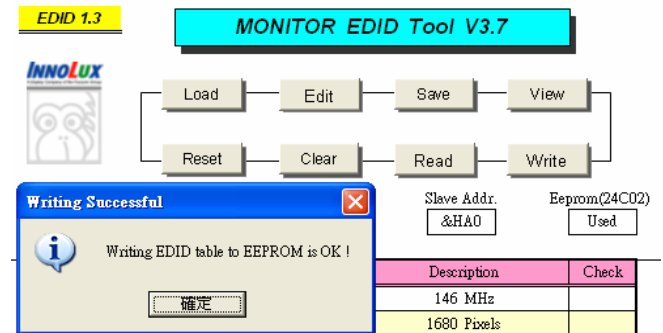

Fig 6

DDC Data

THE DISPLAY DATA CHANNEL (DDC_2B) CONTENT INCLUDING:
(Analog mode)

128 BYTES OF EDID CODE :

	0	1	2	3	4	5	6	7	8	9	A	B	C	D	E	F
0	00	FF	FF	FF	FF	FF	FF	00	41	0C	1E	C0	01	01	01	01
1	07	12	01	03	0E	29	1A	78	EE	9B	B6	A4	53	4B	9D	24
2	14	4F	54	BF	EF	80	71	40	81	80	81	40	81	C0	90	40
3	95	0F	01	01	01	01	9A	29	A0	D0	51	84	22	30	50	98
4	36	00	98	FF	10	00	00	1C	00	00	00	FD	00	38	4C	1E
5	53	0E	00	0A	20	20	20	20	20	20	00	00	00	FC	00	50
6	68	69	6C	69	70	73	20	31	39	30	45	57	00	00	00	FF
7	00	30	30	30	30	30	30	30	30	30	30	30	30	30	00	FF

(08~09h) ID Manufacturer Name=PHL

(0A~0Bh) Product ID Code= C01E

(0C~0Fh) Last 5 Digits of Serial Number= NOT SPECIFIED

(10h) Week of Manufacture=Product date

(11h) Year of Manufacture= Product date

(12h) EDID Version Number=1

(13h) EDID Revision Number=3

(14h) Video Input Definition: 0E
Analog Signal Level
0.700, 0.300 (1.000Vp-p)
No Blank -to-black Setup
Separate Syncs. Supported
Composite Sync. Supported
Sync. on Green Supported
No Serration Required

(15h) Max Horizontal Image Size=41 cm

(16h) Max Vertical Image Size=26 cm

(17h) Display Gamma=2.2

(18h) Power Management and Supported Feature(s): EE
Standby
Suspend
Active Off/Very Low Power
RGB Color Display
sRGB Color Space
Preferred Timing Mode
No Default GTF Supported

(19~22h) Chroma Info=

R (x, y) 0.643, 0.325
G (x, y) 0.295, 0.616
B (x, y) 0.143, 0.081
w (x, y) 0.310, 0.330

(23h) Established Timing I:

720 x 400 @ 70Hz
720 x 400 @ 88Hz (N/A)
640 x 480 @ 60Hz
640 x 480 @ 67Hz
640 x 480 @ 72Hz
640 x 480 @ 75Hz
800 x 600 @ 56Hz
800 x 600 @ 60Hz

(24h) Established Timing II:
800 x 600 @ 72Hz
800 x 600 @ 75Hz
832 x 624 @ 75Hz
1024 x 768 @ 87Hz(I) (N/A)
1024 x 768 @ 60Hz
1024 x 768 @ 70Hz
1024 x 768 @ 75Hz
1280 x 1024 @ 75Hz

(25h) Manufacturers Reserved Timings:
1152 x 870 @ 75Hz
800 x 600 @ 85Hz (N/A)
1024 x 768 @ 85Hz (N/A)
1280 x 1024 @ 60Hz (N/A)
1280 x 1024 @ 85Hz (N/A)
1600 x 1024 @ 60Hz (N/A)
1600 x 1200 @ 75Hz (N/A)
1600 x 1200 @ 85Hz (N/A)

(26~35h) Standard Timing Identification
1152 x 864 @ 60Hz 4: 3
1280 x 1024 @ 60Hz 5: 4
1280 x 960 @ 60Hz 4:3
1280 x 720 @ 60Hz 16:9
1400 x 1050@60Hz 4:3
1440 x 900@75Hz 16:10
No Application
No Application

(36~47h) Detailed Timing / Descriptor Block 1
1440x900 @ 60Hz 106.5 MHz

(5A~6Bh) Detailed Timing / Descriptor Block 2
Monitor Name: Philips 190EW

(48~59h) Detailed Timing / Descriptor Block 3
Min. Vertical Frequency: 56 Hz
Max. Vertical Frequency: 76 Hz
Min. Horizontal Frequency: 30 KHz
Max. Horizontal Frequency: 83 KHz
Max. Pixel Clock: 140 MHz

(6C~7Dh) Detailed Timing / Descriptor Block 4
Monitor Serial Number: Product provide

(7Eh) Extension flag 00

(7Fh) Checksum =OK

Safety instruction, warnings and notes

index of this chapter:

- 1 Safety Instructions
- 2 Warnings
- 3 Notes

1 Safety Instructions

Safety regulations require that during a repair:

- a. Connect the set to the AC Power via an isolation transformer (> 800 VA).
- b. Replace safety components, indicated by the symbol , only by components identical to the original ones. Any other component substitution (other than original type) may increase risk of fire or electrical shock hazard.

Safety regulations require that after a repair, the set must be returned in its original condition. Pay in particular attention to the following points:

- a. Route the wire trees correctly and fix them with the mounted cable clamps.
- b. Check the insulation of the AC Power lead for external damage.
- c. Check the strain relief of the AC Power cord for proper function.
- d. Check the electrical DC resistance between the AC Power plug and the secondary side (only for sets which have a AC Power isolated power supply):
 - * Unplug the AC Power cord and connect a wire between the two pins of the AC Power plug.
 - * Set the AC Power switch to the "on" position (keep the AC Power cord unplugged!).
 - * Measure the resistance value between the pins of the AC Power plug and the metal shielding of the tuner or the aerial connection on the set. The reading should be between 4.5 Mohm and 12 Mohm.
 - * Switch "off" the set, and remove the wire between the two Pins of the AC Power plug.
- e. Check the cabinet for defects, to avoid touching of any inner parts by the customer.

2 Warnings

- a. All ICs and many other semiconductors are susceptible to electrostatic discharges (ESD ) . Careless handling during repair can reduce life drastically. Make sure that, during repair, you are connected with the same potential as the mass of the set by a wristband with resistance. Keep components and tools also at this same potential.
- b. Be careful during measurements in the high voltage section.
- c. Never replace modules or other components while the unit is switched "on".
- d. When you align the set, use plastic rather than metal tools. This will prevent any short circuits and the danger of a circuit becoming unstable.

3 Notes

3.1 General

Measure the voltages and waveforms with regard to the chassis ground or hot ground, depending on the tested area of circuitry. The voltages and waveforms shown in the diagrams are indicative.

The semiconductors indicated in the circuit diagram and in the parts lists, are interchangeable per position with the semiconductors in the unit, irrespective of the type indication on

3.2 Schematic Notes

All resistor values are in ohms and the value multiplier is often used to indicate the decimal point location (e.g. 2K2 indicates 2.2 Kohm).

Resistor values with no multiplier may be indicated with either an "E" or an "R" (e.g. 220E or 220R indicates 220 ohm).

All capacitor values are given in micro-farads ($\times 10^{-6}$), nano-farads ($n = \times 10^{-9}$), or pico-farads ($p = \times 10^{-12}$).

Capacitor values may also use the value multiplier as the decimal point indication (e.g. 2p2 indicates 2.2 pF).

An "asterisk" (*) indicates component usage varies. Refer to the diversity tables for the correct values.

The correct component values are listed in the Electrical Replacement Parts List. Therefore, always check this list when there is any doubt.

3.3 Lead Free Solder

Philips CE is going to produce lead-free sets (PBF) from 1.1.2005 onwards.

Lead-free sets will be indicated by the PHILIPS-lead-free logo on the Printed Wiring Boards (PWB):



Figure 2-1 Lead-free logo

This sign normally has a diameter of 6 mm, but if there is less space on a board also 3 mm is possible.

In case of doubt whether the board is lead-free or not (or with mixed technologies), you can use the following method:

- * Always use the highest temperature to solder, when using SAC305 (see also instructions below).
- * De-solder thoroughly (clean solder joints to avoid mix of two alloys).

Caution: For BGA-ICs, you must use the correct temperature profile, which is coupled to the 12NC. For an overview of these profiles, visit the website <http://www.atyourservice.ce.philips.com/> You will find this and more technical information within the "Magazine", chapter "Workshop information".

For additional questions please contact your local repair desk. Due to lead-free technology some rules have to be respected by the workshop during a repair:

Use only lead-free soldering tin Philips SAC305 with order code 0622 149 00106. If lead-free solder paste is required, please contact the manufacturer of your soldering equipment. In general, use of solder paste within workshops should be avoided because paste is not easy to store and to handle.

Use only adequate solder tools applicable for lead-free soldering tin. The solder tool must be able

- To reach at least a solder-tip temperature of 400 degree C.
- To stabilise the adjusted temperature at the solder-tip.
- To exchange solder-tips for different applications.

Block Diagram

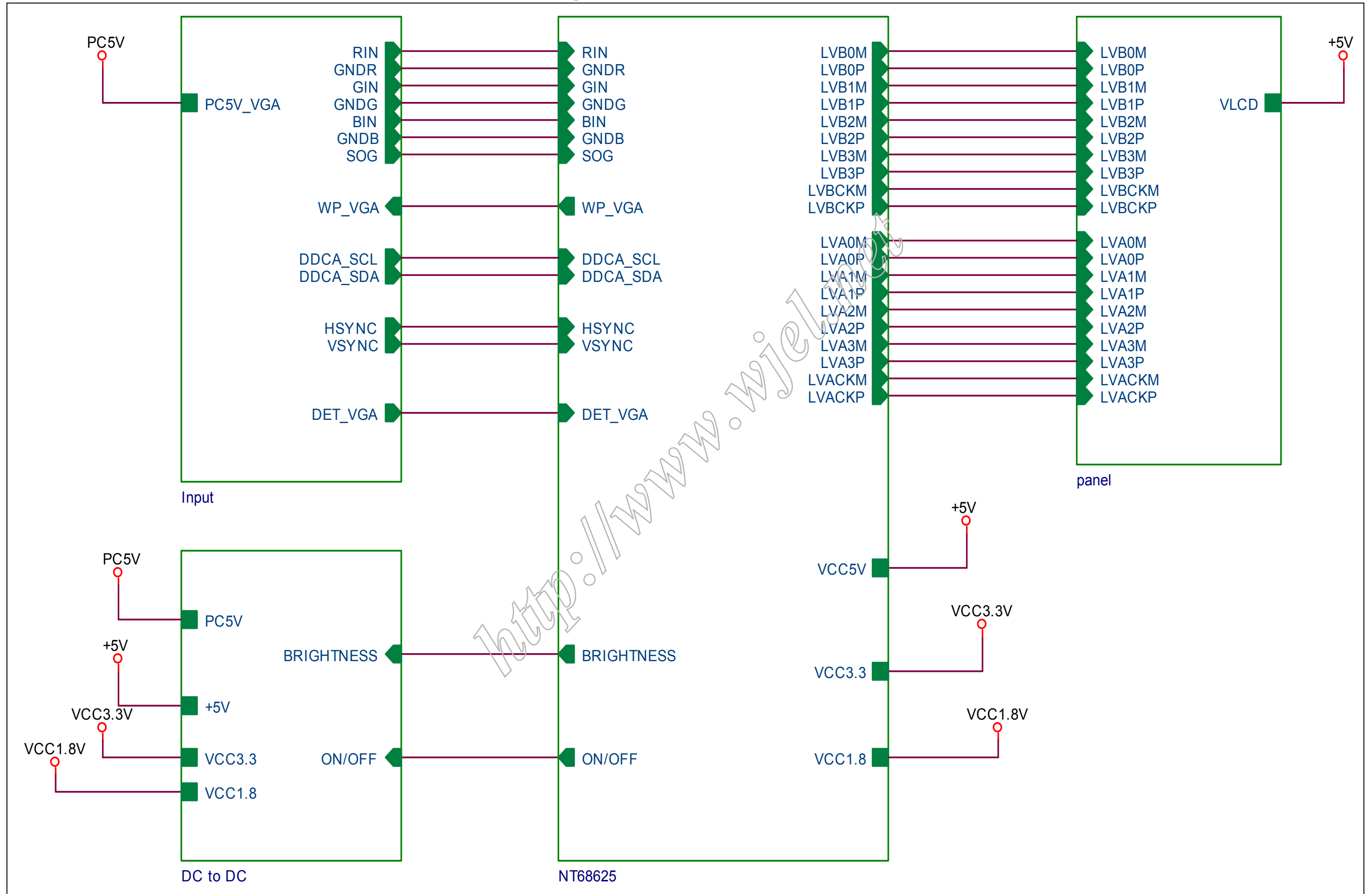

Schematic Diagram (Scaler Board - Power)

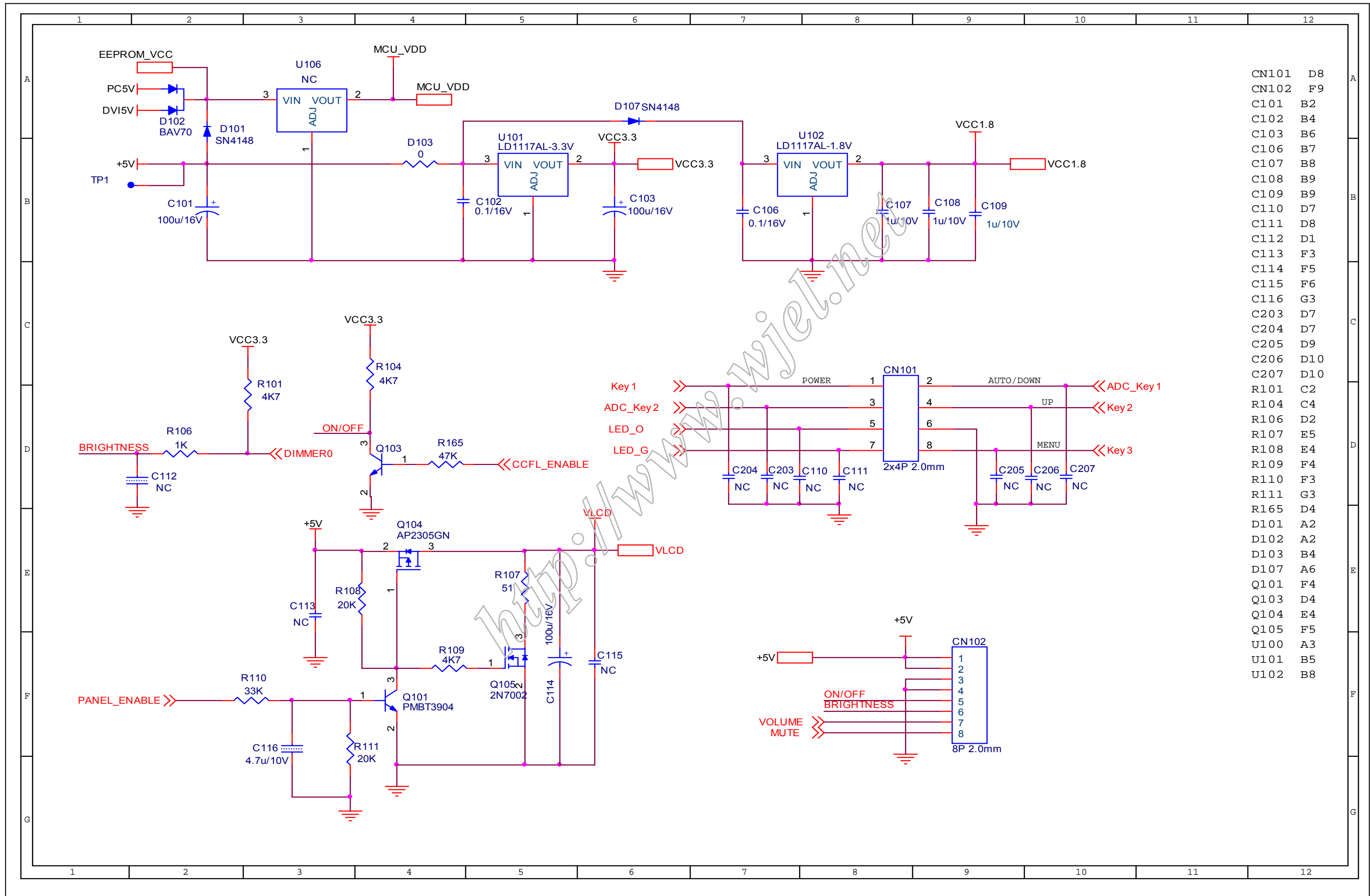

CN101	D8
CN102	F9
C101	B2
C102	B4
C103	B6
C106	B7
C107	B8
C108	B9
C109	B9
C110	D7
C111	D8
C112	D1
C113	F3
C114	F5
C115	F6
C116	G3
C203	D7
C204	D7
C205	D9
C206	D10
C207	D10
R101	C2
R104	C4
R106	D2
R107	E5
R108	E4
R109	F4
R110	F3
R111	G3
R165	D4
D101	A2
D102	A2
D103	B4
D107	A6
Q101	F4
Q103	D4
Q104	E4
Q105	F5
U100	A3
U101	B5
U102	B8

Schematic Diagram(Scaler Board –Input)

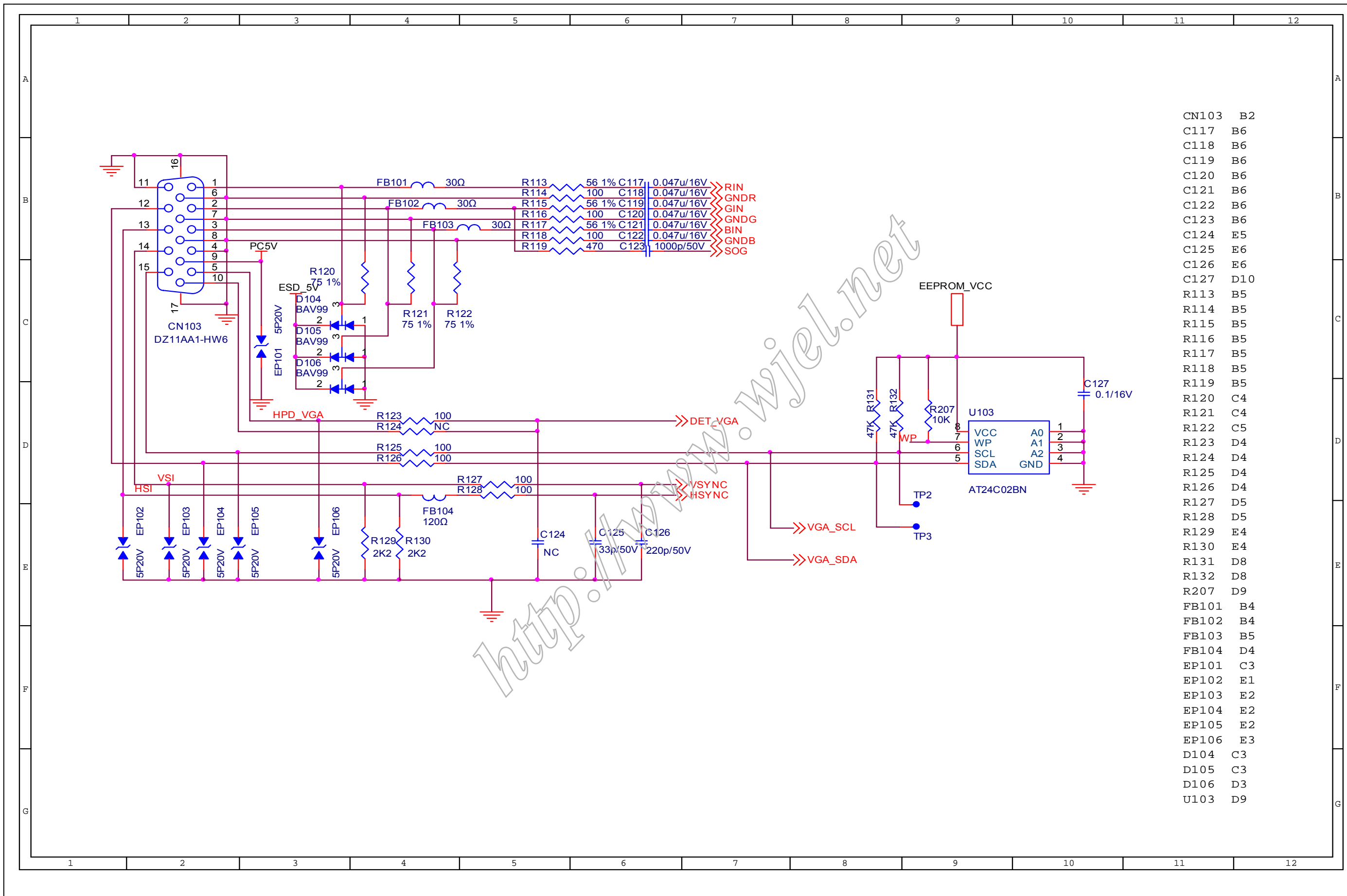

CN103	B2
C117	B6
C118	B6
C119	B6
C120	B6
C121	B6
C122	B6
C123	B6
C124	E5
C125	E6
C126	E6
C127	D10
R113	B5
R114	B5
R115	B5
R116	B5
R117	B5
R118	B5
R119	B5
R120	C4
R121	C4
R122	C5
R123	D4
R124	D4
R125	D4
R126	D4
R127	D5
R128	D5
R129	E4
R130	E4
R131	D8
R132	D8
R207	D9
FB101	B4
FB102	B4
FB103	B5
FB104	D4
EP101	C3
EP102	E1
EP103	E2
EP104	E2
EP105	E2
EP106	E3
D104	C3
D105	C3
D106	D3
U103	D9

Schematic Diagram(Scaler Board - Scaler)

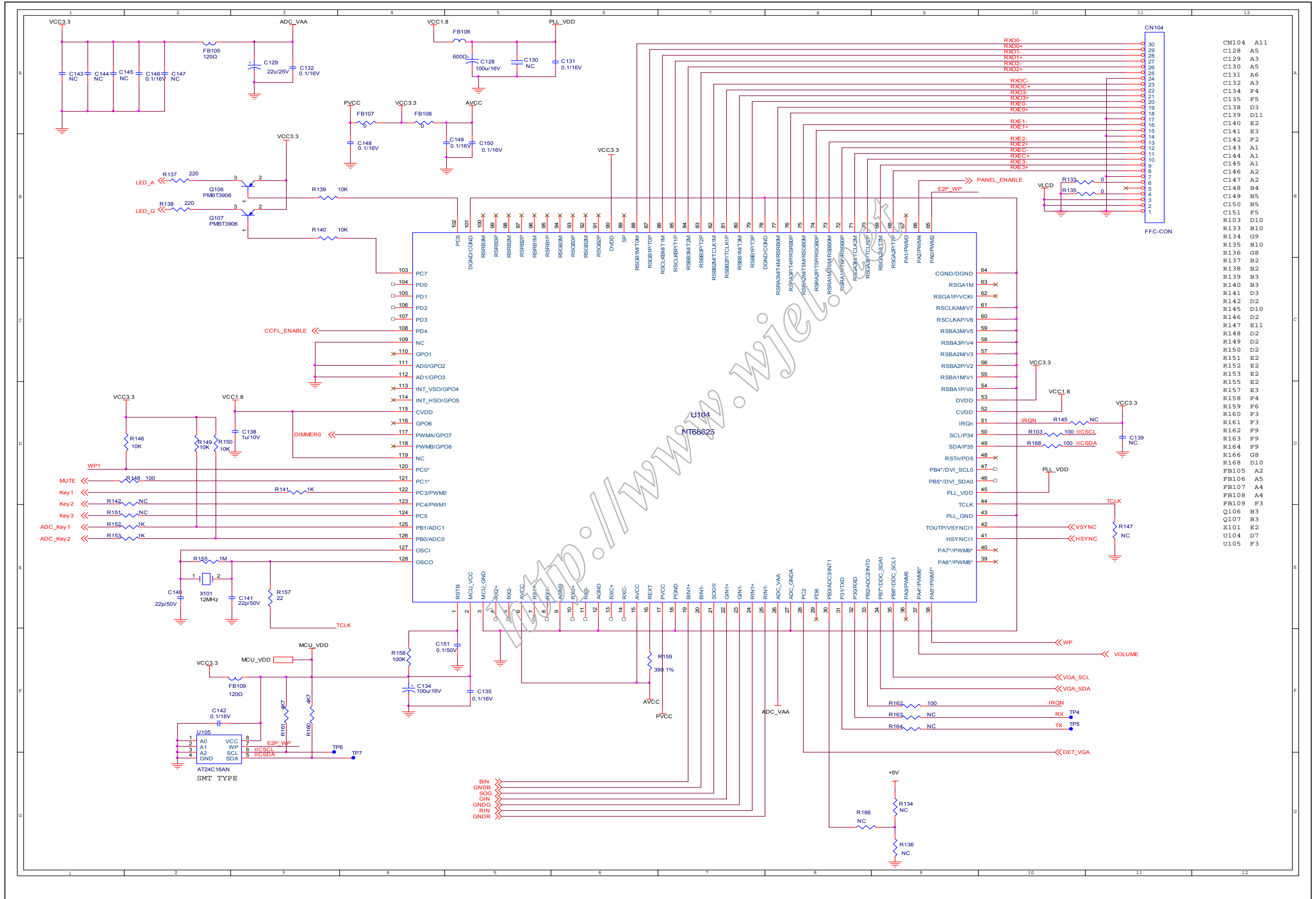

Schematic Diagram(Power Board)

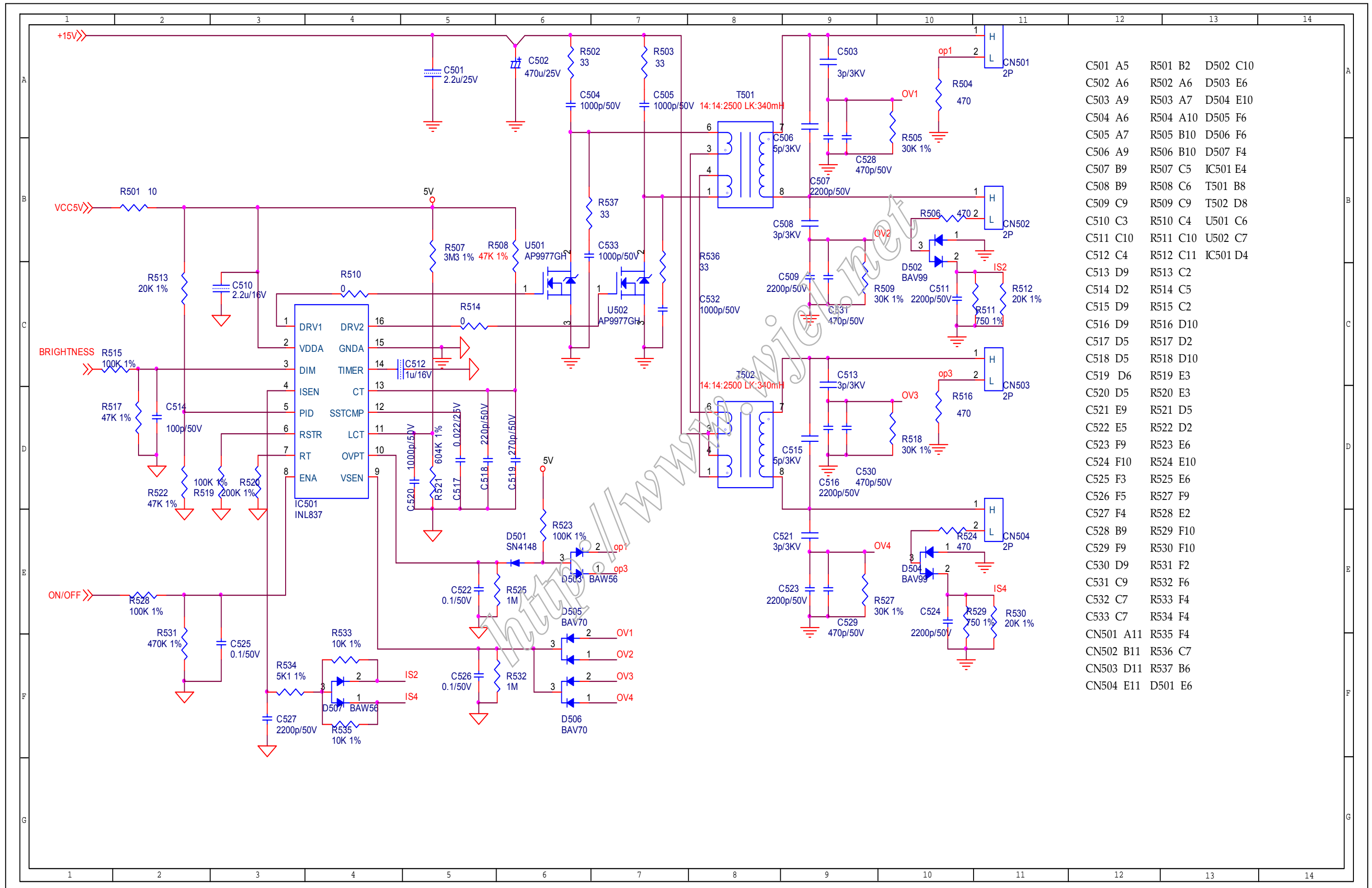

C501	A5	R501	B2	D502	C10
C502	A6	R502	A6	D503	E6
C503	A9	R503	A7	D504	E10
C504	A6	R504	A10	D505	F6
C505	A7	R505	B10	D506	F6
C506	A9	R506	B10	D507	F4
C507	B9	R507	C5	IC501	E4
C508	B9	R508	C6	T501	B8
C509	C9	R509	C9	T502	D8
C510	C3	R510	C4	U501	C6
C511	C10	R511	C10	U502	C7
C512	C4	R512	C11	IC501	D4
C513	D9	R513	C2		
C514	D2	R514	C5		
C515	D9	R515	C2		
C516	D9	R516	D10		
C517	D5	R517	D2		
C518	D5	R518	D10		
C519	D6	R519	E3		
C520	D5	R520	E3		
C521	E9	R521	D5		
C522	E5	R522	D2		
C523	F9	R523	E6		
C524	F10	R524	E10		
C525	F3	R525	E6		
C526	F5	R526	F9		
C527	F4	R527	E2		
C528	B9	R528	F10		
C529	F9	R529	F10		
C530	D9	R530	F2		
C531	C9	R531	F6		
C532	C7	R532	F4		
C533	C7	R533	F4		
CN501	A11	R535	F4		
CN502	B11	R536	C7		
CN503	D11	R537	B6		
CN504	E11	D501	E6		

Schematic Diagram(Power Board)

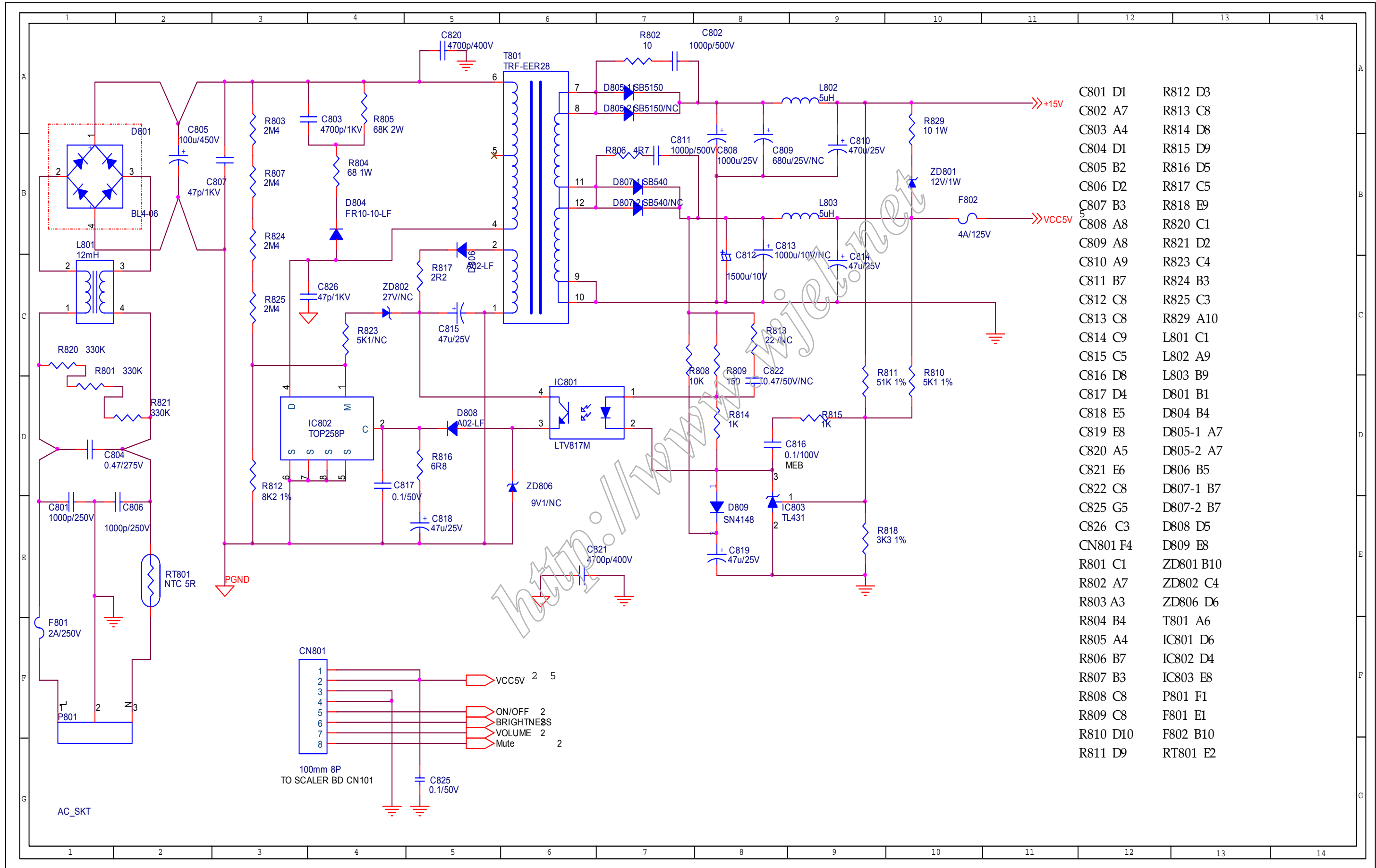

C801	D1	R812	D3
C802	A7	R813	C8
C803	A4	R814	D8
C804	D1	R815	D9
C805	B2	R816	D5
C806	D2	R817	C5
C807	B3	R818	E9
C808	A8	R820	C1
C809	A8	R821	D2
C810	A9	R823	C4
C811	B7	R824	B3
C812	C8	R825	C3
C813	C8	R829	A10
C814	C9	L801	C1
C815	C5	L802	A9
C816	D8	L803	B9
C817	D4	D801	B1
C818	E8	D804	B4
C819	E8	D805-1	A7
C820	A5	D805-2	A7
C821	E6	D806	B5
C822	C8	D807-1	B7
C825	G5	D807-2	B7
C826	C3	D808	D5
CN801	F4	D809	E8
R801	C1	ZD801	B10
R802	A7	ZD802	C4
R803	A3	ZD806	D6
R804	B4	T801	A6
R805	A4	IC801	D6
R806	B7	IC802	D4
R807	B3	IC803	E8
R808	C8	P801	F1
R809	C8	F801	E1
R810	D10	F802	B10
R811	D9	RT801	E2

Schematic Diagram(Button Board)

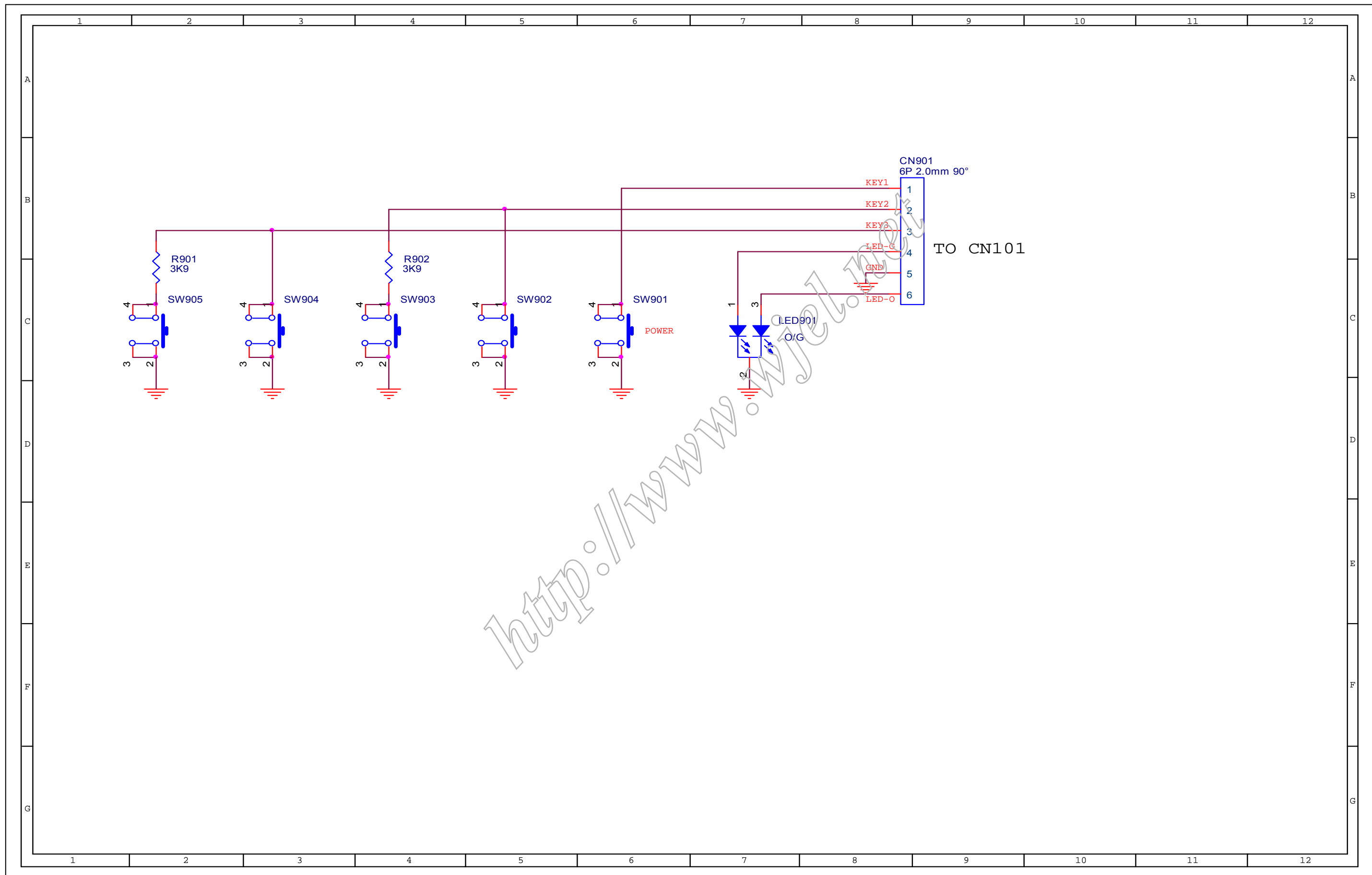

Layout side View(Scaler Board)

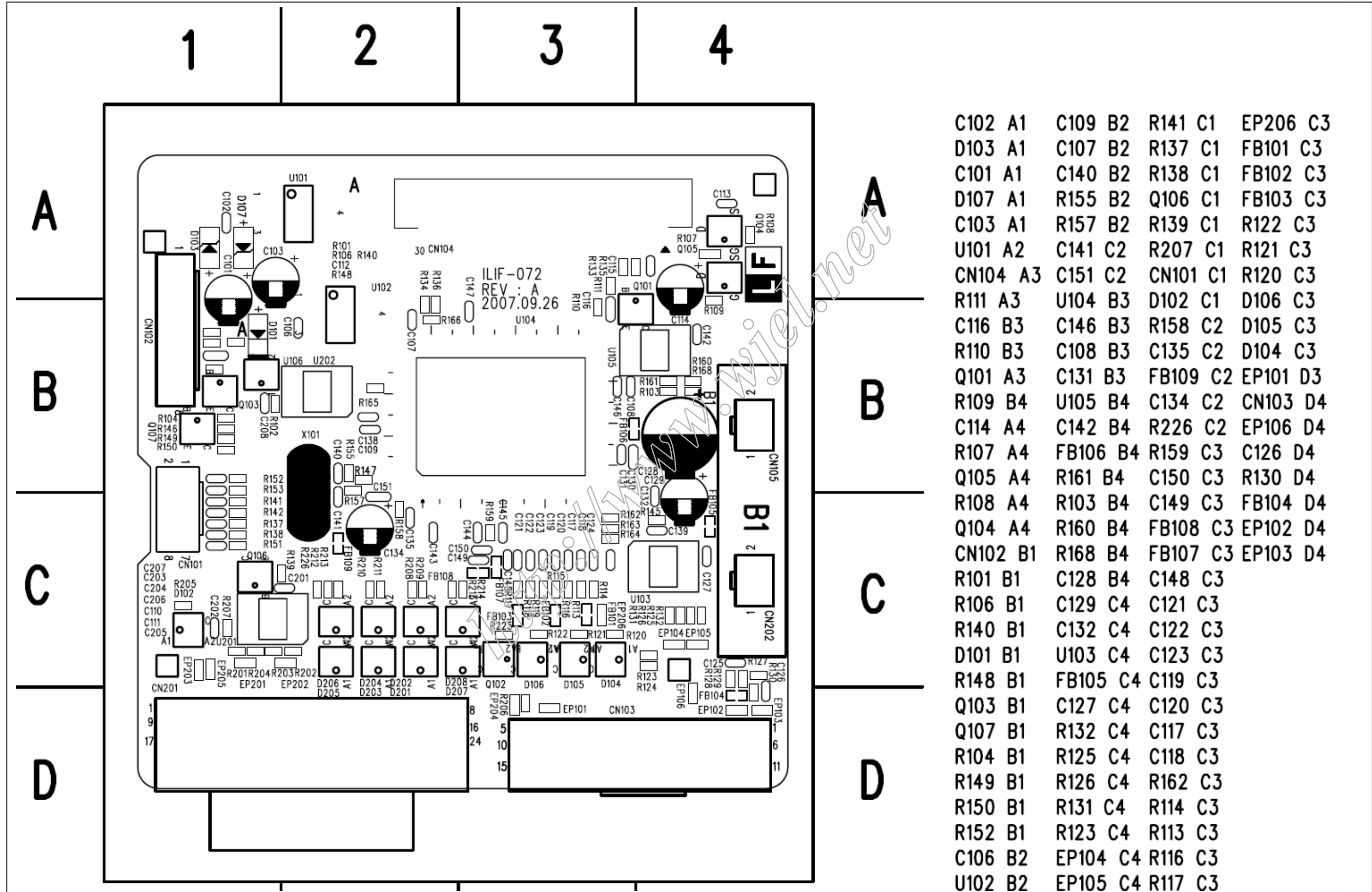

Layout side View(Power Board)

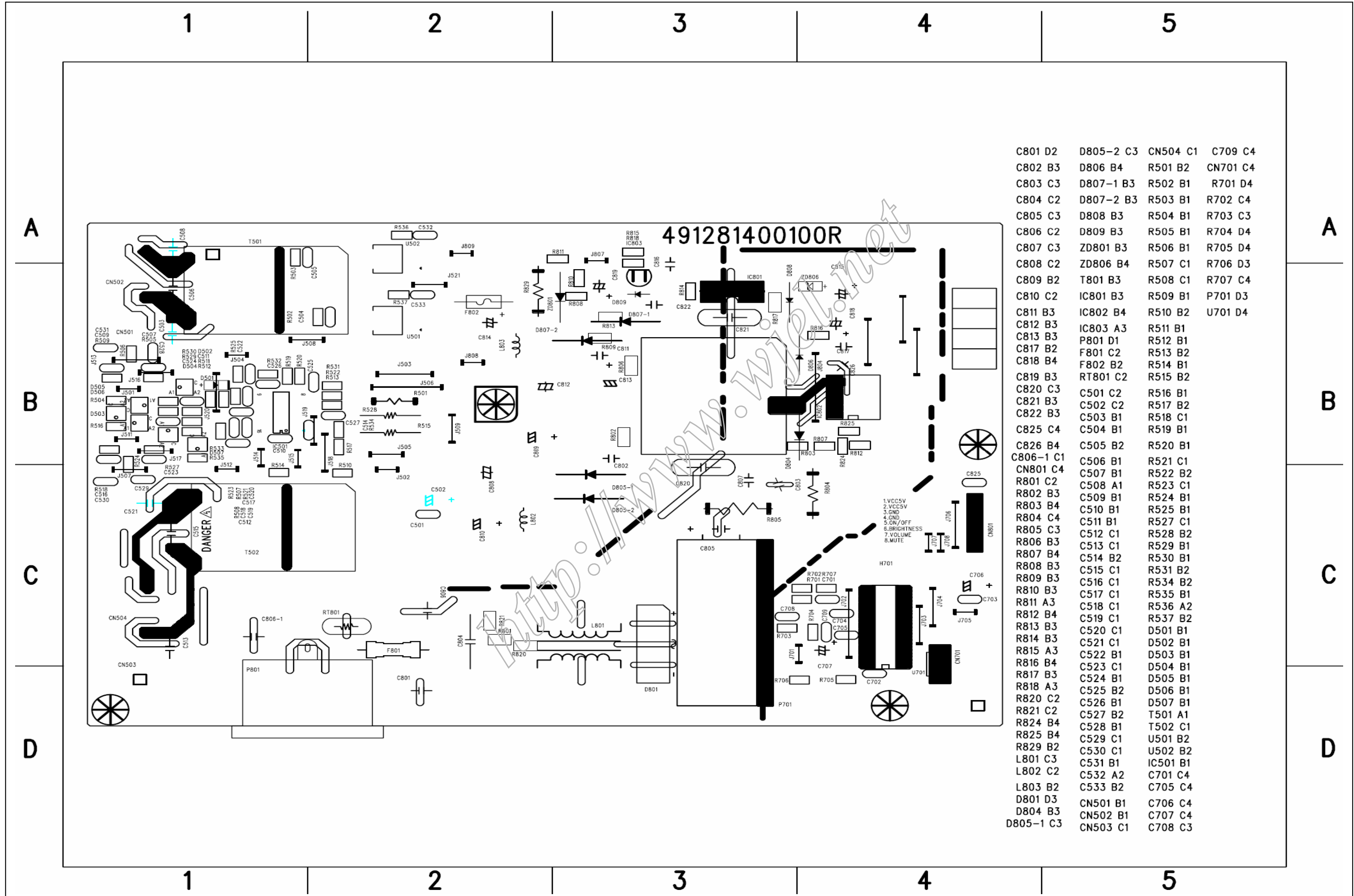

C801 D2	D805-2 C3	CN504 C1	C709 C4
C802 B3	D806 B4	R501 B2	CN701 C4
C803 C3	D807-1 B3	R502 B1	R701 D4
C804 C2	D807-2 B3	R503 B1	R702 C4
C805 C3	D808 B3	R504 B1	R703 C3
C806 C2	D809 B3	R505 B1	R704 D4
C807 C3	ZD801 B3	R506 B1	R705 D4
C808 C2	ZD806 B4	R507 C1	R706 D3
C809 B2	T801 B3	R508 C1	R707 C4
C810 C2	IC801 B3	R509 B1	P701 D3
C811 B3	IC802 B4	R510 B2	U701 D4
C812 B3	IC803 A3	R511 B1	
C813 B3	P801 D1	R512 B1	
C817 B2	F801 C2	R513 B2	
C818 B4	F802 B2	R514 B1	
C819 B3	RT801 C2	R515 B2	
C820 C3	C501 C2	R516 B1	
C821 B3	C502 C2	R517 B2	
C822 B3	C503 B1	R518 C1	
C825 C4	C504 B1	R519 B1	
C826 B4	C505 B2	R520 B1	
C806-1 C1	C506 B1	R521 C1	
CN801 C4	C507 B1	R522 B2	
R801 C2	C508 A1	R523 C1	
R802 B3	C509 B1	R524 B1	
R803 B4	C510 B1	R525 B1	
R804 C4	C511 B1	R527 C1	
R805 C3	C512 C1	R528 B2	
R806 B3	C513 C1	R529 B1	
R807 B4	C514 B2	R530 B1	
R808 B3	C515 C1	R531 B2	
R809 B3	C516 C1	R534 B2	
R810 B3	C517 C1	R535 B1	
R811 A3	C518 C1	R536 A2	
R812 B4	C519 C1	R537 B2	
R813 B3	C520 C1	D501 B1	
R814 B3	C521 C1	D502 B1	
R815 A3	C522 B1	D503 B1	
R816 B4	C523 C1	D504 B1	
R817 B3	C524 B1	D505 B1	
R818 A3	C525 B2	D506 B1	
R820 C2	C526 B1	D507 B1	
R821 C2	C527 B2	T501 A1	
R824 B4	C528 B1	T502 C1	
R825 B4	C529 C1	U501 B2	
R829 B2	C530 C1	U502 B2	
L801 C3	C531 B1	IC501 B1	
L802 C2	C532 A2	C701 C4	
L803 B2	C533 B2	C705 C4	
D801 D3	CN501 B1	C706 C4	
D804 B3	CN502 B1	C707 C4	
D805-1 C3	CN503 C1	C708 C3	

Exploded View

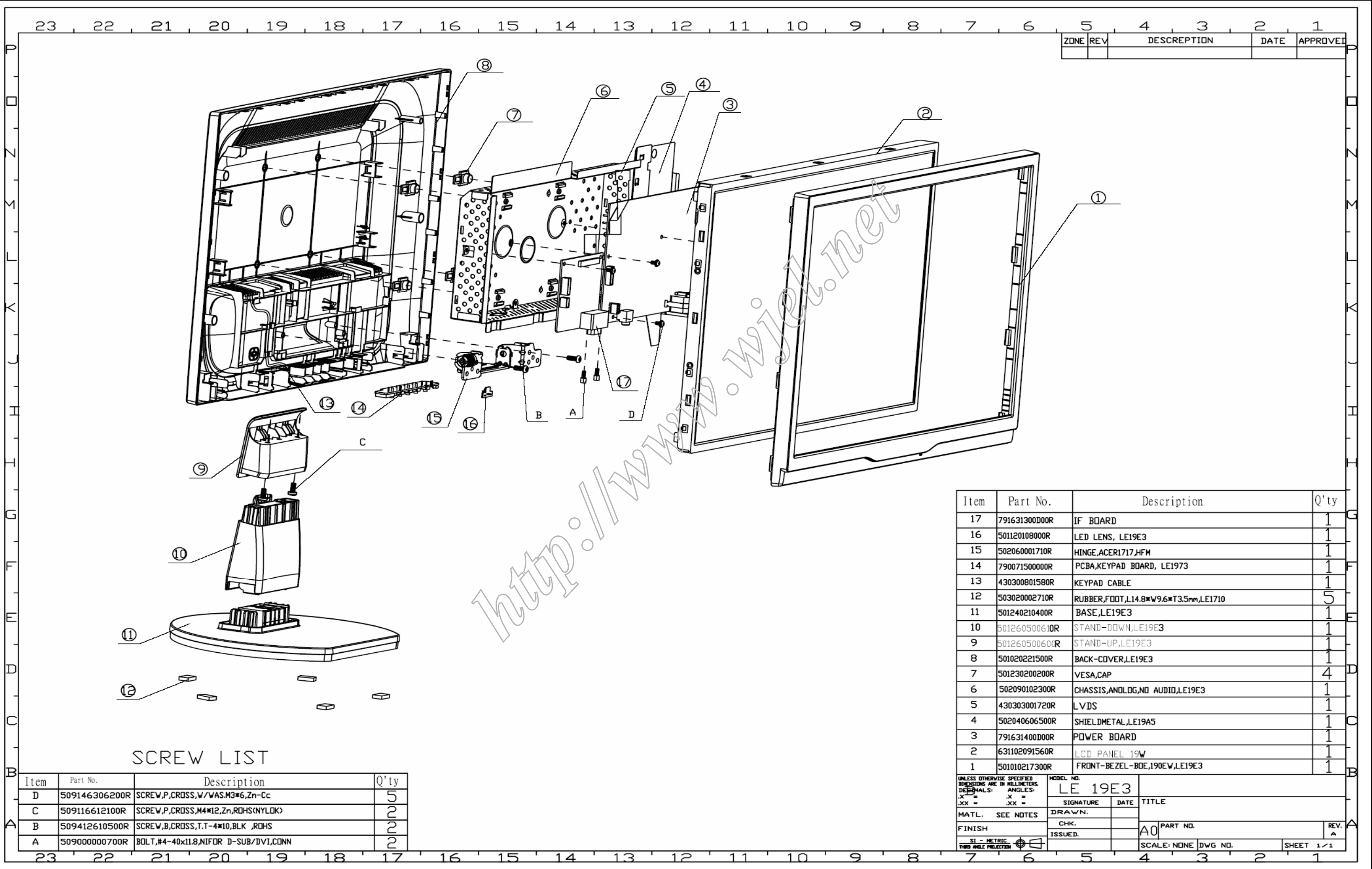

Item	Part No.	Description	Q'ty
17	791631300D00R	IF BOARD	1
16	501120108000R	LED LENS, LE19E3	1
15	502060001710R	HINGE,ACER1717,HFM	1
14	790071500000R	PCBA,KEYPAD BOARD, LE1973	1
13	430300801580R	KEYPAD CABLE	1
12	503020002710R	RUBBER,FOOT,L14.8*W9.6*H3.5mm,LE1710	5
11	501240210400R	BASE,LE19E3	1
10	501260500610R	STAND-DOWN,LE19E3	1
9	501260500600R	STAND-UP,LE19E3	1
8	501020221500R	BACK-COVER,LE19E3	1
7	501230200200R	VESA,CAP	4
6	502090102300R	CHASSIS,ANDLOG,NO AUDIO,LE19E3	1
5	430303001720R	LVDS	1
4	502040606500R	SHIELDMETAL,LE19A5	1
3	791631400D00R	POWER BOARD	1
2	631102091560R	LCD PANEL 19W	1
1	501010217300R	FRONT-BEZEL-BOE,190EW,LE19E3	1

SCREW LIST

Item	Part No.	Description	Q'ty
D	509146306200R	SCREW,P,CROSS,W/WAS,M3*6,Zn-Cc	5
C	509116612100R	SCREW,P,CROSS,M4*12,Zn,ROHS(NYLDK)	2
B	509412610500R	SCREW,B,CROSS,T.T-4*10,BLK ,ROHS	2
A	50900000700R	BOLT,#4-40x11.8,NIFOR D-SUB/DVI,CONN	2

UNLESS OTHERWISE SPECIFIED DIMENSIONS ARE IN MILLIMETERS.		MODEL NO.	
DECIMALS: X =	ANGLES: X =	LE 19E3	
.XX = .XX =		SIGNATURE	DATE
MATERIAL: SEE NOTES		TITLE	
FINISH		CHK.	
		ISSUED.	
SI - METRIC THIRD ANGLE PROJECTION		PART NO. A0	
		SCALE: NONE	DWG NO.
		SHEET 1/1	

Recommended Spare Part List

RSPL FOR 190EW9FB/93

1 P/N: 8191E3D1W060R(BOE panel)

	Part Name	PHILIPS P/N	PCM CODE	Description	Q'ty	Location	Location	Remark
Electronic Components:	LCD panel	996510017294	631102091560R	PANEL 190WG1-600-5241(A)(BOE)	1	Item 2 in exploded view	E2	BOE PANEL
	LCD panel	996510017295	631102091570R	PANEL 190WG1-600-5941(A)(BOE)	1	Item 2 in exploded view	E2	BOE PANEL
	MB-LCD cable	996510017304	430303001720R	HRN LVDS FFC 30P 197mm	1	Item 5 in exploded view	E5	
	IC	996510017159	412000435481R	AT24C02BN-SH-T	1	U103,	U103	ATMEL,
	IC	996510017297	412000624952R	IC NT68625HMFG-128/J	1	U104,	U104	NOVATEK,
	IC	996510017161	412000224482R	AT24C16BN-SH-T 16K	1	U105,	U105	ATMEL,
	TRANSISTOR	996510017300	426000090991R	Transf EEL19 P4 DIP SPW-099	2	T501,T502,	T501	DARFON,FOXCONN,FRONTIER,LISHIN,
	TRANSISTOR	996510017301	426000090900R	Transf ER28 PC40 DIP SPW-090	1	T801,	T801	FOXCONN,FRONTIER,LISHIN,NCE,
Mechanical Components :	STAND	996510017291	501260500610R	DOWN STAND	1	Item 10 in exploded view	E10	
	BASE	996510017292	714020014100R	BASE assembly	1	Item 11 ,12 in exploded view	E1112	
	Hinge		502060001710R	HINGE	1	Item 15 in exploded view	E15	
	DVI&D-SUB to shielding		509000000700R	BOLT,#4-40x11.8,Ni	2	Item A in exploded view	EA	
	PCBAs to metal shielding		509146306102R	SCREW,P,CROSS W/W-SPR,M3*6,Zn	5	Item D in exploded view	ED	
PCBA:	Interface board	996510017296	791631300D00R	INTERFACE BOARD PCBA	1	Item 17 in exploded view	E17	
	Power board	996510017298	791631400D00R	POWER BOARD PCBA	1	Item 3 in exploded view	E3	
	Button board	996510017303	790071500000R	SWITCH BOARD PCBA	1	Item 13 in exploded view	E4	
Cabinets:	Front bezel	996510017290	714030017101R	FRONT BEZELassembly	1	Item 1 in exploded view	34	
	Back cover	996510017293	714050016000R	BACK-COVER assembly	1	Item 8,9 in exploded view	E89	
Accessories:	VGA CABLE	996510017138	453010100310R	CABLE D-SUB BLACK/BLUE ROH	1		20	
	POWER CORD	996510017139	453070800170R	PWRCORD 10A/250V BLK	1		21	
	Manual	996510017287	703500005801R	ACCESSORY assembly	1		29	
Packing Material:	EpE bag	996510017283	506120002510R	PE BAG FOR BASE	1		25	
	EpE bag	996510017284	506120003600R	PE BAG	1		26	
	EpE bag	996510017285	506120302200R	EPE+PE BAG	1		27	
	Carton	996510017286	506020024100R	CARTON	1		28	
	Cusion	996510017291	506060010000R	CUSHION,EPS-RIGHT	1		23	
	Cusion	996510017282	506060010010R	CUSHION,EPS-LEFT	1		24	

Recommended Spare Part List

RSPL FOR 190EW9FB/00

1 P/N: 8191E3D1W020R(BOE panel)

	Part Name	PHILIPS P/N	PCM CODE	Description	Qty	Location	Location	Remark
Electronic Components:	LCD panel	996510017294	631102091560R	PANEL 190WG1-600-5241(A)(BOE)	1	Item 2 in exploded view	E2	BOE PANEL
	LCD panel	996510017295	631102091570R	PANEL 190WG1-600-5941(A)(BOE)	1	Item 2 in exploded view	E2	BOE PANEL
	MB-LCD cable	996510017304	430303001720R	HRN LVDS FFC 30P 197mm	1	Item 5 in exploded view	E5	
	IC	996510017159	412000435481R	AT24C02BN-SH-T	1	U103,	U103	ATMEL,
	IC	996510017297	412000624952R	IC NT68625HMFG-128/J	1	U104,	U104	NOVATEK,
	IC	996510017161	412000224482R	AT24C16BN-SH-T 16K	1	U105,	U105	ATMEL,
	TRANSISTOR	996510017300	426000090991R	Transf EEL19 P4 DIP SPW-099	2	T501,T502,	T501	DARFON,FOXCONN,FRONTIER,LISHIN,
	TRANSISTOR	996510017301	426000090900R	Transf ER28 PC40 DIP SPW-090	1	T801,	T801	FOXCONN,FRONTIER,LISHIN,NCE,
Mechanical Components :	STAND	996510017291	501260500610R	DOWN STAND	1	Item 10 in exploded view	E10	
	BASE	996510017292	714020014100R	BASE assembly	1	Item 11 ,12 in exploded view	E11,12	
	Hinge		502060001710R	HINGE	1	Item 15 in exploded view	E15	
	DVI&D-SUB to shielding		509000000700R	BOLT,#4-40x11.8,Ni	2	Item A in exploded view	EA	
	PCBAs to metal shielding		509146306102R	SCREW,P,CROSS W/W-SPR,M3*6,Zn	5	Item D in exploded view	ED	
PCBA:	Interface board	996510017296	791631300D00R	INTERFACE BOARD PCBA	1	Item 17 in exploded view	E17	
	Power board	996510017298	791631400D00R	POWER BOARD PCBA	1	Item 3 in exploded view	E3	
	Button board	996510017303	790071500000R	SWITCH BOARD PCBA	1	Item 13 in exploded view	E4	
Cabinets:	Front bezel	996510017290	714030017101R	FRONT BEZEL assembly	1	Item 1 in exploded view	34	
	Back cover	996510017293	714050016000R	BACK-COVER assembly	1	Item 8,9 in exploded view	E89	
Accessories:	VGA CABLE	996510017138	453010100310R	CABLE D-SUB BLACK/BLUE ROH	1		20	
	POWER CORD		453070800210R	PWRCORD 16A/250V, BLK 6FT VDE	1		22	
Packing Material:	EpE bag	996510017283	506120002510R	PE BAG FOR BASE	1		25	
	EpE bag	996510017284	506120003600R	PE BAG	1		26	
	EpE bag	996510017285	506120302200R	EPE+PE BAG	1		27	
	Carton	996510017286	506020024101R	CARTON	1		28	
	Cusion	996510017281	506060010000R	CUSHION EPS-RIGHT	1		23	
	Cusion	996510017282	506060010010R	CUSHION EPS-LEFT	1		24	

RSPL FOR 190EW9FB/05

1 P/N: 8191E3D1W050R(BOE panel)

	Part Name	PHILIPS P/N	PCM CODE	Description	Q'ty	Location	Location	Remark
Electronic Components:	LCD panel	996510017294	631102091560R	PANEL 190WG1-600-5241(A)(BOE)	1	Item 2 in exploded view	E2	BOE PANEL
	LCD panel	996510017295	631102091570R	PANEL 190WG1-600-5941(A)(BOE)	1	Item 2 in exploded view	E2	BOE PANEL
	MB-LCD cable	996510017304	430303001720R	HRN LVDS FFC 30P 197mm	1	Item 5 in exploded view	E5	
	IC	996510017159	412000435481R	AT24C02BN-SH-T	1	U103,	U103	ATMEL,
	IC	996510017297	412000624952R	IC NT68625HMFG-128/J	1	U104,	U104	NOVATEK,
	IC	996510017161	412000224482R	AT24C16BN-SH-T 16K	1	U105,	U105	ATMEL,
	TRANSISTOR	996510017300	426000090991R	Transf EEL19 P4 DIP SPW-099	2	T501,T502,	T501	DARFON,FOXCONN,FRONTIER, LISHIN,
	TRANSISTOR	996510017301	426000090900R	Transf ER28 PC40 DIP SPW-090	1	T801,	T801	FOXCONN,FRONTIER,LISHIN,NCE,
Mechanical Components:	STAND	996510017291	501260500610R	DOWN STAND	1	Item 10 in exploded view	E10	
	BASE	996510017292	714020014100R	BASE assembly	1	Item 11 ,12 in exploded view	E11,12	
	Hinge		502060001710R	HINGE	1	Item 15 in exploded view	E15	
	DVI&D-SUB to shielding		509000000700R	BOLT,#4-40x11.8,Ni	2	Item A in exploded view	EA	
	PCBAs to metal shielding		509146306102R	SCREW,P,CROSS W/W-SPR,M3*6,Zn	5	Item D in exploded view	ED	
PCBA:	Interface board	996510017296	791631300D00R	INTERFACE BOARD PCBA	1	Item 17 in exploded view	E17	
	Power board	996510017298	791631400D00R	POWER BOARD PCBA	1	Item 3 in exploded view	E3	
	Button board	996510017303	790071500000R	SWITCH BOARD PCBA	1	Item 13 in exploded view	E4	
Cabinets:	Front bezel	996510017290	714030017100R	Cabinet assembly	1	Item 1 in exploded view	34	
	Back cover	996510017293	714050016000R	BACK-COVER assembly	1	Item 8,9 in exploded view	E89	
Accessories:	VGA CABLE	996510017138	453010100310R	CABLE D-SUB BLACK/BLUE ROH	1		20	
	POWER CORD		453070800230R	PWRCORD 5A/250V BLK	1		21	
	Manual		703500005800R	ACCESSORY assembly	1		29	
Packing Material:	EpE bag	996510017283	506120002510R	PE BAG FOR BASE	1		25	
	EpE bag	996510017284	506120003600R	PE BAG	1		26	
	EpE bag	996510017285	506120302200R	EPE+PE BAG	1		27	
	Carton		506020024101R	CARTON	1		28	
	Cusion	996510017281	506060010000R	CUSHION,EPS-RIGHT	1		23	
	Cusion	996510017282	506060010010R	CUSHION,EPS-LEFT	1		24	

RSPL FOR 190EW9FB/62
P/N :8191E3D1W021R (BOE panel)

	Part Name	PHILIPS P/N	PCM CODE	Description	Q'ty	Location	Location	Remark
Electronic Components:	LCD panel	996510017294	631102091560R	PANEL 190WG1-600-5241(A)(BOE)	1	Item 2 in exploded view	E2	BOE PANEL
	LCD panel	996510017295	631102091570R	PANEL 190WG1-600-5941(A)(BOE)	1	Item 2 in exploded view	E2	BOE PANEL
	MB-LCD cable	996510017304	430303001720R	HRN LVDS FFC 30P 197mm	1	Item 5 in exploded view	E5	
	IC	996510017159	412000435481R	AT24C02BN-SH-T	1	U103,	U103	ATMEL,
	IC	996510017297	412000624952R	IC NT68625HMF-G-128/J	1	U104,	U104	NOVATEK,
	IC	996510017161	412000224482R	AT24C16BN-SH-T 16K	1	U105,	U105	ATMEL,
	TRANSISTOR	996510017300	426000090991R	Transf EEL19 P4 DIP SPW-099	2	T501,T502,	T501	DARFON,FOXCONN,FRONTIER, LISHIN,
	TRANSISTOR	996510017301	426000090900R	Transf ER28 PC40 DIP SPW-090	1	T801,	T801	FOXCONN,FRONTIER, LISHIN,NCE,
Mechanical Components :	STAND	996510017291	501260500610R	DOWN STAND	1	Item 10 in exploded view	E10	
	BASE	996510017292	714020014100R	BASE assembly	1	Item 11 ,12 in exploded view	E11,12	
	Hinge		502060001710R	HINGE	1	Item 15 in exploded view	E15	
	DVI&D-SUB to shielding		509000000700R	BOLT #4-40x11.8,Ni	2	Item A in exploded view	EA	
	PCBAs to metal shielding		509146306102R	SCREW,P,CROSS W/W-SPR,M3*6,Zn	5	Item D in exploded view	ED	
PCBA:	Interface board	996510017296	791631300D00R	INTERFACE BOARD PCBA	1	Item 17 in exploded view	E17	
	Power board	996510017298	791631400D00R	POWER BOARD PCBA	1	Item 8 in exploded view	E3	
	Button board	996510017303	790071500000R	SWITCH BOARD PCBA	1	Item 13 in exploded view	E4	
Cabinets:	Front bezel	996510017290	714030017101R	FRONT BEZEL assembly	1	Item 1 in exploded view	34	
	Back cover	996510017293	714050016000R	BACK-COVER assembly	1	Item 8,9 in exploded view	E89	
Accessories:	VGA CABLE	996510017138	453010100310R	CABLE D-SUB BLACK/BLUE,ROH	1		20	
	POWER CORD		453070800210R	PWRCORD 16A/250V,BLK 6FT VDE	1		22	
Packing Material:	EpE bag	996510017283	506120002510R	PE BAG FOR BASE	1		25	
	EpE bag	996510017284	506120003600R	PE BAG	1		26	
	EpE bag	996510017285	506120302200R	EPET PE BAG	1		27	
	Carton	996510017286	506020024101R	CARTON	1		28	
	Cusion	996510017281	506060010000R	CUSHION EPS-RIGHT	1		23	
	Cusion	996510017282	506060010010R	CUSHION EPS-LEFT	1		24	

Note:

(1). U104 is NOVATEK68625H IC. The NOVATEK68625H contains MCU and scalar. MCU contains a flash memory to store the firmware code and also responsible for the system processing.

There are A/D converter, scaling, OSD, LVDS transmitting system in NOVATEK68625H. It also supports detecting modes and VESA DPMS control.

(2). U105 is an EEPROM. We use it store the color temperature data, monitor user data, mode index, system set data, elapsed data and user preset timings, OSD function data and user preset timings ...

(3). U103 is an EEPROM. It stores VGA EDID.

(4). When you buy new U104, U105, U103, they are empty. There is no data inside. You must load firmware code in U105 and load VGA EDID in U103.

You don't load any data in U104, when use the monitor it will store elapsed data, user preset timings, OSD function data, user preset timings... ..

19 inch monitor different parts list

19 inch monitor different parts list				190EW9FB/93(LE19E3-D10)	190EW9FB/00(LE19E3-D10)	190EW9FB/05(LE19E3-D10)	190EW9FB/62(LE19E3-D10)
Item	Part Number	Part Description	2nd source				
1	453070800170R	PWRCORD 10A/250V BLK 6FT CHINA.RVV 3Gx0.		v			
	453070800210R	PWR CORD 16A/250V BLK 6FT VDE H05VV-F 3G			v		v
	453070800230R	PWRCORD 5A/250V BLK 6FT UK3Gx.75mm(SP60)				v	
2	501010217300R	FRONT-BEZEL-BOE,190EW,LE19E3			v	v	v
	501010217301R	FRONT-BEZEL-BOE,190EW9 ,LE19E3		v			
3	506020024100R	CARTON,PHILIPS,LE19E3		v			
	506020024101R	CARTON,PHILIPS-EU,LE19E3			v	v	V
4	506092007200R	CARD,WARRANTY,PHILIPS-PRC,LE19E3		v			
	506092007201R	CARD,WARRANTY,PHILIPS-TUR,LE19E3					v
	506092007202R	CARD,SERVICE,PHILIPS-TUR,LE19E3					v
	506092007203R	CARD,QSG,PHILIPS-TUR,LE19E3					v
5	506380002400R	TAPE,WRAPPING TYPE,76mmx1000M, LE1729		v			
	506380003710R	TAPE,WRAPPING TYPE,76mmx1096M, LE19E3			v	v	V
6	506380003200R	TAPE,ACE,36mmx30000mm (PC=36x20mm)LE1915		v	v	v	
7	506390000500R	LABEL,OC-PASS, LE1709		v			
	506390500200R	LABEL,ENERGY STAR, LE1720/LE1920					v
8	506390301501R	FEATURE LABEL-PRC,LE19E3		v			
9	501230200100R	VESA,CAP,LE1973,ROHS					v
	501230200200R	VESA-CAP		v	v	v	
10	703500005800R	KIT,ACCESSORY,PHILIPS-EU,LE19E3			v	v	
	703500005801R	KIT,ACCESSORY,PHILIPS-PRC,LE19E3		v			
11	713100004200R	ASSY,PACKAGE,PACK,PHILIPS-EU,LE19E3			v	v	
	713100004201R	ASSY,PACKAGE,PACK,PHILIPS-PRC,LE19E3		v			
	713100004202R	ASSY,PACKAGE,PACK,PHILIPS-TUR,LE19E3					v
12	714030017100R	ASSY,FRONT BEZEL,190EW , LE19E3			v	v	V
	714030017101R	ASSY,FRONT BEZEL,190EW9 , LE19E3		v			
13	7140738D0000R	ASSY,FINAL(B+S)W/O SPK,LE19E3-D10(Philip		v			
	7140738D0001R	ASSY,FINAL(B+S)W/OSP,LE19E3-D10(Philips			v	v	V

General Trouble Shooting Guide

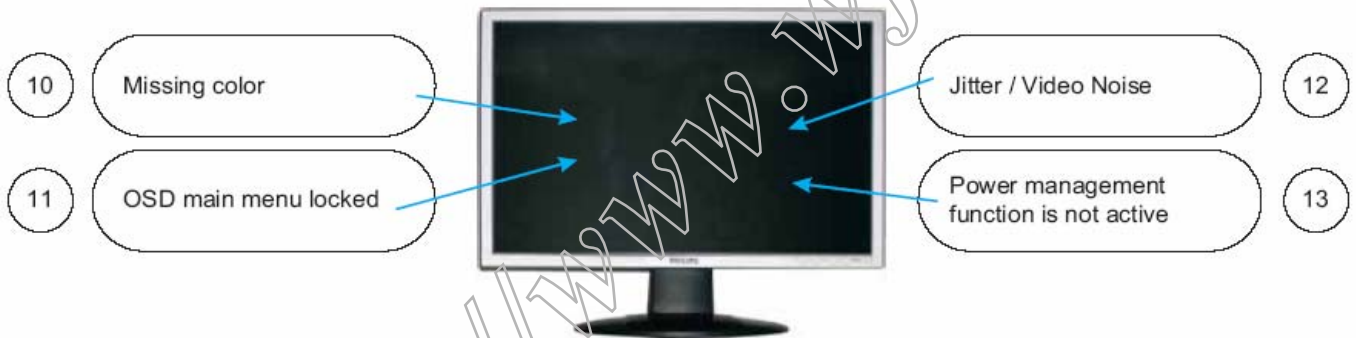
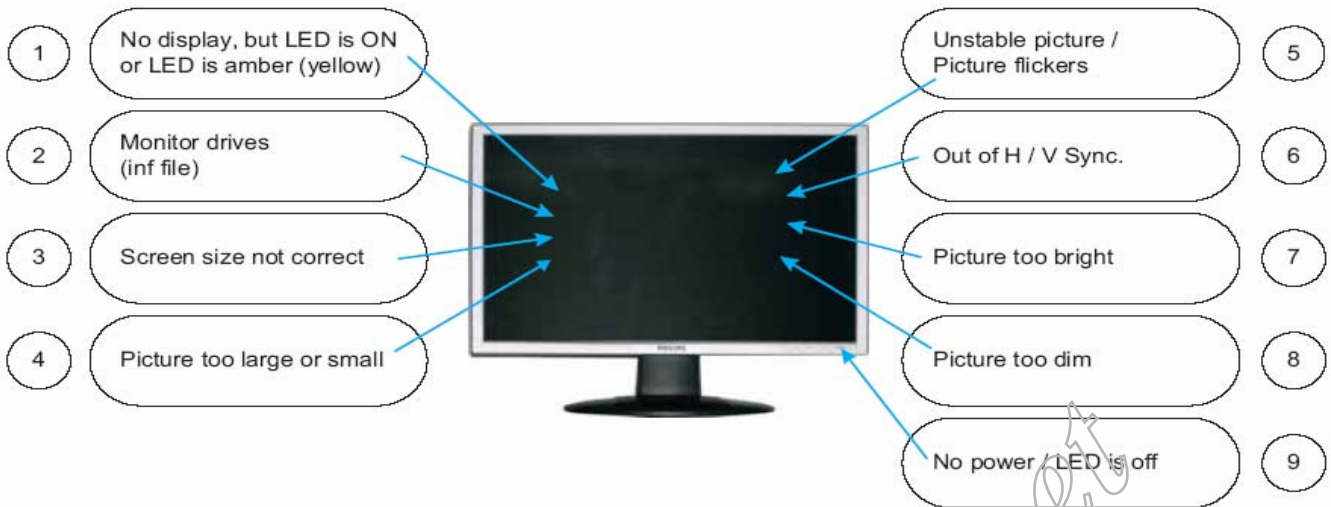

<http://www.wjel.net>

General Trouble Shooting Guide

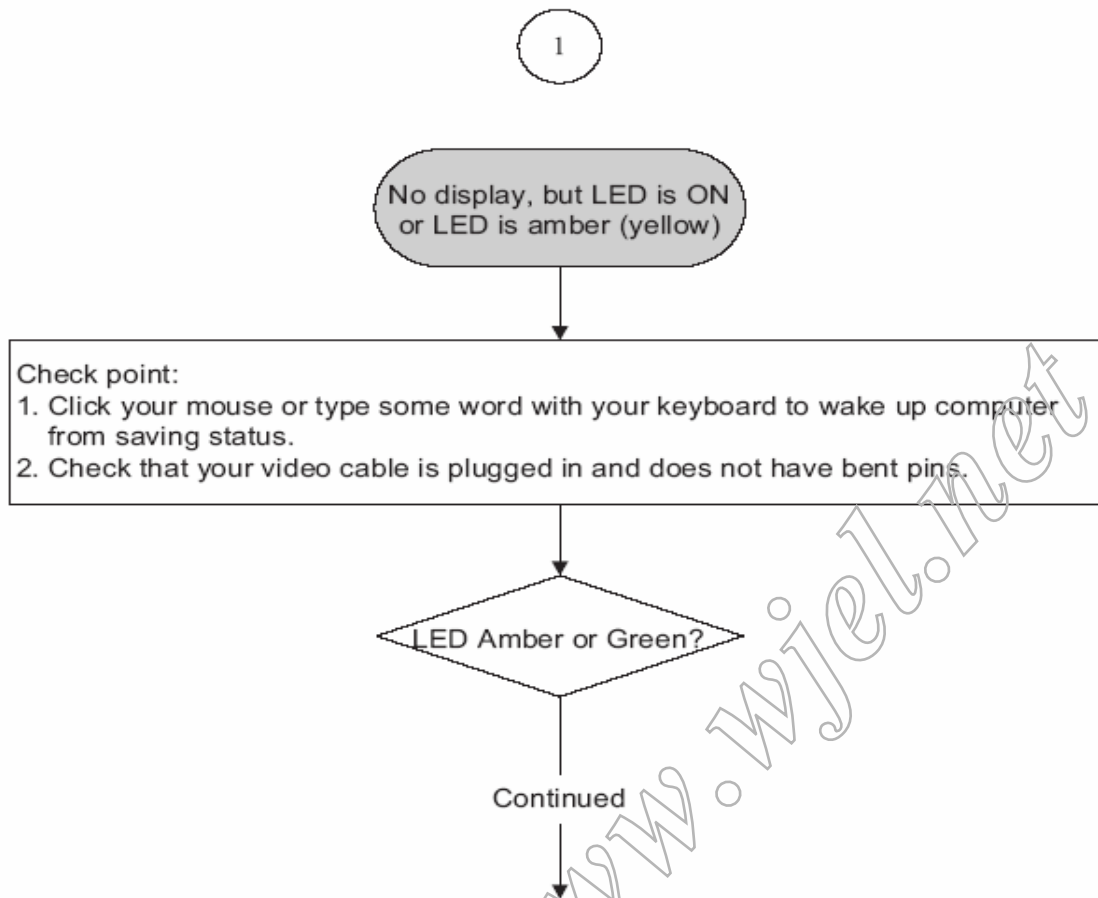

NOTE: Do not set screen saver.
It will cause "no display" problem as above mentioned.
Action: Change timer setting of screen saver or disable screen aver.

General Trouble Shooting Guide

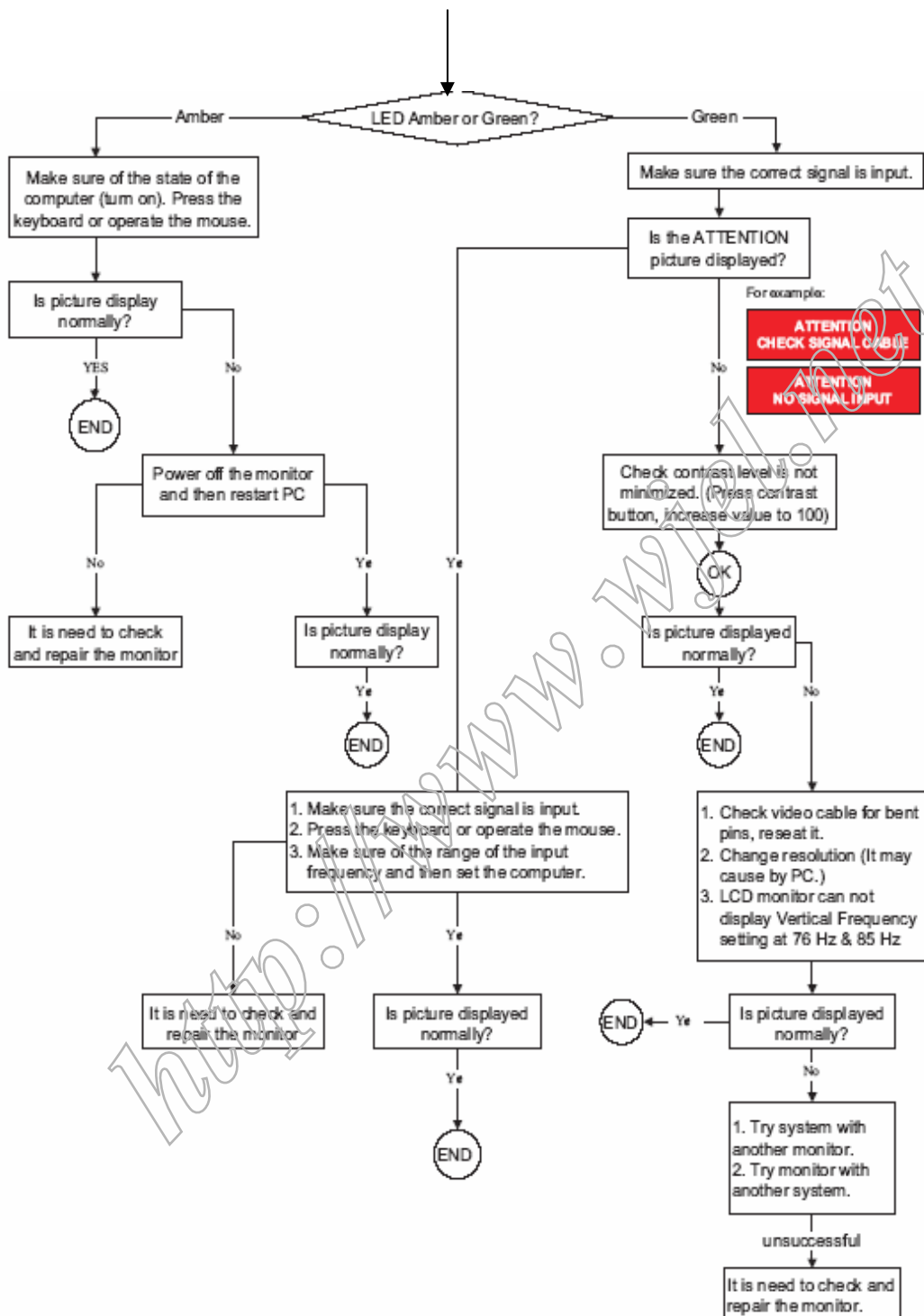

General Trouble Shooting Guide

2

Monitor drivers (inf file)

FOR WINDOWS 95/98/2000/ME OR LATER

Philips's monitors build in VESA DDC2B feature to support Plug & Play requirement for Windows 95/98/2000/Me. You can install the information file(.inf) in order to select your Philips monitor from "Monitor" dialog box in Windows 95/98/2000/Me to activate Plug & Play application. The installation procedure based on Windows 95 OEM Release 2, 98, Me and 2000 is specified as follows, (in case of connecting the monitor to the PC compliant with VESA standard with the designated signal cable, the PC reads display pixels ,frequency and color feature of this monitor to optimize the picture for the monitor automatically.)DDC: Abbreviation for Display Data Channel

For Windows 95
For Windows 95 drivers, your monitor is listed under manufacture name "Philips Business Electronics Co."

For Windows 98
For Windows 98 drivers, our monitors are listed under 2 manufactures name "Philips", and "Philips Consumer Electronics Co." Please select "Philips" when you would like to set up your monitor in Windows setting, if you can not find the right model name just as the label indication on the back of set.
For those set that have been issued since the release of Window 98, drivers can be found in CD-ROM under the directory path of "pcldriver\" or it may be downloaded at <http://www.philips.com>.
Once you have installed the new driver, Windows will add a new manufacture name "Philips Business Electronics" in your system.

For Window Me

For Windows 2000

1. Start Windows 95
2. Click the 'Start' button, point to 'setting', and then click 'control panel'.
3. Double click the 'display' icon.
4. Choose the 'setting' tab then click 'advanced...'
5. Choose 'monitor' button, point to 'change...' then click 'have disk...'
6. Click 'browse...' button then choose the appropriate drive F:(CD-ROM Drive) then click 'ok' button.
7. Click the 'ok' button then choose your monitor mode land click the 'ok'.
8. Click 'close' button.

1. Start Windows 98
2. Click the 'Start' button, point to 'setting', and then click 'control panel'.
3. Double click the 'display' icon.
4. Choose the 'setting' tab then click 'advanced...'
5. Choose 'monitor' button, point to 'change...' then click 'next'.
6. Choose 'display a list of all the drivers in a specify location, so you can select the driver you want', then click 'next' and then click 'have disk...'
7. Click 'browse...' button then choose the appropriate drive F: (RD-ROM Drive) then click 'ok' button.
8. Click the 'ok' button then choose your monitor model and click the 'next' button.
9. Click 'finish' button then click 'close' button.

1. Start Window Me
2. Click the 'start' button, point to 'setting', and then click 'control panel'.
3. Double click the 'display' icon.
4. Choose the 'setting' tab then click 'advanced...'
5. Choose 'monitor' button, then click 'change...' button.
6. Choose 'specify the location of the driver (advanced)' and click the 'next' button.
7. Choose 'display a list of all the drivers in a specific location, so you can select the driver you want', then click 'next' and then click 'have disk...'
8. Click 'browse...' button then choose the appropriate drive F: (CD-ROM Drive) then click 'ok' button.
9. Click the 'ok' button then choose your monitor model and click the 'next' button.
10. Click 'finish' button then click 'close' button.

1. Start Windows 2000
2. Click the 'start' button, point to 'setting', and then click 'control panel'.
3. Double click the 'display' icon.
4. Choose the 'setting' tab then click 'advanced...'
5. Choose 'monitor';
- If the 'properties' button is inactive, it means your monitor is properly configured. Please stop installation.
- If the 'properties' button is active, click 'properties' button.
6. Click 'driver' and then click on 'update driver...' then click on the 'next' button.
7. Choose 'display a list of the known drivers for this device. so that I can choose a specific driver' then click 'next' and then click 'have disk...'
8. Click 'browse...' button then choose the appropriate drive F: (CD-ROM Drive).
9. Click the 'open' button then click the 'ok' button.
10. Choose your monitor model and click the 'next' button.
11. Click 'finish' button and then click the 'close' button. If you can see the 'digital signature not found' window then click the 'yes' button.

General Trouble Shooting Guide

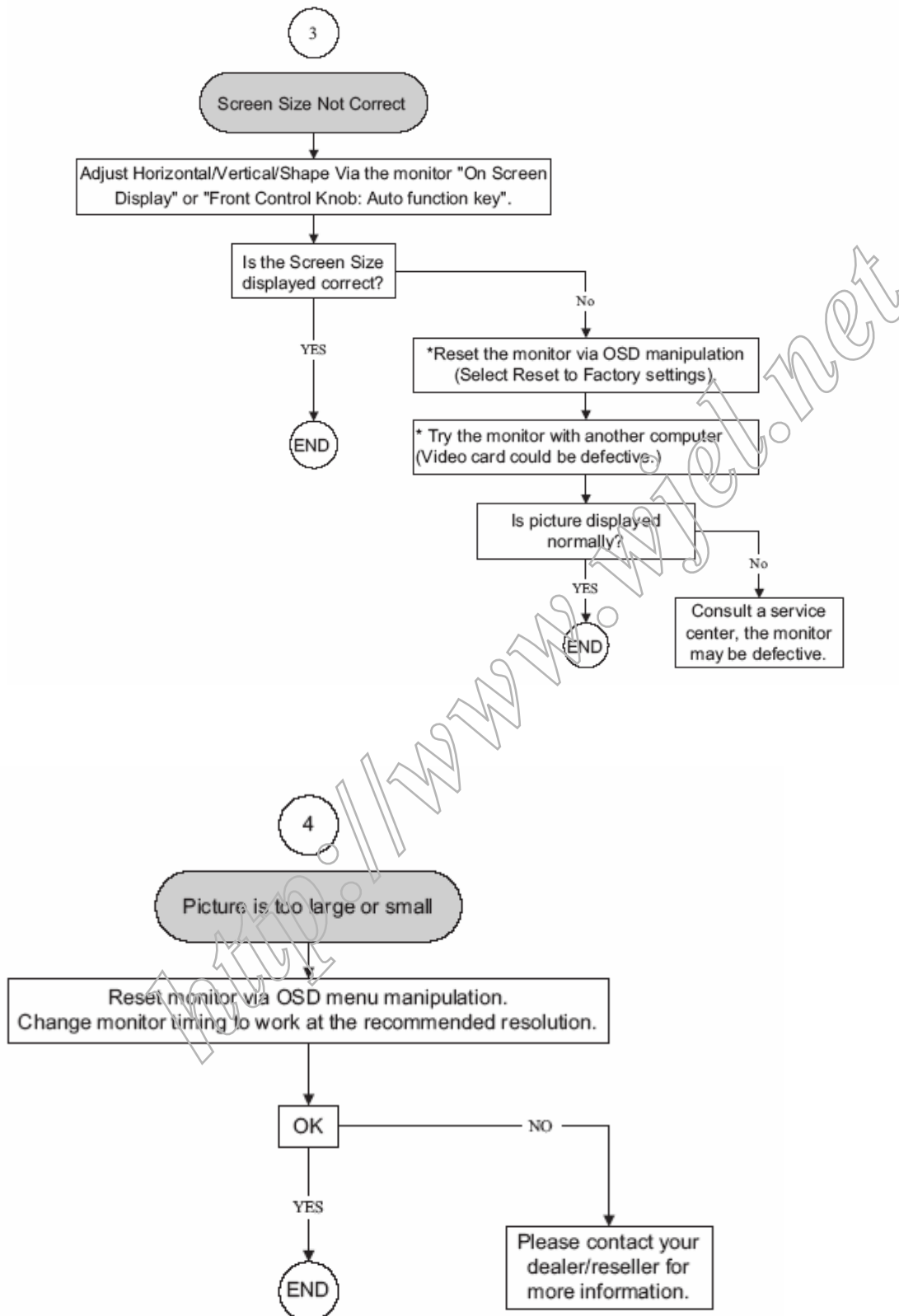

General Trouble Shooting Guide

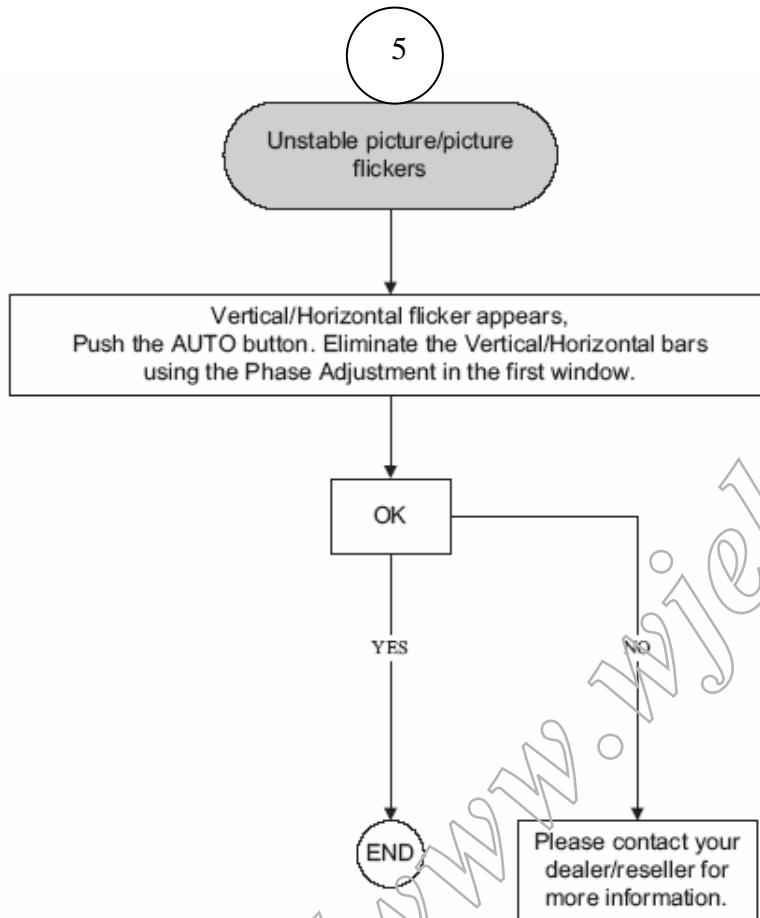

General Trouble Shooting Guide

6

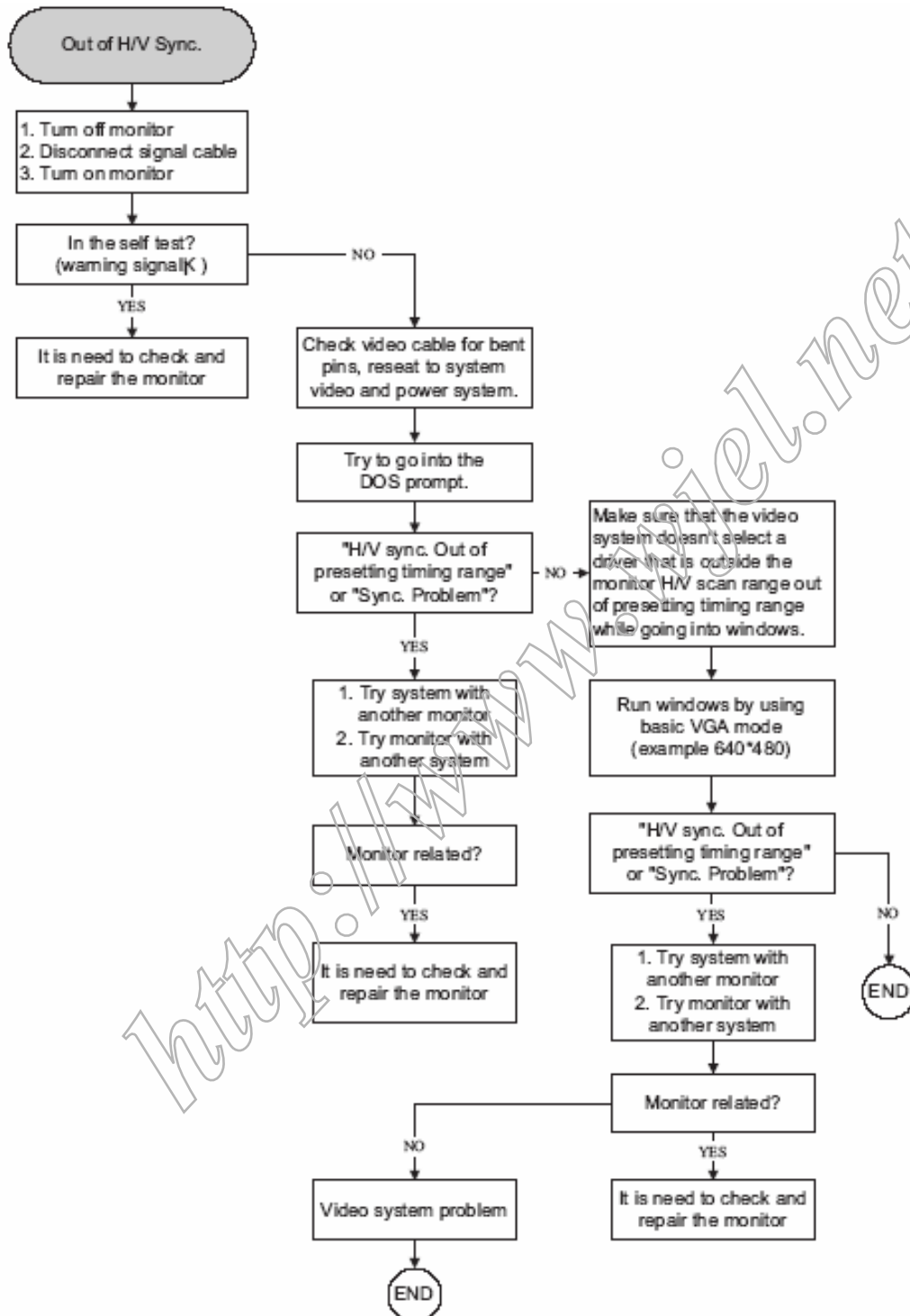

General Trouble Shooting Guide

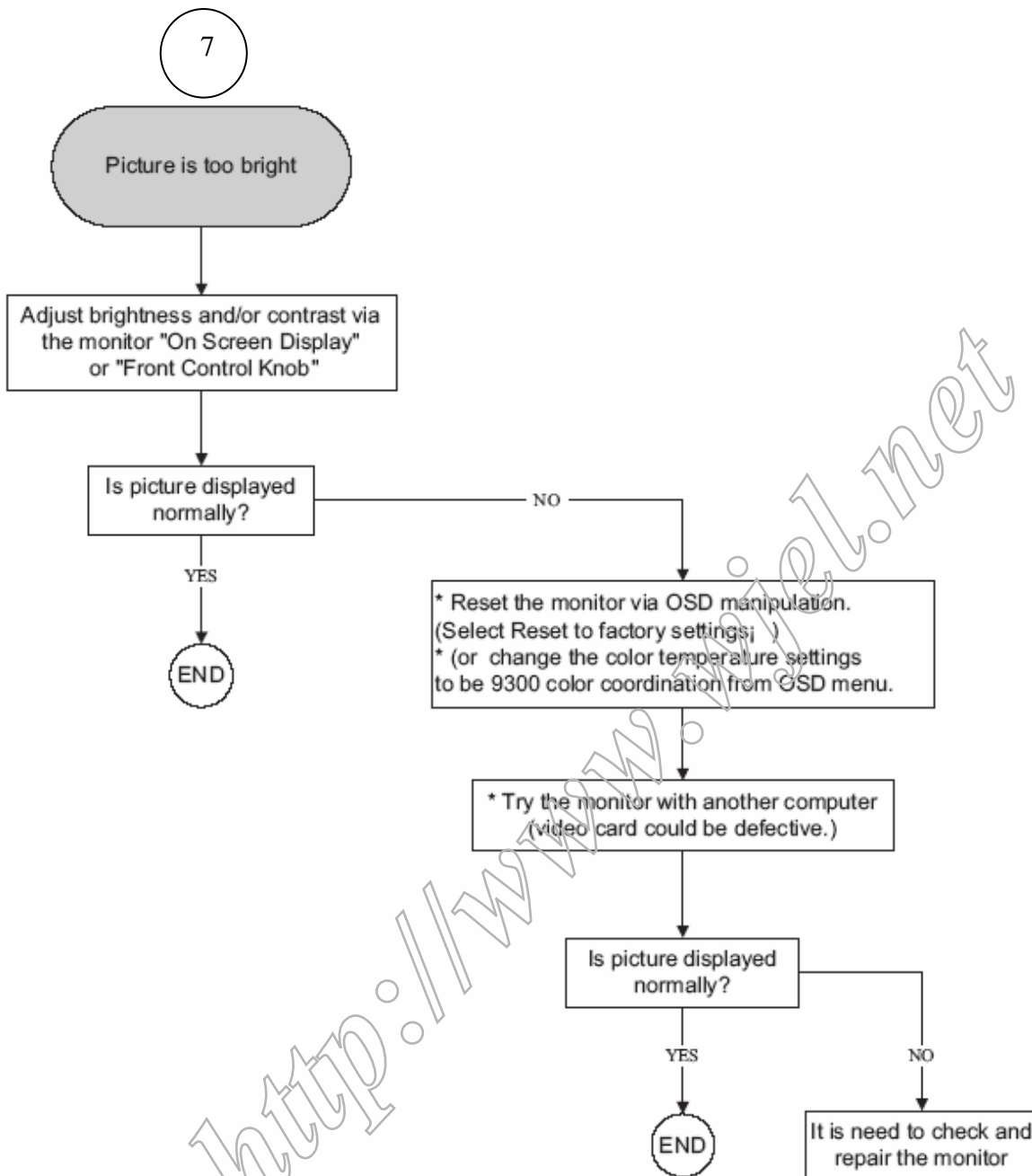

General Trouble Shooting Guide

8

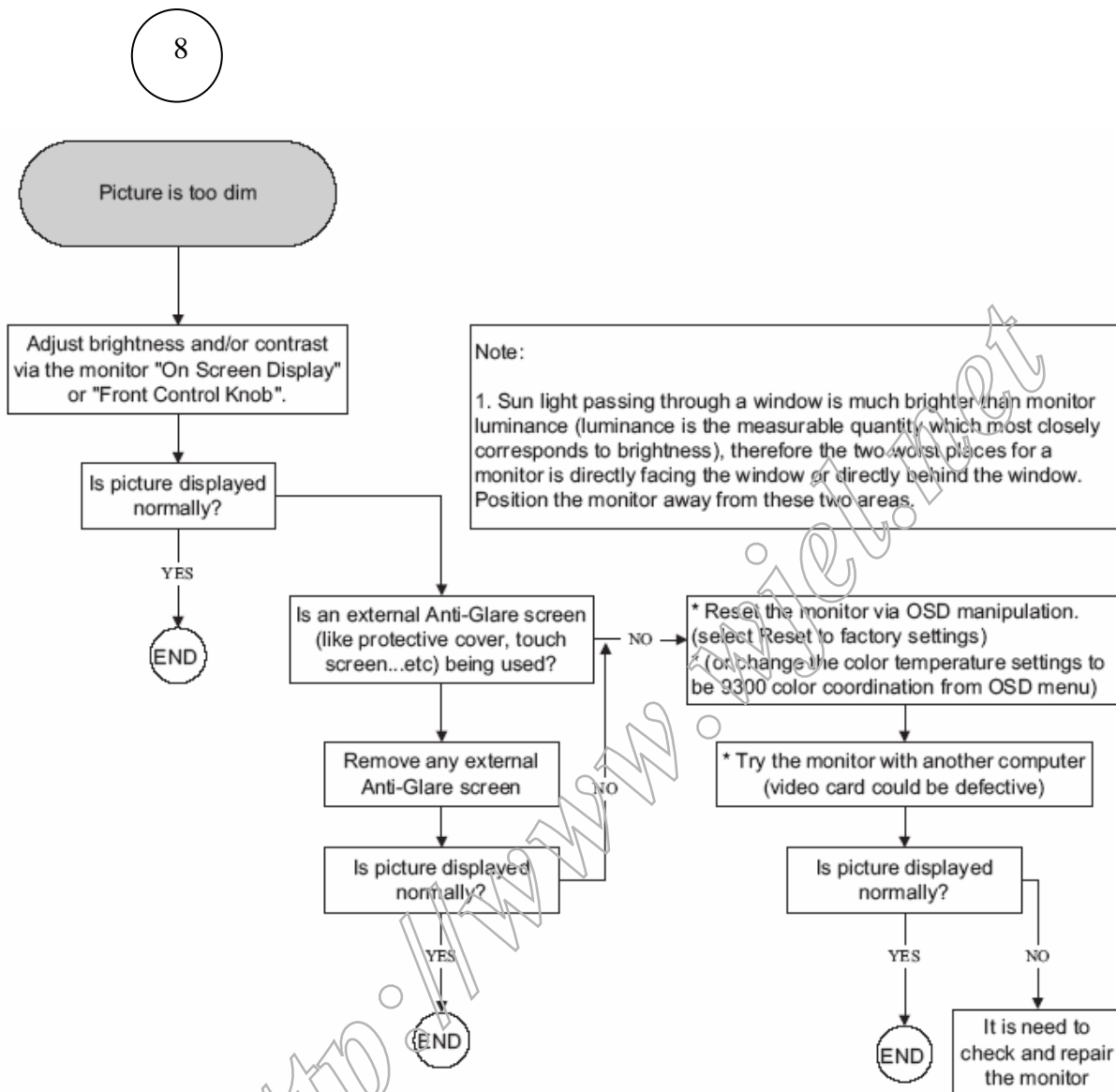

General Trouble Shooting Guide

9

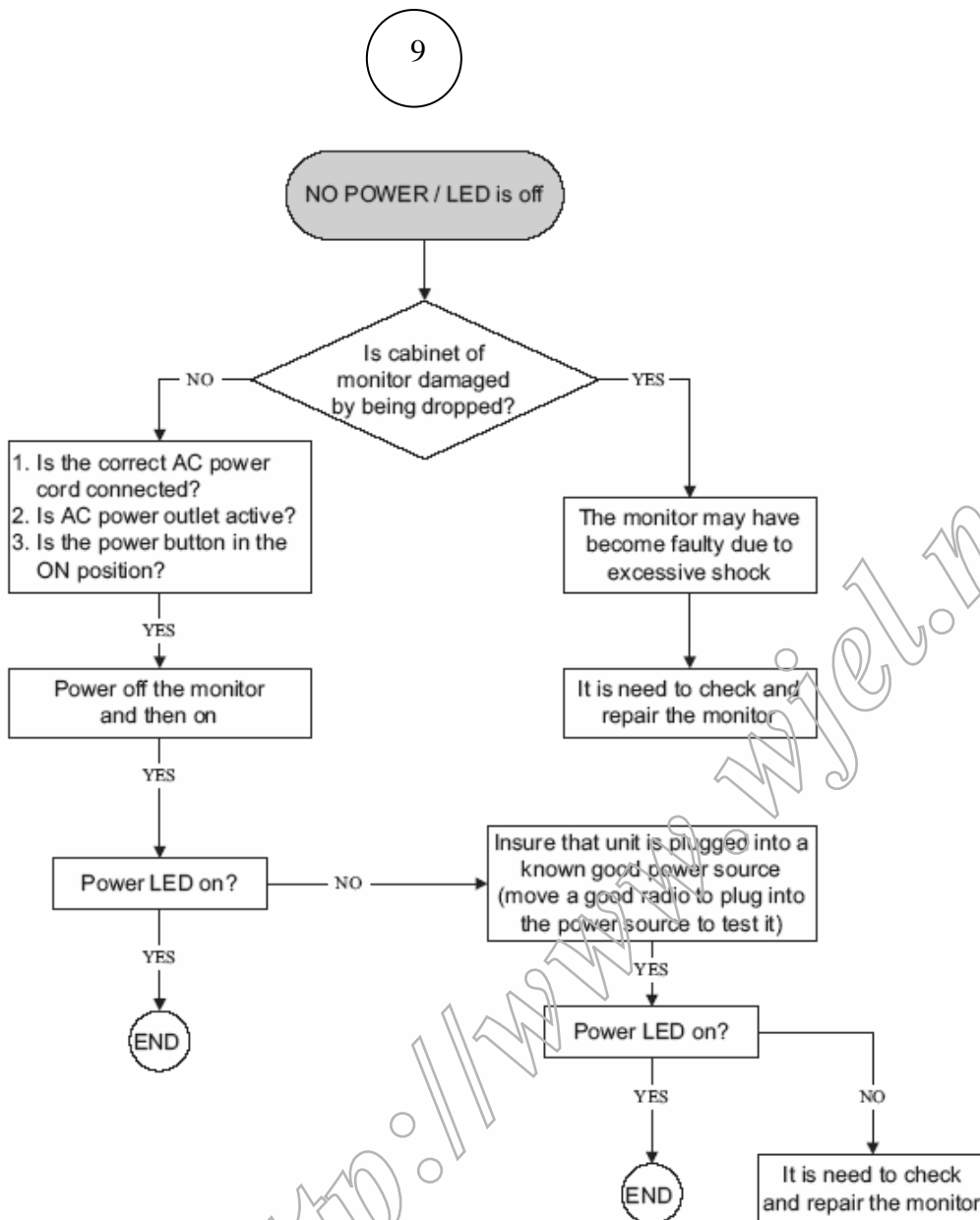

General Trouble Shooting Guide

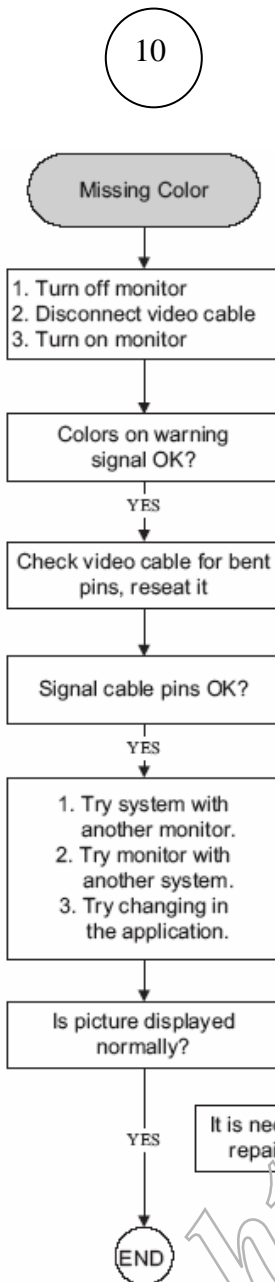

There are 2 easy ways to determine the Missing color problem.

1. View an image that is supposed to be "White".
If one of the colors (RGB) is not functioning, White can not be produced.
2. View an image that supposed to contain Red, Green and Blue.
Color problems will be apparent when one or more of these colors can not be displayed.

Normal White:



Cyan Color means that the red sub pixel is missing.



Magenta or Purple Color means that the green sub pixel is missing.



Yellow Color means that the blue sub pixel is missing.



General Trouble Shooting Guide

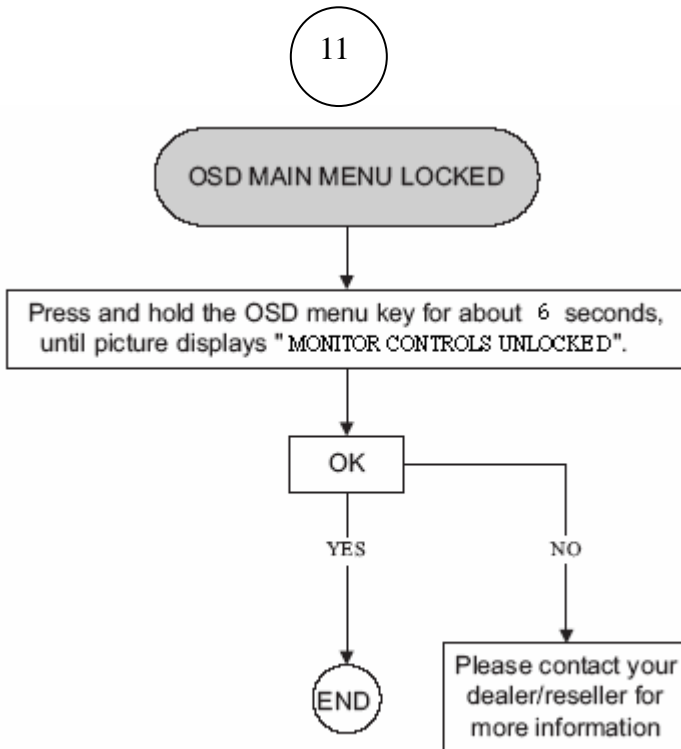

<http://www.wjel.net>

General Trouble Shooting Guide

12

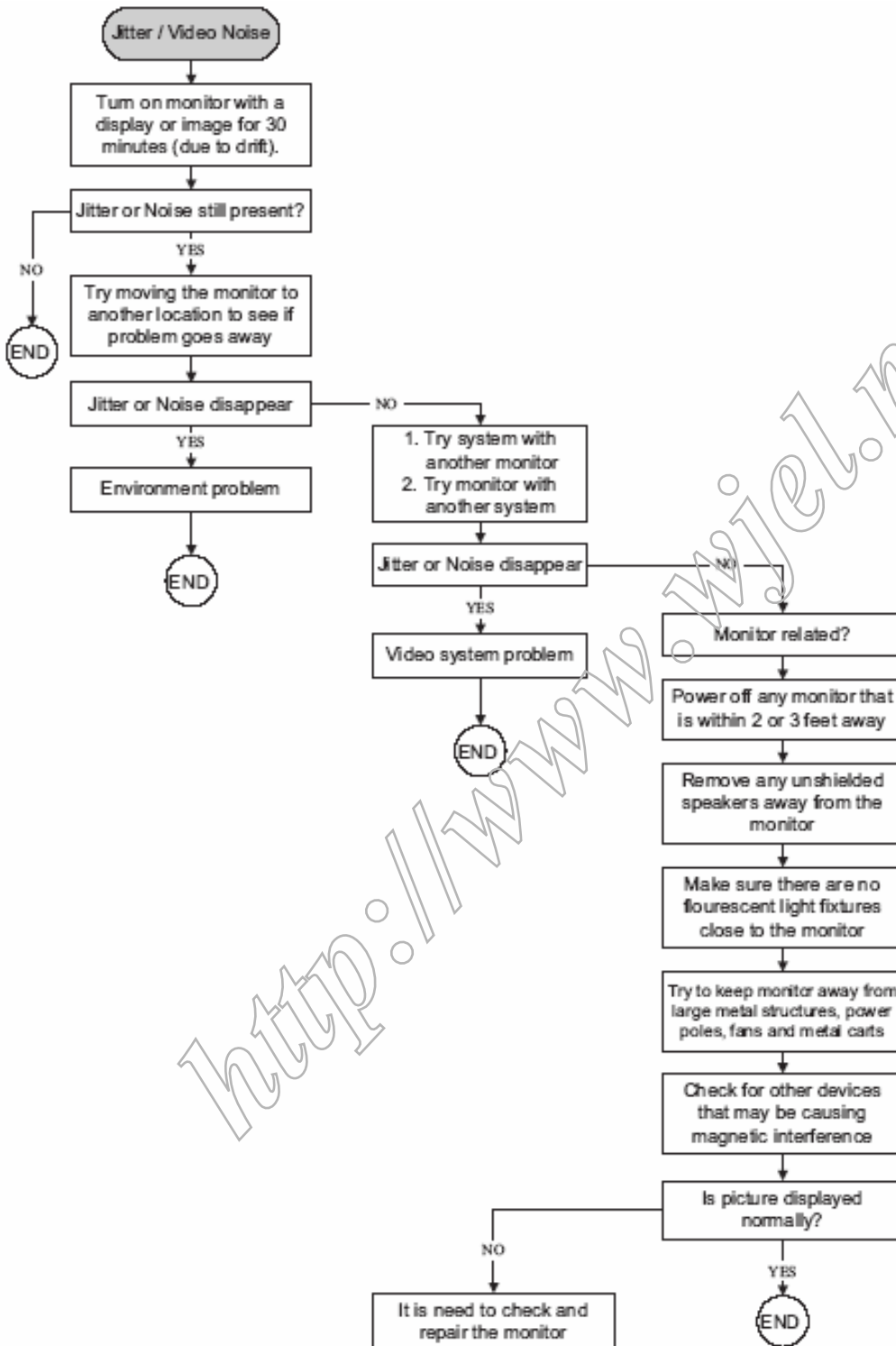

General Trouble Shooting Guide

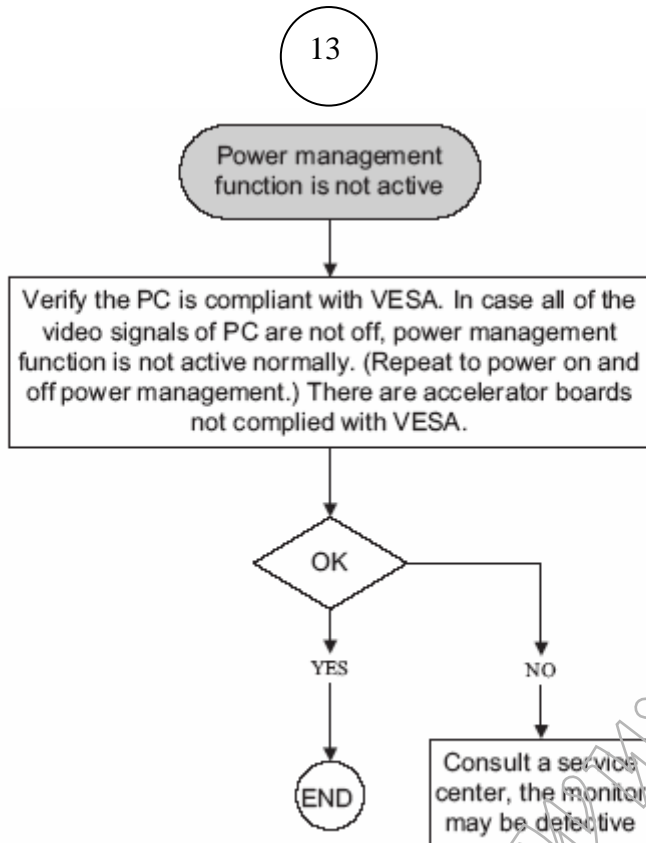

General Product Specification

Specification for LE19E3

Philips Hudson 9 – 190EW9

19"W TFT LCD Monitor,
30 - 83 kHz, 56 - 76 Hz, Analog input

Table of Contents

1.	PRODUCT SPECIFICATION	
	1.1	Relationship
	1.2	Product Data
2.	MECHANICAL SPECIFICATION	
	2.1.1	Monitor Housing
	2.1.2	VESA mounting holes
	2.1.3	Kensington Slot
	2.2	Tilt / Swivel base of the monitor
	2.3	Dimensions of monitor
	2.4	Dimensions of pallet and quantity
3.	LCD SPECIFICATION	
	3.1	LCD specification
4.	COSMETICS APPEARANCE	
	4.1	GAP definition
	4.2	Panel Offset
	4.3	Horizontal tilt
5.	CONNECTORS	
	5.1	Video Connection
	5.2	PIN Assignment
	5.2.1	15 pin mini D-Sub connector
6.	OSD	
	6.1	Control of OSD
	6.2	Adjustment Parameters
7.	ELECTRICAL SPECIFICATION	
	7.1	Power Specification
	7.1.1	AC-DC converter
	7.1.2	Power Management
	7.2	Standard Test conditions
	7.3	Test equipment
	7.4	Video Generator test sequence
	7.5	Analog input
	7.6	Optical response time
	7.7	Protection circuit
	7.8	DDC
	7.8.1	DDC Details
	7.9	Timings
	7.10	Audio Specification

8. DISPLAY PERFORMANCE

- 8.1 Picture performance
- 8.2 Geometric defects
- 8.3 Picture stability during warm up
- 8.4 Scratches
- 8.5 Viewing angle
- 8.6 Jitter
- 8.7 Missing Pixels / missing subpixel
- 8.8 Newton Ring
- 8.9 Luminance Output
 - 8.9.1 Luminance Output
 - 8.9.2 Brightness
 - 8.9.3 Brightness Uniformity
- 8.10 White Uniformity
- 8.11 Contrast ratio
- 8.12 White color adjustment
- 8.13 Distance between TFT LCD monitor and CRT/TFT monitor

9. ENVIRONMENT

- 9.1 Environmental conditions

10. REGULATORY STANDARDS

- 10.1 Safety approvals
- 10.2 Power management
- 10.3 Certificates, Reports for the production start

11. RELIABILITY

- 11.1 Reliability of the monitor

12. CUSTOMIZATION

- 12.1 Identity Customization
- 12.2 EAN /SAP Identification
- 12.3 Plastic
- 12.4 Definition of serial number
- 12.5 Definition of the barcode label
- 12.6 Accessories

13. ECR-HANDLING

<http://www.wjel.net>

1. PRODUCT SPECIFICATION

1.1 Relationship

Customer:	Philips	Model:	LE19E3
* Monitor No:	HWE9 190F	Model:	Hudson 9 -190EW9/190EW
* Monitor ID:			
	190EW9/00		
	190EW9/93		
	190EW9/05		
	190EW9/62		
* EAN No.:			

CTN	UPC/EAN
190EW9/00	8712581428426
190EW9/93	8712581428433
190EW9/05	8712581440459
190EW9/62	8712581453886

1.2 Product Data

19" W TFT LCD monitor

Horizontal frequency	30 - 83	KHz
Vertical frequency	56 - 76	Hz
Screen diagonal	19	Inch
Viewing Angle(CR>10)(H/V)	170°/160 °	
Max. active horizontal picture size	408.24	mm
Max. active vertical picture size	255.15	mm

2. MECHANICAL SPECIFICATION

2.1.1 Monitor Housing

The front bezel and the back cabinet are based on Innolux OEM tooling and Philips design chin.

2.1.2 VESA mounting holes

According to VESA FPMPI standard.

Holes 100 mm x 100 mm (M 4.0, 0.7 pitch threaded) in the rear center for ARM.

2.1.3 Kensington Slot

The monitor is equipped with a 7 mm x 3 mm slot.

2.2 Tilt of the monitor

Forward	-5 q +2/- 2 q
Backward	+14 q+3/- 3 q

2.3 Dimensions of monitor

The monitor has the following dimensions:

Unit dimension	: 437.4mm (W) *374.8mm (H) * 189.1mm (D)
Packed unit dimension	: 490mm (W) *375mm (H) * 138mm (D) for WW
	: 490mm (W) *375mm (H) * 138mm (D) for China
Net weight	: 3.886 Kg (Including I/F cable 240 g)
Gross weight	: 4.989 Kg for WW
	: 4.989 Kg for China

3. LCD SPECIFICATION

3.1 LCD specification

Panel	BOE
	HT190WG1-600
Resolution	1440x900
Active area(HxV)	408.24.x 255.15 mm
Outside dimensions(WxHxD)	428 X 278 X 18.5mm
Pitch(mm)	0.2835(H) x0.2835(V)
Display surface	Non-glare type
Color depth	16.7M colors
Backlight	4CCFL
Viewing angle	170 (H) , 160 (V)
Contrast ratio	1000:1(Typ)
White luminance	300nit(Typ)
Color gamut	72%
Gate IC	TBC
Source IC	TBC
Response time	5ms

4 COSMETICS APPEARANCE

4.1 GAP definition

The gap between LCD and front bezel must be $\leq 1.2\text{mm}$

4.2 Panel Offset

Panel Offset: Panel disposition tolerance inside the front bezel must be $\leq 1.0\text{mm}$

4.2 Horizontal tilt

Horizontal tilt between front bezel & LCD shall be $\leq 3\text{mm}$

5. CONNECTORS

5.1 Video Connection

The monitor is equipped with a 15 pin mini D-SUB connector.

5.2 PIN Assignment

5.2.1 15 pin mini D-Sub connector

The PIN assignment of the 15 pin mini D-SUB connector / cable is as follows:

Pin	Symbol	Pin	Symbol	Pin	Symbol
1	Red	6	Red GND	11	GND
2	Green/SOG	7	Green GND	12	Bi-directional data
3	Blue	8	Blue GND	13	H sync
4	GND	9	+5V	14	V sync
5	CableDetect	10	Open	15	Data clock

6. OSD

6.1 control of OSD

The positions and functions of the buttons are defined as below.

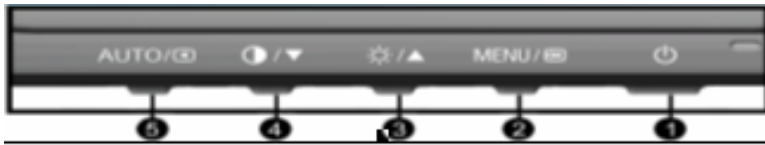

6.2 Adjustment parameters

Hot-key definition

FUNCTION	HOT KEY OPERATION					DESCRIPTION
	AUTO	▼	▲	MENU	POWER	
FACTORY MODE	●			●	ON	Press AUTO + Menu at the same time, and then press [POWER] for DC power on. OSD menu will be shown with "Factory" on the sub -menu of picture. Select "Factory" for entering factory mode.
Brightness			●			To enter Brightness quick access Menu
Contrast		●				To enter Contrast quick access menu
Monitor Controls Lock				●		Lock/Unlock Monitor control when press Menu (6 seconds).
DDC/CI On/OFF For VISTA		●		●		DDC/CI On/OFF when press Menu+▼ (6 seconds).

OSD Tree

Level 1	Level 2	Level 3	Default
Picture	Picture Format	4:3	
		Wide screen	
	Brightness	(0~100)	100
	Contrast	(0~100)	50
Color	Color Temperature	(6500k,9300k)	6500k
	sRGB		
	User Define	(Red:0~100)	100
		(Green:0~100)	100
(Blue:0~100)		100	
Language	English		(English)
	Español		
	Français		
	Deutsch		
	Italiano		
	Português		
	Русский		
	Türkçe		
	简体中文		

OSD settings	Horizontal	(0~100)	50
	Vertical	(0~100)	50
	Transparency	(Off, 1,2,3,4)	Off
	OSD Time out	(5s,10s,20s,30s,60s)	20s
Setup	Phase	(0~100)	
	Clock	(0~100)	
	H.Position	(0~100)	
	V.Position	(0~100)	
	Reset	(Yes,No)	No
	Resolution Notification	(On,Off)	Off
	Information		

7. ELECTRICAL SPECIFICATION

7.1 Power Specification

7.1.1 AC-DC converter

Input voltage	90- 264V
Frequency range	50~ 60 Hz
Inrush current	Shall be less than the ratings of critical components (including fuse, rectifiers and surge limiting device) for all conditions of line in voltage.
consumption:	≤42W (Max)

7.1.2 Power Management

Mode	HSYNC	VSYNC	Video	Pwr-cons.	Indication	Rec. time
Power-On	On	On	active	≤ 42 W	Green LED	--
Off(sleep mode)	Off	Off	blanked	≤ 2 W	Amber LED	< 3 s
DC Power Off			N/A	≤ 1 W	LED Off	

7.2 Standard Test conditions

Unless otherwise specified, this specification is defined under the following conditions.

- (1) Input signal: As defined in Timing table, 1440 x 900 non-interlaced mode (1440X900@60Hz 136.75MHz), signal sources must have 75 ohm output impedance.
- (2) Luminance setting: controls to be set to 300 nits with full screen 100 % duty cycle white signal
- (3) Warm up: more than 30 minutes after power on with signal supplied.
- (4) Ambient light: 400 – 600 lux.
- (5) Ambient temperature: 20 ± 5 °C

7.3 Test equipment

Personal computer with Windows 98/2000/XP
 Luminance meter Minolta CA210
 Videogenerator: Chroma 2227, 2230 or equivalent
 Colour analyzer: Minolta or Chroma
 10 times magnifier
 Ruler / Template
 Thickness gauge
 Watt / Power Meter

7.4 Video Generator test sequence

Will be defined by Innolux or its subcontracted quality providers.

7.5 Analog input

Analog input R,G,B level: 0 - 700 mV max.
 Polarity: positive, negative
 Impedance: 75 ohm
 Sync: HV separate sync, composite sync,

7.6 Optical response time

Video Bandwidth: 136 MHz (dot rate)
 Typical response time(BOE) 5ms

7.7 Protection circuit

The monitor will not be damaged by:
 improper vertical or horizontal sync pulse (picture must be black at improper signals, unsynchronized pictures are not allowed)

7.8 DDC

The monitor can support DDC 2 B and DDC-CI according to the latest VESA standard.

7.8.1 DDC Details

1	User visible strings on .inf file	Philips 190EW (19inch WIDE LCD MONITOR 190EW9)
2	Manufacturer ID (EDID data)	PHL
3	Product ID, "xxxx" 4 codes	MSB(byte 12): C0 LSB (byte 11): 1E
4	maximum resolution	1440x900
5	Horizontal Frequency Range	30~83 KHz
6	Vertical Frequency Range	56~76Hz
7	Monitor Name (13 characteres max.)	Philips 190EW

7.9 Timings

Factory preset modes : 13
Preset modes : 47
User modes : 10

Note: 1.screen displays perfect picture at 13 factory-preset modes.
2.screen displays visible picture with OSD warning when input modes are the 48 preset modes.

Factory preset mode(13 modes)

Item	H.Freq. (KHz)	Mode	Resolution	V.Freq. (Hz)	BW(MHz)
1	31.469	IBM VGA 10H	640x350	70.086	25.18
2	31.469	IBM VGA 3H	720x400	70.087	28.3
3	31.469	IBM VGA 12H	640x480	59.94	25.175
4	35	MACINTOSH	640x480	67	30.24
5	37.861	VESA	640x480	72.809	31.5
6	37.5	VESA	640x480	75	31.5
7	43.269	VESA	640x480	85.008	36
8	35.156	VESA	800x600	56.25	36
9	37.879	VESA	800x600	60.317	40
10	48.077	VESA	800x600	72.188	50
11	46.875	VESA	800x600	75	49.5
12	53.674	VESA	800x600	85.061	56.25
13	49.7	MACINTOSH	832x624	75	57.3
14	56.4	-	960x720	75	72.192
15	44.75	-	960x720	60	55.86
16	48.363	VESA	1024x768	60.004	65
17	56.476	VESA	1024x768	70.069	75
18	60.023	VESA	1024x768	75.029	78.75
19	61.08	IBM XGA-2	1024x768	75.781	80
20	68.677	VESA	1024x768	84.997	94.5
21	47.78	CVT 2.3MA	1280 x768	60	79.5
22	60.289	CVT 2.3MA	1280 x768	75	102.25
23	54.1		1152x864	60	81.6
24	63.851	VESA	1152x864	70.012	94.5
25	67.5	VESA	1152x864	75	108

26	68.7	MACINTOSH	1152x870	75	100
27	61.845	SUN WS	1152x900	66.004	94.88
28	71.81	SUN WS	1152x900	76.15	108.23
29	60	VESA	1280x960	60	108
30	75	VESA	1280x960	75	130
31	63.981	VESA	1280x1024	60.02	108
32	71.691	SUN WS	1280x1024	67.189	117.01
33	76	DOS/V	1280x1024	72	132.752
34	79.976	VESA	1280x1024	75.025	135
35	81.13	SUN WS	1280x1024	76.11	134.99
36	91.1	VESA	1280x1024	85	157.5
37	44.772	-	1280x720	60	74.5
38	52.5	-	1280x720	70	89.04
39	64	CVT-reduced blanking	1400x1050	60	121.75
40	80	CVT	1400x1050	75	156.001
41	91.1	CVT	1400x1050	85	
42	55.469	VESA-reduced blanking mode	1440x900	59.901	88.75
43	55.935	VESA	1440x900	59.887	106.5
44	70.635	VESA	1440x900	74.284	136.75
45	75	VESA	1600x1200	60	161
46	65.29	CVT1.76MW	1680x1050	60	146
47	64.7	CVT1.76MW-R	1680x1050	60	119

Remark, Timing with light blue are factory mode.

7.10 Audio Specification

N/A

8. DISPLAY PERFORMANCE

8.1 Picture performance

Optical performance test must be done in a dark room.

Note: Test under standard test conditions unless otherwise specified

Active Image Size (all modes)

8.2 Geometric defects

No vertical or/and horizontal line defect.

No cross line defect.

8.3 Picture stability during warm up

During 10 - 30 minutes warm up time from cold condition of the monitor

at ambient temperature (25°C ± 5°C) the decrease of brightness must be less than 6 FI.

8.4 Scratches

No scratches and foreign particles visible.

8.5 Viewing angle

	Typical(10:1)
Horizontal (Right + Left)	170°
Vertical (Up + Down)	160°

8.6 Jitter

No jitter visible in each condition. In case of problem a limit sample has to be defined.

8.7 Missing Pixels / missing subpixel

MODEL	190EW9
1 lit subpixel	3
2 adjacent lit subpixels	1
3 adjacent lit subpixels (one white pixel)	0
Distance between two bright dot defects*	15mm
Bright dot defects within 20 mm circle	0
Total bright dot defects of all types	3

MODEL	190EW9
1 dark subpixel	5
2 adjacent dark subpixels	2
3 adjacent dark subpixels (one white pixel)	1
Distance between two dark dot defects*	15mm
Black dot defects within 20 mm circle	1
Total black dot defects of all types	5

MODEL	190EW9
Total bright or black dot defects of all types	5

8.8 Newton Ring

No Newton Rings visible.

8.9 Luminance Output

8.9.1 Luminance Output

Test resolution: 1440 x 900 at 60 Hz
 Test condition: video input (RGB) = maximum white

8.9.2 Brightness

To follow Panel specification. sRGB = 80 ± 10 nits.

8.9.3 Brightness uniformity

Set contrast at 100% and turn the brightness to get average above 300 nits at centre of the screen. Apply the Fig 1, it should comply with the following formula:

$$\frac{B_{\min}}{B_{\max}} \times 100\% > 75\%$$

Where B_max = Maximum brightness
B_min = Minimum brightness

8.10 White Uniformity

Definition of White Variation (W):

Measure the luminance of gray level 255 at 9 points

$W = \text{Maximum [L(1), L(2) \dots L(9)]} / \text{Minimum [L(1), L(2) \dots L(9)]}$

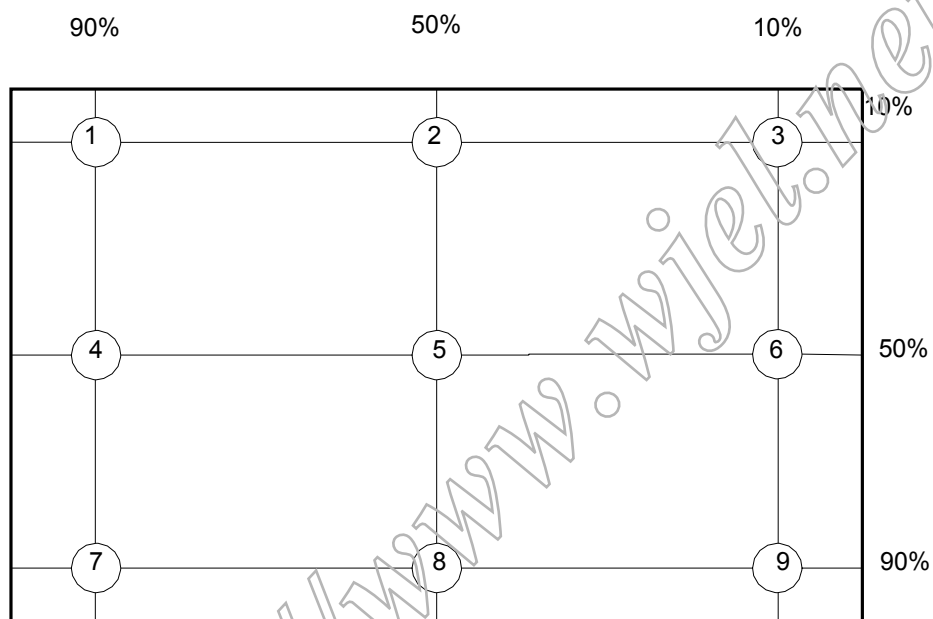

Spec : ≤ 1.33 (In all ranges)

8.11 Contrast ratio

The contrast ratio can be calculated by following expression.

Contrast Ratio (CR) = L_{255} / L_0

L255 : Luminance of gray level 255

L0 : Luminance of gray level 0

Typical value: 1000:1

8.12 White color adjustment

Apply full gray 64 pattern, with brightness in 100 % position and the contrast control at 50 % position. The 1931 CIE Chromaticity (color triangle) diagram (x,y) coordinate for the screen center should be:

Mode		Chromaticity Coordinate		Remark
OSD setting	Temp.	x	y	
Warm	6500K	0.313 ± 0.020	0.329 ± 0.020	For product Spec(DQA test)
		0.313 ± 0.015	0.329 ± 0.015	For OQC Test:
		0.313 ± 0.005	0.329 ± 0.005	For production alignment test
Cool	9300K	0.283 ± 0.020	0.298 ± 0.020	For product Spec(DQA test)

		0.283 ±0.015	0.298±0.015	For OQC Test:
		0.283 ±0.005	0.298±0.005	For production alignment test
User		Panel White x	Panel White y	

The test standard condition :Brightness control is at 100 contrast control is at 50

8.13 Distance between TFT LCD monitor and CRT/TFT monitor

Conducted with different modes or frequencies. No interference in a distance down to 25 cm.

9. ENVIRONMENT

9.1 Environmental characteristics

The following sections define the interference and susceptibility condition limits that might occur between external environment and the display device.

Operating:

- Temperature : 0 to 40 degree C
- Humidity : 20% to 90% (non-condensed)
- Altitude : 0~ 3048 M (10000 ft)

Storage:

- Temperature : -20 to 60 degree C
- Humidity : 10% to 90%(non-condensed)
- Altitude : 0 to 9144M (30000 ft)

Note: recommend at 5 to 35qC, Humidity less than 60 %

10. REGULATORY STANDARDS

Note: All certificates must be raised under the name of Philips

10.1 Safety approvals

- ; CB report
- ; CE

10.2 Power management

- ; Energy Star

10.3 Certificates, Reports for the production start

When the first production of the monitor starts the following documents must be sent to Philips by mail. All reports must be raised under "Philips" and have to show W0ZR model name .

- ; CB report
- ; CE
- ; FCC
- ; Service manual

11 RELIABILITY

11.1 Reliability of the monitor

The MTBF of the monitor has to be greater than 50.000 hours.

12. CUSTOMIZATION

12.1 Identity Customization

Refer to SKU

12.2 EAN /SAP Identification

Refer to SKU

12.3 Plastic

The plastic material of the monitor must be ABS-HB (base/Front/ back). Plastic type and color is released as follows:

Refer to MakeUp sheet/ Graphic sheet

12.4 Definition of serial number

Refer to Philips' definition

12.5 Definition of the barcode label

Refer to Philips' definition

12.6 Accessories

Refer to SKU

13. ECR-HANDLING

Not any change without approved ECR.

Every ECR to the golden " samples" must be approved by PHILIPS, Even ECR for minor changes must be released by PHILIPS.

For the ECR procedure the vendor has to send an ECR formular, necessary spec updates, datasheets and a photo documentation. On based on documents, PHILIPS has to decide if samples are necessary till release to changes. The vendor also has to proof be certificates and test reports, that the change has no effect on safety, EMI and TCO03.

After testing, PHILIPS has to release or reject the change request

Safety Check Process

Safety Checks

After the original service problem has been corrected, a complete safety check should be made. Be sure to check over the entire set, not just the areas where you have worked. Some previous service may have left an unsafe condition, which could be unknowingly passed on to your customer. Be sure to check all of the following:

Fire and Shock Hazard

1. Be sure all components are positioned in such a way as to avoid the possibility of adjacent component shorts. This is especially important on those chassis which are transported to and from the service shop.
2. Never release a repaired unit unless all protective devices such as insulators, barriers, covers, strain reliefs, and other hardware have been installed in accordance with the original design.
3. Soldering and wiring must be inspected to locate possible cold solder joints, solder splashes, sharp solder points, frayed leads, pinched leads, or damaged insulation (including the cord). Be certain to remove loose solder balls and all other loose foreign particles.
4. Check across-the-line components and other components for physical evidence of damage or deterioration and replace if necessary. Follow original layout, lead length and dress.
5. No lead or component should touch a receiving tube or a resistor rated at 1 watt or more. Lead tension around protruding metal surfaces or edges must be avoided.
6. Critical components having special safety characteristics are identified with an asterisk in the parts list and enclosed within a broken line *(Where several critical components are grouped in one area) along with the safety symbols on the schematic diagrams and/or exploded views.
7. When servicing any unit, always use a separate isolation transformer for the chassis failure to use a separate isolation transformer may expose you to possible shock hazard, and may cause damage to servicing instruments.
8. Many electronic products use a polarized ac line cord (one wide pin on the plug). Defeating this safety feature may create a potential hazard to the service and the user. Extension cords which do not incorporate the polarizing feature should never be used.
9. After reassembly of the unit, always perform a leakage test or resistance test from the line cord to all exposed metal parts of the cabinets. Also check all metal control shafts (with knobs removed), antenna terminals, handles, screws, etc. To be sure the unit may be safely operated without danger of electrical shock.

- Broken line

Implosion

1. All picture tubes used in current model receivers are equipped with an integral implosion system care should always be used, and safety glasses worn, whenever handling any picture tube. Avoid scratching or otherwise damaging the picture tube during installation.
2. Use only replacement tubes specified by the manufacturer.

X-radiation

1. Be sure procedures and instructions to all your service personnel cover the subject of X-radiation. Potential sources of X-rays in TV receivers are the picture tube and the high voltage circuits. The basic precaution which must be exercised is to keep the high voltage at the factory recommended level.
2. To avoid possible exposure to X-radiation and electrical shock, only the manufacturer's specified anode connectors must be used.
3. It is essential that the service technician has an accurate HV meter available at all times. The calibration of this meter should be checked periodically against a reference standard.
4. When the HV circuitry is operating properly there is no possibility of an X-radiation problem. High voltage should always be kept at the manufacturer's rated value—no higher—for optimum performance. Every time a color set is serviced, the brightness should be run up and while monitoring the HV with a meter to be certain that the HV is regulated correctly and does not exceed the specified value. We suggest that you and your technicians review test procedures so that HV regulation are always checked as a standard servicing procedure, and the reason for this prudent routine is clearly understood by everyone. It is important to use an accurate and reliable HV meter. It is recommended that the HV recorded on each customer's invoice, which will demonstrate a proper concern for the customer's safety.
5. When troubleshooting and making test measurements in a receiver with a problem of excessive high voltage, reduce the line voltage by means of a variac to bring the HV into acceptable limits while troubleshooting. Do not operate the chassis longer than necessary to locate the cause of the excessive HV.

6. New picture tubes are specifically designed to withstand higher operating voltages without creating undesirable X-radiation. It is strongly recommended that any shop test fixture which is to be used with the new higher voltage chassis be equipped with one of the new type tubes designed for this service. Addition of a permanently connected HV meter to the shop test fixture is advisable. The CRT types used in these new sets should never be replaced with any other types, as this may result in excessive X-radiation.

7. It is essential to use the specified picture tube to avoid a possible X-radiation problem.

8. Most TV receivers contain some type of emergency "Hold Down" circuit to prevent HV from rising to excessive levels in the presence of a failure mode.

These various circuits should be understood by all technicians servicing them, especially since many hold down circuits are inoperative as long as the receiver performs normally.

Leakage Current Cold Check

1. Unplug the ac line cord and connect a jumper between the two prongs of the plug.
2. Turn on the power switch.
3. Measure the resistance value between the jumpered ac plug and all exposed cabinet parts of the receiver, such as screw heads, antennas, and control shafts. When the exposed metallic part has a return path to the chassis, the reading should be between 1 megohm and 5.2 megohms. When the exposed metal does not have a return path to the chassis, the reading must be infinity. Remove the jumper from the ac line cord.

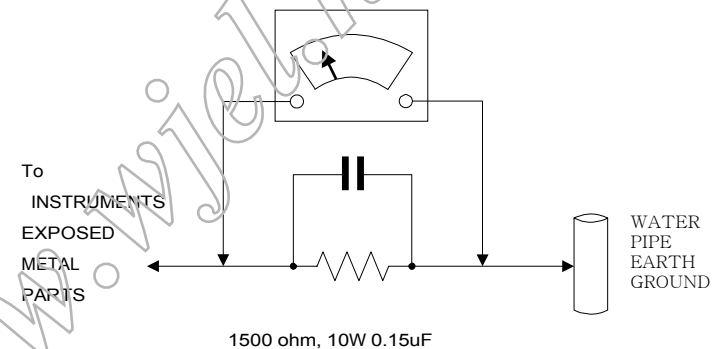

Leakage Current Hot Check

1. Do not use an isolation transformer for this test. Plug the completely reassembled receiver directly into the ac outlet.
2. Connect a 1.5k, 10w resistor paralleled by a 0.15uF capacitor between each exposed metallic cabinet part and a good earth ground such as a water pipe, as shown above.
3. Use an ac voltmeter with at least 5000 ohms volt sensitivity to measure the potential across the resistor.
4. The potential at any point should not exceed 0.75 volts. A leakage current tester may be used to make this test; leakage current must not exceed a possibility of shock hazard. The receiver should be repaired and rechecked before returning it to the customer.
5. Repeat the above procedure with the ac plug reversed. (note: an ac adapter is necessary when a polarized plug is used. Do not defeat the polarizing feature of the plug.)

Picture Tube Replacement

The primary source of X-radiation in this television receiver is the picture tube. The picture tube utilized in this chassis is specially constructed to limit X-radiation emissions. For continued X-radiation protection, the replacement tube must be the same types as the original, including suffix letter, or a Philips approved tube.

Parts Replacement

Many electrical and mechanical parts in Philips television sets have special safety related characteristics. These characteristics are often not evident from visual inspection nor can the protection afforded by them necessarily be obtained by using replacement components rated for higher voltage, wattage, etc. The use of a substitute part which does not have the same safety characteristics as the Philips recommended replacement part should in this service manual may create shock, fire, or other hazards.

WARNING: Before removing the back cover, turn the unit OFF and short the HIGH VOLTAGE to the ground.

~ END ~

<http://www.wjel.net>