

* Differences according to regions.
Display design and accessories may differ from those illustrated above.

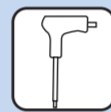

Not included:

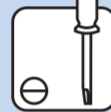

1

Unpacking



Notes:

1. After unpacking, ensure that the modules are in good condition. If anything is damaged or broken, please contact your local service center immediately.
2. Use a pair of scissors to cut vacuum packaging, then take the modules out of the package. Be extremely careful not to damage the module when using the scissors.
3. It is required to wear anti-static gloves before handling the cabinet.
4. Do not place the display vertically on the floor, as it may fall down and get damaged. (The damage will not be covered by warranty)

Rear/top/side/bottom views

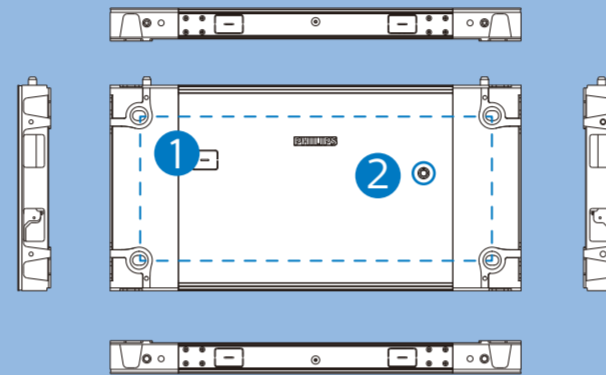

- 1 Mounting holes for screw bolt
- 2 CHECK button

2

Removing the opening

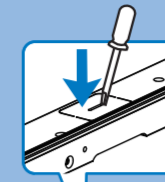

⚠ Before breaking the opening, determine the number of displays to install and the installation layout to form a large video wall array.

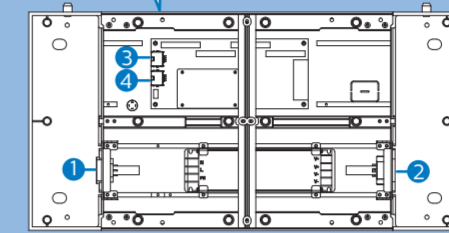

- 1 POWER IN connector
- 2 POWER OUT connector
- 3 DATA connector
- 4 DATA connector

3

Connecting the cabinets



a

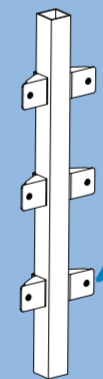
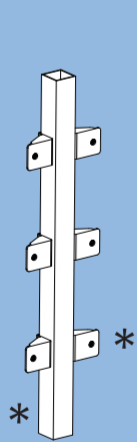

Optional accessory
CTN: BM907006

b

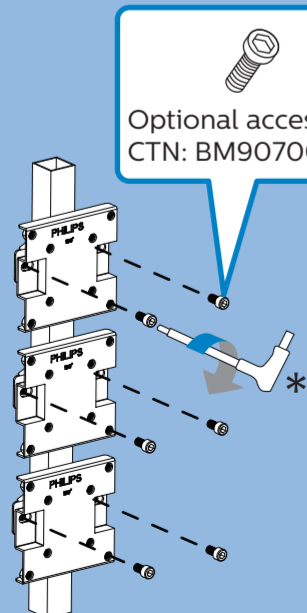

Optional accessory
CTN: BM907005

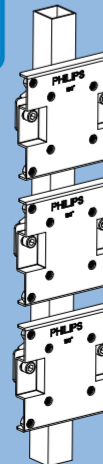

Optional accessory
CTN: BM907000

* Not included

c

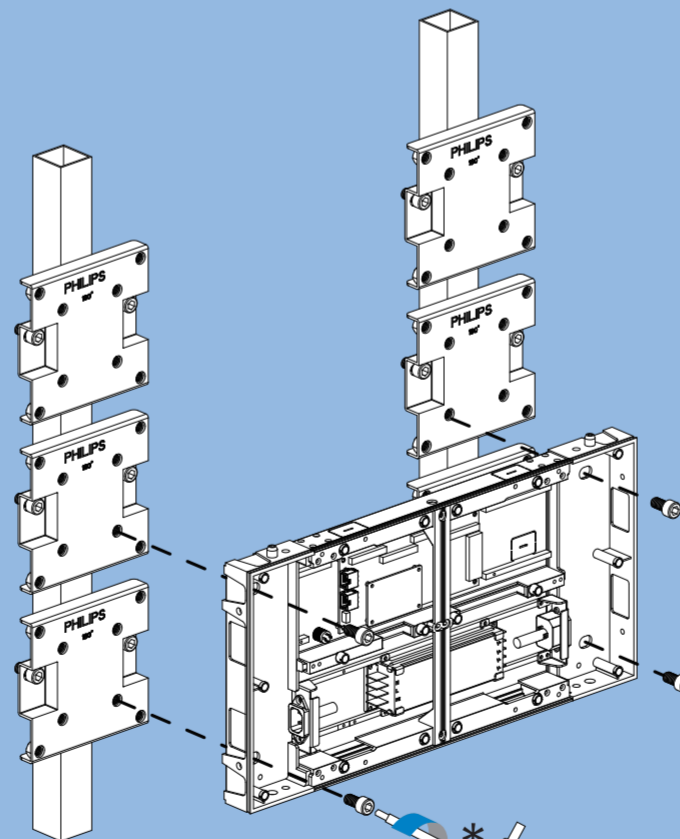

T style inner hexagon
wrench, size 7

d

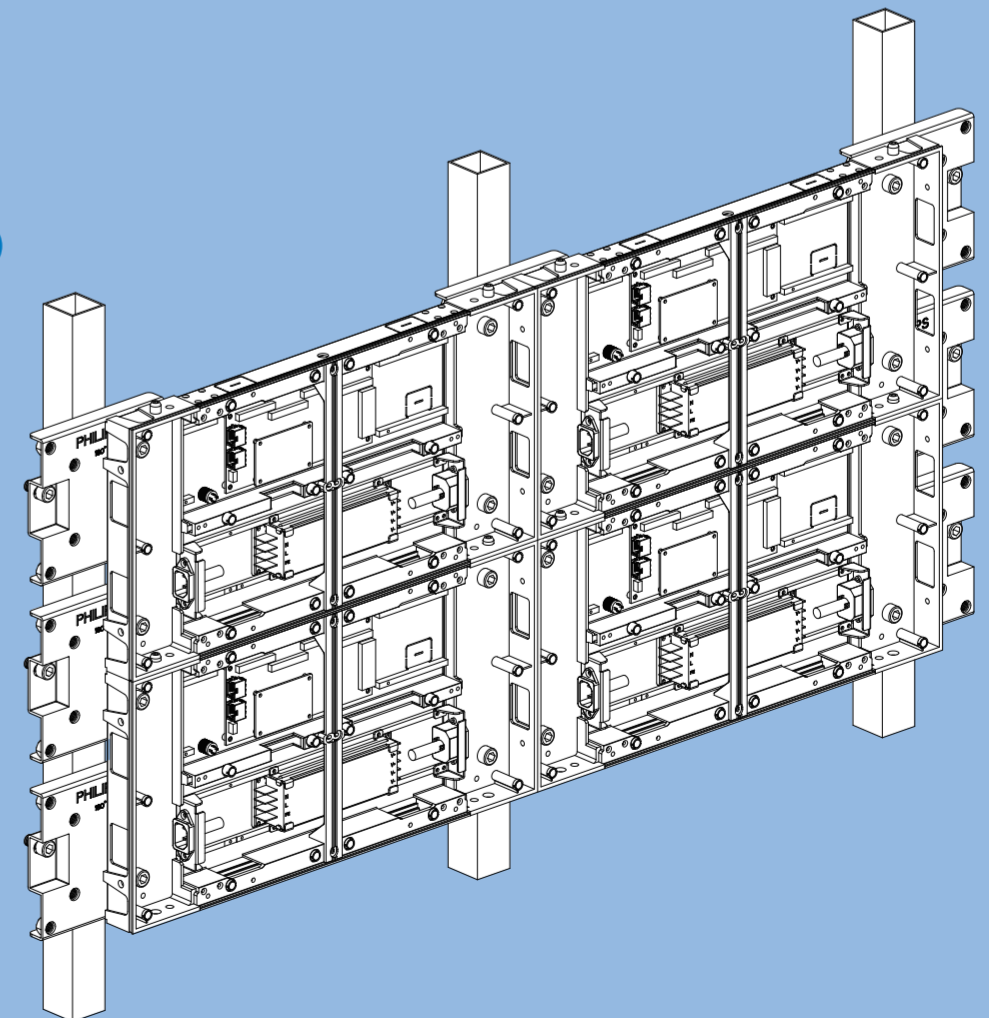

4

Connecting the data and power cables

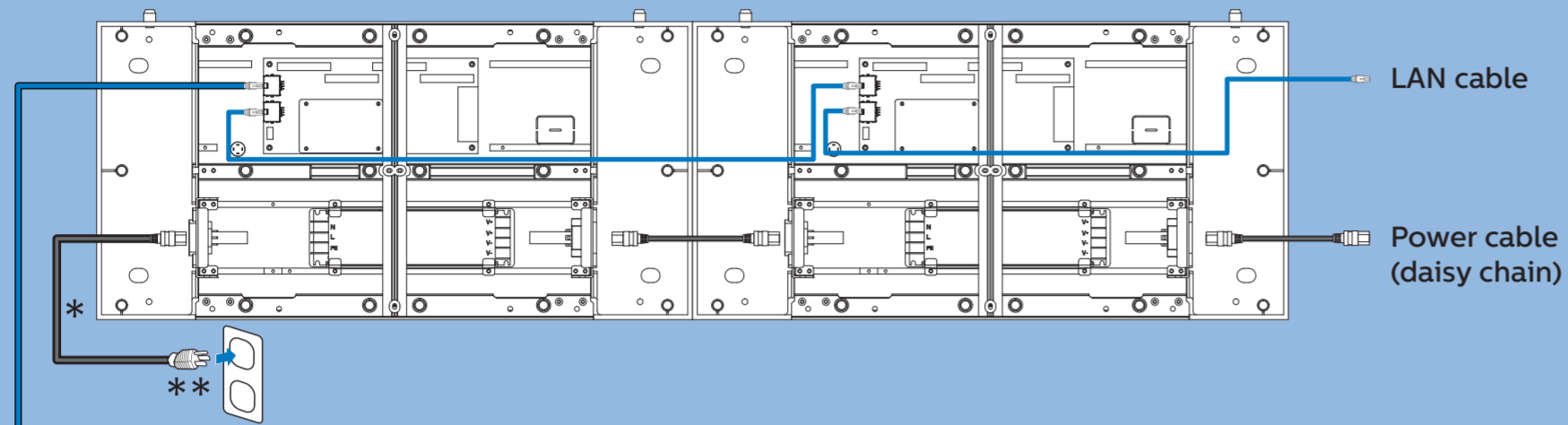

* optional accessories
 ** Power plug types vary by country/region.

LED display controller *

⚠ Plug the power plug into the electric outlet only when the cables are properly wired.
 Note: More cable wiring scheme and mounting scheme can be found in the User's Manual.

PHILIPS

Professional Display Solutions

L Line

22BDL72xxL
22BDL74xxL

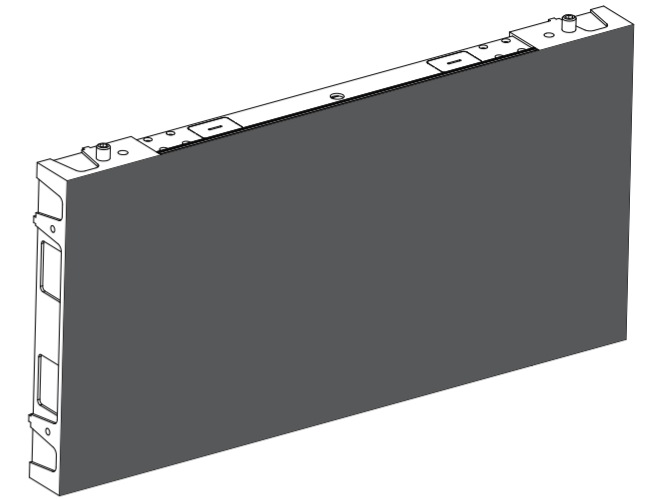

Quick Start



Please check out the website below for more product information.
https://www.philips.co.uk/p-m-pr/signage-solutions/latest#filters=L_LINE_SERIES_SU

5

Installing the LED modules

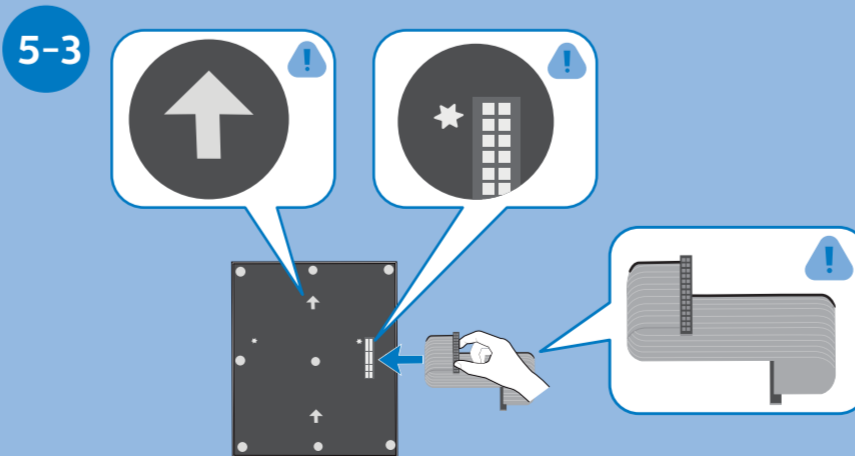
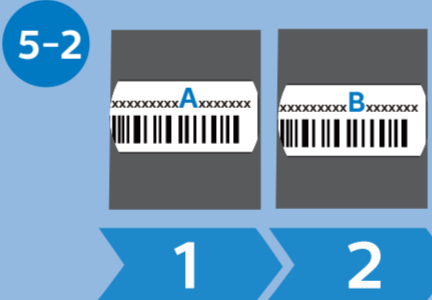
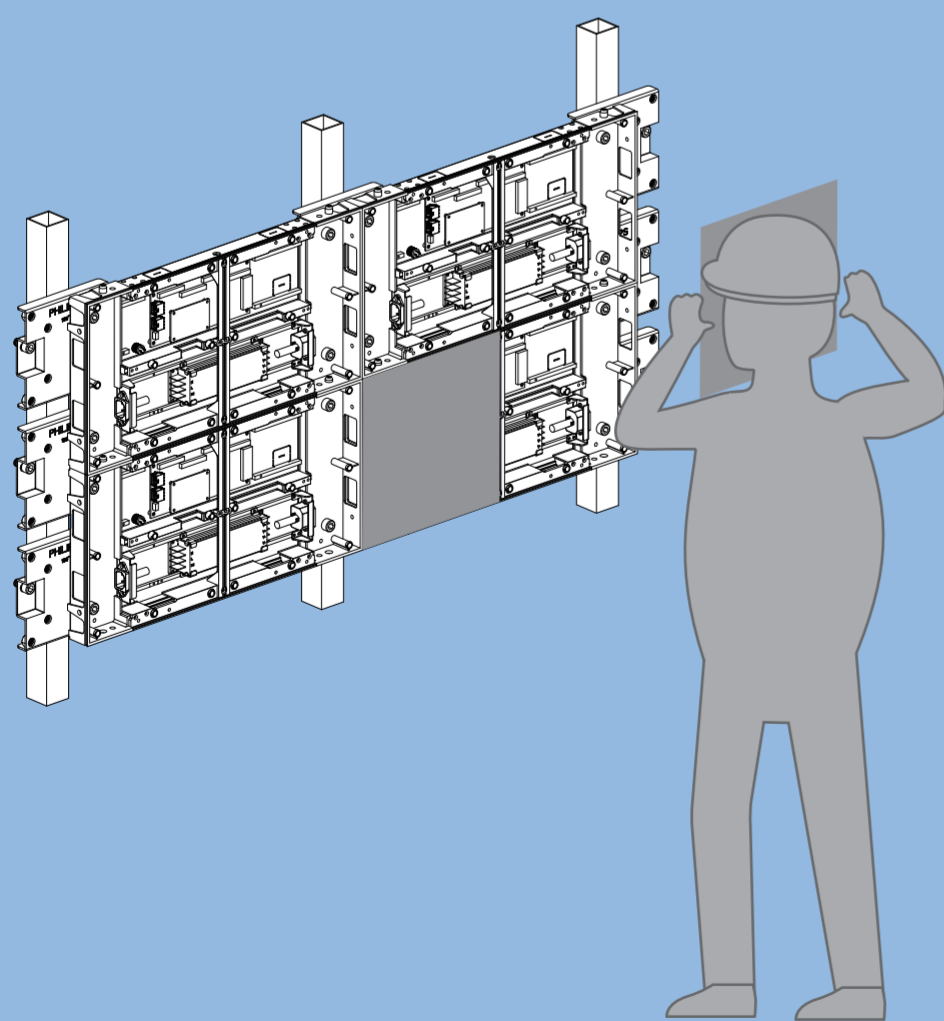

UK Authorized Representative
 UKCA Experts Ltd.
 Dept 302, 43 Owston Road Carcroft
 Doncaster, DN6 8DA United Kingdom

MMD Monitors & Displays Nederland B.V.
 Prins Bernhardplein 200
 1097 JB Amsterdam
 The Netherlands

Envision Peripherals Inc.
 490 N McCarthy Blvd, Suite #120
 Milpitas, CA 95035
 USA

2021 © TOP Victory Investments Ltd. All rights reserved.
 This product has been manufactured by and is sold under the responsibility of Top Victory Investments Ltd., and Top Victory Investments Ltd. is the warrantor in relation to this product. Philips and the Philips Shield Emblem are registered trademarks of Koninklijke Philips N.V. and are used under license.

Specifications are subject to change without notice.

Version: V1.00 2021-09-23



Q41G22MD81305A