

A4说明书 80克双胶纸 正反面黑色印刷

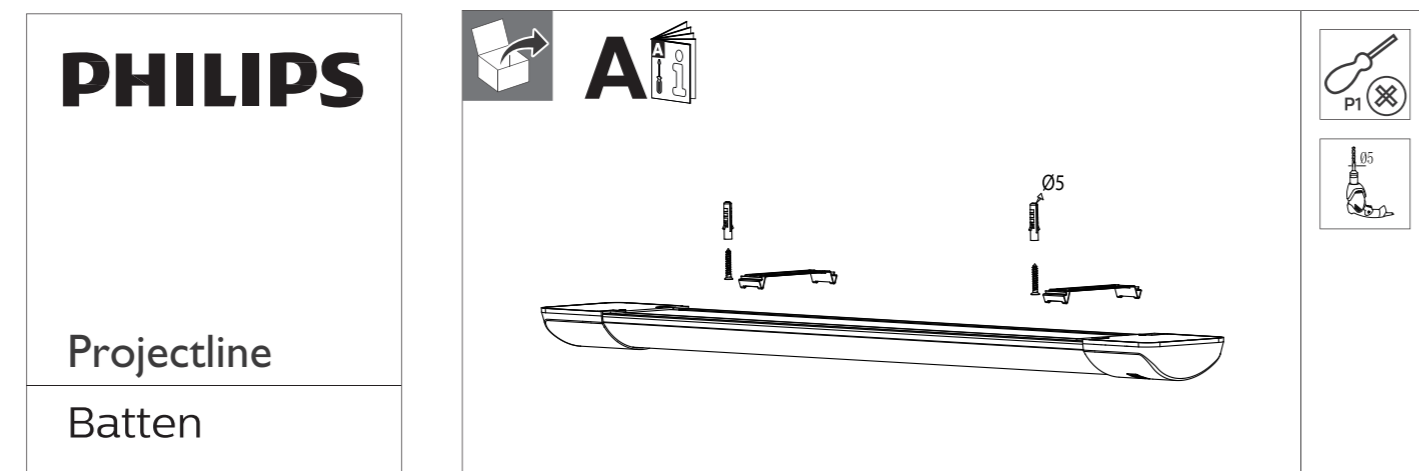

CE	UK CA	220V 240V	50Hz 60Hz	LEDs	Max. 40°C Min. -20°C	36,000
Type	System lumen (Lm)	CCT	P(W)	Energy efficiency class of light source	L	A
Projectline Batten 60 1440lm 3000K	1440	3000K	16W	F	600	255-385
Projectline Batten 60 1600lm 4000K	1600	4000K	16W	F	600	255-385
Projectline Batten 120 2700lm 3000K	2700	3000K	30W	F	1200	400-600
Projectline Batten 120 3000lm 4000K	3000	4000K	30W	F	1200	400-600

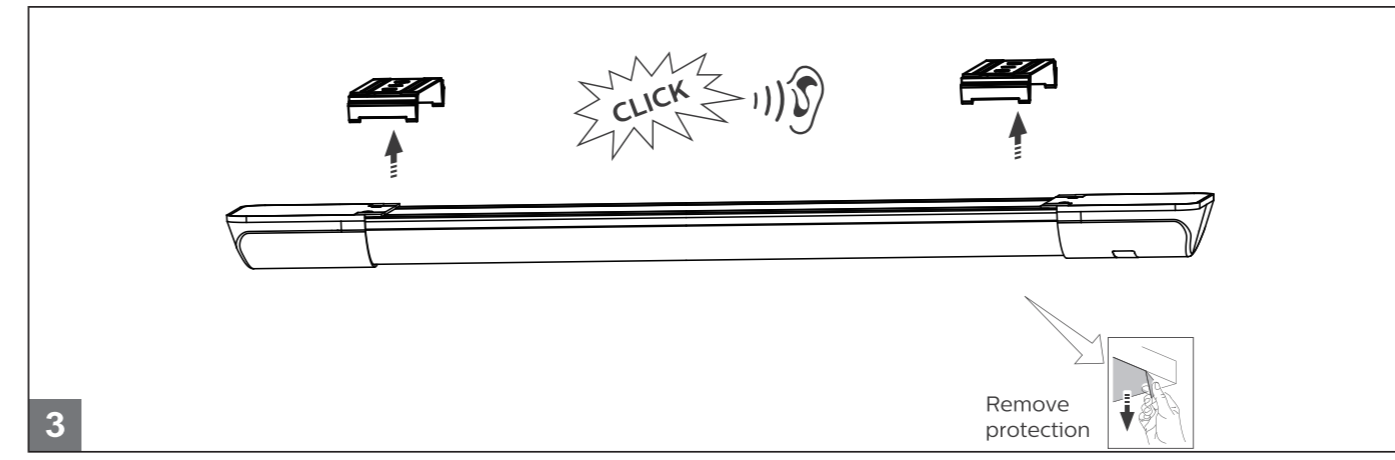
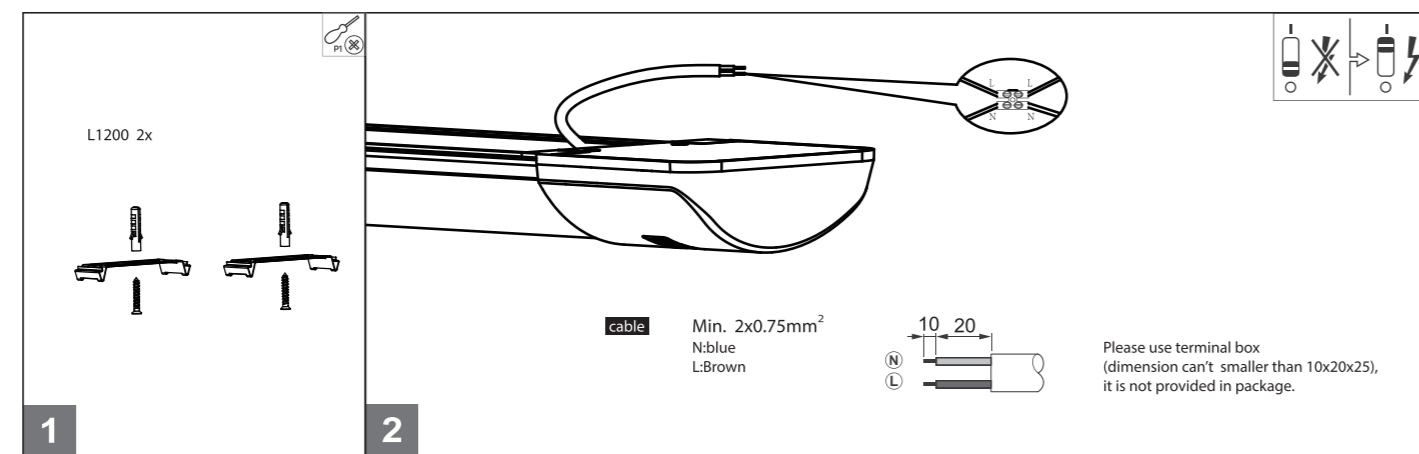
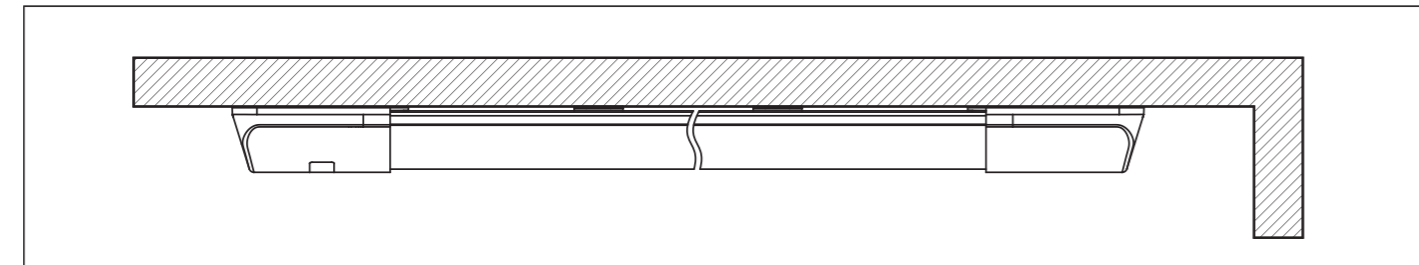
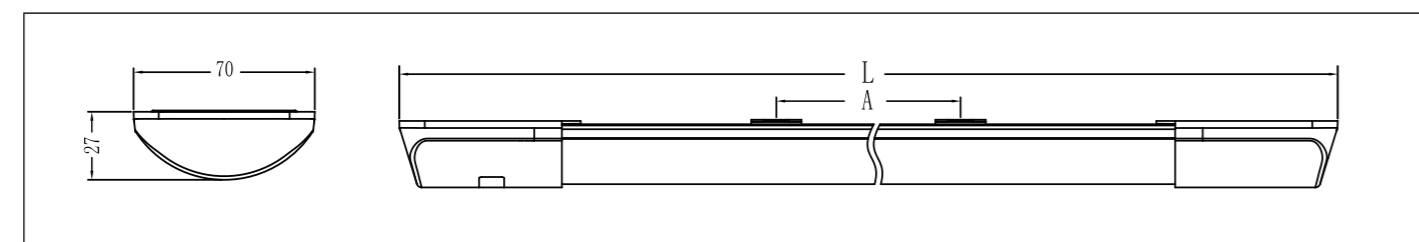

- The luminaire shall be installed by a qualified electrician and wired in accordance with the latest IEE electrical regulations or the national requirements.
 - The LED driver is not serviceable and not replaceable.
 - The light source contained in this luminaire shall only be replaced by the manufacturer or his service agent or a similar qualified person.
 - Luminaire must not be used or stored in corrosive environments where hazardous materials such as sulphur, chlorine, phthalates, etc. are present.
- ATTENTION
OBSERVE PRECAUTIONS
FOR HANDLING
ELECTROSTATIC
SENSITIVE
DEVICES