



**Stock No. 1020118**

**UL Listed and FM Approved**

**Dimensions:** 12-5/16" H x 8-5/16" W x 3-5/8" D  
31.2cm H x 21.1cm W x 9.2cm D

**Weight:** 8 lbs. (3.6 kg.)

**Enclosure:** 18GA CRS; Finish - Red enamel  
All ferrous metal parts painted, plated or  
the equivalent to resist corrosion.

**Switch Ratings:**

McCulloh Contacts — Limited Energy  
0.1Amp at 150VDC  
Tamper Switch — One set of SPDT contacts  
Rated 10.0 Amps at 250VAC

**Input Power:** 12-24V; 2 Watt Max.

**Frequencies:** DC or 60 Hz. AC

**Operating Distance:** ATTE-B must be within 3  
ft. of local control unit and wiring in conduit.

**Service Use:**

National Fire Alarm Code  
NFPA-72

- Central Station\*
- Proprietary\*
- Remote Station\*
- \*Protected Premise Unit

**Current Requirements:**

Normal position	9 mA
Trouble position	11 mA
Alarm position	11 mA
While transmitting	75 mA

The model ATTE-B is an electric motor driven McCulloh type transmitter which may be connected to a local NON-CODED type control unit to transmit CODED alarm and trouble signals. This alarm and trouble transmitter is suitable for Central Station, Proprietary and Remote Station protected premises services.

A shunt switch is provided so the unit may be used in a "Shunt Non-Interfering" arrangement.

The model ATTE-B is designed for 12 to 24 volt AC or DC operation.

**OPERATION:** Applying power to terminals 5 and 6 will cause the unit to transmit 1 round of the Coded Signal, illuminating the Yellow LED (TROUBLE INDICATION). After the

trouble condition in the Non-Coded Local Unit has been RESTORED, manually operate the Reset switch on the ATTE-B to restore the transmitter from the trouble position.

Applying power to terminals 3 and 4 will cause the unit to transmit 4 rounds of the Coded Signal if the unit is in the normal position and 3 rounds if the unit is in the trouble position, illuminating the Red LED (ALARM INDICATION).

Removing the power from terminals 3 and 4 will cause the ATTE-B to transmit 1 round Restore Signal automatically.

An adjustment on the circuit board provides transmitter motor speed adjustment from 1.25 to 3.5 code pulses per second.

**INSTALLATION (See Figs. 3 and 4):**

1. Mount ATTE-B.

**WARNING:** Wiring between non-coded control and ATTE-B is unsupervised. ATTE-B must be located within 3 feet of non-coded control with interconnect wiring in conduit.

2. **WARNING:** Code wheel must be removed, code cut and code wheel and bracket reinstalled before any power is applied to the transmitter. (See Fig. 1)
  - a. Remove code wheel and metal bracket under code wheel.
  - b. Cut code wheel to desired code.
  - c. Place hole in bracket over "P" emblem on underside of code wheel (recessed area - see Fig. 3). Reinstall code wheel and bracket. The bracket tab must be centered in the slot in black opto device (U8) on the circuit board (see Fig. 2).
  - d. Hold code wheel and bracket in this position and tighten mounting nut.
3. Apply power to terminals 7 and 8 (see note 3, Fig. 4). Transmitter will run to TROUBLE condition (yellow LED ON).

4. Pull tamper switch plunger to deactivate tamper. Operate reset switch. Transmitter will run 4 rounds to the NORMAL condition (yellow and red LED's OFF).
5. Connect alarm and trouble inputs, central office line, earth ground and shunt per Fig. 4.
6. Trip non-coded control to the ALARM condition. The ATTE-B will transmit a 4 round alarm signal and the red LED will come on. Restore non-coded control to the NORMAL condition. The ATTE-B will transmit a 1 round restore signal and return to the NORMAL condition (yellow and red LED's OFF).
7. Trip non-coded control to the TROUBLE condition. The ATTE-B will transmit a 1 round trouble signal and the yellow LED will come on.  
  
Restore non-coded control to the NORMAL condition. The ATTE-B will transmit 4 rounds and restore to the NORMAL condition (yellow and red LED's OFF).
8. Verify that the central office receives clear and intelligible signals.

**FIG. 1**

**CODE WHEEL REMOVAL AND CODING**

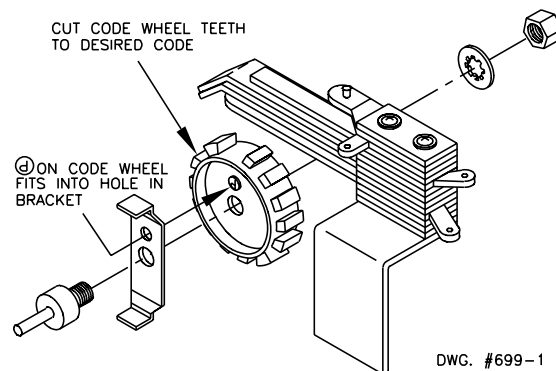

**FIG. 2** **ATTE-B 12 - 24V INSTALLATION**

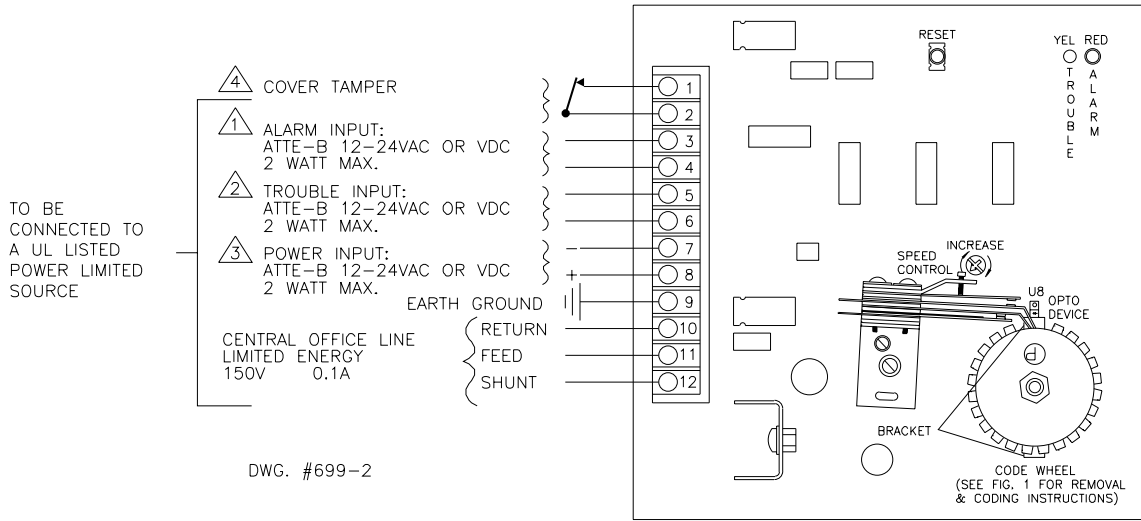

- 1 Apply voltage from non-coded control for 4 round alarm signal or 3 round signal if unit is in trouble condition.
- 2 Apply voltage from non-coded control for 1 round trouble signal.
- 3 Continuous power from non-coded control, or listed 12 - 24V Class II transformer in unswitched outlet.
- 4 Tamper - closed with cover in place.

**WARNING:** Transmitter should be tested on a monthly basis to insure proper operation. Code wheel must be removed, code cut and code wheel and bracket reinstalled before any power is applied to transmitter. Wiring between non-coded control and ATTE-B is unsupervised. ATTE-B must be within 3' of non-coded control and wiring in conduit.

**FIG. 3** **INSTALLATION WIRING INSTRUCTIONS**

The ATTE-B contains “Power Limited” fire protective signaling circuit conductors and Class 1 electric “Non-power Limited” circuit conductors.

The control unit enclosure provides multiple cable entry openings so that the “Power Limited” fire protective signaling conductors can be segregated from the Class 1 electric “Non-power Limited” conductors.

Enclosure cable entry opening in the top should be used for the Class 1 “Non-power Limited” conductors as the power inputs are located in this area.

The two bottom enclosure cable entries must be used for the “Power Limited” fire protective signaling conductors.

For specific wiring routing see Fig. 4.

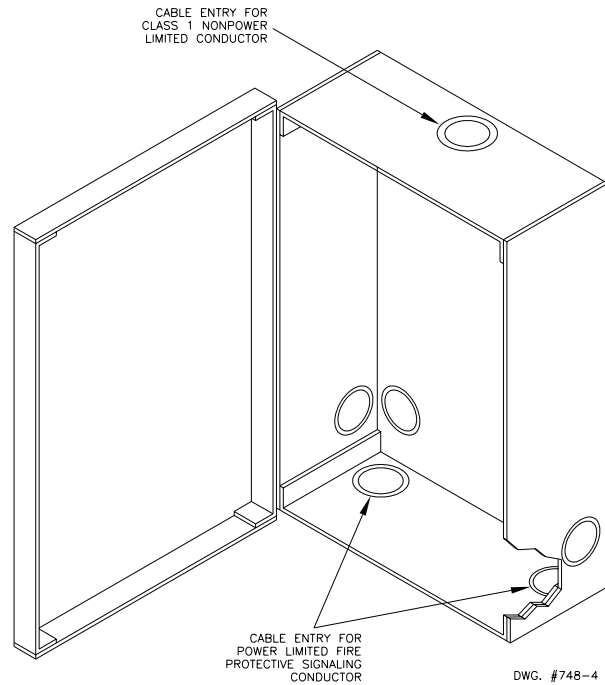

DWG. #748-4

**FIG. 4** **WIRE ROUTING**

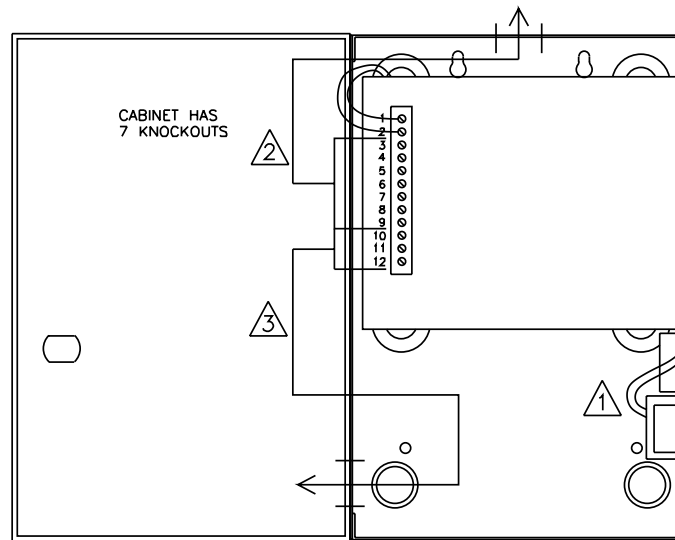

DWG. #699-3A

**ALL INPUT CIRCUITS MUST BE POWER LIMITED**

- 1 Cover tamper wire. Run under P.C. board to terminals 1 and 2.
- 2 Wires from terminals 3 through 9. Route through the top center knockout of cabinet.
- 3 Wires from terminals 10 through 12. Route through the lower left hand side of the cabinet.

**NOTE:** This unit does not have any output circuits other than the cover tamper circuit.