

# PRESTO precise.

## 17-Quart Digital Pressure Canner

Para instrucciones en español, escanee este código QR.

Si prefiere una copia impresa, puede descargar un PDF de nuestro sitio [www.GoPresto.com/espanol](http://www.GoPresto.com/espanol), enviar un correo electrónico a [contact@GoPresto.com](mailto:contact@GoPresto.com), o llamar al 1-800-877-0441.



Visit [www.PrestoPrecise.com](http://www.PrestoPrecise.com)

# INSTRUCTIONS AND RECIPES

Form 4120-004D  
©2025 National Presto Industries, Inc.

## TABLE OF CONTENTS

Important Safeguards . . . . .	2	Troubleshooting . . . . .	26
Getting Acquainted. . . . .	3	Error Codes . . . . .	26
Introduction . . . . .	4	Issues with Canned Food . . . . .	28
Canning Basics . . . . .	5	Frequently Asked Questions . . . . .	28
Preparation Steps Before Canning . . . . .	6	Cleaning . . . . .	30
Pressure Canning. . . . .	7	Care and Maintenance . . . . .	30
Tomatoes and Tomato Products. . . . .	9	Recipe Index . . . . .	31
Vegetables. . . . .	11	Consumer Service Information . . . . .	31
Meat, Game, Poultry, and Rabbit . . . . .	15	Warranty . . . . .	32
Fish and Seafood . . . . .	16		
Stock and Soup. . . . .	17		
Boiling Water Canning. . . . .	18		
Fruits . . . . .	20		
Tomatoes and Tomato Products. . . . .	23		
Jam, Jelly, and Soft Spreads . . . . .	25		
Pickles. . . . .	26		

**NOTICE:** This product is intended only for pressure canning and boiling water canning. Do not use it for cooking or preparing foods.





This is an ETL Listed appliance. The following important safeguards are recommended by most portable appliance manufacturers.

## IMPORTANT SAFEGUARDS

To reduce the risk of personal injury or property damage when using electrical appliances, basic safety precautions should always be followed, including the following:

1. Read all instructions. Improper use may result in bodily injury or property damage.
2. Before each use, check both the vent pipe (Fig. A, page 3) and vent filter (Fig. F, page 3) to be certain they are free of any blockage. Remove the filter and clean any debris from both the vent pipe and filter (see “Disassemble Canner Parts for Cleaning” instructions on page 3).
3. Always check the air vent/cover lock to be sure it moves freely before use.
4. To protect against electrical shock, do not immerse cord, plug, or canner body in water or other liquid.
5. Do not let children handle or put electrical cords or plugs in their mouths.
6. Always attach plug to appliance first, then plug cord into the wall outlet. To disconnect, press and hold  (the cancel button) for 3 seconds, then remove plug from wall outlet.
7. Unplug cord from unit and outlet when not in use and before cleaning. Allow unit to cool before putting on or taking off parts and before cleaning.
8. Do not operate any appliance with a damaged cord or plug or in the event the appliance malfunctions or has been damaged in any manner. Return the appliance to the Presto Service Department for examination, repair, or electrical or mechanical adjustment.
9. **WARNING!** Contents are hot and can cause serious burns. Keep appliance and cord away from children. Do not let cord hang over edge of counter or table, or touch hot surfaces.
10. To guard against electrical shock, can only in the removable pot provided.
11. The use of accessory attachments not recommended by the appliance manufacturer may cause injuries. Use only genuine Presto® accessories and replacement parts.
12. Intended for countertop use only.
13. Do not place on or near a hot gas or electric burner, or in a heated oven.
14. This appliance operates under pressure. Improper use may result in scalding injury. Make certain canner is properly closed before operating (see step 14 on page 8 or step 16 on 19).
15. Do not attempt to open the canner until all internal pressure has been released and the air vent/cover lock has dropped. Any pressure in the canner can be hazardous. Never force open the temperature sensor arm.
16. Extreme caution must be used when moving a canner containing hot liquids. Do not touch hot surfaces. Always use appliance handles.
17. To ensure safe operation and satisfactory performance, replace the sealing ring, air vent/cover lock gasket, and sensor gasket if they become hard, deformed, cracked, or torn. Use only genuine Presto® replacement parts.
18. Close supervision is necessary when the canner is used near children. It is not recommended that children use the canner.
19. Do not use this appliance for other than intended use.
20. Do not use this appliance for deep fat frying.
21. Do not use outdoors.

## SAVE THESE INSTRUCTIONS

THIS APPLIANCE IS FOR HOUSEHOLD USE ONLY.

### IMPORTANT CORD INFORMATION

To reduce the risk of electric shock, this appliance has a 3-prong grounded plug. If the plug on this appliance does not fit into your outlet, contact a qualified electrician. Do not attempt to modify the plug in any way.

A detachable power supply cord is provided. An extension cord may be used if care is properly exercised in its use.

If an extension cord is used, it should be a 3-wire grounded type cord, marked with a minimum electrical rating of 13 amps, and be no longer than 10 feet. The extension cord should be arranged so that it will not drape over the countertop or tabletop where it can be pulled on by children or tripped over unintentionally.

Connect the power supply cord to a 120VAC electrical outlet only.

## GETTING ACQUAINTED

As received, your digital canner will be fully assembled. Disassemble and clean the canner parts (Fig. A) as directed below. Read all instructions carefully. If you are new to canning or need some refresher training, refer to the “Canning Basics” section on pages 5 and 6.

### Perform “WATER TEST” before first use.

To help yourself understand the operation of the pressure canner, practice first with jars of water instead of jars of food. Lids and bands are not needed on the jars.

Follow the step-by-step instructions for Pressure Canning (page 7–9) and for Boiling Water Canning (pages 18–19), beginning with step 3. Pour 3 quarts of hot tap water into the pot, up to the fill line.

### Remove the Canner Cover

1. Before removing the cover, you will need to unlock the green latch. Begin by positioning the canner so the digital display faces you. To unlock the latch, grasp the sides of the latch and turn it counterclockwise until it stops (Fig. B). Lift the temperature sensor arm out of the sensor hole in the cover (Fig. C).
2. Once you have released the temperature sensor arm from the cover, rotate the cover counterclockwise until the *INSTALL/REMOVE* vertical mark is within the **□** mark on the canner body (Fig. D). Then lift the cover straight up off the canner body.

### Disassemble Canner Parts for Cleaning

It is recommended that the canner parts be thoroughly washed before first use to remove any manufacturing residue.

1. Take the sealing ring assembly off the removable pot rim (Fig. A). Then, lift the canning rack and removable pot out of the canner body.
2. Detach the sealing ring from the metal frame (Fig. E).
3. Remove the vent filter for cleaning. To remove the filter, place the inverted cover on the counter, then rest a table knife on the rim of the cover and insert the knife tip into one of the filter slots (Fig. F); gently lift the filter up.

**NOTE:** Although you will not need to remove the filter after every use, you should periodically remove it for cleaning if it appears dirty or contains debris.

Fig. A

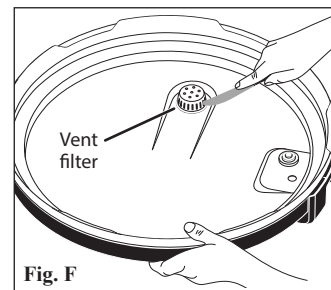
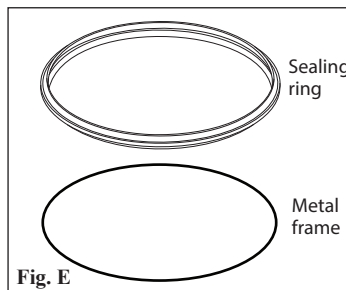
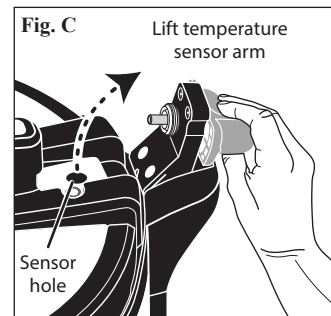
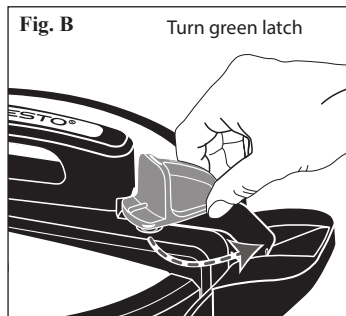
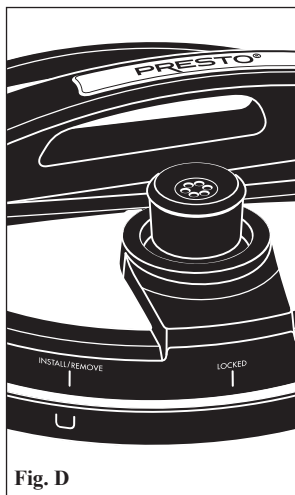
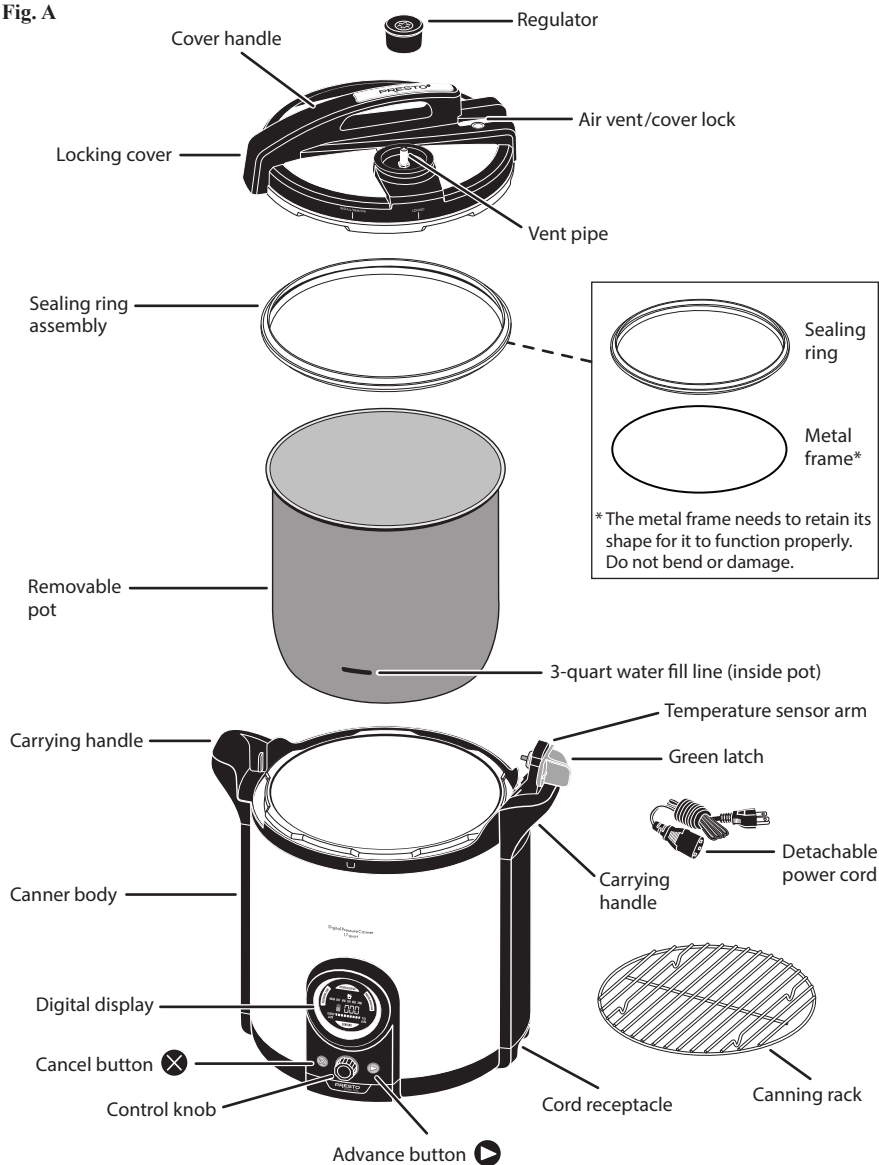

- Wash the sealing ring, metal frame, vent filter, canning rack, and removable pot in warm, soapy water. Rinse and dry thoroughly. The canning rack is dishwasher safe. **Do NOT wash any of the other parts in the dishwasher.**
- Clean the canner cover with a damp, soapy cloth. **Do NOT immerse the canner cover in water or wash it in the dishwasher.**

**CAUTION!** To prevent electrical shock and damage to the canner, never pour water into the canner body or immerse it or the power cord in water. Always be sure the pot is **COMPLETELY DRY** before placing it back in the canner body.

- After cleaning the cover, reattach the vent filter. Be sure to place the vent filter over all 3 clips (Fig. G), then push it into place. If placed correctly, you will hear a snap as the clips grip the filter. The filter should fit tightly.

- Reattach the sealing ring to the metal frame. Use your thumbs and index fingers to gently push it around the frame. The sealing ring is properly positioned when the metal frame is seated in the ring's inner groove.

**IMPORTANT:** The sealing ring assembly must be on the removable pot rim when canning (Fig. H).

To watch a video demonstrating how to install the sealing ring and position the sealing ring assembly on the removable pot, scan this QR code.

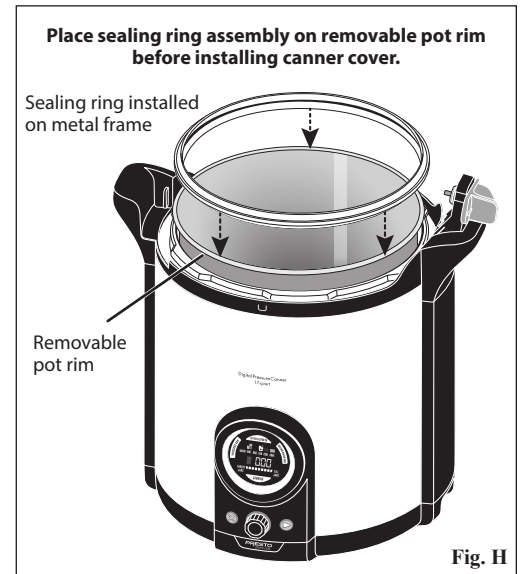
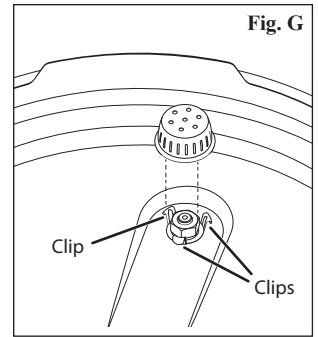

## INTRODUCTION

The Presto Precise® Digital Pressure Canner is both a pressure canner and boiling water canner in one. Use the control knob to set the desired canning method. The LED display icons will then guide you through each step of the process.

Each time you use the canner, complete the preparation steps on pages 6 and 7. Then follow the instructions for **Pressure Canning** (pages 7–9) or for **Boiling Water Canning** (pages 18–19).

There is no altitude adjustment necessary when pressure canning; however, when using the boiling water canning method, you must increase the processing time. Refer to the altitude chart on page 20 for recommended times.

Mason Jar Capacity				
Maximum capacity may vary depending on jar styles. Do not force jars to fit.				
JAR TYPE	PRESSURE CANNING		BOILING WATER CANNING	
	Regular mouth	Wide mouth	Regular mouth	Wide mouth
Half-pints*	19**	13**	10	7
Pints	8	13**	8	7
Quarts	5	5	5	5

\*To properly **pressure can** half-pint or smaller jars, it may be necessary to raise the rack off the bottom of the removable pot so the jars are not fully immersed in the water. To do this, place three screw bands in the bottom of the removable pot and set the rack on top of the bands (Fig. I).

\*\*It will be necessary to double-deck half-pint and pint jars to achieve maximum jar capacity. Stagger the jars by placing one jar on top of two (Fig. J). Jars may touch.

**NOTE:** No minimum number of jars are required.

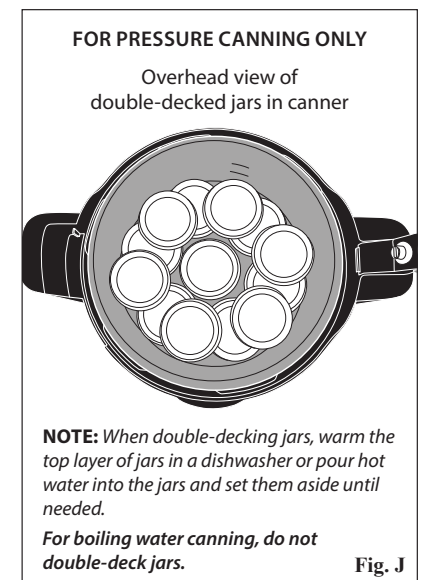
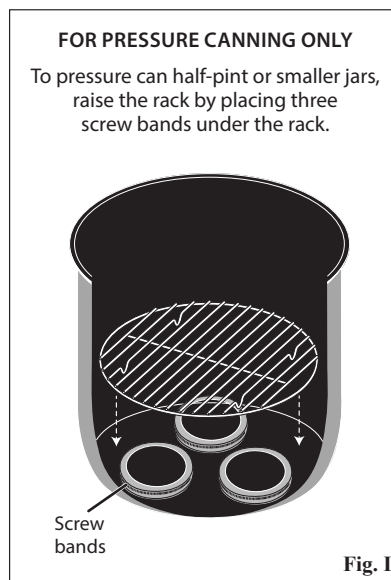

## CANNING BASICS

Canning is a process that enables the user to keep fruits, vegetables and meat for extended periods without refrigeration or freezing. Normally, if left out, these foods would spoil. Canning interrupts the natural spoilage cycle so food can be preserved safely.

There are invisible microorganisms present all around us and in our food that cause spoilage. Spoilage is nature's way of telling us when food is no longer fit to eat. There are four basic agents of food spoilage—enzymes, mold, yeast, and bacteria. The first three—enzymes, molds, and yeast—are destroyed at temperatures below 212°F, the temperature at which water boils (at sea level). Therefore, boiling water canning is sufficient to destroy those agents.

Foods naturally high in acid and acidified foods having a pH of 4.6 or less may be safely processed using the boiling water canning method. **Step-by-step instructions for Boiling Water Canning begin on page 18.**

Bacteria, however, are not as easily destroyed. The bacteria *Clostridium botulinum* produces a spore that makes a poisonous toxin which causes botulism. This spore is not destroyed at 212°F. In addition, the bacteria thrive on low-acid foods in the absence of air. According to the United States Department of Agriculture (USDA), pressure canning is the only safe method of processing low-acid foods (vegetables, meats, poultry, fish, and seafood).

In pressure canning, some of the water in the canner is converted to steam, which creates pressure within the canner. This pressure is what allows the canner to reach temperatures above boiling. At 240°F, this pressurized heat destroys the potentially harmful bacterial spores. **Step-by-step instructions for Pressure Canning begin on page 7.**

As jars cool after processing (by either the boiling water or pressure canning method), a vacuum is formed, sealing food within and preventing any new microorganisms from entering and spoiling the foods.

### *Before Beginning*

#### Selecting a Recipe

To produce home-canned food that is safe for storage at room temperature, it is necessary to use a tested canning recipe. Recipes that have been handed down through the years or those found on the web are oftentimes unreliable and usually do not include the scientifically-tested processing procedures vital to a successful and safe canning project. Canning information published prior to 2015 may be incorrect and could pose a serious health risk. A tested canning recipe has been evaluated to determine the accurate processing method (boiling water canning or pressure canning) as well as the processing time. Do NOT can leftovers; it is not safe.

Always choose recipes from a reliable resource, such as the National Center for Home Food Preservation ([nchfp.uga.edu](http://nchfp.uga.edu)), your local Cooperative Extension Service, or this instruction book.

#### Selecting Jars

Glass home canning jars, sometimes referred to as Mason jars, are the only jars recommended for safe home canning. They can withstand the heat of a pressure canner, are durable, and can be reused time after time. They are available in standard sizes (half-pint, pint, and quart jars) and other non-standard sizes. The diameter of Mason jars may vary from one manufacturer to another.

When canning with a research-tested recipe, a smaller jar size may be used than what is specified in the recipe. However, you must follow the processing time for the smallest jar size listed in the recipe. Never use a larger jar than what is listed.

The canning rack which accompanied your canner must be placed on the bottom of the removable pot to prevent jar breakage. To pressure can small jars, the rack may need to be raised so the jars are not fully immersed in the water (see page 4). Although it is not necessary to use a rack between layers of jars, if you wish to do so, a rack can be ordered from the Presto Consumer Service Department (see page 31).

Before filling Mason jars, test load your canner. When pressure canning, it will be necessary to double-deck half-pint and pint jars to reach the maximum capacity, as indicated in the chart on page 4. To double-deck, stagger the jars by placing one jar on top of two (Fig. J, page 4). Jars may touch. **Do not double-deck jars for the boiling water canning method.**

#### Canning Lids and Screw Bands

The two-piece vacuum cap (lid and screw band) is the recommended closure for home canning. It consists of a flat metal lid with a sealing compound on the outer edge and a separate metal screw band that secures the lid during processing. The flat lid is for one use only, while the bands can be used repeatedly if they remain in good condition. Do not use dented or rusty bands. Use only jars, lids, and screw bands in perfect condition so an airtight seal may be obtained. Bands should be removed prior to storage.

#### Measuring Headspace

Headspace is the air space between the top of the food or its liquid and the lid. Leaving too much headspace can result in underprocessing because it may take too long to release the air from the jar. Leaving too little headspace will trap food between the jar and the lid and may result in an inadequate seal. As a general rule, allow ¼-inch headspace for jams and jellies; ½-inch for fruits and tomatoes; 1-inch for vegetables, meats, and seafood; and 1¼-inch for poultry. All recipes will indicate the amount of headspace necessary for the food being canned.

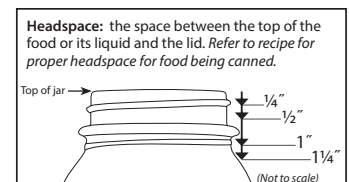

## Removing Air Bubbles

After food has been packed in jars, any air bubbles must be removed. Trapped air bubbles may rise to the top during processing, causing too much headspace. Work quickly to remove air bubbles that have become trapped between the pieces of food by moving a clean, nonmetal spatula around the jar between the food and side of the jar.

## Preparing Jar Rims and Adjusting Lids and Screw Bands

Immediately after filling, wipe jar rims with a clean, damp cloth to remove any residue. Any food particles, such as seeds, grease, or syrup, on the rim of the jar may prevent the jar from sealing. Center a flat lid on the jar rim, making sure the sealing compound is touching the glass. Position a band over the lid and, using your fingertips, screw it onto the jar evenly and firmly (fingertip tight). Do not overtighten as air must release from the jars during processing and cooling.

## Other Special Canning Tips

To help prevent mineral deposits on the canning rack and jars, add 1 teaspoon cream of tartar or 2 tablespoons white vinegar to water in the removable pot.

## After Processing

### Cooling Jars

After processing, remove jars to a dry towel on countertop away from drafts. Leave 1 to 2 inches of space between jars to allow for even cooling. Do not retighten bands. Do not invert jars or cover with a cloth. Allow jars to cool naturally. Check seals no earlier than 12 hours, but no later than 24 hours.

Bubbles often appear in the jar after removal from the canner because food is still boiling in the jar. Ordinarily bubbles do not appear once the product has been allowed to thoroughly cool.

### Testing Seals and Storing Canned Food

After jars have cooled a minimum of 12 hours, but no more than 24 hours, test the jar lids to be sure a vacuum seal has formed. Press down on the center of the flat lid to determine if it is concave (stays down when pressed). Remove the screw band and gently try to lift the lid with your fingertips. If the center does not flex up and down and you cannot lift the lid off, the lid has a good seal. Wipe off any food residue from jars and lids. Date and label jars. Store in a cool, dark, and dry place.

If a jar does not seal, the food can be refrigerated and should be used within 3 days. Other options include freezing the food or reprocessing for the full amount of time per the canning recipe. If choosing to reprocess, remove the lids and reheat the food and/or liquid. Pack food into clean, heated jars. Remove air bubbles and clean jar rims. Position new lids on jars and secure with bands. **If more than 24 hours have elapsed since the canner registered DONE, and the seal is faulty, the food is no longer safe. Discard at once.**

To watch a video demonstrating how to test the seals on jars, scan this QR code.



### Detecting Spoilage

If up-to-date instructions and processing times are followed carefully, spoilage is uncommon. However, it is still recommended to check for signs of spoilage before tasting any canned food. Check for a broken seal, gassiness when opening, mold, sliminess, cloudiness, or unpleasant odors. If any of these signs are present, discard the food. As a safeguard against using canned low-acid and tomato products which may be affected with spoilage that is not readily detected, boil food 10 minutes for altitudes up to 1,000 feet above sea level. Extend the boiling time by 1 minute for each 1,000 foot increase in altitude. Many times odors that cannot be detected in the cold product will become evident by this method. If, after boiling, food does not smell or look right, **discard it without tasting.**

## PREPARATION STEPS BEFORE CANNING

In order for the unit to function properly, **always** follow these instructions before each use:

- Place the electric canner on a dry, level surface. Always place a protective heat-resistant material (such as a large cutting board) between the canner and the countertop surface to avoid heat damage. To prevent steam damage to cabinets, position the canner so the vent pipe and air vent/cover lock are not directly under cabinets.

**WARNING!** A fully loaded canner can weigh in excess of 56 pounds. To avoid damage to the counter, always place the canner on a surface that supports the weight of a fully loaded canner, such as the center of a kitchen counter or table. **DO NOT** place a canner near the edge of a surface or on an overhang.

- Be sure the bottom of the removable pot and the heating plate within the canner body (Fig. K) are free of debris before placing the pot in the canner body.

**CAUTION!** To prevent electrical shock and damage to the canner, **NEVER USE THE UNIT WITHOUT THE REMOVABLE POT.** Also, be sure the outside of the pot is **COMPLETELY DRY** before placing it into the canner body.

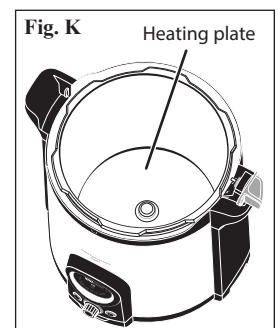

- Check both the vent pipe and vent filter to be sure they are clear and do not contain any debris. In order to check the vent pipe, you will need to remove the regulator from the cover (Fig. A, page 3). Then hold the cover up to a light and make sure you can see light coming through the vent pipe. If you cannot, remove the vent filter (see page 3) and clean the vent pipe with a small brush or pipe cleaner to remove the blockage. Reattach the vent filter to the cover.
- Ensure the sealing ring is properly positioned on the metal frame. Also, verify the sealing ring assembly is seated on the removable pot rim before installing the canner cover (Fig. H, page 4).
- Always make sure the gasket is positioned on the sensor (Fig. L).
- Check Mason jars for nicks, cracks, and sharp edges. Check screw bands for dents or rust. Use only jars, lids, and screw bands in perfect condition so an airtight seal may be obtained.
- Wash and rinse jars, lids, and screw bands. Follow closure manufacturer’s directions for preparing lids.

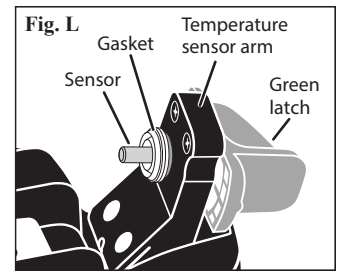

**Perform “WATER TEST” before first use.**

To help yourself understand the operation of the pressure canner, practice first with jars of water instead of jars of food. Lids and bands are not needed on the jars.

Follow the step-by-step instructions for pressure canning, beginning with step 3 below. Pour 3 quarts of hot tap water into the pot, up to the fill line.

**PRESSURE CANNING**

**I. GETTING READY**

1. Complete “Preparation Steps Before Canning” on page 6 and at the top of this page. Select the pressure canning recipe (see pages 10–17 or use a tested canning recipe) and gather the needed supplies.

2. Begin preparing the food that will be used for filling the jars in step 12.

**NOTE:** Any food that is described in a recipe as “Hot Pack” should be freshly prepared or, if made in advance, it should be reheated as instructed in the canning recipe.

3. Place the removable pot in the canner body. Put the canning rack in the pot, feet side down.\*

**NOTE:** Jars will be placed on the rack in step 7. If set directly on the bottom of the pot, jars may break.

4. Pour 3 quarts of hot tap water into the pot, up to the fill line (Fig. A, page 3).

**Tip:** To help prevent mineral deposits on the canning rack and jars, add 1 teaspoon cream of tartar or 2 tablespoons white vinegar to the water in the pot.

**NOTE:** 3 quarts of hot tap water are needed regardless of how many jars are being canned.

5. Attach the power cord to the canner body, making sure to fully insert it in the receptacle. Then plug into a 120VAC wall outlet. The default icon **PRESSURE CAN** will flash in the display window (Fig. M).

Press the control knob to select the **PRESSURE CAN** mode. The **PRESSURE CAN** icon will remain illuminated for the duration of the canning process.

6. Rotate the knob to set the time for the specific canning recipe and jar size being used. The time adjusts in 5-minute increments up to 180 minutes.

**IMPORTANT:** Verify you have set the right program and time.

**NOTE:** If the **BOILING WATER CAN** program is accidentally selected, or the wrong time is entered, press and hold **⊗** for 3 seconds. The **PRESSURE CAN** icon will flash. Press the control knob and repeat step 6.

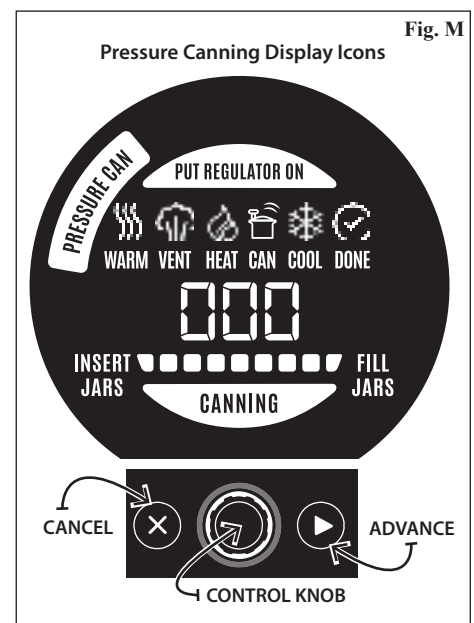

\*If pressure canning half-pint or smaller jars, it may be necessary to raise the rack off the bottom of the removable pot so the jars are not fully immersed in the water. To do this, place three screw bands in the bottom of the removable pot and set the rack on top of the bands (Fig. I, page 4).

## II. JAR WARMING

INSERT  
JARS

7. Press . **INSERT JARS** will light up. Fill the canning jars half full with hot tap water and place them on the canning rack.
8. Position the sealing ring assembly on the removable pot rim (Fig. N).
9. **REMOVE THE REGULATOR** if it is on the canner cover. It will not be needed until step 16 of the venting phase.
10. Place the cover on the canner body, aligning the *INSTALL/REMOVE* vertical mark within the mark on the canner body (Fig. D, page 3). Rotate the cover clockwise until it stops. The canner cover is properly installed when the *LOCKED* vertical mark is within the mark on the canner body (Fig. O).

Keep the temperature sensor arm in the upright, unlocked position.

WARM

11. Press . **WARM** will light up and the progress bar will begin scrolling from left to right, indicating the unit is heating.

Jar warming will take about 20 minutes. During this time, complete any necessary food preparation.

## III. FILL JARS

FILL  
JARS

12. When the canner beeps twice and **FILL JARS** lights up, the jars are preheated and ready for filling. The canner will continue to keep the jars warm until you are ready to fill them. Unlock and remove the canner cover. Lift the cover toward you to keep any steam away from you.

Remove one jar at a time from the canner; discard the water from the jar. Immediately fill the jar with food and liquid, according to the specific tested recipe. Remove air bubbles by moving a clean, nonmetal spatula around the jar. Clean the jar rim with a damp cloth. Center a flat lid on the jar rim, making sure the sealing compound is touching the glass. Position a band over the lid and, using your fingertips, screw it onto the jar evenly and firmly (fingertip tight). Do not overtighten as air must release from the jars during processing and cooling. Place the jar on the canning rack promptly after filling.

Repeat the above procedure for each jar.

## IV. VENTING

HEAT

13. Verify the sealing ring assembly is on the removable pot rim (Fig. N).
14. Place the cover back on the canner and lock it on. Lower the temperature sensor arm and insert the sensor into its hole in the cover (Fig. O). It may be necessary to rotate the cover slightly so the hole aligns with the sensor. Then, grasp the green latch and, using a slight downward pressure, turn the latch clockwise until it aligns with the handle (Fig. P).

**IMPORTANT: Confirm the regulator is not on the cover.**

Press and **HEAT** will light up.

VENT

15. Once the proper temperature is reached, the canner will proceed to the vent phase; **VENT** and will light up. The venting timer will begin counting down.

During venting, air/steam will release from the vent pipe and air vent/cover lock. This will be noticeable. You will hear boiling throughout the venting and canning phases.

Depending on the number and size of the jars, the air vent/cover lock may lift during venting. The smaller the load, the more likely the air vent/cover lock will lift.

16. When the time expires, the unit will start beeping and **PUT REGULATOR ON** will light up. Place the regulator on the vent pipe (Fig. Q). The regulator will fit loosely on the vent pipe. Press to advance to the canning phase. The beeping will stop.

PUT REGULATOR ON

If the air vent/cover lock did not lift during venting, air/steam will continue to release from the air vent/cover lock until it lifts (Fig. R).

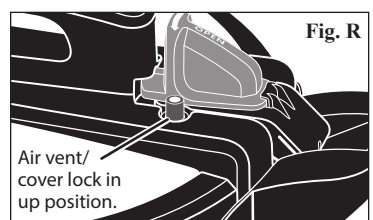
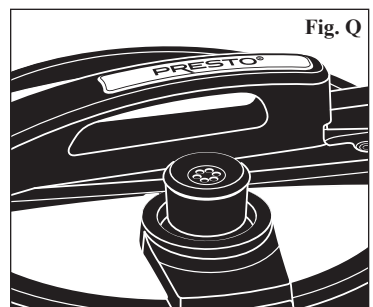
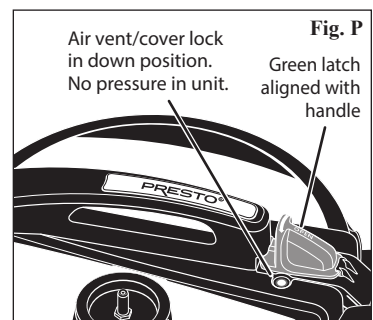
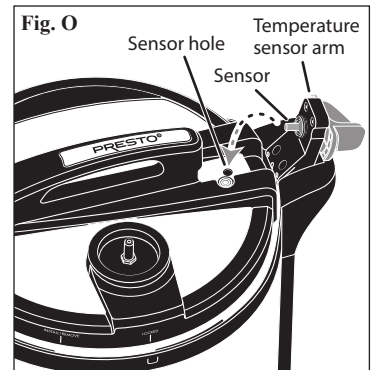
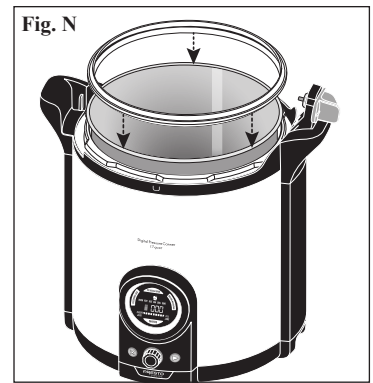

## V. CANNING



17. **CAN** will light up and the processing time programmed in step 6 will appear in the display. The progress bar will continue to scroll as the canner heats.

**NOTE:** In the event an incorrect processing time was entered, see *Frequently Asked Questions #1* on page 28.



18. Once the required canning temperature is reached, the unit will beep twice and **CANNING** will light up. The canner is now processing and the timer will start to count down. The progress bar will stop scrolling and begin to light up in segments, increasing in length as the processing time counts down (e.g., if 15 minutes of a 20 minute processing time have elapsed, 75% of the bars will be illuminated).

## VI. COOLING



19. When the processing time expires, the canner will beep 4 times and **COOL** will light up. This is the final canning phase. The length of the cool-down period will depend on the canner load and may take about 1½ hours.

 will light up in the display. The unit will start to count down when cooling is almost done. The progress bar will scroll from right to left to indicate the unit is cooling.

## VII. DONE



20. When the time expires, the unit will beep 10 times and **DONE** will light up. Press and hold  for 3 seconds. If the air vent/cover lock remains in the up position when the display indicates **DONE**, wait for it to drop.

Remove the regulator, unlock the green latch, and lift the temperature sensor arm. Then unlock and remove the canner cover. Lift the cover toward you to keep any steam away from you.

21. Using a jar lifter, remove jars by lifting them straight up. Be careful not to tilt the jars, which causes liquid to siphon out. Food particles may also get between the jar rim and the lid and prevent the jar from sealing. Place jars upright on a board or dry towel, away from drafts. Do not retighten bands.

Allow jars to cool naturally. Check seals no earlier than 12 hours, but no later than 24 hours. See page 6 for “After Processing” information.

22. **When processing consecutive batches:** Before warming the next batch of jars, allow the water in the canner to cool or replace with 3 quarts of fresh hot tap water. **NOTICE:** Placing jars immediately in the water from the previous batch can result in thermal shock to the glass jars that may in turn cause cracks and breakage.

If reusing the water, check the water level in the canner. Add water, if necessary, to keep water at the 3-quart fill mark (Fig. A, page 3).

23. To can additional jars, repeat steps 6 to 22.

24. When canning is complete, unplug the cord from the wall outlet and then from the canner base. Allow canner to cool completely, empty water from removable pot, and clean according to the instructions on page 30.

## PRESSURE CANNING *Tomatoes and Tomato Products*

Tomatoes and tomato products may be safely processed using the boiling water canning method or pressure canning method. However, for some tomato products, the pressure canning method may result in a more nutritious canned product. (For boiling water canning instructions, see page 23).

### Acidifying Tomatoes and Tomato Products

Tomatoes have a pH close to 4.6, which means it is necessary to take precautions to can them safely. First, carefully choose the tomatoes for canning. Use only tomatoes that are disease-free, preferably vine-ripened, and firm.

Second, an acid must be added to tomatoes whether they are processed using the boiling water canning method or pressure canning method. To ensure the safety of whole, crushed, or juiced tomatoes, add 1 tablespoon bottled lemon juice (not natural juice) or ¼ teaspoon citric acid per pint jar; for quarts, add 2 tablespoons bottled lemon juice or ½ teaspoon citric acid.

### Salt

Tomatoes and tomato products may be canned with or without salt. Salt is used only for flavor, as it is not used in a large enough quantity to prevent spoilage. If salt is desired, use only canning or pickling salt. Table salt contains anti-caking agents that may cause cloudiness in the liquid inside the jars.

The recommended amount of salt is ½ teaspoon for each pint jar, 1 teaspoon for each quart jar.

**Tip:** Dried herbs and spices can safely be added to a tested canning recipe.

## PRESSURE CANNING RECIPES: TOMATOES

### TOMATOES—WHOLE OR HALVED (packed in water)

Wash smooth, firm, ripe tomatoes. Loosen skins by dipping tomatoes 1 minute in boiling water, then in cold water. Peel and remove core. Leave whole or halve, or if using large tomatoes, quarter.

**Hot Pack:** Place prepared tomatoes in a large pot and add just enough water to cover. Bring to a boil and boil gently for 5 minutes. Add bottled lemon juice or citric acid to hot jars (page 9). Add salt, if desired (page 9). Pack hot tomatoes in hot jars, leaving ½-inch headspace. Fill jars with hot cooking liquid, leaving ½-inch headspace. Remove air bubbles. Clean jar rims. Position lids and secure with bands.

**Raw Pack:** Add bottled lemon juice or citric acid to hot jars (page 9). Add salt, if desired (page 9). Pack prepared tomatoes in hot jars, leaving ½-inch headspace. Fill hot jars with boiling water, leaving ½-inch headspace. Remove air bubbles. Clean jar rims. Position lids and secure with bands.

**Pressure canning:** Process pints and quarts 10 minutes.

### TOMATOES—WHOLE OR HALVED (packed raw without added liquid)

Wash smooth, firm, ripe tomatoes. Loosen skins by dipping tomatoes 1 minute in boiling water, then in cold water. Peel and remove core. Leave whole or halve.

***NOTE:** Tomatoes that are raw packed will separate during processing into a liquid and solid, with the solids forming on top of the liquid. This is due to an enzyme that causes tomatoes to break apart when heated. Flavor and nutritional quality are not affected by this change.*

Add bottled lemon juice or citric acid to hot jars (page 9). Add salt, if desired (page 9). Fill jars with raw tomatoes, pressing until spaces between them fill with juice. Leave ½-inch headspace. Remove air bubbles. Clean jar rims. Position lids and secure with bands.

**Pressure canning:** Process pints and quarts 25 minutes.

### TOMATO JUICE

Wash ripe, juicy tomatoes. Remove stem ends and trim off bruised or discolored portions. To prevent juice from separating, quickly cut about 1 pound of tomatoes into quarters and put directly into a large pot. Heat immediately to boiling while crushing. Continue to slowly add and crush freshly cut tomato quarters to the boiling mixture. Make sure the mixture boils constantly and vigorously while adding more tomatoes. Simmer 5 minutes after you add all the pieces.

If juice separation is not a concern, simply slice or quarter tomatoes into a large pot. Crush, heat, and simmer for 5 minutes before juicing.

Press heated juice through a sieve or food mill to remove skins and seeds. Heat juice again to boiling.

Add bottled lemon juice or citric acid to hot jars (page 9). Add salt, if desired (page 9). Fill hot jars with hot tomato juice, leaving ½-inch headspace. Remove air bubbles. Clean jar rims. Position lids and secure with bands.

**Pressure canning:** Process pints and quarts 15 minutes.

### TOMATO SAUCE

Prepare and press tomatoes as you would for making tomato juice (see recipe above). Heat in a large pot until sauce reaches desired consistency. Simmer until volume is reduced by about one-third for thin sauce or by one-half for thick sauce. Add bottled lemon juice or citric acid to hot jars (page 9). Add salt, if desired (page 9). Pour hot sauce into hot jars, leaving ½-inch headspace. Remove air bubbles. Clean jar rims. Position lids and secure with bands.

**Pressure canning:** Process pints and quarts 15 minutes.

### SALSA

Process salsa using the boiling water canning method only. Refer to page 24 for tested canning recipe.

## SPAGHETTI SAUCE WITHOUT MEAT

30 pounds tomatoes	¼ cup packed brown sugar
1 cup chopped onion	4 tablespoons dried parsley
1 cup chopped celery or green pepper	2 tablespoons dried oregano
1 pound fresh mushrooms, sliced (optional)	4½ teaspoons salt
5 cloves garlic, minced	2 teaspoons black pepper
¼ cup vegetable oil	

**NOTE:** Do not increase the proportion of onion, celery, green pepper, or mushrooms.

Wash tomatoes and dip in boiling water for 30 to 60 seconds or until skins split. Dip in cold water and slip off skins. Remove cores and quarter tomatoes. Boil 20 minutes, uncovered, in a large pot. Put through food mill or sieve. Sauté onion, celery or pepper, mushrooms (if desired), and garlic in vegetable oil until tender. Combine vegetables, tomatoes, sugar, parsley, oregano, salt, and pepper. Bring to a boil. Simmer, uncovered, stirring frequently until thick enough for serving. At this time the initial volume will have been reduced by nearly one-half. Fill hot jars with hot sauce, leaving 1-inch headspace. Remove air bubbles. Clean jar rims. Position lids and secure with bands.

*Yield: About 9 pints*

**Pressure canning:** Process pints 20 minutes and quarts 25 minutes.

## SPAGHETTI SAUCE WITH MEAT

30 pounds tomatoes	¼ cup packed brown sugar
2½ pounds ground beef or sausage	4 tablespoons dried parsley
1 cup chopped onion	2 tablespoons dried oregano
1 cup chopped celery or green pepper	4½ teaspoons salt
1 pound fresh mushrooms, sliced (optional)	2 teaspoons black pepper
5 cloves garlic, minced	

**NOTE:** Do not increase the proportion of onion, celery, green pepper, or mushrooms.

Wash tomatoes and dip in boiling water for 30 to 60 seconds or until skins split. Dip in cold water and slip off skins. Remove cores and quarter tomatoes. Boil 20 minutes, uncovered, in a large pot. Put through food mill or sieve. Brown beef or sausage. Add onion, celery or green pepper, mushrooms (if desired), and garlic. Cook until vegetables are tender. Combine with tomatoes in large pot. Add sugar, parsley, oregano, salt, and pepper. Bring to a boil. Simmer, uncovered, stirring frequently until thick enough for serving. At this time the initial volume will have been reduced by nearly one-half. Fill hot jars with hot sauce, leaving 1-inch headspace. Remove air bubbles. Clean jar rims. Position lids and secure with bands.

*Yield: About 9 pints*

**Pressure canning:** Process pints 60 minutes and quarts 70 minutes.

## PRESSURE CANNING *Vegetables*

**Pressure canning is the only safe method for canning vegetables.**

Young, tender, fresh, and slightly immature vegetables are better for canning than those which are overripe. As a rule, vegetables are best when canned immediately after picking, since flavor decreases upon standing and often unpleasant color changes take place. Avoid bruised vegetables because spoilage organisms grow more rapidly on bruised vegetables than on those that are unblemished.

Wash and prepare garden fresh vegetables as you would for cooking. When packing vegetables, always leave 1-inch headspace (or more if directed in recipe) in hot Mason jars.

To hot pack vegetables, precook in boiling water until heated through. Pack precooked vegetables into hot jars and cover with boiling water. Whenever possible, the precooking water should be used as liquid to cover the vegetables after packing into jars. However, there are a few vegetables, such as greens and asparagus, which make the cooking water bitter and undesirable to use.

To raw pack vegetables, simply place the prepared vegetables into hot jars and cover with boiling water.

### **Salt**

Vegetables may be processed with or without salt. Salt is used only for flavor, as it is not used in a large enough quantity to prevent spoilage. If salt is desired, use only canning or pickling salt. Table salt contains anti-caking agents that may cause cloudiness in the liquid inside the jars.

The recommended amount of salt is ½ teaspoon for each pint jar, 1 teaspoon for each quart jar.

**Tip:** Dry spices can safely be added to a tested canning recipe.

## CANNING RECIPES: VEGETABLES

### ASPARAGUS

Wash and drain asparagus. Remove tough ends and scales. Rinse. Leave asparagus whole or cut into pieces.

**Hot Pack:** Cover asparagus with boiling water and boil 2 to 3 minutes. Pack hot asparagus loosely in hot jars, leaving 1-inch headspace.

**Raw Pack:** Pack raw asparagus tightly in hot jars, leaving 1-inch headspace.

Add salt, if desired (page 11). Cover with boiling water, leaving 1-inch headspace. Remove air bubbles. Clean jar rims. Position lids and secure with bands.

**Pressure canning:** Process pints 30 minutes and quarts 40 minutes.

### BEANS OR PEAS—DRY

Sort out and discard any discolored beans/peas. Rehydrate beans/peas using **one** of the following methods:

- Place dry beans/peas in a large pot and cover with water. Soak 12 to 18 hours in a cool place. Then drain.

**OR**

- Cover beans/peas with boiling water in a large pot. Boil 2 minutes, remove from heat, and soak 1 hour. Then drain.

**Hot Pack:** Cover beans/peas soaked by either method with fresh water and boil 30 minutes. Add salt to hot jars, if desired (page 11). Fill jars with beans/peas and cooking water, leaving 1-inch headspace. Remove air bubbles. Clean jar rims. Position lids and secure with bands.

**Pressure canning:** Process pints 75 minutes and quarts 90 minutes.

### BEANS—FRESH LIMA, BUTTER, PINTO, OR SOY

Shell and wash young, tender beans thoroughly.

**Hot Pack:** Cover beans with boiling water and bring to a boil. Boil 3 minutes. Pack hot beans loosely in hot jars, leaving 1-inch headspace.

**Raw Pack:** Pack raw beans loosely in hot jars, leaving 1-inch headspace in pint jars. For quarts, leave 1½-inch headspace if beans are small and 1¼-inch headspace if beans are large.

Add salt, if desired (page 11). Cover with boiling water, leaving 1-inch headspace. Remove air bubbles. Clean jar rims. Position lids and secure with bands.

**Pressure canning:** Process pints 40 minutes and quarts 50 minutes.

### BEANS—GREEN, WAX, ITALIAN

Wash young, tender beans thoroughly. Remove stem and blossom ends or any strings. Leave whole or cut into 1-inch pieces.

**Hot Pack:** Cover beans with boiling water and boil 5 minutes. Pack hot beans loosely in hot jars, leaving 1-inch headspace.

**Raw Pack:** Pack raw beans tightly in hot jars, leaving 1-inch headspace.

Add salt, if desired (page 11). Cover with boiling water, leaving 1-inch headspace. Remove air bubbles. Clean jar rims. Position lids and secure with bands.

**Pressure canning:** Process pints 20 minutes and quarts 25 minutes.

### BEETS

Trim tops of young, tender beets, leaving 1 to 2 inches of stem and root to reduce bleeding of color. Wash thoroughly.

**Hot Pack:** Cover beets with boiling water and boil 15 to 25 minutes or until skins slip off easily. Remove skins, stems, and roots. Small beets may be left whole. Cut medium or large beets into ½-inch cubes or slices; halve or quarter very large slices. Pack hot beets in hot jars, leaving 1-inch headspace.

Add salt, if desired (page 11). Cover with boiling water, leaving 1-inch headspace. Remove air bubbles. Clean jar rims. Position lids and secure with bands.

**Pressure canning:** Process pints 30 minutes and quarts 35 minutes.

## CARROTS

Wash, peel, and rewash young, tender carrots. Carrots may be left whole, sliced, or diced.

**Hot Pack:** Cover carrots with boiling water, bring to a boil, and simmer 5 minutes. Pack hot carrots in hot jars, leaving 1-inch headspace.

**Raw Pack:** Pack raw carrots tightly in hot jars, leaving 1-inch headspace.

Add salt, if desired (page 11). Cover with boiling water, leaving 1-inch headspace. Remove air bubbles. Clean jar rims. Position lids and secure with bands.

**Pressure canning:** Process pints 25 minutes and quarts 30 minutes.

## CORN—WHOLE KERNEL

Husk and remove silk from young, tender, freshly-picked corn; wash ears. Blanch 3 minutes in boiling water. Cut corn from cob at about three-fourths the depth of the kernel. Do not scrape cob.

**Hot Pack:** For each quart of corn, add 1 cup boiling water. Bring to a boil and simmer 5 minutes. Pack hot corn loosely in hot jars, leaving 1-inch headspace.

**Raw Pack:** Pack raw corn loosely in hot jars, leaving 1-inch headspace.

Add salt, if desired (page 11). Cover with boiling water, leaving 1-inch headspace. Remove air bubbles. Clean jar rims. Position lids and secure with bands.

**Pressure canning:** Process pints 55 minutes and quarts 85 minutes.

## GREENS

Sort young, tender, freshly-picked greens; discard wilted or tough leaves, stems, and roots. Wash greens thoroughly.

**Hot Pack:** Blanch 1 pound of greens at a time, until well wilted (about 3 to 5 minutes). Pack hot greens loosely in hot jars, leaving 1-inch headspace.

Add salt, if desired (page 11). Cover with fresh boiling water, leaving 1-inch headspace. Remove air bubbles. Clean jar rims. Position lids and secure with bands.

**Pressure canning:** Process pints 70 minutes and quarts 90 minutes.

## MUSHROOMS—WHOLE OR SLICED

Trim stems and discolored parts of small to medium domestic mushrooms. Soak mushrooms in cold water for 10 minutes to remove soil. Wash in clean water. Leave small mushrooms whole; cut large ones.

**Hot Pack:** Cover mushrooms with water and boil 5 minutes. Pack hot mushrooms in hot jars, leaving 1-inch headspace. For better color, add  $\frac{1}{8}$  teaspoon of ascorbic acid per pint.

Add salt, if desired (page 11). Cover with boiling water, leaving 1-inch headspace. Remove air bubbles. Clean jar rims. Position lids and secure with bands.

**Pressure canning:** Process half-pints and pints 45 minutes.

**CAUTION!** In accordance with USDA guidelines, do not can wild mushrooms.

## OKRA

Wash and trim young, tender okra pods. Remove stem, without cutting into pods if okra is to be canned whole. If desired, slice okra into 1-inch pieces.

**Hot Pack:** Cover okra with hot water and boil 2 minutes. Pack hot okra in hot jars, leaving 1-inch headspace.

Add salt, if desired (page 11). Cover with boiling water, leaving 1-inch headspace. Remove air bubbles. Clean jar rims. Position lids and secure with bands.

**Pressure canning:** Process pints 25 minutes and quarts 40 minutes.

## PEAS—GREEN

Wash and shell young, tender freshly-picked green peas. Rinse.

**Hot Pack:** Cover peas with boiling water and bring to a boil. Boil 2 minutes. Pack hot peas loosely in hot jars, leaving 1-inch headspace. Do not shake or press down.

**Raw Pack:** Pack peas loosely in hot jars, leaving 1-inch headspace. Do not shake or press down.

Add salt, if desired (page 11). Cover with boiling water, leaving 1-inch headspace. Remove air bubbles. Clean jar rims. Position lids and secure with bands.

**Pressure canning:** Process pints and quarts 40 minutes.

## PEPPERS—HOT OR SWEET (including bell, chile, jalapeño, and pimiento)

**CAUTION!** Wear plastic or rubber gloves and do not touch your face while handling or cutting hot peppers. If you do not wear gloves, wash hands thoroughly with soap and water before touching your face or eyes.

**Preparation of chile peppers:** Cut two or four slits in each pepper and either blanch in boiling water or blister using one of the following methods:

- Oven or broiler method: Place chile peppers in a 400°F oven or broiler for 6 to 8 minutes until skins blister.
- Range-top method: Cover hot burner, either gas or electric, with heavy wire mesh. Place chiles on wire mesh for several minutes until skins blister.

Allow peppers to cool. Place in a pan and cover with a damp cloth. After several minutes, peel peppers. Remove stems and seeds.

**Preparation of other peppers:** Remove stems and seeds; blanch 3 minutes.

**Hot Pack:** Small peppers may be left whole. Large peppers may be quartered. Pack peppers loosely in hot jars, leaving 1-inch headspace.

Add salt, if desired (page 11). Cover with boiling water, leaving 1-inch headspace. Remove air bubbles. Clean jar rims. Position lids and secure with bands.

**Pressure canning:** Process pints 35 minutes.

## POTATOES—SWEET

Wash small to medium-sized sweet potatoes.

**Hot Pack:** Boil or steam sweet potatoes just until partially soft (15 to 20 minutes). Remove skins and cut into pieces of uniform size. Pack hot sweet potatoes in hot jars, leaving 1-inch headspace.

**CAUTION!** There are no tested recipes for mashed or pureed sweet potatoes. In accordance with USDA guidelines, do not mash or puree sweet potatoes as processing time may not be adequate.

Add salt, if desired (page 11). Cover with boiling water, leaving 1-inch headspace. Remove air bubbles. Clean jar rims. Position lids and secure with bands.

**Pressure canning:** Process pints 65 minutes and quarts 90 minutes.

## POTATOES—WHITE

Wash, peel, and rinse new potatoes 1 to 2 inches in diameter. If desired, cut into ½-inch cubes. Place in ascorbic acid solution (1 teaspoon ascorbic acid to 1 gallon water) to prevent darkening. Drain.

**Hot Pack:** Cover potatoes with hot water and bring to a boil. Boil whole potatoes for 10 minutes, cubes for 2 minutes. Pack hot potatoes in hot jars, leaving 1-inch headspace.

**CAUTION!** There are no tested recipes for mashed or pureed potatoes. Do not mash or puree potatoes as processing time may not be adequate.

Add salt, if desired (page 11). Cover with fresh boiling water, leaving 1-inch headspace. Remove air bubbles. Clean jar rims. Position lids and secure with bands.

**Pressure canning:** Process pints 35 minutes and quarts 40 minutes.

## PUMPKIN AND WINTER SQUASH\*

Wash and remove seeds from small-sized pumpkins or squash. Cut into 1-inch slices and peel. Cut flesh into 1-inch cubes.

**Hot Pack:** Boil cubes in water for 2 minutes. Pack hot pumpkin or squash cubes loosely in hot jars, leaving 1-inch headspace.

**CAUTION!** There are no tested recipes for mashed or pureed pumpkin or squash. In accordance with USDA guidelines, do not mash or puree pumpkin or squash as processing time may not be adequate.

Add salt, if desired (page 11). Cover with boiling water, leaving 1-inch headspace. Remove air bubbles. Clean jar rims. Position lids and secure with bands.

**Pressure canning:** Process pints 55 minutes and quarts 90 minutes.

*\*Types of winter squash that can safely be canned are acorn, buttercup, butternut, and hubbard.*

## PRESSURE CANNING *Meat, Game, Poultry, and Rabbit*

**Pressure canning is the only safe method for canning meat, game, poultry, and rabbit.**

Meat, game, poultry, and rabbit should be handled carefully to avoid contamination. Keep it as cool as possible during preparation for canning, handle rapidly, and process as soon as it is packed.

Use good quality product that has been trimmed of gristle, fat, and bruised spots. The hot pack method is recommended for the best liquid coverage and quality during storage.

To make broth, place bony pieces in a large pot and cover with cold water. Simmer until meat is tender. Discard fat. Add boiling broth to hot jars packed with precooked meat or poultry.

### Salt

Meat, game, poultry, and rabbit may be canned with or without salt. Salt is used only for flavor, as it is not used in a large enough quantity to prevent spoilage. If salt is desired, use only canning or pickling salt. Table salt contains anti-caking agents that may cause cloudiness in the liquid inside the jars.

The recommended amount of salt is ½ teaspoon for each pint jar, 1 teaspoon for each quart jar.

**Tip:** Dried herbs and spices can safely be added to a tested canning recipe.

## CANNING RECIPES: MEAT

### CUT-UP MEAT (strips, cubes, or chunks) Bear, Beef, Lamb, Pork, Veal, and Venison

Remove excess fat. Soak strong-flavored wild meats for 1 hour in brine water containing 1 tablespoon of salt per quart of water. Rinse. Remove large bones and cut into desired pieces.

**Hot Pack:** Precook meat until rare by roasting, stewing, or browning in a small amount of oil. Do not use flour. Pack hot meat loosely in hot jars, leaving 1-inch headspace. Add salt, if desired (see above). Cover meat with boiling broth, water, or tomato juice (especially with wild game), leaving 1-inch headspace. Remove air bubbles. Clean jar rims. Position lids and secure with bands.

**Raw Pack:** Add salt to hot jars, if desired (see above). Pack raw meat in hot jars, leaving 1-inch headspace. DO NOT ADD LIQUID. Clean jar rims. Position lids and secure with bands.

**Pressure canning:** Process pints 75 minutes and quarts 90 minutes.

### GROUND MEAT Bear, Beef, Lamb, Pork, Sausage, Veal, and Venison

Grind fresh meat in a food processor or meat grinder. For venison, add one part high quality pork fat to three or four parts venison before grinding. For sausage, use freshly made sausage seasoned with salt and cayenne pepper (do not use sage as it may cause a bitter flavor).

**Hot Pack:** Shape ground meat or sausage into patties or balls. Cook until lightly browned. Ground meat may also be cooked without shaping. Drain to remove excess fat. Pack hot meat loosely in hot jars, leaving 1-inch headspace. Add salt, if desired (see above). Cover meat with boiling water, broth, or tomato juice, leaving 1-inch headspace. Remove air bubbles. Clean jar rims. Position lids and secure with bands.

**Pressure canning:** Process pints 75 minutes and quarts 90 minutes.

## CANNING RECIPES: POULTRY AND RABBIT

### CHICKEN, DUCK, GOOSE, TURKEY

Cut poultry into serving size pieces. If desired, remove bone and skin.

**Hot Pack:** Precook poultry until almost done by baking, boiling, or steaming. Pack hot poultry in hot jars, leaving 1¼-inch headspace. Add salt, if desired (page 15). Cover poultry with hot broth, leaving 1¼-inch headspace. Remove air bubbles. Clean jar rims. Position lids and secure with bands.

**Raw Pack:** Add salt to hot jars, if desired (page 15). Pack raw poultry loosely in hot jars, leaving 1¼-inch headspace. DO NOT ADD LIQUID. Clean jar rims. Position lids and secure with bands.

	<u>With Bone</u>	<u>Without Bone</u>
<b>Pressure canning:</b> Process pints	65 minutes	75 minutes
Process quarts	75 minutes	90 minutes

### RABBIT

Soak dressed rabbits 1 hour in brine water containing 1 tablespoon of salt per quart of water. Rinse. Use preparation procedures and processing times for poultry, omitting salt.

### PRESSURE CANNING *Fish and Seafood*

**Pressure canning is the only safe method for canning fish and seafood.**

Only fresh fish should be canned. These should be bled and thoroughly cleaned of all viscera and membranes within 2 hours after they are caught. To prevent spoilage, keep fish and shellfish refrigerated or on ice to maintain a temperature of 40°F or below until ready to can.

## CANNING RECIPES: FISH AND SEAFOOD

### CLAMS—WHOLE OR MINCED

Keep clams on ice until ready to can. Scrub shells thoroughly and rinse.

**Hot Pack:** Steam 5 minutes and open. Remove clam meat. Collect and save clam juice. Wash clam meat in salted water using 1½ to 3 tablespoons of salt per gallon of water. Rinse.

Cover clam meat with boiling water containing 2 tablespoons of lemon juice or ½ teaspoon of citric acid per gallon. Boil 2 minutes and drain. To make minced clams, grind clams with a meat grinder or food processor. Heat reserved clam juice to boiling.

Pack clams loosely in hot jars, leaving 1-inch headspace. Add hot clam juice and, if needed, boiling water, leaving 1-inch headspace. Remove air bubbles. Clean jar rims. Position lids and secure with bands.

**Pressure canning:** Process half-pints 60 minutes and pints 70 minutes.

### FISH

#### Blue, Mackerel, Salmon, Steelhead, Trout, and other fatty fish except Tuna

Remove head, tail, fins, and scales. Wash fish in cold water.

**Raw Pack:** Split fish lengthwise and then cut into lengths that fit the jar size being used. Bones can be left in and skin left on, if desired. For halibut, remove the bones and skin.

Pack fish tightly in hot jars, skin side next to glass, leaving 1-inch headspace. Add ½ teaspoon canning salt to each half-pint jar, 1 teaspoon to each pint jar, if desired. DO NOT ADD LIQUID. Clean jar rims. Position lids and secure with bands.

**Pressure canning:** Process half-pints and pints 100 minutes.

**NOTE:** Glass-like crystals of magnesium ammonium phosphate sometimes form in canned salmon. There is no way for the home canner to prevent these crystals from forming, but they usually dissolve when heated and are safe to eat.

## TUNA

Remove viscera and clean fish thoroughly. Tuna may be canned either raw or precooked. Precooking removes most of the strong-flavored, natural oils.

**Hot Pack:** Place tuna belly-side down on a rack in the bottom of a large baking pan. Bake at 350°F for 1 hour. Refrigerate cooked fish overnight to firm the meat.

Remove skin. Cut meat away from bones; cut out and discard bone, fin bases, and dark flesh. Quarter the pieces; cut quarters crosswise into lengths suitable for the jar size being used.

Add ½ teaspoon canning salt to each half-pint jar, 1 teaspoon to each pint jar, if desired. Pack fish into hot jars, pressing down gently to make a solid pack, leaving 1-inch headspace. Add water or oil to jars, leaving 1-inch headspace. Remove air bubbles. Clean jar rims. Position lids and secure with bands.

**Raw Pack:** Remove skin. Separate the meat into quarters by cutting the meat away from bones. Cut out and discard bone, fin bases, and dark flesh. Cut quarters crosswise into lengths suitable for the jar size being used.

Add ½ teaspoon canning salt to each half-pint jar, 1 teaspoon to each pint jar, if desired. Pack fish into hot jars, pressing down gently to make a solid pack, leaving 1-inch headspace. **DO NOT ADD LIQUID.** Clean jar rims. Position lids and secure with bands.

**Pressure canning:** Process half-pints and pints 100 minutes.

## PRESSURE CANNING *Stock and Soup*

**Pressure canning is the only safe method for canning stock and soup.**

Dried herbs and spices can safely be added to a tested canning recipe.

## CANNING RECIPES: STOCK AND SOUP

### BEEF STOCK

Saw or crack fresh trimmed beef bones (with meat removed) to enhance extraction of flavor. Rinse bones.

**Hot Pack:** Place bones in a large pot and cover with water. Cover pot and simmer 3 to 4 hours. Remove bones. Cool broth; skim off and discard fat. Remove any tiny amount of meat tidbits from bones and add to broth, if desired. Reheat broth to boiling. Fill hot jars with hot broth, leaving 1-inch headspace. Remove air bubbles. Clean jar rims. Position lids and secure with bands.

**Pressure canning:** Process pints 20 minutes and quarts 25 minutes.

### CHICKEN AND TURKEY STOCK

**Hot Pack:** Place large carcass bones (with meat removed) in a large pot. Add enough water to cover bones. Cover pot and simmer 30 to 45 minutes or until meat can be easily removed from bones. Remove bones. Cool broth; skim off and discard fat. Remove any tiny amount of meat tidbits from bones and add to broth, if desired. Reheat broth to boiling. Fill hot jars with hot broth, leaving 1-inch headspace. Remove air bubbles. Clean jar rims. Position lids and secure with bands.

**Pressure canning:** Process pints 20 minutes and quarts 25 minutes.

## SOUPS

### **Vegetable, Dried Bean or Pea, Meat, Poultry, or Seafood\***

Choose your favorite vegetables, dried beans or peas, meat, poultry, or seafood ingredients for soup as long as those ingredients have their own individual canning recommendations. Do not use ingredients for which there are no canning recommendations.

**CAUTION!** In accordance with USDA guidelines, do not add noodles or other pasta, rice, cured or brined meat, flour, cream, milk, or other thickening agents, to home canned soups as processing time may not be adequate.

**Hot Pack:** Prepare vegetables, meat, poultry, and seafood\* as described in the hot pack directions for the individual ingredients. **If dried beans or peas are used, they must be fully rehydrated before adding to other ingredients** (see page 12). Combine solid ingredients with meat broth, tomatoes, or water to cover. Boil 5 minutes. Salt to taste, if desired. Fill jars halfway with solid ingredients and then add soup liquid, leaving 1-inch headspace. Remove air bubbles. Clean jar rims. Position lids and secure with bands.

**Pressure canning:** Process pints 60 minutes and quarts 75 minutes.

**\*If soup contains seafood, process pints and quarts 100 minutes.**

# BOILING WATER CANNING

## I. GETTING READY

1. Complete “Preparation Steps Before Canning” on pages 6 and 7. Select the boiling water canning recipe (see pages 21–26) and gather the needed supplies.
2. Begin preparing the food that will be used for filling the jars in step 13.

**NOTE:** Any food that is described in a recipe as “Hot Pack” should be freshly prepared or, if made in advance, it should be reheated as instructed in the canning recipe.

3. Place the removable pot in the canner body. Put the canning rack in the pot, feet side down.

**NOTE:** Jars will be placed on the rack in step 8. If set directly on the bottom of the pot, jars may break.

4. Pour 3 quarts of hot tap water into the pot, up to the fill line (Fig. A, page 3).

**Tip:** To help prevent mineral deposits on the canning rack and jars, add 1 teaspoon cream of tartar or 2 tablespoons white vinegar to the water in the pot.

5. Attach the power cord to the canner body, making sure to fully insert it in the receptacle. Then plug into a 120VAC wall outlet. The default icon **PRESSURE CAN** will flash in the display window.

6. **SLOWLY** rotate the control knob until **BOILING WATER CAN** flashes in the display (Fig. S).

Press the control knob to select the **BOILING WATER CAN** mode. The **BOILING WATER CAN** icon will remain illuminated for the duration of the canning process.

7. Rotate the knob to set the time for the specific boiling water canning recipe and jar size being used. The time adjusts in 5-minute increments up to 120 minutes. **IMPORTANT: Verify you have set the right program and time.** Make sure you have increased the processing time if you live at an altitude above 1,000 feet.

**NOTE:** If the **PRESSURE CAN** program is accidentally selected or the wrong time is entered, press and hold **⊗** for 3 seconds. Then repeat steps 6 and 7.

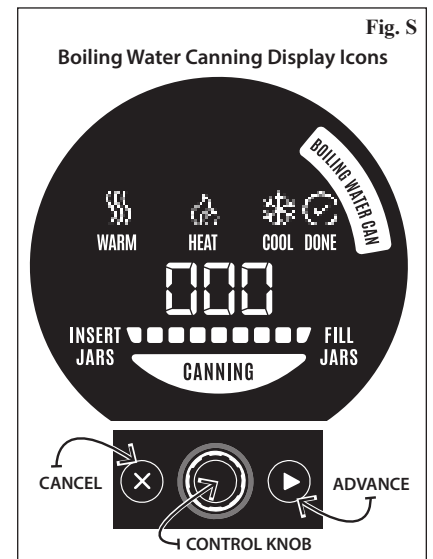

## II. JAR WARMING



8. Press **▶**. **INSERT JARS** will light up. Fill the canning jars half full with hot tap water and place them on the canning rack.
9. Position the sealing ring assembly on the removable pot rim (Fig. T).
10. **REMOVE THE REGULATOR** from the canner cover. Never use the regulator for boiling water canning.
11. Place the cover on the canner body, aligning the *INSTALL/REMOVE* vertical mark within the **┐** mark on the canner body (Fig. D, page 3). Rotate the cover clockwise until it stops. The canner cover is properly installed when the *LOCKED* vertical mark is within the **┐** mark on the canner body (Fig. U).

Keep the temperature sensor arm in the upright, unlocked position.



12. Press **▶**. **WARM** will light up and the progress bar will begin scrolling from left to right, indicating the unit is heating. Jar warming will take about 20 minutes.  
During this time, complete any necessary food preparation. Also, heat at least 3 quarts of water to boiling in a large kettle for use in step 14. More water will be needed if canner is not filled to jar capacity.

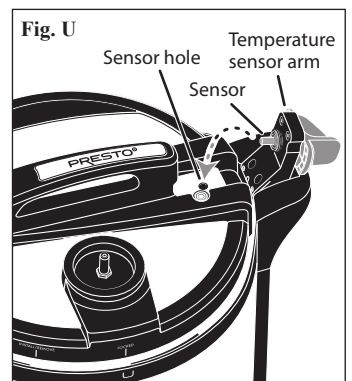
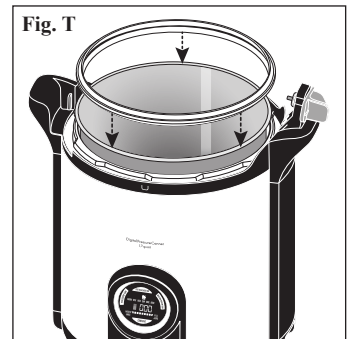

## III. FILL JARS



13. When the canner beeps twice and **FILL JARS** lights up, the jars are preheated and ready for filling. The canner will continue to keep the jars warm until you are ready to fill them. Unlock and remove the canner cover. Lift the cover toward you to keep any steam away from you.

Remove one jar at a time from the canner; discard the water from the jar. Immediately fill the jar with food and liquid, according to the specific tested recipe. Remove air bubbles by moving a clean, nonmetal spatula around the jar. Clean the jar rim with a damp cloth. Center a flat lid on the jar rim, making sure the sealing compound is touching the glass. Position a band over the lid and, using your fingertips, screw it onto the jar evenly and firmly (fingertip tight). Do not overtighten as air must release from the jars during processing and cooling. Place the jar on the canning rack promptly after filling.

Repeat the above procedure for each jar.

14. Pour additional boiling water (heated in step 12) around the jars in the removable pot so the water level is at least 1 inch above the jars.
15. Verify the sealing ring assembly is on the removable pot rim (Fig. T, page 18).
16. Place the cover back on the canner and lock it on. Lower the temperature sensor arm and insert the sensor into its hole in the cover (Fig. U, page 18). It may be necessary to rotate the cover slightly so the hole aligns with the sensor. Then, grasp the green latch and, using a slight downward pressure, turn the latch clockwise until it aligns with the handle (Fig. V).

**IMPORTANT: Verify that the regulator is not on the cover.**

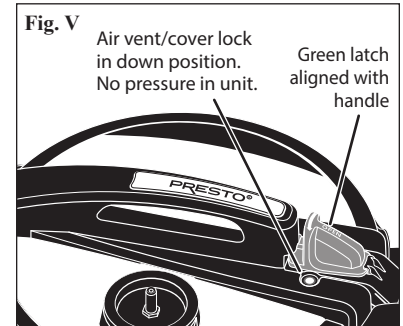

**IMPORTANT:** Never use the regulator when boiling water canning.

#### IV. CANNING



17. Press  **HEAT** will light up and the processing time programmed in step 7 will appear in the display. The progress bar will continue to scroll as the canner heats.

**NOTE:** In the event an incorrect processing time was entered, see *Frequently Asked Questions #1* on page 28.



18. Once the required canning temperature is reached, the unit will beep twice and **CANNING** will light up. The canner is now processing and the timer will start to count down. The progress bar will stop scrolling and begin to light up in segments, increasing in length as the processing time counts down (e.g., if 15 minutes of a 20 minute processing time have elapsed, 75% of the bars will be illuminated).

During canning there will be a noticeable amount of air/steam venting from the vent pipe and air vent/cover lock. You will also hear boiling.

#### V. COOLING



19. When the processing time expires, the canner will beep 4 times and **COOL** will light up. **5** will appear in the display. At this time, grasp the green latch, unlock it, and lift the sensor arm. Then carefully unlock and remove the canner cover for the cooling period.

**CAUTION!** To prevent burns, avoid contact with steam from the vent pipe and air vent/cover lock. When removing the canner cover, carefully lift it toward you to avoid steam and bubbling water.

The timer will count down during the cooling period. During the countdown, the progress bar will scroll from right to left to indicate the unit is cooling.

#### VI. DONE



20. When the time expires, the unit will beep 10 times and **DONE** will light up. Press and hold  for 3 seconds.
21. Using a jar lifter, remove jars by lifting them straight up. Be careful not to tilt the jars, which causes liquid to siphon out. Food particles may also get between the jar rim and the lid and prevent the jar from sealing. Place jars upright on a board or dry towel, away from drafts. Do not retighten bands. Allow jars to cool naturally. Check seals no earlier than 12 hours, but no later than 24 hours. See page 6 for “After Processing” information.
22. **When processing consecutive batches:** Before warming the next batch of jars, allow the water in the canner to cool or replace it with 3 quarts of fresh hot tap water. **NOTICE:** Placing jars immediately in the water from the previous batch can result in thermal shock to the glass jars that may in turn cause cracks and breakage.  
If reusing the water, it should not be above the 3-quart fill line (Fig. A, page 3). Remove excess water to a large kettle. Bring to a boil and use this water to cover the filled jars.
23. To can additional jars, repeat steps 6 to 22.
24. When canning is complete, unplug the cord from the wall outlet and then from the canner base. Allow canner to cool completely, empty water from removable pot, and clean according to the instructions on page 30.

## BOILING WATER CANNING

### Altitude Adjustments

When using the canner for boiling water canning at altitudes of 1,000 feet or below, process according to the specific recipe. When canning at higher altitudes, process according to the following chart.

ALTITUDE CHART BOILING WATER CANNING	
Altitude	Increase Recipe Processing Time
1,001–3,000 ft.	+5 minutes
3,001–6,000 ft.	+10 minutes
6,001–8,000 ft.	+15 minutes

### BOILING WATER CANNING *Fruits*

Select firm fruit that is fully ripened but not soft. Do not can overripe foods.

#### Maintaining Color

Some fruits (apples, apricots, nectarines, peaches, and pears) tend to darken while they are being prepared. To prevent darkening, place fruit in a solution of 3 grams (3,000 milligrams) ascorbic acid to 1 gallon of cold water. Ascorbic acid is available in different forms:

**Pure Powdered Form:** Use 1 teaspoon of pure powder, which weighs about 3 grams, per gallon of water.

**Vitamin C Tablets:** Buy 500 milligram tablets. Crush and dissolve 6 tablets per gallon of water.

**Commercially Prepared Mixes of Ascorbic and Citric Acid:** Available under different brand names. Use according to manufacturer's directions found on the package.

#### Canning Liquids

Although fruit has better color, shape, and flavor when it is canned with syrup, it may be canned in juices (such as apple, white grape, or pineapple) or water.

White sugar is preferable to brown sugar for canning. Light corn syrup or honey may be used to replace up to one-half the sugar. If you wish to use sugar substitutes, follow package instructions.

The amount of sugar desirable to use in preparing syrups will depend upon the tartness of the fruit and on personal preference. It should be remembered that fruit, when heated, releases some of its juices which will dilute the syrup in proportion to the juiciness of the fruit.

Use the syrup chart as a guideline for preparing syrup needed for your canning recipe. Syrup recipe may be doubled or tripled depending on the packing method and amount of fruit being canned at one time.

SYRUPS FOR CANNING FRUITS			
Combine sugar and water in a large pot. Bring to a boil and keep syrup hot while preparing fruit. Use as directed in recipe.			
Syrup	Sugar	Water	Yield
Very Light	½ cup	4 cups	4½ cups
Light	1 cup	4 cups	4¾ cups
Medium	1¾ cups	4 cups	5 cups
Heavy	2¾ cups	4 cups	5½ cups

## CANNING RECIPES: FRUITS

### APPLES

Wash, peel, and core apples. Cut into ½-inch slices. Place apples in an ascorbic acid solution (page 20) to prevent darkening during preparation. Drain well.

**Hot Pack:** Add apples and syrup (page 20), juice, or water to a large pot and bring to a boil. Boil for 5 minutes, stirring occasionally to prevent scorching. Pack hot apples in hot jars, leaving ½-inch headspace. Cover apples with hot syrup, juice, or water, leaving ½-inch headspace. Remove air bubbles. Clean jar rims. Position lids and secure with bands.

**Boiling water canning:** Process pints and quarts 20 minutes. For processing above 1,000 feet altitude, see page 20 for recommended increase in time.

### APPLESAUCE

Wash, peel, core, and slice apples. If desired, place apple slices into ascorbic acid solution (page 20) to prevent darkening. Drain well. Place slices in a large pot. Add ½ cup water. Heat quickly until apples are tender, stirring occasionally to prevent scorching. Press through food mill or sieve. (If chunk style sauce is preferred, omit this step.) If desired, sweeten to taste. Reheat sauce to boiling. Pack into hot jars, leaving ½-inch headspace. Remove air bubbles. Clean jar rims. Position lids and secure with bands.

**Boiling water canning:** Process pints 15 minutes and quarts 20 minutes. For processing above 1,000 feet altitude, see page 20 for recommended increase in time.

### APRICOTS

Wash well-ripened, firm apricots. If peeled apricots are desired, dip 1 minute in boiling water, then in cold water and peel. Cut apricots in halves and remove pits. Place apricots in an ascorbic acid solution (page 20) to prevent darkening during preparation. Drain well.

**Hot Pack:** Add apricots and syrup (page 20), juice, or water to a large pot and bring to a boil. Pack hot apricots, cut side down, in hot jars, leaving ½-inch headspace. Cover with hot syrup, juice, or water, leaving ½-inch headspace. Remove air bubbles. Clean jar rims. Position lids and secure with bands.

**Boiling water canning:** Process pints 20 minutes and quarts 25 minutes. For processing above 1,000 feet altitude, see page 20 for recommended increase in time.

**Raw Pack:** Pack raw apricots, cut side down, in hot jars, leaving ½-inch headspace. Cover with hot syrup, juice, or water, leaving ½-inch headspace. Remove air bubbles. Clean jar rims. Position lids and secure with bands.

**Boiling water canning:** Process pints 25 minutes and quarts 30 minutes. For processing above 1,000 feet altitude, see page 20 for recommended increase in time.

### BERRIES

#### Except strawberries and elderberries

Choose ripe, sweet berries with uniform color. Wash 1 to 2 quarts of berries at a time. Drain, cap, and stem if necessary.

**Hot Pack:** Use this method for firmer berries such as blueberries, currants, gooseberries, and huckleberries. Heat berries in a large pot with boiling water for 30 seconds and drain. Add ½ cup hot syrup (page 20), juice, or water to hot jars. Pack hot berries into jars, leaving ½-inch headspace. Cover with hot syrup, juice, or water, leaving ½-inch headspace. Remove air bubbles. Clean jar rims. Position lids and secure with bands.

**Boiling water canning:** Process pints and quarts 15 minutes. For processing above 1,000 feet altitude, see page 20 for recommended increase in time.

**Raw Pack:** Use this method for softer berries such as raspberries and blackberries. Add ½ cup hot syrup (page 20), juice, or water to hot jars. Pack raw berries into jars, leaving ½-inch headspace. Gently shake jars while filling to pack firmly without crushing berries. Cover with hot syrup, juice, or water, leaving ½-inch headspace. Remove air bubbles. Clean jar rims. Position lids and secure with bands.

**Boiling water canning:** Process pints 15 minutes and quarts 20 minutes. For processing above 1,000 feet altitude, see page 20 for recommended increase in time.

## CHERRIES

Stem and wash cherries. Remove pits, if desired. If pitted, place cherries in an ascorbic acid solution (page 20) to prevent darkening of the stem end. If canning whole cherries, prick each cherry with a clean needle to prevent splitting.

**Hot Pack:** Heat cherries in a large pot with ½ cup hot syrup (page 20), juice, or water per quart of cherries. Cover pot and bring to a boil. Pack hot cherries and cooking liquid in hot jars, leaving ½-inch headspace. Remove air bubbles. Clean jar rims. Position lids and secure with bands.

**Boiling water canning:** Process pints 15 minutes and quarts 20 minutes. For processing above 1,000 feet altitude, see page 20 for recommended increase in time.

## NECTARINES AND PEACHES–YELLOW

Wash fully-ripened but not soft yellow nectarines or peaches. Do not process white flesh nectarines or peaches as there are no tested recipes.

Skin can be left on nectarines. For peaches, loosen skin by dipping them 1 minute in boiling water, then in cold water. Peel. Cut fruit in halves and remove pits. Slice if desired. Place fruit in an ascorbic acid solution (page 20) to prevent darkening during preparation. Drain well.

**Hot Pack:** Add fruit and syrup (page 20), juice, or water to a large pot and bring to a boil. Pack hot fruit, cut side down, in hot jars, leaving ½-inch headspace. Cover with hot syrup, juice, or water, leaving ½-inch headspace. Remove air bubbles. Clean jar rims. Position lids and secure with bands.

**Boiling water canning:** Process pints 20 minutes and quarts 25 minutes. For processing above 1,000 feet altitude, see page 20 for recommended increase in time.

**Raw Pack:** Pack raw fruit, cut side down, in hot jars, leaving ½-inch headspace. Cover with hot syrup, juice, or water, leaving ½-inch headspace. Remove air bubbles. Clean jar rims. Position lids and secure with bands.

**Boiling water canning:** Process pints 25 minutes and quarts 30 minutes. For processing above 1,000 feet altitude, see page 20 for recommended increase in time.

## PEARS

Wash pears. Peel, cut in halves lengthwise, and core. Place pears in an ascorbic acid solution (page 20) to prevent darkening during preparation. Drain well.

**Hot Pack:** Add pears and syrup (page 20), juice, or water to a large pot and bring to a boil. Boil 5 minutes. Pack hot pears in hot jars, leaving ½-inch headspace. Cover with hot syrup, juice, or water, leaving ½-inch headspace. Remove air bubbles. Clean jar rims. Position lids and secure with bands.

**Boiling water canning:** Process pints 20 minutes and quarts 25 minutes. For processing above 1,000 feet altitude, see page 20 for recommended increase in time.

## PLUMS

Stem and wash firm, ripe plums. If plums are to be canned whole, prick each side with a fork. Freestone varieties may be cut in halves and pitted.

**Hot Pack:** Add plums and syrup (page 20), juice, or water to a large pot and bring to a boil. Boil 2 minutes. Cover pot and let stand 20 to 30 minutes. Pack hot plums in hot jars, leaving ½-inch headspace. Cover with hot syrup, juice, or water, leaving ½-inch headspace. Remove air bubbles. Clean jar rims. Position lids and secure with bands.

**Raw Pack:** Pack raw plums firmly in hot jars, leaving ½-inch headspace. Cover with hot syrup (page 20), juice, or water, leaving ½-inch headspace. Remove air bubbles. Clean jar rims. Position lids and secure with bands.

**Boiling water canning:** Process pints 20 minutes and quarts 25 minutes. For processing above 1,000 feet altitude, see page 20 for recommended increase in time.

## RHUBARB

Trim off leaves. Wash stalks and cut into ½-inch to 1-inch pieces.

**Hot Pack:** Add rhubarb and ½ cup sugar per quart of rhubarb to a large pot. Let stand until juice appears. Heat rhubarb slowly to boiling. Pack hot rhubarb in hot jars, leaving ½-inch headspace. Remove air bubbles. Clean jar rims. Position lids and secure with bands.

**Boiling water canning:** Process pints and quarts 15 minutes. For processing above 1,000 feet altitude, see page 20 for recommended increase in time.

## BOILING WATER CANNING *Tomatoes and Tomato Products*

Tomatoes and tomato products may be safely processed using the boiling water canning method or the pressure canning method. However, for some tomato products, the pressure canning method may result in a more nutritious canned product. (For pressure canning instructions, see page 9).

### Acidifying Tomatoes and Tomato Products

Tomatoes have a pH close to 4.6, which means it is necessary to take precautions to can them safely. First, carefully choose the tomatoes for canning. Use only tomatoes that are disease-free, preferably vine-ripened, and firm.

Second, an acid must be added to tomatoes whether they are processed using the boiling water canning method or pressure canning method. To ensure the safety of whole, crushed, or juiced tomatoes, add 1 tablespoon bottled lemon juice (not natural juice) or ¼ teaspoon citric acid per pint jar. For quarts, add 2 tablespoons bottled lemon juice or ½ teaspoon citric acid.

### Salt

Tomatoes and tomato products may be canned with or without salt. Salt is used only for flavor, as it is not used in a large enough quantity to prevent spoilage. If salt is desired, use only canning or pickling salt. Table salt contains anti-caking agents that may cause cloudiness in the liquid inside the jars.

The recommended amount of salt is ½ teaspoon for each pint jar and 1 teaspoon for each quart jar.

**Tip:** Dried herbs and spices can safely be added to a tested canning recipe.

Salt is optional when canning most foods. ACIDIFYING TOMATOES IS REQUIRED. Tomatoes have a pH close to 4.6, which means an acid must be added to obtain a safe food product.			
Most Foods <i>(add canning salt, if desired)</i>		Tomatoes <i>(must choose one)</i>	
ADD TO JAR	Canning Salt	Bottled Lemon Juice <i>(not natural juice)</i>	OR Citric Acid
PINT	½ teaspoon	1 tablespoon	¼ teaspoon
QUART	1 teaspoon	2 tablespoons	½ teaspoon

## CANNING RECIPES: TOMATOES AND TOMATO PRODUCTS

### TOMATOES—WHOLE OR HALVED (packed in water)

Wash smooth, firm, ripe tomatoes. Loosen skins by dipping tomatoes 1 minute in boiling water, then in cold water. Peel and remove core. Leave whole or halve, or if using large tomatoes, quarter.

**Hot Pack:** Place prepared tomatoes in a large pot and add just enough water to cover. Bring to a boil and boil gently for 5 minutes. Add bottled lemon juice or citric acid to hot jars (see above). Add salt, if desired (see above). Pack hot tomatoes in hot jars, leaving ½-inch headspace. Fill jars with hot cooking liquid, leaving ½-inch headspace. Remove air bubbles. Clean jar rims. Position lids and secure with bands.

**Raw Pack:** Add bottled lemon juice or citric acid to hot jars (see above). Add salt, if desired (see above). Pack prepared tomatoes in hot jars, leaving ½-inch headspace. Fill hot jars with boiling water, leaving ½-inch headspace. Remove air bubbles. Clean jar rims. Position lids and secure with bands.

**Boiling water canning:** Process pints 40 minutes and quarts 45 minutes. For processing above 1,000 feet altitude, see page 20 for recommended increase in time.

### TOMATOES—WHOLE OR HALVED (packed raw without added liquid)

Wash smooth, firm, ripe tomatoes. Loosen skins by dipping tomatoes 1 minute in boiling water, then in cold water. Peel and remove core. Leave whole or halve.

**NOTE:** Tomatoes that are raw packed will separate during processing into a liquid and solid, with the solids forming on top of the liquid. This is due to an enzyme that causes tomatoes to break apart when heated. Flavor and nutritional quality are not affected by this change.

Add bottled lemon juice or citric acid to hot jars (see above). Add salt, if desired (see above). Fill jars with raw tomatoes, pressing until spaces between them fill with juice. Leave ½-inch headspace. Remove air bubbles. Clean jar rims. Position lids and secure with bands.

**Boiling water canning:** Process pints and quarts 85 minutes. For processing above 1,000 feet altitude, see page 20 for recommended increase in time.

## TOMATO JUICE

Wash ripe, juicy tomatoes. Remove stem ends and trim off bruised or discolored portions. To prevent juice from separating, quickly cut about 1 pound of tomatoes into quarters and put directly into a large pot. Heat immediately to boiling while crushing. Continue to slowly add and crush freshly cut tomato quarters to the boiling mixture. Make sure the mixture boils constantly and vigorously while adding more tomatoes. Simmer 5 minutes after you add all the pieces.

If juice separation is not a concern, simply slice or quarter tomatoes into a large pot. Crush, heat, and simmer for 5 minutes before juicing.

Press heated juice through a sieve or food mill to remove skins and seeds. Heat juice again to boiling.

Add bottled lemon juice or citric acid to hot jars (page 23). Add salt, if desired (page 23). Fill hot jars with hot tomato juice, leaving ½-inch headspace. Remove air bubbles. Clean jar rims. Position lids and secure with bands.

**Boiling water canning:** Process pints 35 minutes and quarts 40 minutes. For processing above 1,000 feet altitude, see page 20 for recommended increase in time.

## TOMATO SAUCE

Prepare and press tomatoes as you would for making tomato juice (see recipe above). Heat in a large pot until sauce reaches desired consistency. Simmer until volume is reduced by about one-third for thin sauce or by one-half for thick sauce. Add bottled lemon juice or citric acid to hot jars (page 23). Add salt, if desired (page 23). Pour hot sauce into hot jars, leaving ½-inch headspace. Remove air bubbles. Clean jar rims. Position lids and secure with bands.

**Boiling water canning:** Process pints 35 minutes and quarts 40 minutes. For processing above 1,000 feet altitude, see page 20 for recommended increase in time.

## CANNING RECIPES: BOILING WATER METHOD

*The recipes on pages 24–26 are safely canned using the boiling water canning method. Do not use the pressure canning method for these recipes because the food quality will be unacceptable.*

**Important:** Jars used for the three preserve recipes (marked with a ❖) will need to be sterilized because the processing time is less than 10 minutes. To sterilize the jars, boil them for 10 minutes. If you live at an altitude of 1,000 feet or more, boil an additional minute for each 1,000-foot increase in altitude. If preferred, instead of sterilizing the jars, you can increase the processing time to 10 minutes. The additional processing time is not harmful to most gels.

## TOMATO SALSA

7 quarts peeled, cored, chopped paste tomatoes*	2 cups bottled lemon or lime juice
5 cups chopped onion	2 tablespoons salt
4 cups seeded, chopped long green chiles	1 tablespoon black pepper
½ cup seeded, finely chopped jalapeño peppers	<i>Optional ingredients:</i>
6 cloves garlic, finely chopped	3 tablespoons dried oregano
	2 tablespoons ground cumin
	2 tablespoons fresh cilantro

*\*This recipe works best with paste tomatoes, such as Roma. Slicing tomatoes, such as Beefsteak, require a much longer initial cooking time to achieve a desirable consistency.*

**CAUTION!** Wear plastic or rubber gloves and do not touch your face while handling or cutting hot peppers. If you do not wear gloves, wash hands thoroughly with soap and water before touching your face or eyes.

The jalapeño peppers do not need to be peeled. The skin of the long green chiles may be tough. If you choose to peel chiles, wash and dry them and then slit each pepper along the side to allow steam to escape. Blister skins by placing peppers in a hot oven (400°F) or under a broiler for 6 to 8 minutes until skins blister.

After blistering skins, place peppers in a pan and cover with a damp cloth. Cool several minutes; peel off skins. Discard seeds and chop.

Wash tomatoes and dip in boiling water for 30 to 60 seconds or until skins split. Dip in cold water, slip off skins, and remove cores. Combine all ingredients except oregano, cumin, and cilantro in a large pot and bring to a boil, stirring frequently, then reduce heat and simmer 10 minutes. Add oregano, cumin, and cilantro, if desired, and simmer for another 20 minutes, stirring occasionally.

Ladle hot salsa into hot jars, leaving ½-inch headspace. Remove air bubbles. Clean jar rims. Position lids and secure with bands.

**Boiling water canning:** Process pints 15 minutes. For processing above 1,000 feet altitude, see page 20 for recommended increase in time.

*Yield: About 16 to 18 pints*

## APPLE BUTTER ❖

*Recommended apples include Jonathan, Winesap, Stayman, Golden Delicious, and McIntosh.*

8 pounds apples	2½ cups packed brown sugar
2 cups apple cider	2 tablespoons ground cinnamon
2 cups vinegar	1 tablespoon ground cloves
2¼ cups sugar	

Wash apples. Remove stems, quarter, and core fruit. Cook apples slowly in apple cider and vinegar until soft. Press fruit through a colander, food mill, or strainer. Cook fruit pulp with sugar and spices, stirring frequently. To test for doneness, remove a spoonful and hold it away from steam for 2 minutes. It is done if the butter remains mounded on the spoon. Another way to determine when the butter is cooked adequately is to spoon a small quantity onto a plate. When a rim of liquid does not separate around the edge of the butter, it is ready for canning. Ladle hot butter into hot jars, leaving ¼-inch headspace. Remove air bubbles. Clean jar rims. Position lids and secure with bands.

**Boiling water canning:** Process half-pints and pints 5 minutes. For processing above 1,000 feet altitude, see page 20 for recommended increase in time.

*Yield: 8 to 9 pints*

*Apple Butter recipe adapted from the "Complete Guide to Home Canning," Agriculture Information Bulletin No. 539, USDA, revised 2009. National Center for Home Food Preservation.*

## GRAPE JELLY ❖

5 cups grape juice (about 3½ pounds grapes and about 1 cup water)	1 package powdered pectin 7 cups sugar
-------------------------------------------------------------------------	-------------------------------------------

**To prepare juice:** Sort, wash, and remove stems from fully ripe grapes. In a large pot, crush about 3½ pounds of grapes and add just enough water to cover grapes, about 1 cup. Cover and bring to a boil on high heat. Reduce heat and simmer for 10 minutes. Pour contents of pot into a damp jelly bag and suspend the bag to drain the juice into a large bowl. Allow juice to drain undisturbed overnight in a cool place. Strain through two thicknesses of damp cheesecloth to remove any crystals that have formed.

**To make jelly:** In a large pot combine juice and pectin; stir well. Place on high heat and, stirring constantly, bring quickly to a full rolling boil that cannot be stirred down. Add sugar, continue stirring, and heat again to a full rolling boil. Boil hard for 1 minute. Remove from heat; skim off foam quickly. Immediately ladle hot jelly into hot jars, leaving ¼-inch headspace. Remove air bubbles. Clean jar rims. Position lids and secure with bands.

**Boiling water canning:** Process half-pints and pints 5 minutes. For processing above 1,000 feet altitude, see page 20 for recommended increase in time.

*Yield: About 8 half-pints*

## RHUBARB STRAWBERRY JAM ❖

1 cup cooked red-stalked rhubarb (about 1 pound rhubarb and ¼ cup water)	6½ cups sugar 1 pouch liquid pectin
2½ cups crushed strawberries (about 1½ quarts)	

**To prepare fruit:** Wash rhubarb and slice thin or chop; do not peel. Add water, cover, and simmer until rhubarb is tender, about 1 minute. Sort and wash fully ripe strawberries; remove stems and caps. Crush berries.

**To make jam:** Measure prepared rhubarb and strawberries into a large pot. Add sugar and stir well. Place on high heat and, stirring constantly, bring quickly to a full rolling boil that cannot be stirred down. Boil hard for 1 minute, stirring constantly. Remove from heat and stir in pectin. Skim foam, if necessary. Immediately ladle hot jam into hot jars, leaving ¼-inch headspace. Remove air bubbles. Clean jar rims. Position lids and secure with bands.

**Boiling water canning:** Process half-pints and pints 5 minutes. For processing above 1,000 feet altitude, see page 20 for recommended increase in time.

*Yield: About 7 or 8 half-pints*

*Rhubarb Strawberry Jam and Grape Jelly adapted from "How to Make Jellies, Jams, and Preserves at Home," Home and Garden Bulletin No. 56. Extension Service, USDA. National Center for Home Food Preservation, June 2005.*

## QUICK FRESH-PACK DILL PICKLES

8 pounds 3- to 5-inch whole pickling cucumbers	2 tablespoons whole mixed pickling spice
2 gallons water	3 tablespoons whole mustard seed (1 teaspoon per pint jar)
1¼ cups canning or pickling salt (divided)	14 heads of fresh dill (1½ heads per pint jar) OR
1½ quarts vinegar (5% acidity)	4½ tablespoons dill seed (1½ teaspoons per pint jar)
¼ cup sugar	
2 quarts water	

Wash cucumbers. Cut ¼-inch slice off blossom end and discard, but leave ¼-inch of stem attached. Dissolve ¾ cup salt in 2 gallons water. Pour over cucumbers and let stand 12 hours. Drain. In a large pot combine vinegar, ½ cup salt, sugar, and 2 quarts water. Add mixed pickling spices tied in a clean, white cloth. Heat to boiling. Fill hot jars with cucumbers. Add 1 teaspoon mustard seed and 1½ heads fresh dill per pint. Cover with boiling pickling liquid, leaving ½-inch headspace. Remove air bubbles. Clean jar rims. Position lids and secure with bands.

**Boiling water canning:** Process pints 10 minutes and quarts 15 minutes. For processing above 1,000 feet altitude, see page 20 for recommended increase in time.

*Yield: About 7 to 9 pints*

**NOTE:** Many more tested canning recipes for jams and jellies, pickles and relishes, and salsa are available from the National Center for Home Food Preservation ([nchfp.uga.edu](http://nchfp.uga.edu)) or in these reliable sources:



“So Easy to Preserve”, Cooperative Extension The University of Georgia, bulletin 989; “Ball Blue Book Guide to Preserving”; “Bernardin Complete Book of Home Preserving”

## TROUBLESHOOTING



### Error Codes

The pressure canner is programmed to display error codes and to sound an alert in the event of an error in the processing procedure or a product malfunction. The alert will be a continuous tone for 5 seconds followed by repeating 1 second beeps. Be sure to note what error code is displayed before unplugging the canner.

See the following chart for explanation and remedies.

Code	Cause	Remedy
<b>E1, E2, E4, E5</b>	Canner has become damaged, been tampered with, or is defective.	Unplug canner and call Consumer Service Department (see page 31).
<b>E3</b> Can appear in any phase of Pressure and Boiling Water Canning	Canner is overheated as a result of insufficient or no water.	<ul style="list-style-type: none"> <li>• Unplug canner.</li> <li>• Remove regulator if still present on cover.</li> <li>• Unlock and remove cover.</li> <li>• Cool canner for 15 minutes.</li> <li>• Add water to the 3-quart fill line.</li> <li>• Lock on cover and plug in canner.</li> <li>• Select program and processing time and press .*</li> </ul> <p><b>NOTE:</b> If <b>E3</b> appears in Pressure Canning and the  icon is lit, it will be necessary to let pressure drop naturally until air vent/cover lock drops before unlocking and removing cover. Please refer to page 28 for additional information.</p>
<b>E10</b> Can appear only in JAR WARMING phase of Pressure and Boiling Water Canning	Canner has developed pressure during the JAR WARMING phase because the regulator was installed on the cover.	<ul style="list-style-type: none"> <li>• Unplug canner.</li> <li>• Wait for air vent/cover lock to drop.</li> <li>• <b>Remove regulator.</b></li> <li>• Unlock and remove cover.</li> <li>• Add water, as necessary.</li> <li>• Lock on cover and plug in canner.</li> <li>• Select program and processing time and press .*</li> </ul>

\*Press  again to display the  icon. At this point the regulator should NOT be on the cover.

Press and hold the  button for approximately 5 seconds until the display shows the  icon. This indicates the unit has bypassed the jar warming phase and is heating to reach the next phase.

Code	Cause	Remedy
<b>E20</b> Only in Pressure Canning	Canner has developed pressure during the VENTING phase because the regulator was installed on the cover.	<ul style="list-style-type: none"> <li>Follow remedy for E10, page 26.</li> </ul>
<b>E21</b> Only in Pressure Canning	The regulator was not installed after the completion of the VENTING phase.	<ul style="list-style-type: none"> <li>Unplug canner.</li> <li>Unlock and remove cover.</li> <li>Cool canner for 15 minutes.</li> <li>Add water, as necessary.</li> <li>Lock on cover and plug in canner.</li> <li>Select program and processing time and press .*</li> </ul>
<b>E30</b> Only in Boiling Water Canning	Canner has developed pressure because the regulator was installed on the cover.	<ul style="list-style-type: none"> <li>Unplug canner.</li> <li>Wait for air vent/cover lock to drop.</li> <li><b>Remove regulator.</b></li> <li>Unlock and remove cover.</li> <li>Check water level; add water if necessary.</li> <li>Lock on cover and plug in canner.</li> <li>Select program and processing time and press .*</li> </ul>
<b>E40</b> and <b>E50</b> Only in Pressure Canning	<p>Canner has sensed a release of pressure during CANNING phase as a result of:</p> <ul style="list-style-type: none"> <li>Removing the regulator.</li> <li>Sealing ring leaking because it is damaged or needs to be replaced.</li> </ul>	<ul style="list-style-type: none"> <li>Unplug canner.</li> <li>Allow canner to release pressure until air vent/cover lock drops.</li> <li>Remove regulator, if still present on cover.</li> <li>Unlock and remove cover.</li> </ul> <p><b>Canning process is not complete.</b> To be sure your food is safe, it must be reprocessed for the full amount of time (see page 28 for additional information).</p> <p><b>NOTE:</b> If release of pressure was due to sealing ring, replacement is necessary before using canner again. Please refer to page 31 for ordering replacement parts.</p>
<b>E41</b> Only in Pressure Canning	<p>Canner did not attain proper canning temperature within the required time frame as a result of:</p> <ul style="list-style-type: none"> <li>Sealing ring not properly installed or sealing ring assembly was not on removable pot.</li> <li>Regulator not on vent pipe.</li> <li>Air vent/cover lock did not lift.</li> </ul>	<ul style="list-style-type: none"> <li>Follow remedy for E40 and E50 above. In addition:</li> <li>Confirm sealing ring and air vent/cover lock gasket are in good condition and properly installed.</li> <li>Verify sealing ring assembly is on removable pot.</li> <li>After venting is complete, remember to place the regulator on the vent pipe and press  to advance to canning.</li> </ul>
<b>E60</b> Only in Pressure Canning	<p>Canner has sensed a premature release of pressure during the COOLING phase as a result of:</p> <ul style="list-style-type: none"> <li>Removing the regulator.</li> <li>Sealing ring leaking because it is damaged or needs to be replaced.</li> </ul>	<ul style="list-style-type: none"> <li>Follow remedy for E50 above.</li> </ul>

\*Press again to display the icon. At this point the regulator should NOT be on the cover.

Press and hold the button for approximately 5 seconds until the display shows the icon. This indicates the unit has bypassed the jar warming phase and is heating to reach the next phase.

## TROUBLESHOOTING

### Issues with Canned Food

- Jar breakage during processing is caused by: (1) packing jar too solidly or overfilling; (2) weakened, nicked, or chipped jars; (3) jars touching bottom of canner; (4) failure to tighten screw bands properly; (5) use of jars other than Mason jars.
- Liquid lost from jars during processing is caused by: (1) packing jar too solidly or overfilling; (2) failure to tighten screw bands properly.

If liquid is lost during processing, do not open jar to replace liquid. Loss of liquid will not cause spoilage, but food above the liquid will discolor. If at least half of the liquid is gone, place the jar in the refrigerator and use the food within 3 days.

- Flat sour, a type of food spoilage, is caused by canning overripe food, allowing precooked food to stand in the jar too long before processing, or keeping the jars in the canner too long after processing. It may be prevented by using fresh food; by properly processing, cooling, and storing food; and by removing jars from the canner promptly after processing. Flat sour shows no indication of spoilage until jar is opened. Flat sour is not a safety concern, but the taste of the food is compromised. It is advised that you discard the food.
- Food spoilage or jars not sealing is caused by: (1) failure to follow exact recipes and timetables; (2) failure to wipe sealing edge of jar clean before placing lid on jar; (3) foods, seeds, or grease lodged between lid and jar; (4) jars which are nicked, cracked, or have sharp sealing edges; (5) failure to tighten screw bands properly; (6) turning jars upside down while jars are cooling and sealing.
- If a jar does not seal by the time it is completely cool, and a minimum of 12 but no more than 24 hours have elapsed after canning, the food can be refrigerated and used within 3 days. Other options include freezing the food or reprocessing for the full amount of time per the canning recipe. If choosing to reprocess, remove the lids and reheat the food and/or liquid. Pack food into clean, heated jars. Remove air bubbles and clean jar rims. Position new lids on jars and secure with bands. **If more than 24 hours have elapsed since the canner registered DONE, and the seal is faulty, the food is no longer safe. Discard at once.**

Additionally, if an error code with an  or  appear during pressure canning, the food can be saved by refrigerating, freezing, or reprocessing.





- Mold can form only in the presence of air. Therefore, jars are not sealed if mold is present. Discard contents.
- The black deposit sometimes found on the underside of a lid is caused by tannins in the food or hydrogen sulfide which is liberated from the food by the heat of processing. This does not indicate spoilage.
- The loss of color from beets during canning is usually due to the variety of beets used. Two varieties that retain color well are Ruby Queen and Detroit Red. To reduce bleeding of color, precook beets with entire root and 1 to 2 inches of stem. Remove stem and root after precooking.

### Frequently Asked Questions





#### 1. I accidentally selected the wrong canning method and/or time and then started the program. What should I do?

Press and hold  (the cancel button) for 3 seconds. This will enable you to start over and select the correct program. The point at which this is discovered will determine how you should proceed. See below:

If discovered during the **INSERT JARS**, **FILL JARS**, or **VENT** phase of Pressure Canning, OR during the **CANNING** phase of the Boiling Water Canning function:

- Select the correct canning method and/or adjust the correct time. Press  once to activate the program.
- Press  again to display the  icon. At this point the regulator should NOT be on the cover.
- Press and hold the  button for approximately 5 seconds until the display shows the  icon. This indicates the unit has bypassed the jar warming phase and is heating to reach the next phase.

If discovered during the **CANNING** phase of the Pressure Canning function as indicated by the icon :

- Allow pressure to drop naturally until the air vent/cover lock drops. Once the air vent/cover lock has dropped, remove the regulator. Unlock and remove the cover.
- Check to see if jar lids have sealed. If lids have sealed, it will be necessary to remove the lids and replace with new ones.
- Select the correct canning method and/or adjust the correct time. Press  once to activate the program.
- Press  again to display the  icon. At this point the regulator should NOT be on the cover.
- Press and hold the  button for approximately 5 seconds until the display shows the  icon. This indicates the unit has bypassed the jar warming phase and is heating to reach the next phase. **NOTE:** If **PRESSURE CAN** is selected again, the canner will go through another venting period before the program moves to canning.

**2. Why is so much water required when I'm using the boiling water canning method?**

This canner follows USDA guidelines which require 1 to 2 inches of boiling water above the jars. That means you may process any approved boiling water canning recipe in this digital canner.

**3. When boiling water canning, once the jars are filled may I use hot tap water, instead of boiling water, to cover the filled jars?**

No. This canner follows USDA guidelines which require that boiling water be used to cover the jars.

**4. Water is collecting in the channel surrounding the removable pot and steam is leaking from around the canner cover. Why is this happening?**

The sealing ring was not properly installed or the sealing ring assembly was not positioned on the removable pot rim (see page 4). **NOTICE:** If the sealing ring is not in place during canning, the canner will leak, pressure will not build, and the canner may become damaged.

Leakage may also occur if the sealing ring needs to be replaced. The sealing ring is silicone and may stretch over time. If stretched, it may not fit properly on the metal frame. When this happens, replace the sealing ring before using the unit again.

**5. I'm only placing water and jars in the canner. Why do I need to check the vent pipe and filter before each use?**

Mistakes do happen in processing. Food does leak out of jars. Jars break. Some areas have water with heavy mineral deposits. Using best practices, the vent pipe and filter should be checked prior to each use and cleaned as needed.

**6. Can I use my favorite tested canning recipes for stovetop pressure canners in the electric canner?**

Yes, the Presto® Precise Digital Pressure Canner uses standard, research-tested processing guidelines for both pressure canning and boiling water canning from the USDA publication, "Complete Guide to Home Canning." These are the same recipes used with stovetop Presto® pressure canners.

**7. Is it safe to use canning recipes found on the web or passed down from family?**

Always use reliable sources that offer current, research-tested procedures, recipes, and timetables. Such information is available in this instruction manual or at [www.GoPresto.com](http://www.GoPresto.com). In addition, the National Center for Home Food Preservation ([nchfp.uga.edu](http://nchfp.uga.edu)) and your local Cooperative Extension Service are also reliable sources of home canning information and established processing procedures. Using only scientifically tested canning recipes is vital to a safe and successful home canning project. Canning information published before 2015 may be incorrect and could pose a serious health risk.

**8. Can I use jars that are smaller than what is listed in my canning recipe?**

If you are using a research-tested recipe, you may use glass home canning jars that are smaller than the jar size specified in the recipe. However, you must use the processing time listed for the smallest jar in the recipe. Never use a larger jar than what is listed.

**9. Can I can my leftovers?**

Canning leftovers is not safe and should not be done. Canning is a science and many factors are involved (type of food, acidity or pH of food, density of food, heat penetration). When you change a recipe or use untested recipes, you change the outcome and safety of the canned product. Use **only** tested canning recipes. Add any special ingredients to canned products when ready to use them.

**10. Is it okay to leave processed jars in the canner overnight or for an extended period of time after canning is complete?**

No. The jars should be removed within a couple of hours of canning. If processed jars are left in the canner overnight or for an extended period of time, this may result in flat-sour, a type of food spoilage.

## CLEANING

### After every use

1. After the canner has cooled completely, detach the sealing ring from the metal frame (Fig. E, page 3). Thoroughly dry the sealing ring and the inside of the canner cover. Reattach the sealing ring to the frame.

If the vent filter appears dirty or contains debris, remove it from the underside of the cover following the instructions on page 3. Wash it in warm, soapy water.

If necessary, wipe the outside of the canner cover with a damp cloth and then dry completely. **Do NOT immerse the canner cover in water or wash it or its parts in the dishwasher.**

2. To be sure the vent pipe is clear, hold the cover up to a light and look through the vent pipe. Clean it with a small brush or pipe cleaner if it is blocked or partially blocked. If necessary, clean the vent filter with a small brush to remove any food particles from the slots and holes. Rinse and dry all parts thoroughly and reassemble.
3. Wash the canning rack and removable pot in warm water and a mild detergent. Rinse and dry thoroughly. **Do NOT wash the removable pot in the dishwasher.**

**CAUTION!** To prevent electrical shock and damage to the canner, never pour water into the canner body or immerse it or the power cord in water. Always be sure the pot is completely dry before placing it back in the canner body.

### As Needed

1. Remove the air vent/cover lock for cleaning. Place your finger over the top of the air vent/cover lock on the cover (Fig. W) and remove the gasket at the end of the metal shaft from the underside of the cover (Fig. X). Push the air vent/cover lock through the top of the cover.

Wash it and the gasket in warm, soapy water. The metal shaft may be cleaned with a nylon mesh pad. Clean the cover hole with a small brush.

After cleaning, reinsert the metal shaft from the top side of the cover down through the cover hole. Place a finger over the top of the air vent/cover lock and push the gasket onto the end of the metal shaft, fitting it into the groove.

2. Gently clean the sensor, the temperature sensor arm, and the plastic rim of the canner body with a damp cloth. Avoid getting water inside the canner body.

Carefully remove the gasket on the sensor (Fig. Y) and wash it in warm, soapy water. Clean the sensor with a damp cloth and place the gasket back on the sensor.

3. Wipe the outside of the canner body with a damp cloth.

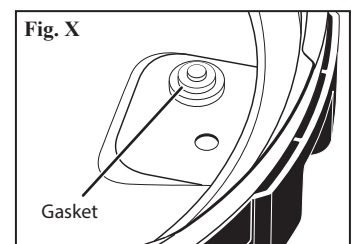
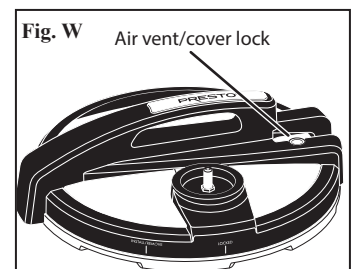

## CARE AND MAINTENANCE

- When not in use, store the electric canner in a dry place at temperatures above freezing. Exposure to temperatures below freezing may damage the canner. The canner should be completely dry before storing. To prevent unpleasant odors from lingering, store the canner with the cover inverted on the canner body.
- Do not use metal utensils as they may scratch the nonstick surface.
- Do not strike the rim of the pot with any utensil. This could damage the rim which may allow steam to escape and prevent the canner from sealing.
- Periodically check the air vent/cover lock gasket and sensor gasket. Replace these parts when they become hard, deformed, cracked, or torn.
- Also check the sealing ring occasionally. The sealing ring is silicone and may stretch over time. If stretched, it may not fit properly on the metal frame and should be replaced. If it is not replaced, you may notice steam escaping and/or receive an error code when processing.
- The air vent/cover lock gasket and the sensor gasket deteriorate over time (become hard, deformed, cracked, torn with normal use). If you begin to notice steam escaping or receive an error code, these parts may need to be replaced.
- Replacement of the sealing ring, air vent/cover lock gasket, and sensor gasket is considered routine maintenance and not covered under the warranty.
- Periodically check the vent pipe nut for looseness. If necessary, retighten with a ½" wrench.
- If for any reason the canner cannot be opened, contact the Consumer Service Department in Eau Claire, WI at 1-800-877-0441 for assistance.
- Any maintenance required for this product, other than normal household care and cleaning, should be performed by National Presto Industries, Inc. (see page 31).

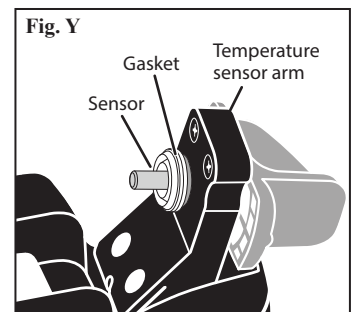

## RECIPE INDEX

### Pressure Canning Recipes

#### *Tomatoes and Tomato Products*

Tomatoes (packed in water) . . . . .	10
Tomatoes (no added liquid) . . . . .	10
Tomato Juice . . . . .	10
Tomato Sauce . . . . .	10
Spaghetti Sauce without Meat . . . . .	11
Spaghetti Sauce with Meat . . . . .	11

#### *Vegetables*

Asparagus . . . . .	12
Beans or Peas—Dry . . . . .	12
Beans—Fresh Lima, Butter, Pinto, or Soy . . . . .	12
Beans—Green, Wax, Italian . . . . .	12
Beets . . . . .	12
Carrots . . . . .	13
Corn—Whole Kernel . . . . .	13
Greens . . . . .	13
Mushrooms—Whole or Sliced . . . . .	13
Okra . . . . .	13
Peas—Green . . . . .	14
Peppers—Hot or Sweet . . . . .	14
Potatoes—Sweet . . . . .	14
Potatoes—White . . . . .	14
Pumpkin and Winter Squash . . . . .	15

#### *Meat, Game, Poultry, and Rabbit*

Cut-Up Meat . . . . .	15
Ground Meat . . . . .	15
Chicken, Duck, Goose, Turkey . . . . .	16
Rabbit . . . . .	16

#### *Fish and Seafood*

Clams—Whole or Minced . . . . .	16
Fish . . . . .	16
Tuna . . . . .	17

#### *Stock and Soup*

Beef Stock . . . . .	17
Chicken and Turkey Stock . . . . .	17
Soups . . . . .	17

### Boiling Water Canning Recipes

#### *Fruits*

Apples . . . . .	21
Applesauce . . . . .	21
Apricots . . . . .	21
Berries . . . . .	21
Cherries . . . . .	22
Nectarines and Peaches—Yellow . . . . .	22
Pears . . . . .	22
Plums . . . . .	22
Rhubarb . . . . .	22

#### *Tomatoes and Tomato Products*

Tomatoes (packed in water) . . . . .	23
Tomatoes (no added liquid) . . . . .	23
Tomato Juice . . . . .	24
Tomato Sauce . . . . .	24
Tomato Salsa . . . . .	24

#### *Jam, Jelly, Soft Spreads*

Apple Butter . . . . .	25
Grape Jelly . . . . .	25
Rhubarb Strawberry Jam . . . . .	25

#### *Pickles*

Quick Fresh-Pack Dill Pickles . . . . .	26
-----------------------------------------	----

## CONSUMER SERVICE INFORMATION

If you have any questions regarding the operation of your Presto® appliance, or need parts or repair for your appliance, contact us by any of these methods:

- Call 1-800-877-0441 weekdays 8 a.m. to 4 p.m. (Central Time)
- Email us through our website at [www.GoPresto.com/contact](http://www.GoPresto.com/contact)
- Chat at [GoPresto.com](http://GoPresto.com) weekdays 9 a.m. to 12 noon and 1 to 3 p.m. (Central Time)
- Write: National Presto Industries, Inc., Consumer Service Department  
3925 North Hastings Way, Eau Claire, WI 54703-3703

Inquiries will be answered promptly by email, telephone, or letter. When emailing or writing, please include a phone number and a time when you can be reached during weekdays if possible.

When contacting the Consumer Service Department or when ordering replacement parts, please indicate the model and series numbers for the pressure canner. The model number can be found on the back of the canner body. The series number is located on the black panel above the cord receptacle (Fig. Z).

Please record this information:

Model \_\_\_\_\_ Series \_\_\_\_\_ Date Purchased \_\_\_\_\_

The Presto Service Department is equipped to service this Presto® Digital Canner and supply genuine Presto® parts. Genuine Presto® replacement parts are manufactured to the same exacting quality standards as Presto® appliances and are engineered specifically to function properly with its appliances. Presto can only guarantee the quality and performance of genuine Presto® parts. “Look-alikes” might not be of the same quality or function in the same manner. To ensure that you are buying genuine Presto® replacement parts, look for the Presto® trademark.

National Presto Industries, Inc., Consumer Service Department  
3925 North Hastings Way, Eau Claire, WI 54703-3703

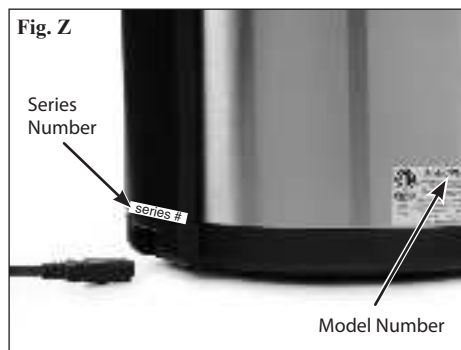

## Product Registration

**IMPORTANT:** Please go online and register this product within 10 days of purchase. Proper registration will serve as proof of purchase in the event your original receipt becomes misplaced or lost. Registration will not affect warranty coverage, but it may expedite the processing of warranty claims. The additional information requested will help us develop new products that best meet your needs and desires.

To register the product, visit [GoPresto.com/registration](http://GoPresto.com/registration) or simply scan this QR code. If you do not have computer access, contact the Consumer Service Department at 1-800-877-0441 for assistance with registration.



Created by Presto, the Official Presto Precise® Digital Canner Facebook Group offers a social networking environment to share your canning experiences, as well as the opportunity to learn accurate information about your digital canner and canning in general, straight from the company.

To join this group, visit: [www.facebook.com/groups/prestodigitalcanner](http://www.facebook.com/groups/prestodigitalcanner)

For more canning information and recipes, visit: [www.GoPresto.com/content/canning](http://www.GoPresto.com/content/canning)

### Presto® Limited Warranty

*(Applies only in the United States)*

This quality Presto® appliance is designed and built to provide many years of satisfactory performance under normal household use. Presto pledges to the original owner that should there be any defects in material or workmanship during the first year after delivery of the Presto® appliance, we will repair or replace it at our option. Our pledge does not apply to normal wear and tear including scratches, dulling of the polish, or staining; the repair or replacement of moving and/or perishable parts such as the sealing ring, regulator, air vent/cover lock gasket, or sensor gasket; or for any damage caused by shipping. **Outside the United States, this limited warranty does not apply.**

To obtain service under the warranty, please call our Consumer Service Department at 1-800-877-0441 or visit [www.GoPresto.com/contact](http://www.GoPresto.com/contact). If unable to resolve the problem, you will be instructed to send your Presto® appliance to the Presto Service Department for a quality inspection; shipping costs will be your responsibility. When returning an appliance, please include your name, address, phone number, and the date you purchased the appliance as well as a description of the problem you are encountering with the appliance.

Because we cannot control the quality of appliances sold by unauthorized sellers, this warranty applies only to appliances that were purchased from Presto® or a Presto authorized seller, unless otherwise prohibited by law. We reserve the right to reject warranty claims for appliances purchased from unauthorized sellers, including unauthorized internet sites. For additional information, visit [www.GoPresto.com/downloads/warranty](http://www.GoPresto.com/downloads/warranty) or simply scan this QR code.



We want you to obtain maximum enjoyment from using this Presto® appliance and ask that you read and follow the instructions enclosed. Failure to follow instructions, damage caused by improper replacement parts, abuse, misuse, disassembly, alterations, or neglect will void this pledge. This warranty gives you specific legal rights, and you may also have other rights which vary from state to state. This is Presto's personal pledge to you and is being made in place of all other express warranties.

National Presto Industries, Inc.  
Eau Claire, WI 54703-3703