



INSTALLATION GUIDE



ACURA TLX 2.0T (2021+)
FRONT MOUNT INTERCOOLER

PRL INSTALLATION OVERVIEW

PRODUCT: PRL-HA10-IC PRL MOTORSPORTS FRONT MOUNT INTERCOOLER

FITMENT: 2021+ Acura TLX 2.0T

INSTALLATION TIME: Approximately 3 hours

NOTE: THIS ITEM DOES NOT REQUIRE AN ECU RE-CALIBRATION.

Please check that all components that are listed in the parts list have been supplied to you, and are correct. If you require any assistance or are missing components please email: support@prlmotorsports.com. Please verify with a customer service representative before installation or returning the product.

PRODUCT DISCLAIMER:

United States 48 State Compliant:

California/New York Residents please see Prop 65.

This is a Race Only product that is to be used solely for competition, it cannot be used on vehicles that are operated on public streets, roads or highways. Its use is limited to closed-course and open-course racing that is formally sanctioned by a recognized racing organization. Any other use including recreational use could be in violation of local, state and federal laws.

PRL Motorsports is not responsible for any vehicle damage or personal injury that may occur due to an installation error, product misuse, or removal of PRL Motorsports products.

PRL Motorsports highly suggests that a trained professional conduct the installation on all products. PRL Motorsports is not responsible for damaged products due to incorrect installation.

REQUIRED TOOLS:

Ratchet

Extension (6 - 12" Length)

10mm Socket

14mm Socket

1/4" Hex Socket (Dependant on End Tank Hardware Connection)

Torque Wrench

Needle Nose Pliers

Phillips Head Screw Driver

Flat Head Screw Driver

Clip Removal Tool

Combination Square / Measuring Tape

Permanent Marker

Angle Grinder / Cutting Wheel (Bumper Beam Trimming is Required)

Drill

Eye Protection

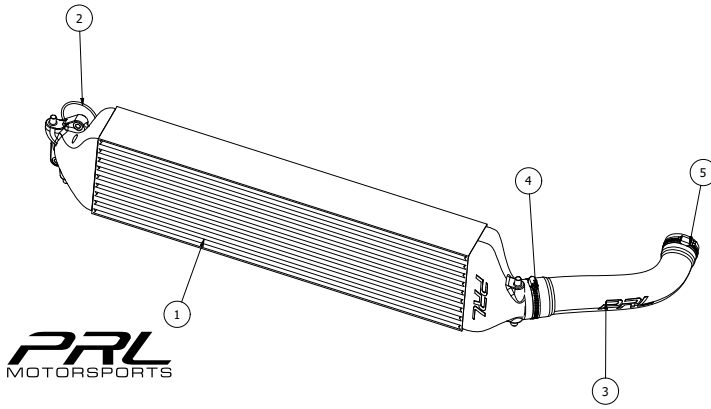

PRL
MOTORSPORTS

COMPONENT LIST

#	PART #	QTY	DESCRIPTION
1	PRL-HA10-IC	1	2021+ Acura TLX / 2019+ Acura RX Intercooler
2	MCM-9452K69	1	Hot Side End Tank O-Ring
3	PRL-ATLX2-20T-IC-OUT	1	2021+ Acura TLX Silicone Intercooler Hose
4	IFE-60-80-12	1	#44 Hose Clamp (Stainless)
5	IFE-50-70-12	1	#36 Hose Clamp (Stainless)
6	PRL-HCR-IC-STEN	1	Standard PRL Logo Stencil (Cardboard)

Before Beginning Your Installation:

1. Turn off the ignition. Loosen battery terminal and disconnect the negative battery terminal cable. Allow the vehicle to sit for a minimum of 5 minutes to drain any remaining charge from the charging system.

NOTE: Disconnection of the negative battery cable erases pre-programmed electronic memory. We recommend saving any memory settings before disconnecting the negative terminal. Some radios will require an anti-theft code to be entered after the negative battery cable is reconnected.

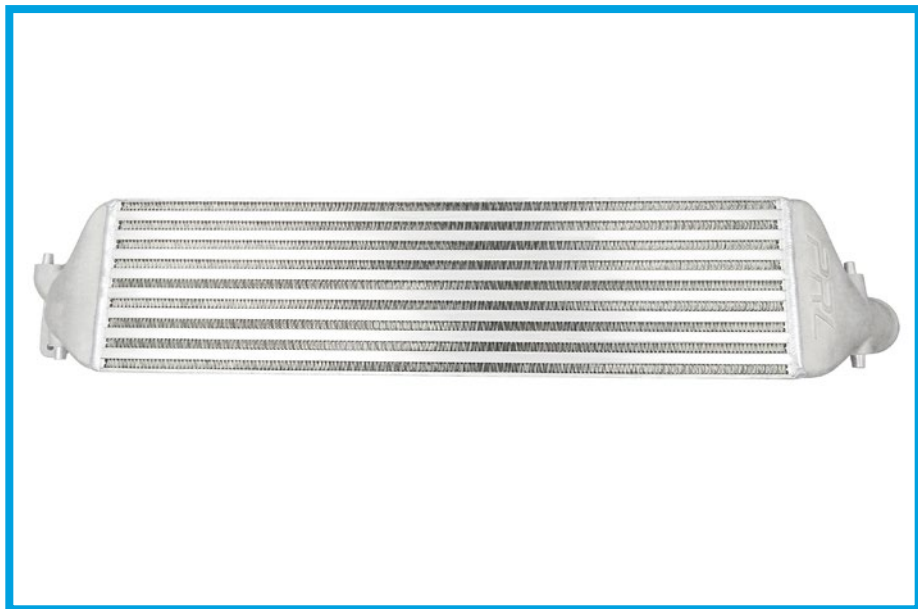

Preparing Your Front Mount Intercooler:

2. Set on even, clean surface to ensure to not damage the intercooler while removing the front bumper. Reference the parts list and ensure all components are enclosed. If something is missing, please contact PRL Customer Support.

3. The front bumper of the car will need to be removed to access the factory intercooler. If applying the stencil, do so now. Follow this video for bumper removal: <https://www.youtube.com/watch?v=5T7nLVFvexQ>

4. Rotate and ensure you have the PRL Front Mount Intercooler facing the correct orientation. The driver's side has the PRL logo engraved into the tank.

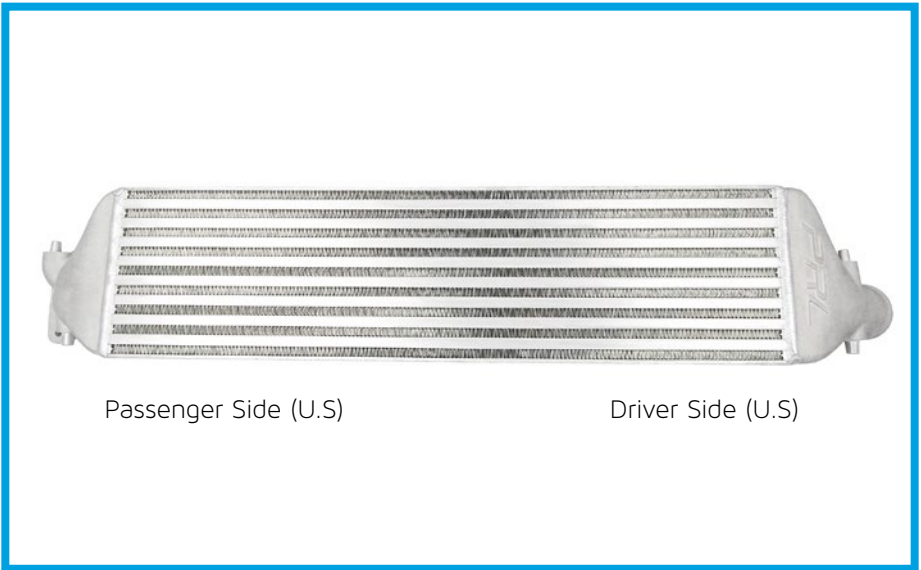

5. PLEASE NOTE: If you are applying the PRL Logo utilizing our stencil, do so when the PRL Front Mount Intercooler is NOT installed. This is to avoid overspray onto the paint and trim.



6. After removing the front bumper, you'll need to remove the factory brackets holding the factory intercooler from the car.



7. Remove the (2) factory 10mm bolts per side of the factory intercooler. Make sure to keep these bolts, as they will be reused with the PRL Intercooler.



8. Remove the (2) rubber grommets from the factory intercooler and place them on the PRL Intercooler. This will let the intercooler sit in the mounts.



9. Remove the vertical support bracket located behind the factory intercooler. Remove the (1) 10mm bolt and (1) 10mm nut. This bracket will be removed permanently, unless you would like to fabricate your own support bracket.



10. The bumper beam needs to be trimmed to provide clearance, as the PRL intercooler is far larger than factory. You will need to remove the (5) 14mm & (1) 10mm factory bolts, per side to remove the bumper beam.

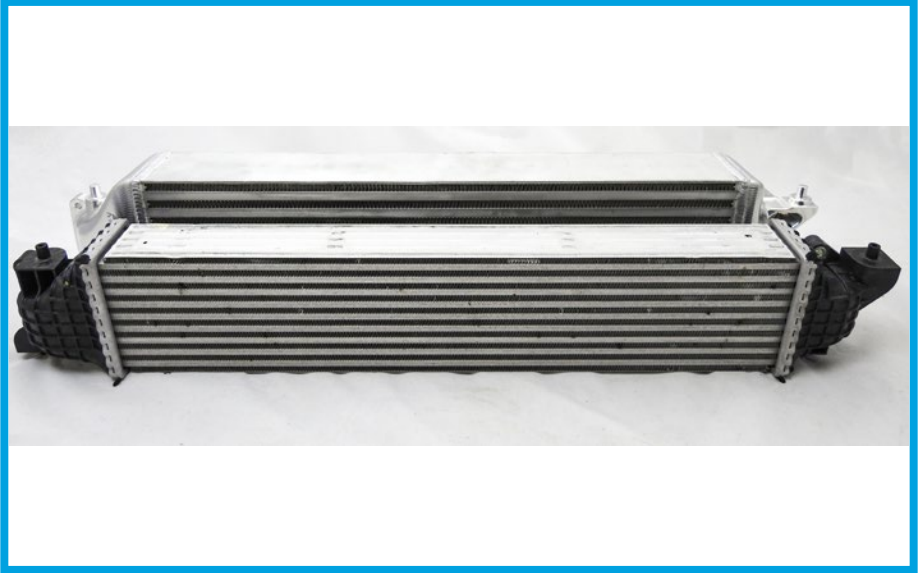

11. Seat the PRL Intercooler into the factory mount location, then with the help of a friend or two, line up the bumper beam to it's mounting location. Using a permanent marker, mark a line at each edge where the intercooler ends on the bumper beam. This line will indicate your end cuts on the bumper beam.



12. Using a combination square, measure 1-5/8" and mark a straight line and a dot at the end. This is where you will drill and make your vertical cut on each end.

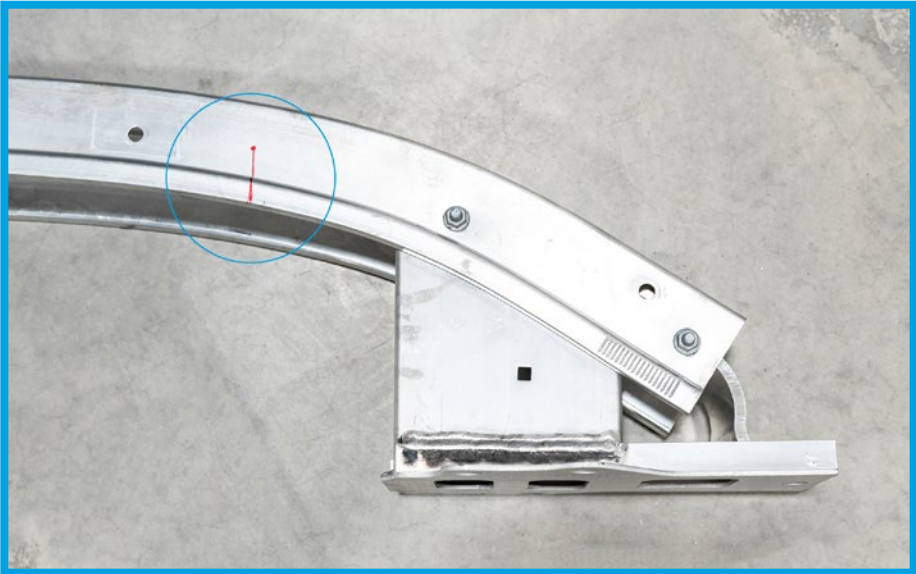
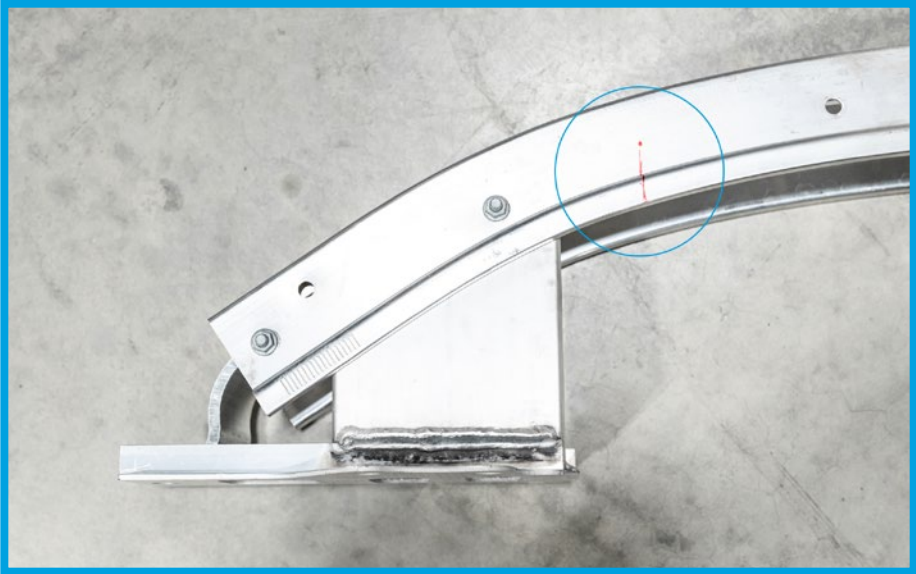

13. Using a cutting wheel or angle grinder, cut an arched line across the bumper beam, underneath the factory holes that are placed in the bumper beam. Do not cut fully through the holes or the factory plastics will not seat in the beam.

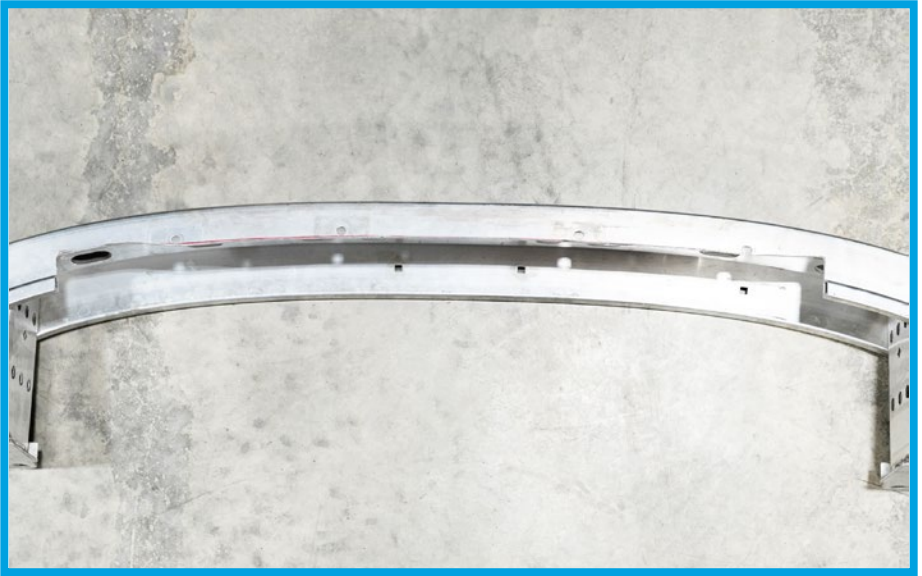

14. Place the PRL silicone hose on the driver's side, with the provided worm gear clamp. Affix the factory bracket on the top of the intercooler using the rubber grommet and the (1) 10mm bolt.



18. If you have not already done so, torque down the (2) factory 12mm bolts on passenger side of the end tank to the factory charge pipe.

**** RECOMMENDED TORQUE SPEC - 18 ft/lbs ****



19. Align the PRL silicone with the factory charge pipe and ensure it's seated. Tighten down the (2) provided worm gear clamps till they are secure.



20. Before you reinstall the now trimmed bumper beam, you will need to trim the plastic air guide to fit correctly. There should be an air gap all around the PRL Intercooler, the bumper beam should not make contact with it at all.



21. Once the bumper beam is re-installed, follow the bumper removal steps in reverse, making sure to re-install all harnesses.



Road Testing Your PRL Front Mount Intercooler

1. Start the vehicle with the transmission in neutral and the emergency brake engaged. Assess to make sure of any possible issue(s) and then make any subsequent adjustments as they are needed.
2. Test drive the vehicle to ensure everything is in working order.
3. If after the road testing, everything is good to go, enjoy your PRL Front Mount Intercooler! Thank you for being a part of the #PRLARMY.

If you have any questions/concerns please reach out to us at:
support@PRLMotorsports.com

Please provide a full description of your issue, ideally with any pertinent images or video clips that can help our team address the issue.

Please note: All support tickets are addressed during business hours and in order of received.

As stated at the beginning of this guide, the PRL Front Mount Intercooler has been specifically designed to be 100% compatible with the factory ECU calibration. No tuning is required to benefit from the advertised gains and performance. Our intercooler is designed to fit like factory but be a more optimal and overall better performing unit. Under conditions in which the horsepower of the vehicle is increased, this unit is rated for 600HP.

Required Maintenance

PRL Motorsports thoroughly recommends visually inspecting your products during any routine maintenance like oil changes, tire rotations, and filter changes or cleanings. Please make sure to check your connections on all mounted parts periodically to ensure that they have not come loose over time. Always make sure to not drive through any debris that can damage the fins of the intercooler. Nor drive over or into anything that could puncture or crack the intercooler.



1400 RANDALL COURT - UNIT 104
EXPORT, PENNSYLVANIA 15632

www.PRLMotorsports.com

Follow Us!
PRLMotorsports

