



RAZER KUNAI CHROMA

IMPORTANT PRODUCT INFORMATION GUIDE

Get form and function that blows you away. Meet the **Razer Kunai**— performance aRGB fans powered by Razer Chroma™ RGB with fan blade technology inspired by elite military aircraft for stealthy, high static pressure cooling, and addressable LEDs for unique case designs.

GETTING STARTED

Warning: Please turn off your PC before proceeding to avoid electric shocks. For safety purposes, please wear an anti-static wrist strap (not included) to avoid damaging the internal components of your PC.

i All other PC peripherals or components are for illustration purposes only; they are not included in this package and sold separately.

MOUNTING METHOD

Anti-Vibration rubber screws



OR



Mounting screws

1

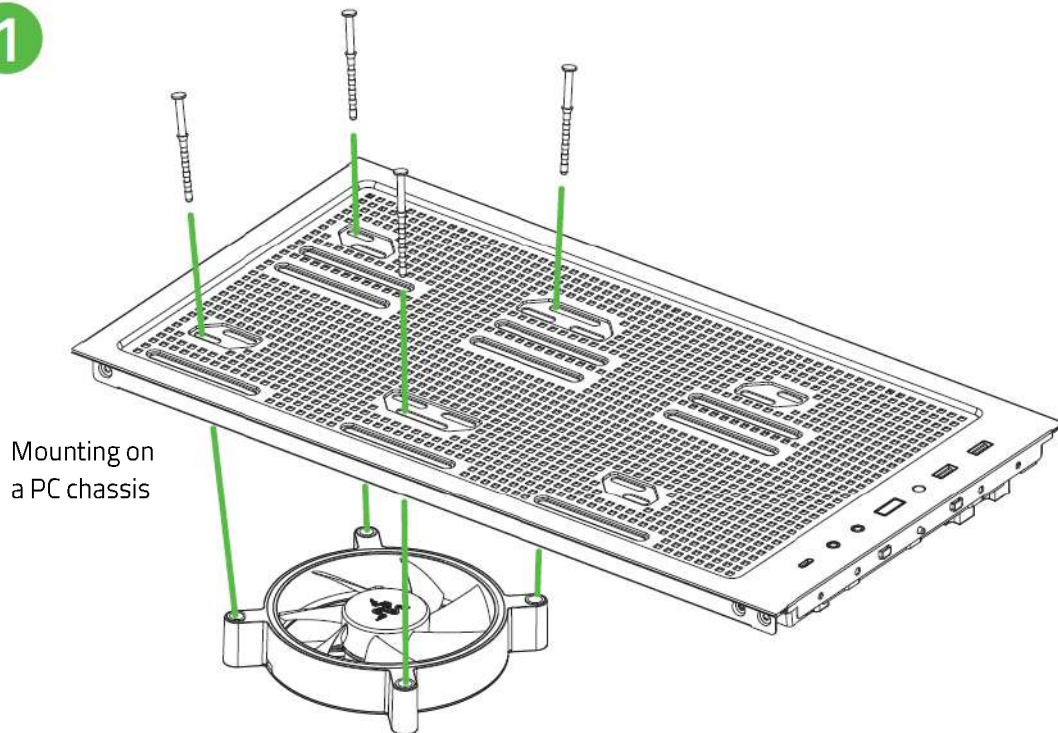

2

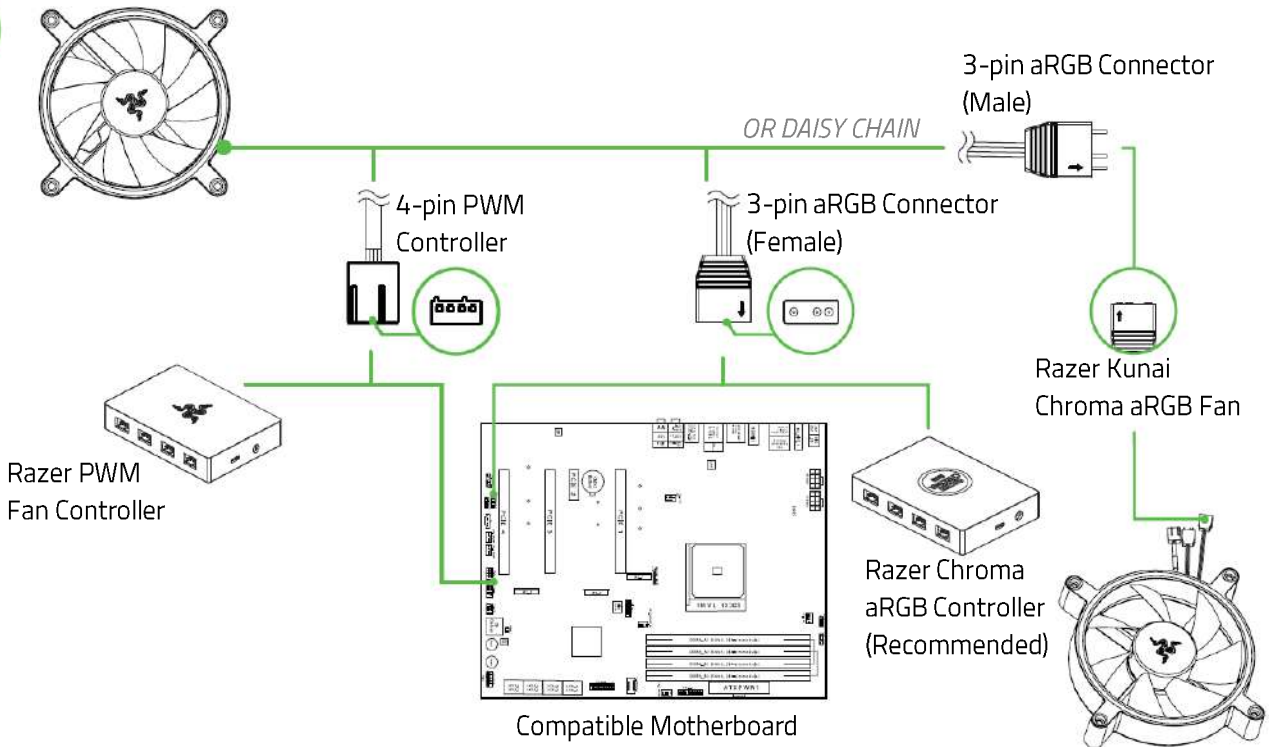

3



DOWNLOAD:
razer.com/synapse

i Install Razer Synapse when prompted or download the installer from razer.com/synapse

Got a question? Ask the Razer Support Team at support.razer.com

SAFETY AND MAINTENANCE

SAFETY GUIDELINES

In order to achieve maximum safety while using your Razer Kunai Chroma, we suggest that you adopt the following guidelines:

- Should you have trouble operating the device properly and troubleshooting does not work, unplug the device and contact the Razer hotline or go to support.razer.com for support. Don't attempt to service or fix the device yourself at any time.
- Don't take apart the device and don't attempt to operate it under abnormal current loads. Doing so may void your warranty.
- Only use accessories provided with the device and only purchase accessories made and/or approved by Razer.
- Power off the device before making any relocation, modifications, and/or connecting/disconnecting any component.
- Always handle all included accessories with care. When plugging or unplugging any accessory, always grip its plug/connector.
- Don't use or install the device and its components near water, moisture, solvents, or other wet surfaces, nor expose these components to high temperatures or direct sunlight.
- Keep the device and its components away from liquid, humidity or moisture. Operate the device and its components only within the specific temperature range of 0°C (32°F) to 45°C (113°F). Should the temperature exceed this range, unplug and switch off the device in order to let the temperature stabilize to an optimal level.

LEGALESE

COPYRIGHT AND INTELLECTUAL PROPERTY INFORMATION

©2021 Razer Inc. All rights reserved. Razer, the triple-headed snake logo, Razer logo, “For Gamers. By Gamers.”, and “Razer Chroma” logo are trademarks or registered trademarks of Razer Inc. or affiliated companies in the United States and other countries. All other trademarks are the property of their respective owners.

Windows and the Windows logo are trademarks of the Microsoft group of companies.

Razer Inc. (“Razer”) may have copyright, trademarks, trade secrets, patents, patent applications, or other intellectual property rights (whether registered or unregistered) concerning the product in this guide. Furnishing of this guide does not give you a license to any such copyright, trademark, patent or other intellectual property right. The Razer Kunai Chroma (the “Product”) may differ from pictures whether on packaging or otherwise. Razer assumes no responsibility for such differences or for any errors that may appear. Information contained herein is subject to change without notice.

LIMITED PRODUCT WARRANTY

For the latest and current terms of the Limited Product Warranty, please visit razer.com/warranty.

LIMITATION OF LIABILITY

Razer shall in no event be liable for any lost profits, loss of information or data, special, incidental, indirect, punitive or consequential or incidental damages, arising in any way out of distribution of, sale of, resale of, use of, or inability to use the Product. In no event shall Razer’s liability exceed the retail purchase price of the Product.

GENERAL

These terms shall be governed by and construed under the laws of the jurisdiction in which the Product was purchased. If any term herein is held to be invalid or unenforceable, then such term (in so far as it is invalid or unenforceable) shall be given no effect and deemed to be excluded without invalidating any of the remaining terms. Razer reserves the right to amend any term at any time without notice.