

FIT A TOW-PRO FORD RANGER WIRING KIT TO A 22MY NEXT-GEN FORD RANGER

These instructions relate to the installation of the REDARC Tow-Pro Elite into a 22MY Next-Gen Ford Ranger using the REDARC Tow-Pro Ford Ranger wiring kit. These instructions only cover the differences in mounting the main unit and remote head. For all other installation instructions, please refer to the Tow-Pro Ford Ranger wiring kit instruction manual.

MAIN UNIT MOUNTING

1. Fit the Tow-Pro mounting bracket to the main unit and bend down 90 degrees as shown, close to the fitting.

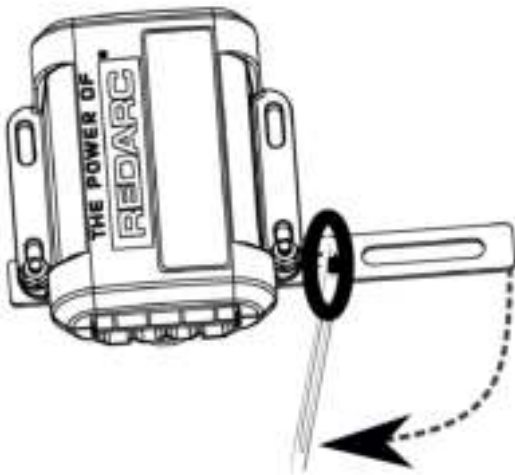

2. Fit the main unit to the left-hand side of the glove box using the supplied M6 nut and bolt, in the location indicated.

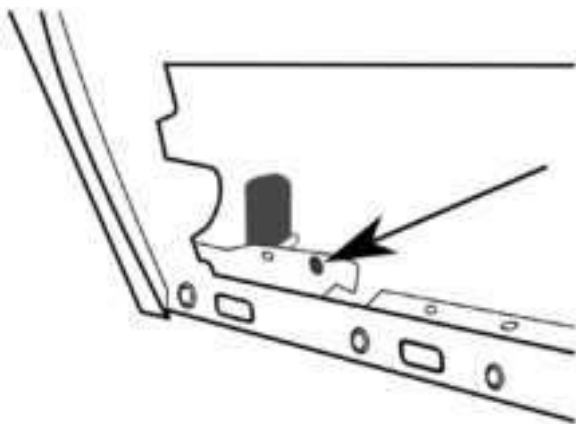

REMOTE HEAD POSITIONING

Bi-turbo model

Remove the gearshift trim (shaded in image). Please note; the clips can be difficult in the front corners (indicated by the dotted circle). Remove the three fixings exposed to lift the complete panel to fit the remote head. Bi-turbo model shown.



Standard model

The complete panel can be removed in a single piece. For guidance on where to mount the remote head, see the remote head positioning template on the following page. Please note, the below image is not to scale.

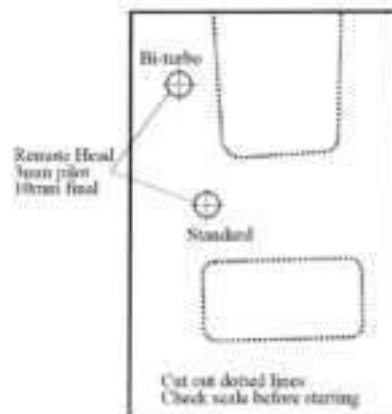

Please note; the template was produced from a Bi-Turbo model installation. Applications with manual transmission or other trim options may have slight differences and the mounting of the remote head is up to the installer.

FORD RANGER 22MY REMOTE HEAD DRILLING TEMPLATE



Bi-turbo
model
shown

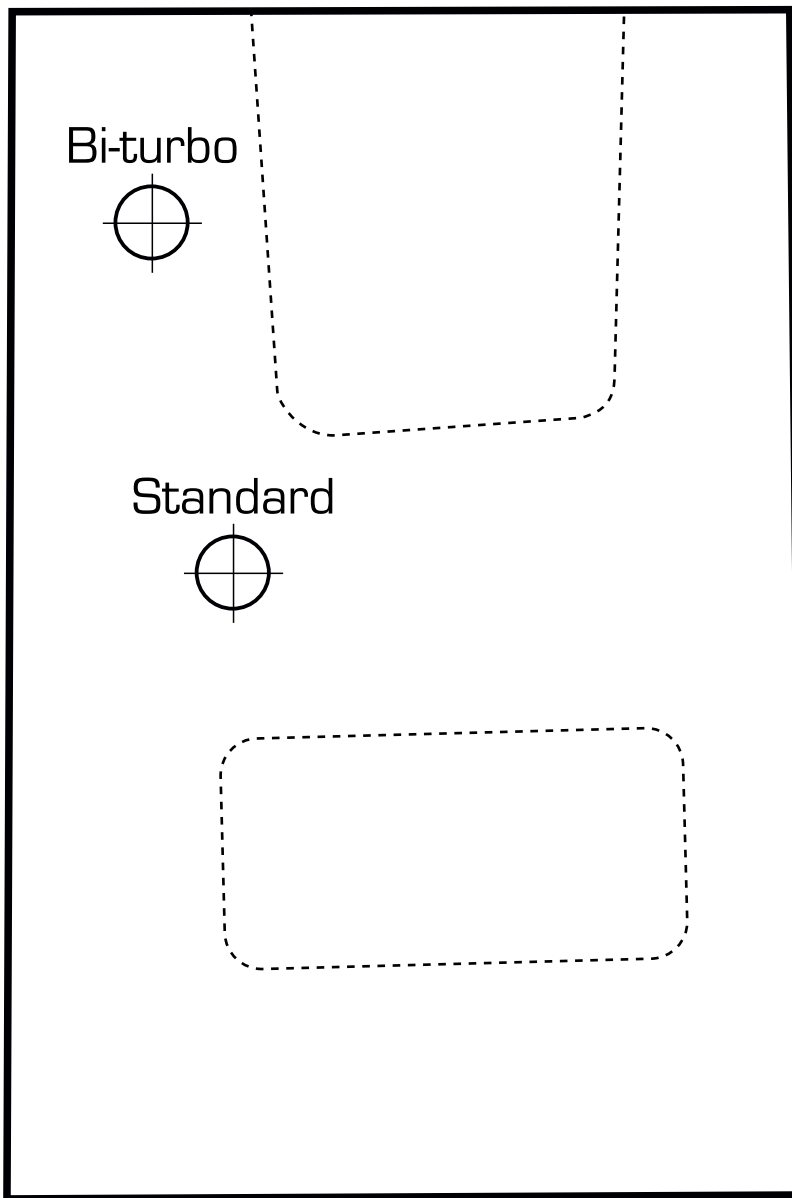

Remote head
locations
3mm pilot
10mm final

Cut out dotted lines
Check scale before starting

