

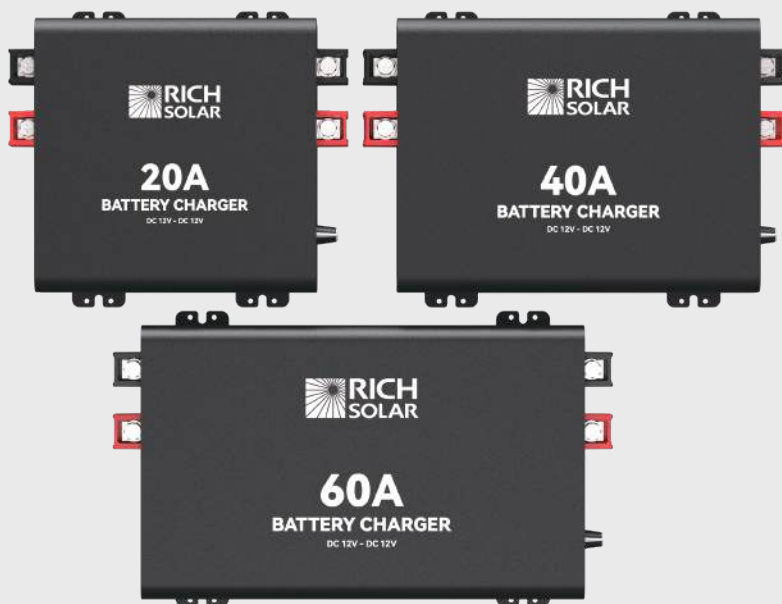

DC 12V - DC 12V BATTERY CHARGER

USER MANUAL



MODEL: RS-DC20 / RS-DC40 / RS-DC60

THIS MANUAL CONTAINS IMPORTANT SAFETY AND OPERATING INSTRUCTIONS FOR BATTERY CHARGER.
PLEASE READ THIS MANUAL AND FOLLOW THE INSTRUCTIONS EXACTLY.

Table of Contents

Important Safety Instructions	01
General Information	03
Product Overview	04
Identification of Parts	04
Dimensions	05
Optional Components	05
Installation	06
Location Considerations	06
Installation	06
Wiring and Fusing	07
Grounding	07
DC Output Wiring (House)	08
DC Input Wiring (Starter)	09
D+ Ignition Wiring	10
LC Current Limit Wiring	12
Operation	13
LED Indicators	13
Setting Battery Type	13
Battery Charging Logic	15
Lithium Activation	15
Troubleshooting	16
Maintenance	19
Technical Specifications	20
Temperature Compensation	20



Important Safety Instructions

Please save these instructions.

This manual contains important safety, installation, and operating instructions for the charger. The following symbols are used throughout the manual to indicate potentially dangerous conditions or important notes.

WARNING	Indicates a potentially dangerous condition. Use extreme caution when performing this task.
CAUTION	Indicates a critical procedure for the safe and proper installation and operation of the controller.
NOTE	Indicates a procedure or function that is important to the safe and proper operation of the controller.

The manufacturer accepts no liability for damage caused by:

- Faulty assembly or connection.
- Damage resulting from mechanical influences or excessive voltage.
- Modification or tampering with the unit without expressed permission from the manufacturer.
- Used for purposes other than those described in this manual.

General Safety

Warning — Risk of electric shock, fire hazard, or injury. To minimize risk:

- Ensure the positive and negative terminals of the charger do not come into contact.
- Firmly secure all cables and connections.
- Disconnect the product from the battery each time before cleaning or making changes to the circuit.
- Do not use the product if physically damaged or if cables are visibly cracked. Contact the manufacturer or customer service to prevent safety hazards.
- Do not attempt to repair the charger. Inadequate repairs may cause serious injury.
- Electrical devices are not toys—keep away from children.

Installation Safety

- This charger is for 12V battery banks only. Make sure your voltage specification is within the input voltage range specified.
- Install and store the product in a dry and cool place. Keep away from liquids! Do not expose the product to heat sources such as direct sunlight or other heating elements.

- Never mount in areas with high levels of dust or gas-explosion risk!
- Ensure secure location where it cannot tip over or fall.
- For installation on boats: if electrical devices are incorrectly connected, this can lead to corrosion damage on the boat. Verify installation with a qualified electrician or installer.
- Lay cables so they cannot be damaged by doors or be a tripping hazard. Damaged cables can lead to serious injury.
- Use ductwork or cable conduits if necessary, to lay cables through metal plates or other panels.
- Do not lay AC and DC cable in the same conduit, and do not pull on the cables.

Operation Safety

- **Warning** — Explosion Risk! Batteries can give off explosive hydrogen gas that can be ignited by sparks or electrical connections. Make sure the area is well-ventilated.
- Do not operate in salty, wet, or damp environments; in the vicinity of corrosive fumes; in the vicinity of combustible materials; in areas with explosion risks.
- Please be aware that parts of this product may still produce voltage even after disconnection or fuse activation.
- Do not disconnect cables while the product is operating.

Battery Safety

- **Warning** — Explosion Risk! Batteries may contain corrosive acids or fumes. Avoid contact with battery acid. If your skin comes into contact with acid, thoroughly wash the affected area with water. Any other injuries should seek medical care.
- Avoid wearing metal objects such as watches or rings when working with batteries. Short circuit risk!
- Use only rechargeable deep cycle batteries. NEVER attempt to charge a frozen or defective battery.
- Wear goggles, gloves, or other protective clothing when working with batteries. Do not touch your eyes.
- Ensure proper cable sizing for batteries! Over-current protection devices should be on the positive line.
- Refer to your battery manufacturer's guidelines for maintenance and care.
- When removing a battery, power off all loads first, then disconnect it from the circuit before removing.

General Information

The DC-DC Series battery chargers are the most effective way to charge your auxiliary or house batteries from the alternator/starter battery. Compatible with smart or traditional alternator types, the DC-DC offers correct charging for AGM, Flooded, GEL, and even Lithium deep cycle batteries! Featuring a 3-stage battery charger and multiple electronic protections, owners can feel confident that their batteries are being charged optimally and automatically. Easily install the compact yet sturdy DC-DC on RVs, commercial vehicles, boats, yachts and many more applications.

Key Features

- Compatible with multiple 12V batteries: AGM, Flooded, GEL, Sealed, Lithium-iron Phosphate and Lithium-ion.
- Smart protections features, including Over-Voltage, Over-Temperature, and Reverse Polarity protection!
- Battery Isolation and Battery Charger in one.
- Compact yet built tough for all conditions.
- 3-Stage Battery Charger get your batteries to 100%.

Check the charging requirements from the battery manufacturer before charging your battery with this unit.

Product Overview

Identification of Parts

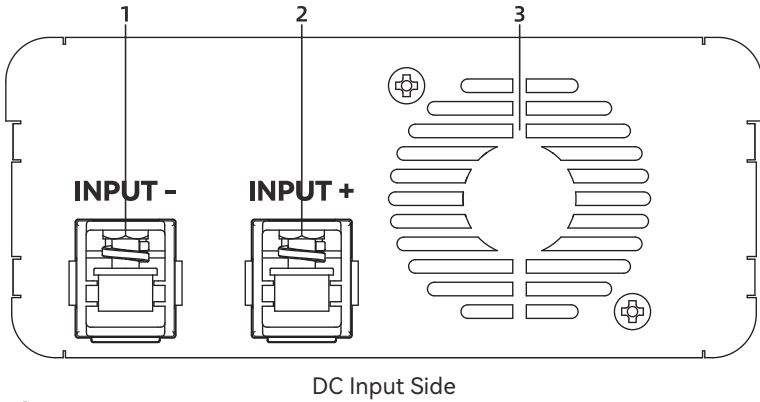

DC Input Side

Key Features

1. Negative DC Input Terminal.
2. Positive DC Input Terminal.
3. Ventilation Fans.

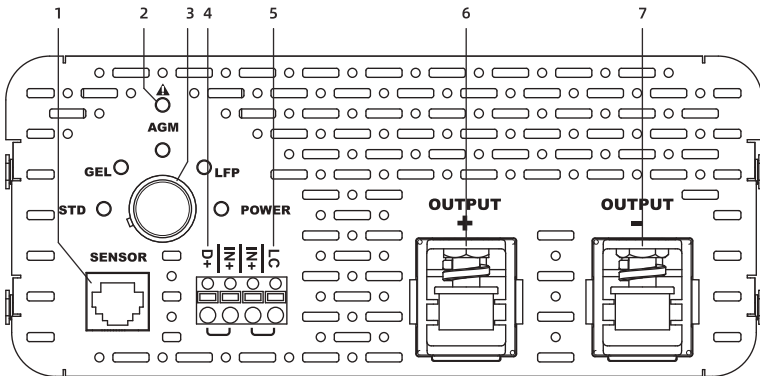

DC Output Side

Key Features

1. RJ11 Temperature Sensor Port (Requires separate purchase).
2. ERROR LED.
3. Battery Type Switching.
4. D+ Ignition Terminal.
5. LC Terminal-Current Limiting Terminal.
6. Positive DC Output Terminal.
7. Negative DC Output Terminal.

Dimensions

RS-DC20

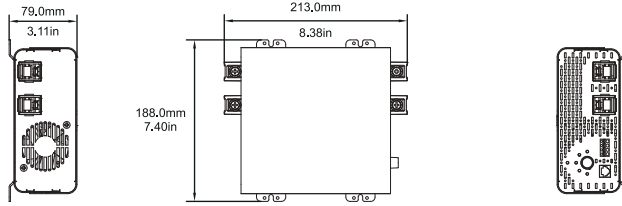

RS-DC40

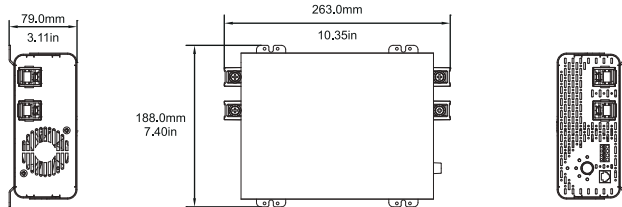

RS-DC60

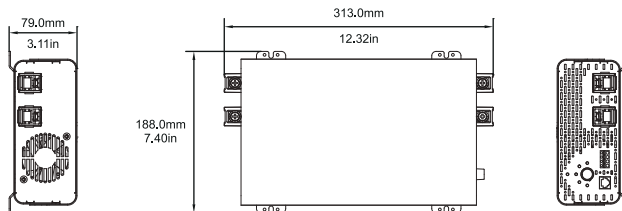

NOTE: The dimensions have a $\pm 0.5\text{mm}$ tolerance.

Optional Components

DC-DC Temperature Sensor



CAUTION — Do not use with Lithium batteries.

The DC-DC comes in handy for reading incoming temperature values from the house battery bank while adjusting the charging voltage of your DC to DC On-Board Battery Charger. Featuring an operation temperature range from $-20\sim 80^{\circ}\text{C}/-4\sim 176^{\circ}\text{F}$, the sensor will be important in the overall lifespan and performance of your house battery bank by applying higher charging voltage to counter the increased resistance due to low temperatures. Simply connect the DC-DC to the charger and place the sensor on top or on the side of the house battery bank and the charger will take care of the rest with temperature compensation.

Installation

DANGER — Cannot tip over or fall down.

CAUTION — Avoid additional heating of the product.

NOTICE — For installations in small, enclosed spaces, the minimum clearance around the battery charger must be at least 5cm/1.97”.

Location Considerations

When selecting a location for the DC-DC, make sure that it is as close as possible to the battery you will be charging (auxiliary battery). The charger may be mounted on the cabin of the vehicle, along a chassis rail, the inner guard of a vehicle, behind the grille or headlight, or even on the side of the radiator. However, make sure that the area is not susceptible to moisture or other substances as well as potentially high temperatures.

The DC-DC would operate best if there is some air flow.

Installation

- Have at least 5cm/1.97” of clearance on all sides and ensure some ventilation for best performance.
- Trace the mounting holes with a pencil/pen when placing the DC-DC against the desired area.
- Use 4×screws to secure the DC-DC onto a surface.

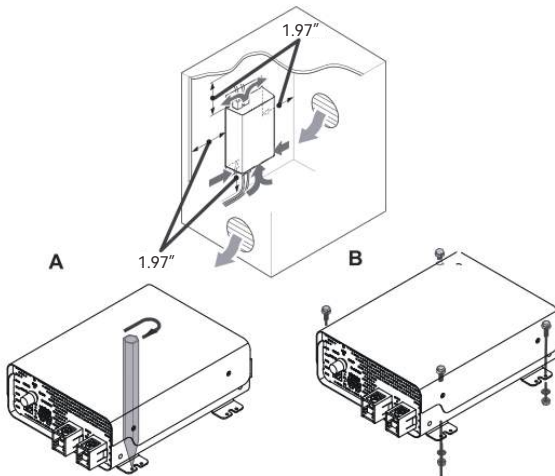

Wiring and Fusing

Battery Ring terminals are recommended for 12V input and output connections. The following is a reference incorporating a critical 0-3% max voltage drop and may not cover all unique applications that may exist. When the battery charger is sending the rated current, the input side may experience a higher current draw by a factor of up to 50%. Larger wire sizes generally improve performance, whereas smaller wire sizes may reduce performance, especially if undersized. When considering wiring, fusing, and connection options, prioritize shorter and thicker wires—they offer less resistance and lower voltage drop. Terminal Size Limitations may apply. The installer is responsible for ensuring that the correct cable and fuse sizes are used when installing the DC-DC battery charger.

Model	Cable	Cable Length/Min AWG			Recommended Fuse
		0~10ft/ 0~3m	11~20ft/ 3 ~ 6m	21~30ft/ 6~9m	
RS-DC20	To DC Input (Starter)	10AWG	8-6AWG	6-4AWG	30A
	To DC Output (House)	12AWG	10-8AWG	6AWG	25A
RS-DC40	To DC Input (Starter)	6AWG	4AWG	4AWG*	60A
	To DC Output (House)	8AWG	8-6AWG	4AWG	50A
RS-DC60	To DC Input (Starter)	4AWG	4AWG*	4AWG*	90A
	To DC Output (House)	6AWG	4AWG	4AWG*	75A

* 3-10% Non-Critical Voltage Drop

Grounding

NOTE: Depending on the application, the grounding point may differ.

The DC-DC shares a common negative ground, meaning there should be only one common ground point between all batteries and electronics. This is typically seen in either the chassis/body ground, a canopy, a trailer, or even the vehicle's battery negative connection. In most cases, connecting the starter and house battery directly to the DC-DC is enough for grounding. You will not ground the body of the DC-DC. In the illustration below, the two batteries are connected to the same chassis ground point.

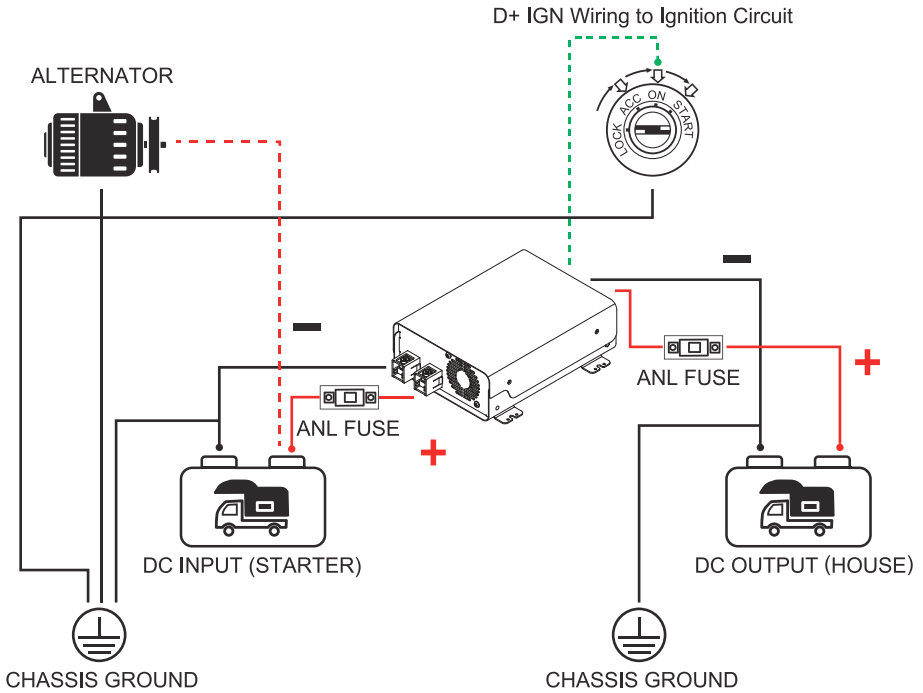

DC Output Wiring (House)

Warning — Only use 12V batteries. Damages due to connecting higher voltage batteries will not be covered under warranty.

The DC-DC output will connect to the 12V auxiliary or house battery that you are intending to charge. These batteries may be a different chemistry from the starter battery. The DC-DC input and output terminals are isolated, meaning that the output voltage can be kept stable without interference from the input circuit. This ensures stable and correct charging of auxiliary batteries. It is best to place the DC-DC closer to the battery you will be charging primarily.

1. Use a screwdriver to loosen the DC output terminals by rotating counterclockwise (CCW).
2. Connect a ring terminal cable from House Battery Positive to the Positive DC Output Terminal.
3. Use a screwdriver to tighten the DC output terminal by rotating clockwise (CW).
4. Repeat for the House Battery Negative to the Negative DC Output Terminal.

1 counterclockwise

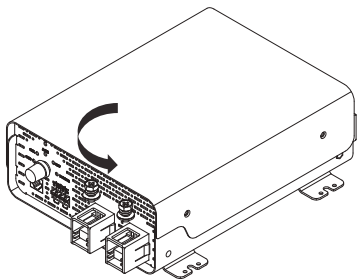

2

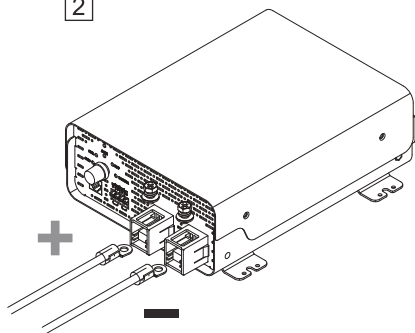

3 clockwise

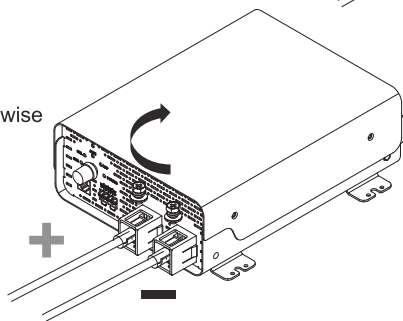

DC Input Wiring (Starter)

The DC-DC will not power on or operate until the D+ ignition cable is connected. When connecting the DC input, note that the DC-DC will still be off until the ignition cable voltage is detected.

The DC-DC input will connect to the 12V starter battery that will be used to charge your auxiliary or house battery. The starter battery may be a different chemistry from the house battery. The DC-DC input and output terminals are isolated, meaning that the output voltage can be kept stable without interference from the input circuit. This ensures stable and correct charging of auxiliary batteries.

1. Use a screwdriver to loosen the DC input terminals by rotating counterclockwise (CCW).
2. Connect a ring terminal cable from Starter Battery Positive to the Positive DC Input Terminal.
3. Use a screwdriver to tighten the DC Input terminal by rotating clockwise (CW).
4. Repeat for the Starter Battery Negative to the Negative DC Input Terminal.

1 counterclockwise

2

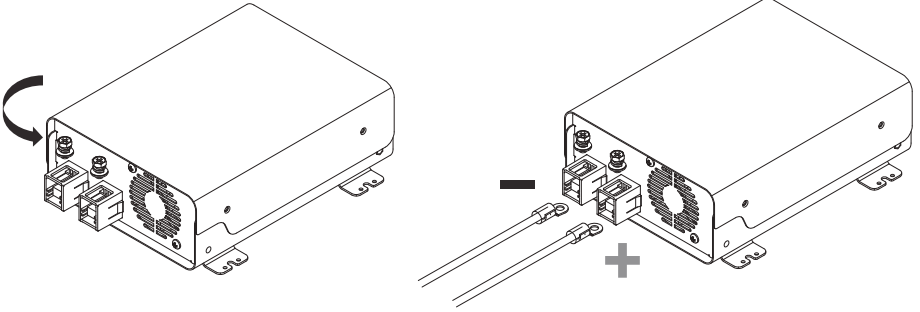

3 clockwise

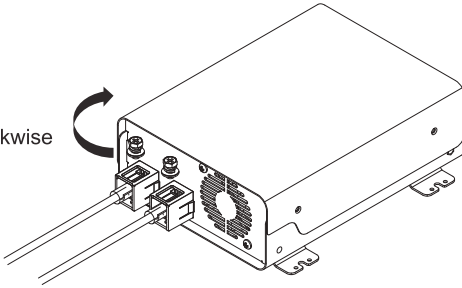

D+ Ignition Wiring

The D+ terminal will be located on the output side but connects to the DC ignition circuit of the input starter battery. This may be in the engine bay fuse block for some vehicles. Refer to your vehicle's electrical diagram for D+ wiring placement. It may require splicing or cable adjustments to connect correctly to your ignition circuit.

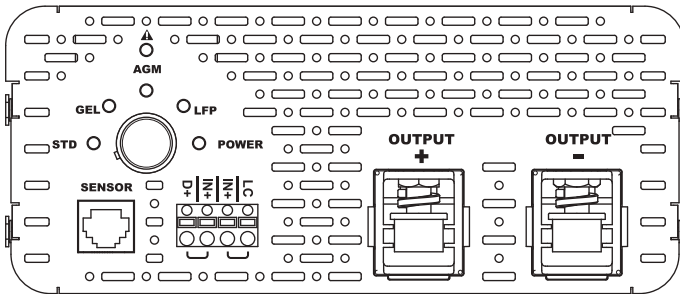

18-16AWG, solid copper cable recommended

The DC-DC will not power on or operate until the D+ ignition cable is connected to the ignition circuit, where it will detect a 12V source to operate ON. The purpose is to toggle the DC-DC switch on when the vehicle is running with the alternator, preventing the DC-DC from operating incorrectly with just the starter battery, which could leave you with a drained starter battery. Use 18-16AWG solid copper cable. You may need a multi-meter to test your connections and verify the placement of the D+ wire.

Alternator Recommendation

Check your alternator and identify the number of terminals. Most alternators will have 3 wires connected (BATT+, BATT-, IGN). The following is an example and may not match your application. Refer to your vehicle's documentation and parts for the actual wiring.

①	BATT+	Could be labeled as "B", "Bat", or "Pos". This will connect directly to the battery and typically be heavy gauge for high current applications.
②	BATT-	Could be labeled as "Neg", "Field" or "F". This will connect to ground. Some alternators may not have this as they will be directly grounded to the engine.
③	IGN	Could be labeled "IGN" or "L" and will likely be the smaller terminal. This connects to the ignition circuit or dashboard warnings signs. This is where you will want to splice the D+ ignition cable.

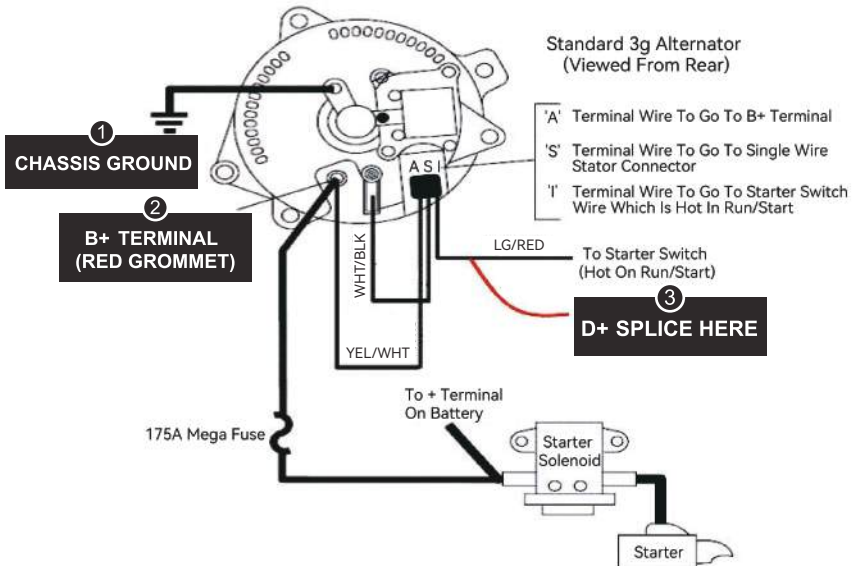

Engine Bay Fuse Block Recommendation

Review your vehicle's fuse layout diagram to identify a fuse location that is live when the vehicle is running with the alternator. Key positions in the ignition are typically lock, accessory, on, and start.

LOCK	Off position where no accessories will work, and steering is also likely locked.
ACCESSORY	Accessories are given power, such as radio and some other small electronics.
ON	Turns on all your electronics. The key will default into this position after cranking in START. Splicing of fuse block will need to be live when the key is in reverting back to this position.
START	Cranks the engine on and reverts to ON position.

You may need to test the fuse location by checking the voltage with a multi-meter and making sure it's live only when the vehicle is in the Start/Run position. This will help in identifying where to connect if the fuse layout does not have an IGN position. The easiest connections when splicing can be made using a fuse holder splice connector.

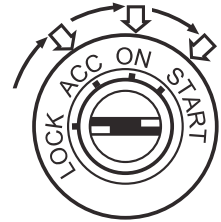

LC Current Limit Wiring

The DC-DC battery charger (D+) and (IN+) can be powered on by short circuiting, or connected to the same position as the ignition cable (D+). When connecting the LC terminal to a 12V power supply, the DC-DC battery charger has a 50% current limit of the rated specification. The current limit is instantaneous and it is recommended to connect to the same location as the D+ ignition cable. Alternatively, you can connect the LC terminal to the positive terminal of the starter battery according to your preferences, limiting the current in this way until the LC wire is removed from the battery terminal to restore the normal rated current. Using an 18-16AWG solid copper cable as the LC terminal, depending on your connection point, you may need to splice your own connection to another cable end.

Model	Amp Rating	Current Limit
RS-DC20	20A	10A
RS-DC40	40A	20A
RS-DC60	60A	30A

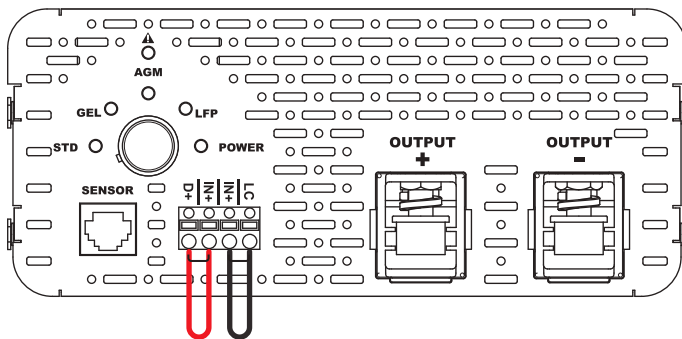

18-16AWG, solid copper cable recommended

Operation

Assuming correct D+ ignition cable wiring, then the mode indicator will be on.

LED Indicator

Color	Status	Meaning
Red	Off	No faults
	Solid On	Fault detected; refer to troubleshooting

Setting Battery Type

WARNING — Refer to your battery manufacturer's specifications when selecting a battery type via mode selection switch. Damage due to incorrect battery settings will not be covered under warranty.

Mode Selection Switch

The battery types that can be set to charge are standard lead acid battery (STD battery), gel-sealed lead battery (GEL battery), AGM battery, Lithium iron phosphate battery (LFP battery).

- The mode selection switch (as shown in the figure below) can be configured to charge STD, GEL, AGM and LFP batteries (just point the white part of the switch to the corresponding indicator).

- STD, GEL, and AGM have absorption charging and float charging.
- LFP has an absorption charging, but no float charging.
- The POWER mode can be used as a power supply.

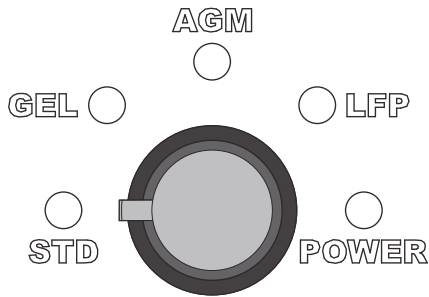

Product model		RS-DC20	RS-DC40	RS-DC60
Battery type		Lead Acid / Li-ion / GEL / AGM		
Charging Voltage	STD Battery	14.4V±0.1V		
	GEL Battery	14.6V±0.1V		
	AGM Battery	14.8V±0.1V		
	LFP Battery	14.6V±0.1V		
	POWER Mode	13.2V±0.1V		
Float Charging Voltage	STD Battery	13.5V±0.1V		
	GEL Battery	13.5V±0.1V		
	AGM Battery	13.8V±0.1V		
	LFP Battery	N/A		
	POWER Mode	N/A		

Battery Charging Logic

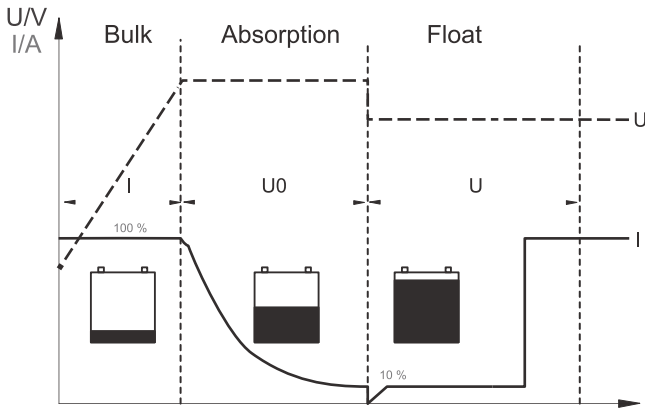

Bulk (Phase I) (Lead Acid+Lithium)

In the beginning, a discharged battery will be charged with maximum current, and the voltage will climb steadily until reaching the absorption voltage setpoint.

Absorption (Phase U0) (Lead Acid+Lithium)

The battery reaches the absorption voltage setpoint and holds the voltage constant while the current gradually decreases until the battery is becoming full (within 10–20%). By default, absorption will not exceed 3 hours to prevent overcharging.

Float (Phase U) (Only Lead Acid)

After the absorption stage, the voltage of the battery will reduce to the float voltage setpoint, and the current will also reduce to a low maintenance mode to prevent the battery from discharging and offsetting any self-discharge. Heavier battery discharge may set the controller back to Bulk/Absorption to replenish the energy lost while energy is available.

Lithium Activation

NOTE: This is an automatic process for Lithium batteries. Ensure correct lithium polarity when connecting to the DC Output.

The DC-DC has a reactivation feature to awaken a sleeping lithium battery. The protection circuit of Lithium batteries will typically turn the battery off and make it unusable if over-discharged.

This can happen when storing a Lithium pack in a discharged state for any length of time, as self-discharge would gradually deplete the remaining charge. Without the wake-up feature to reactivate and recharge the batteries, these batteries would become unserviceable and the packs would be discarded. A small charge current will be applied to the house battery to activate the protection circuit, and if a correct cell voltage can be reached, it starts a normal charge.

Troubleshooting

If the DC-DC is not functioning correctly, it may be undergoing an internal electronic protection and stop normal operation. This is not indicative of a defective unit but may require some troubleshooting to resume normal operation.

Electronic Protection

Behavior	Protection	Troubleshoot Steps				
Red Fault LED ON	Battery Overvoltage	<p>1. Use a multi-meter to measure the DC input and DC output batteries as well as the respective DC-DC input/output terminals. Battery overvoltage is 15.5-16V:</p> <table border="1" data-bbox="402 943 958 1050"> <tr> <td data-bbox="402 943 682 995">High Voltage Shutdown</td> <td data-bbox="682 943 958 995">16V</td> </tr> <tr> <td data-bbox="402 995 682 1050">High Voltage Restart</td> <td data-bbox="682 995 958 1050">15.5V</td> </tr> </table> <p>2. Disconnect any other chargers in the circuit and let the battery rest to lower the voltage. Disconnect any sensitive loads.</p> <p>3. Check whether the battery switch is in the same position as the battery indicator.</p>	High Voltage Shutdown	16V	High Voltage Restart	15.5V
High Voltage Shutdown	16V					
High Voltage Restart	15.5V					

Behavior	Protection	Troubleshoot Steps				
Red Fault LED ON	Battery Undervoltage	<p>1. Use a multi-meter to measure the DC input and DC output batteries as well as the respective DC-DC input/output terminals. They should be similar. Battery undervoltage is below 8-10V.</p> <table border="1" data-bbox="405 331 960 437"> <tr> <td data-bbox="405 331 684 384">Low Voltage Cut-out</td> <td data-bbox="684 331 960 384">8V (Lead Acid)</td> </tr> <tr> <td data-bbox="405 384 684 437">Low Voltage Restart</td> <td data-bbox="684 384 960 437">10V</td> </tr> </table> <p>2. Disconnect any other loads in the circuit and let the battery charge.</p> <p>3. Lead acid batteries below 8V may need an external charger to reach minimum DC-DC voltages; Lithium batteries will be able to recover due to Lithium Activation.</p>	Low Voltage Cut-out	8V (Lead Acid)	Low Voltage Restart	10V
	Low Voltage Cut-out	8V (Lead Acid)				
	Low Voltage Restart	10V				
Polarity Reverse	<p>1. Use a multi-meter in DC Volts and probe the positive line onto the positive battery terminal and probe the negative line to the negative battery terminal. You should see a reading within 10V~14V and be a positive number.</p> <p>2. If the DC reading is negative, your poles are reversed. Fix the wiring to return to normal operation.</p> <p>WARNING — Lithium batteries in reverse polarity may cause irreversible damage to the DC-DC.</p>					
High Temperature	<p>1. Double check that your wiring is correct with a multi-meter and that the battery levels are suitable within the operating voltage range.</p> <p>2. Observe the ambient temperature. Avoid installations in direct sun. Ambient temperatures above 50°C/122°F will cause the unit to stop functioning until conditions get cooler.</p> <p>3. Move the unit to a cooler location or introduce ventilation into the installation location. The protection is automatic, and the DC-DC will resume normal function upon cooling down.</p>					

Behavior	Protection	Troubleshoot Steps
Red Fault LED ON	Short Circuit	<ol style="list-style-type: none"> 1. The DC-DC is experiencing an internal short circuit due to an imbalance between its input and output circuits. Restart the DC-DC by disconnecting the input/output and then reconnecting it again. 2. The error will clear automatically upon a successful restart. If issues continue with a permanent Red LED, then contact support to address the previous troubleshooting steps.

More Troubleshooting

Behavior	Cause	Fix
ALL Indicator LED OFF	Incorrect D+ Connection	<ol style="list-style-type: none"> 1. Check to make sure there is a cable connected between the D+ Terminal (DC Output Side) and the ignition circuit. The D+ needs a 12V signal to start/stop the DC-DC. Splicing required. Refer to your vehicle's fuse box layout to identify the ignition line or similar location that is live when the alternator is running.
	Wrong Battery at Input/Output	<ol style="list-style-type: none"> 1. Verify correct battery placement with tight and secure connections, eliminate any breaks. 2. DC Input terminals should be the starting battery and should also have a charging source (alternator in this case). 3. DC output terminals should be the auxiliary or house battery you're charging.

Behavior	Cause	Fix
ALL Indicator LED OFF	Battery Voltage too Low or High	<p>1. The DC-DC requires 12V batteries more than 10V (Lead Acid) and can not exceed 15.5V, so no 24V batteries.</p> <p>Use a multi-meter to measure the battery terminals and verify that the DC-DC terminals match the respective values (or similar). Continued problems with batteries may need to be taken to a nearby battery tester at your nearby automotive shop.</p>
	Connection Break	<p>1. Inspect your connections for tight, secure, and undamaged wiring to and from the DC-DC.</p> <p>2. Check fuses for any breaks and replace them to continue normal operation.</p> <p>3. Use your multi-meter's (check with manufacturer) continuity test to individually check each line (positive and negative) at the input and output to verify consistent connection. Audible multi-meter Beeps indicate continuity. No sound indicates connection break.</p>

Maintenance

For best DC-DC performance, periodically check the unit and related wiring monthly as well as the installation location:

1. Inspect the wiring and note any wiring cracks, wear, tear, corrosion, or loose wiring and replace immediately. Inspect wiring terminals and ensure they're tight as they may become loose during vehicle vibrations.
2. Check that the battery charger is free of dust, liquids, or heat sources and ensure the DC-DC is receiving some ventilation. Improved ventilation improves performance.

Technical Specifications

Mode	RS-DC20	RS-DC40	RS-DC60
Output nominal power	250W	500W	750W
Output nominal current	20A	40A	60A
Operating current range	18~22A	37~43A	56~65A
Low current mode	10A	20A	30A
Float charging current	1.5-3A	3-5A	4.5-7.5A
Low current mode current range	8~11A	18~22A	27~32A
Quiescent current	<0.45A	<0.6A	<0.75A
Ripple voltage	<500 mV RMS		
Battery charging mode	3-stage type		
Efficiency	>85%, @ 14VDC, 30% load		
Input nominal voltage	12VDC		
Operating voltage range	10~16VDC		
Input current limiting	≤34A	≤68A	≤100A

Temperature Compensation

NOTE: The temperature compensation is not to be used with lithium batteries.

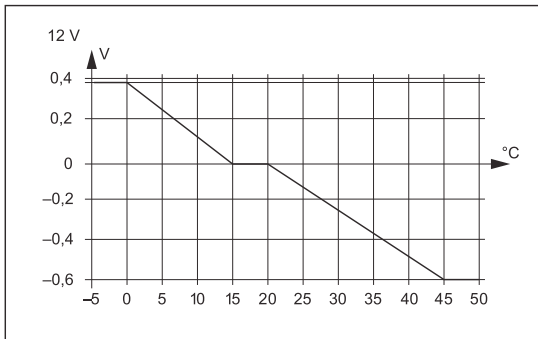

 1-800-831-9889

 support@richsolar.com

 www.richsolar.com

 1900 Mountain Ave, Norco, CA 92860