

Ronix®

Premium Quality

ELECTRIC DRILL 13MM 2214

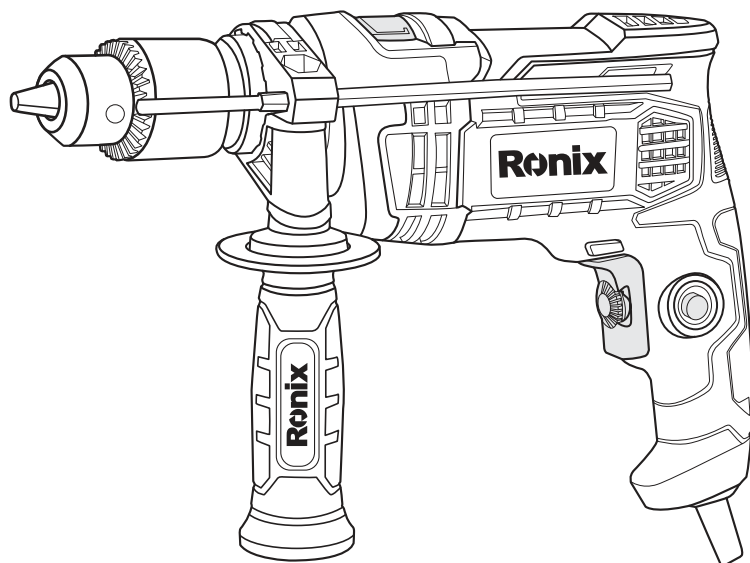

www.ronixtools.com

12
MONTHS
GUARANTY

FREE
DELIVERY

BANK
SPARE PARTS

CALL
CENTER
02161904

SPECIFICATION

Model	2214
Rated power	750W
Rated voltage	220-240V
Frequency	50-60Hz
Action mode	Impact Drill
Chuck size	13mm
Chuck Type	Keyed
Max Impact Rate	48000 BPM
No load speed	0-2800rpm
Drilling capacity	Wood: 25mm Steel: 13mm Concrete: 13mm
Net weight	2Kg
Supplied in	Ronix Color box
Includes	Auxiliary Ronix-design handle, chuck key, Depth guage, Pair of carbon brushes

PART LIST

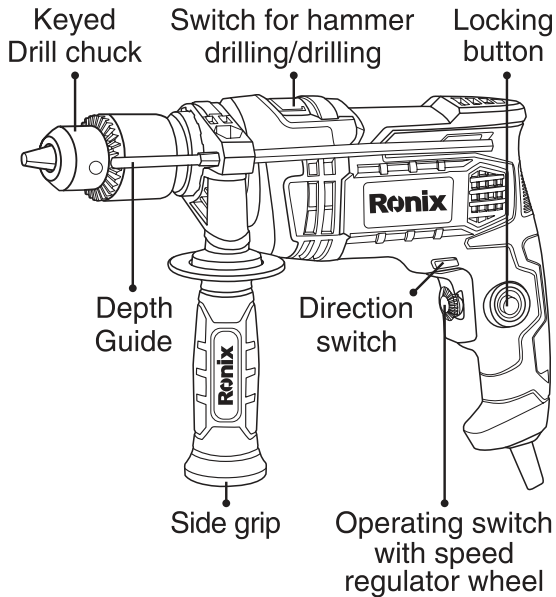

GENERAL POWER TOOL SAFETY WARNINGS

WARNING!

- Read all safety warnings and all instructions. Failure to follow the warnings and instructions may result in electric shock, fire and or serious injury.
- Save all warnings and instructions for future reference.

■ WORK AREA SAFETY

- Keep work area clean and well lit. Cluttered or dark areas invite accidents.
- Don't operate power tools in explosive atmospheres, such as in the presence of flammable liquids, gases or dust. Power tools create sparks which may ignite the dust or fumes.
- Keep children and bystanders away while operating a power tool. Distractions can cause you to lose control.

■ ELECTRIC SAFETY

- Power tool plugs must match the outlet. Never modify the plug in any way.
- Don't use any adaptor plugs with earthed (grounded) power tools. Unmodified plugs and matching outlets will reduce risk of electric shock.
- Avoid body contact with earthed or grounded surfaces such as pipe, radiators, ranges and refrigerators. There is an increased risk of electric shock if your body is earthed or grounded.
- Don't expose power tools to rain or wet conditions. Water entering a power tool will increase the risk of electric shock.
- Don't abuse the cord. Never use the cord for carrying, pulling or unplugging the power tool. Keep cord away from heat, oil, sharp edges or moving parts. Damaged or entangled cords increased the risk of electric shock.
- When operating a power tool outdoors, use an extension cord suitable for outdoor use. Using a cord suitable for outdoor use will reduce the risk of electric shock.
- If operating a power tool in a damp location is unavoidable, use a residual current device (RCD) protected supply. Use of an RCD reduces the risk of electric shock.
- Use of power supply via a RCD with a rated residual current of 30mA or less is always recommended.

■ PERSONAL SAFETY

- Stay alert, watch what you are doing and use common sense when operating a power tool. Don't use a power tool while you are tired or under the influence of drugs, alcohol or medication. A moment of inattention while operating power tools may result in serious personal injury.
- Use personal protective equipment. Always wear eye protection. Protective equipment such as dust mask, non-skid safety shoes, hard hat, or hearing protection used for appropriate conditions will reduce personal injuries.
- Prevent unintentional starting. Ensure the switch is in the off-position before connecting to power source and/or battery pack, picking up or

carrying the tool. Carrying power tools with your finger on the switch or energizing power tools that have the switch on invites accidents.

- Remove any adjusting key or wrench before turning the power tool on. A wrench or a key left attached to a rotating part of the power tool may result in personal injury.
- Don't overreach. Keep proper footing and balance at all times. This enables better control of the power tool in unexpected situations.
- Dress properly. Don't wear loose clothing or jewelry. Keep your hair, clothing, and gloves away from moving parts. Loose cloths, jewelry or long hair can be caught in moving parts.
- If devices are provided for connection of dust extraction and collection facilities, ensure these are connected and properly used. Use of dust collection can reduce dust-related hazards.

POWER TOOL USE AND CARE

- Don't force the power tool. Use the correct power tool for your application. The correct power tool will do the job better and safer at the rate for which it was designed.
- Don't use the power tool if the switch doesn't turn it on and off. Any power tool that cannot be controlled with the switch is dangerous and must be repaired.
- Disconnect the plug from the power source and/or the battery pack from the power tool before making any adjustments, changing accessories, or storing power tools. Such preventive safety measures reduce the risk of starting the power tool accidentally.
- Store idle power tools out of the reach of children and don't allow persons unfamiliar with power tool or these instructions to operate the power tool. Power tools are dangerous in the hands of untrained users.
- Maintain power tools. Check for misalignment or binding of moving parts, breakage of parts and any other condition that may affect the power tool's operation. If damaged, have the power tool repaired before use. Many accidents are caused by poorly maintained power tools.
- Keep cutting tools sharp and clean. Properly maintained cutting tools

with sharp cutting edges are less likely to bind and are easier to control.

- Use the power tool, accessories and tool bits etc. in accordance with the instruction, taking into account the working conditions and the work to be performed. Use of the power tool for operations different from those intended could result in a hazardous situation.

SERVICE

- Have your power tool serviced by qualified repair person using only identical replacement parts. This will ensure that the safety of power tool is maintained.
- Follow instruction for lubricating and changing accessories.
- Keep handles dry, clean and free from oil and grease.

ELECTRIC DRILL SAFETY WARNINGS

- Wear ear protectors when impact drilling. Exposure to noise can cause hearing loss.
- Hold power tool by insulated gripping surface, when performing an operation where the cutting accessory may contact hidden wiring or its own cord. Cutting accessory contacting a “live” wire may make exposed metal parts of the power tool “live” and could give the operator and electric shock.
- Always be sure you have a firm footing. Be sure no one is below when using the tool in high locations.
- Hold the tool firmly with both hands.
- Keep hands away from rotating parts.
- Don't leave the tool running. Operate the tool only when hand-held.
- Don't touch the bit or the work piece immediately after operation; they may be extremely hot and cold burn your skin.
- Some material contains chemical which may be toxic. Take caution to prevent dust inhalation and skin contact. Follow material supplier safety data.

SPECIFIC SAFETY RULES

Don't let comfort or familiarity with product (gained from repeated use) replace strict adherence to impact drill safety rules. If you use this tool unsafely or incorrectly, you can suffer serious personal injury.

- Hold tool by insulated gripping surfaces when performing an operation where the cutting tools may contact hidden wiring or its own cord. Contact with "live" wire will make exposed metal parts of the tool "live" and shock the operator.
- Always be sure you have a firm footing. Be sure no one is below when using the tool in high locations.
- Hold the tool firmly with both hands. Always use the side grip.
- Keep hands away from rotating parts.
- Do not leave the tool running. Operate the tool only when hand-held.
- Don't touch the drill bit or the work piece immediately after operation; they may be extremely hot and could burn your skin.
- Be sure the bit is secured in place before operation.
- Some material contains chemicals which may be toxic. Take caution to prevent dust inhalation and skin contact. Follow material supplier safety data.

FUNCTIONAL DESCRIPTION

WARNING!

Always be sure that the tool is switched off and unplugged before installing or removing the bit.

■ INSTALLING AND REMOVING THE BIT

- 1) To install the bit, place it in the chuck as far as it will go. Tighten the chuck by hand. Place the chuck key in each of the three holes and tighten clockwise. Be sure to tighten all three chuck holes evenly.
- 2) To remove the bit, turn the chuck key counterclockwise in just one hole, then loosen the chuck by hand.
- 3) After using the chuck key, be sure to return to the original position.

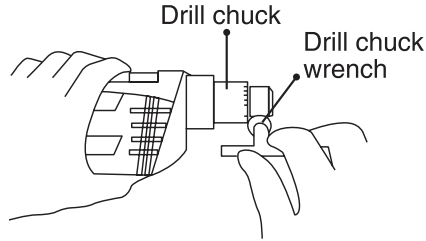

■ SIDE HANDLE

The tool is equipped with side grip before outgoing. The side grip swings around to either side, allowing easy handling of the tool in any position. Loosen the side grip by turning it counterclockwise, swing it to the desired position and then tighten it by turning clockwise.

■ DEPTH GAUGE

The depth gauge is convenient for drilling holes of uniform depth. Insert the depth gauge into the hole in the grip base. Adjust the depth gauge to the desired depth and then tighten the clamp screw to secure the depth gauge.

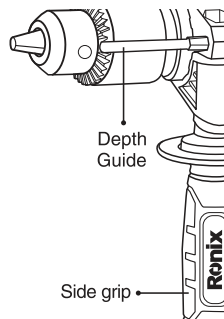

■ SWITCH ACTION

- 1) To start the tool, simply pull the switch trigger. Tool speed is increased by increasing pressure on the switch trigger. Release the switch trigger to stop.
- 2) For continuous operation, pull the switch trigger and then push in the lock button.

3) To stop the tool from the locked position, pull the switch trigger fully, then release it.

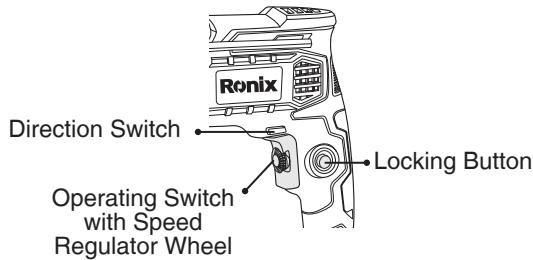

■ SELECT THE ACTION MODE

The tool has an action mode change lever. For rotation with hammering, slide the action mode change lever to the right (T symbol). For rotation only, slide the action mode change lever to the left (I symbol).

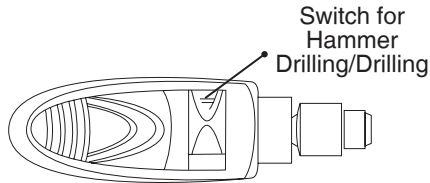

MAINTENANCE & DAILY CARE

⚠ CAUTION:

Always be sure that the is switch off and unplugging before attempting to perform inspection and maintenance.

- 1) The tool and its air vents have to be keep clean, regularly clean the tool's air vents or whenever the vents start to become obstructed.
- 2) Often check the all screws if be loosened or not periodically.
- 3) Often check the cord insulation if broken or not.

 **CAUTION:**

After replacing brushes, running tool with no load for about 10 minutes. Then check the tool while running, when releasing the switch trigger. If the tool is not working well, ask nearest RONIX SERVICE after sales center for repair.

To maintain product safety and reliability, repairs, carbon brushes inspection and replacement or any other maintenance or adjustment should be performed by RONIX SERVICE after sales centers, always using RONIX replacement parts.

Ronix[®]
Premium Quality

www.ronixtools.com