

# Lexium Servo Drive

17D HP Series  
User Guide

February 2005



---

---

**Preface**

The data and illustrations found in this book are not binding. We reserve the right to modify our products in line with our policy of continuous product development. The information in this document is subject to change without notice and should not be construed as a commitment by Schneider Electric.

Schneider Electric assumes no responsibility for any errors that may appear in this document. If you have any suggestions for improvements or amendments or have found errors in this publication, please notify us.

No part of this document may be reproduced in any form or by any means, electronic or mechanical, including photocopying, without express written permission of the Publisher, Schneider Electric.

**CAUTION!**

All pertinent state, regional, and local safety regulations must be observed when installing and using this product. For reasons of safety and to assure compliance with documented system data, repairs to components should be performed only by the manufacturer.

**Failure to observe this precaution can result in injury or equipment damage.**

MODSOFT® is a registered trademark of Schneider Electric

The following are trademarks of Schneider Electric:

Modbus    Modbus Plus    Modicon    984    Quantum

DIGITAL® and DEC® are registered trademarks of Compaq Computer Corp.

IBM® and IBM AT® are registered trademarks of International Business Machines Corporation.

Microsoft® and MS-DOS® and Windows® are registered trademarks of Microsoft Corporation.

©Copyright 2003, Schneider Electric



---

# Contents

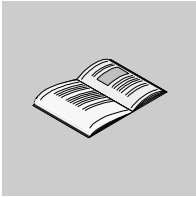

---

<b>Chapter 1 - Introduction</b>	<b>1</b>
At a Glance .....	1
Document Scope .....	1
What's in this Chapter .....	1
About this User Guide .....	2
Who Should Use this User Guide .....	2
How this User Guide Is Organized .....	2
Related System Components .....	4
Single-Axis Motion Control System .....	4
UniLink Commissioning Software for 17D HP .....	4
Related Documentation .....	5
Documents .....	5
Hazards, Warnings and Guidelines .....	6
Hazards and Warnings .....	6
Additional Safety Guidelines .....	9
Qualified Personnel .....	9
Standards and Compliances .....	10
European Directives and Standards .....	10
EC Directive Compliance .....	10
UL and cUL Compliance .....	11
Conventions .....	12
Acronyms and Abbreviations .....	12

<b>Chapter 2 - Product Overview</b>	<b>15</b>
At a Glance.....	15
Introduction .....	15
What's in this Chapter .....	15
The 17D HP Series Servo Drive Family .....	16
Introducing the 17D HP Drive Family .....	16
Drives Available .....	16
Implementing the Drives .....	16
Applicable Servo Motor Types .....	16
Connection to different mains supply networks .....	17
Electrical Considerations .....	18
17D HP Drive Family Portrait .....	19
Equipment Supplied .....	20
Equipment Necessary .....	20
Equipment Available .....	20
17D HP System Configuration Diagram .....	21
Overview of Usability Features .....	22
Digital Control .....	22
Usability Enhancements .....	23
Restart lock -AS- .....	24
Overview of 17D HP Internal Electronics .....	25
17D HP Internal Electronics Block Diagram .....	25
General Characteristics .....	26
Primary Power .....	26
Bias Power .....	26
EMI Suppression .....	26
Internal Power Section .....	27
DC Link Capacitor Reconditioning .....	27
Integrated Safe Electrical Separation .....	27
LED display .....	27
Overview of System Software .....	29
Setup .....	29
Setting Parameters .....	29
Automatic Card Recognition .....	29
Default Settings .....	29
UniLink Commissioning Software .....	30

---

<b>Chapter 3 - Mounting and Physical Dimensions</b>	<b>31</b>
At a Glance.....	31
What's in this Chapter .....	31
Installation Safety Precautions .....	32
Installation Considerations .....	34
Power Supply Overcurrent Protection .....	34
Earth Connections .....	34
Cable Separation .....	34
Air Flow .....	34
Drive Mounting and Physical Dimensions .....	35
17D HP Height, Width and Depth Dimensions .....	35
17D HP Drive and Mounting Area Dimensions .....	36
Physical Dimensions of accessories .....	37
External Regen Resistor Assembly Dimensions .....	37
Mains Filters Assembly Dimensions .....	38
Mains Choke Assembly Dimensions .....	39
<b>Chapter 4 - Wiring and I/O</b>	<b>41</b>
At a Glance.....	41
Introduction .....	41
What's in this Chapter .....	42
Wiring and I/O Initial Considerations .....	43
Initial Considerations .....	43
Grounding .....	43
Wiring Overview .....	44
Overview of 17D HP Wiring Connections .....	44
Pin assignments for Lexium 17D HP Drive .....	45
Cable Shield Connections .....	46
Connecting Cable Shields to the Front Panel .....	46
Cable Shield Connection Diagram .....	47
Power Wiring .....	48
AC Mains Power Supply Connection .....	48
Bias Supply Connection .....	48
External Regen Resistor Connection .....	49
Regen Circuit Functional Description .....	49

---

Servo Motor (with Brake) Connection .....	50
Servo Motor (with Optional Dynamic Brake Resistors and Contactor) Connection .....	51
Servo Motor Holding-Brake Control Functional Description .....	52
Signal Wiring .....	54
Resolver Connection .....	54
Encoder Input Connection .....	55
Incremental Encoder Emulation .....	56
Incremental- Encoder Output Functional Description .....	56
SSI Encoder Emulation .....	57
SSI Encoder Output Functional Description .....	57
Diagram of master-slave operation .....	58
Incremental encoder emulation .....	58
SSI encoder emulation .....	58
External Incremental encoder connection .....	59
External SSI encoder connection .....	60
Analog I/O Connection .....	61
Analog Inputs .....	61
Servo Motor Rotation Direction .....	61
Analog Outputs .....	62
Fault Relay and Digital I/O Connection .....	63
Digital Inputs and Outputs .....	63
Using Functions Pre-programmed into the Drive .....	64
Serial Communications Connection .....	65
Serial Communications Connection Diagram .....	65
CANopen Interface .....	66
CAN bus cable .....	67
Expansion module AM02CA001V000 .....	68
Position of the connectors .....	68
Fitting the expansion module .....	68
Connection technology .....	69
Connector assignments .....	69
Connection diagram .....	70
Stepper Motor Control Interface Connection .....	71
Stepper-Motor Control Interface Connection Functional Description .....	71
Stepper-Motor Control Interface Connection Diagram .....	71
Stepper-Motor Speed Profile and Signal Diagram .....	72

---

<b>Chapter 5 - System Operation</b>	<b>73</b>
At a Glance.....	73
What's in this Chapter .....	73
Powering Up and Powering Down the System .....	74
Power-on and Power-off Characteristics .....	74
Stop Function .....	75
Emergency Stop strategies .....	76
Wiring example .....	77
Description of the restart lock -AS- .....	78
Advantages of the restart lock .....	78
Functional description .....	79
Block diagram .....	80
Signal diagram (sequence) .....	81
Installation / Commissioning .....	82
Connection diagram .....	83
Application examples .....	84
Procedure for Verifying System Operation .....	86
Overview .....	86
Quick Tuning Procedure .....	87
Parameter settings .....	89
Multi-Axis System .....	89
Front Panel Controls and Indicators .....	90
Keypad Operation .....	90
LED Display .....	91
<b>Chapter 6 - Troubleshooting</b>	<b>93</b>
At a Glance.....	93
What's in this Chapter .....	93
Warning Messages .....	94
Warning Identification and Description .....	94
Error Messages .....	95
Error Identification and Description .....	95
Troubleshooting .....	99
Problems, Possible Causes and Corrective Actions .....	99

<b>Appendix A - Specifications</b>	<b>101</b>
At a Glance.....	101
What's in this Appendix .....	101
Performance Specifications .....	102
Performance Specifications Table .....	102
Environmental and Mechanical Specifications .....	103
Environmental Specifications Table .....	103
Mechanical Specifications Table .....	104
Electrical Specifications .....	105
What's in this Section .....	105
Electrical Specifications - Power .....	106
Line Input Specifications Table .....	106
Bias Input Specifications Table .....	107
Limit supply values of the servodrive MHDA associated with a BPH motor brake .....	107
External Fuse Specifications Table .....	107
Motor Output Specifications Table .....	109
Internal Power Dissipation Specifications Table .....	110
Electrical Specifications - Regen Resistor .....	111
Regen Circuit Specifications .....	111
Electrical Specifications - Signal .....	112
Motor Overtemperature Input Specifications Table .....	112
Resolver Input Specifications Table .....	112
Encoder Input Specifications Table .....	113
Emulated Encoder Output (Incremental Format) Specifications Table .....	113
Encoder Output (Incremental Format) Timing Diagram .....	114
Encoder Output (SSI Format) Specifications Table .....	114
Encoder Input (Slave) Specifications Table .....	115
Discrete Input Specifications Table .....	115
Discrete Output Specifications Table .....	116
Fault Relay Output Specifications Table .....	116
Brake Output Specifications Table .....	116
Analog Input Specifications Table .....	117
Analog Output Specifications Table .....	117
Serial Communications Specifications Table .....	118
Wire Specifications (Recommended) .....	119
Wire Specifications .....	119

---

## **Appendix B - Parts List** **121**

At a Glance.....	121
What's in this Appendix .....	121
Lexium 17D HP Drives .....	122
Drives Available .....	122
Mains choke .....	123
Mains choke .....	123
External 24VDC supply .....	124
External 24VDC supply .....	124
Drive Cables .....	125
Drive to Motor Cables .....	125
RS-232 Serial Communications Cable Part Table .....	125
Encoder Output Cable Parts Table .....	125
Optional External Regen Resistor Assemblies .....	126
Optional Regen Resistor Assembly Part Table .....	126
Optional Mains filters .....	127
Optional Mains filters .....	127
Spare Parts .....	128
Spare Parts Table .....	128

## **Appendix C - Drive-to-Controller Wiring Diagrams** **129**

At a Glance.....	129
What's in this Appendix .....	129
Typical Motion Controller Interface Connections .....	130
Motion Controller Interface Diagram .....	130
Wiring a 17D HP Drive to Premium CAY Motion Modules .....	131
Premium CAY Single Axis Drive Option Diagram .....	131
Premium CAY Multi-Axis Breakout Module Wiring Diagram .....	132
Premium CAY Multi-Axis and Breakout Module Diagram, First of Four Axes .....	133
Wiring a 17D HP Drive to a MOT 201 Motion Module .....	134
MOT 201 Control Wiring Diagram .....	134
MOT 201 Encoder Wiring Diagram : Option 1 .....	135

MOT 201 Encoder Wiring Diagram : Option 2 .....	136
Wiring a 17D HP Drive to Quantum 140 MSx Motion Modules .....	137
Quantum 140 MSx Control and Encoder Wiring Diagram .....	137
Wiring a 17D HP Drive to B885-11x Motion Modules .....	138
B885-11x Control Wiring Diagram .....	138
B885-11x Encoder Wiring Diagram : Option 1 .....	139
B885-11x Encoder Wiring Diagram : Option 2 .....	140
<b>Appendix D - Cable Connection Wiring Diagrams</b>	<b>141</b>
At a Glance.....	141
What's in this Appendix .....	141
Wiring the Motor Power Connector (drive side) .....	142
Motor Power Connector (Drive end) Diagram .....	142
Wiring a Sub-D Connector with Shielding .....	143
Wiring the Sub-D Connector .....	143
Sub-D Connector Diagram .....	144
Wiring the feedback connector of the motors .....	145
Wiring the feedback connector of the BPH motors .....	145
Serial Communication Interface Connection (X6) RS 232 .....	146
Serial Communication Interface Cable Connectors .....	146
<b>Appendix E - Servo Loop Diagrams</b>	<b>147</b>
At a Glance.....	147
What's in this Appendix .....	147
17D HP Current Controller Overview .....	148
17D HP Current Controller Diagram .....	148
17D HP Velocity Controller Loop .....	149
17D HP Velocity Controller Loop Diagram .....	149
17D HP Analog Input Loop Diagrams .....	150
Overview .....	150
17D HP Analog Input Mode 0 Loop Diagram .....	150
17D HP Analog Input Mode 1 Loop Diagram .....	151
17D HP Analog Input Mode 3 Loop Diagram .....	152
17D HP Analog Input Mode 4 Loop Diagram .....	153

---

17D HP Analog Input Mode 5 Loop Diagram .....	154
<b>Appendix F - Expansion Options</b>	<b>155</b>
At a Glance .....	155
What's in this Appendix .....	155
Expansion Card .....	156
Overview .....	156
Fitting expansion card .....	156
I/O Expansion Cards .....	157
24 Vdc Discrete I/O Expansion Card .....	157
IConnector and LED Location Diagram .....	158
Light-Emitting Diodes (LEDs) .....	158
Terminal Assignments .....	159
Controlling Pre-programmed Motion Tasks .....	161
Programming the PLC .....	161
Motion Task Coordination .....	161
Motion Task Application Examples .....	161
Example of a Motion Task Number .....	162
Connection Diagram .....	163
<b>Appendix G - External Regen Resistor Sizing</b>	<b>165</b>
At a Glance .....	165
What's in this Appendix .....	165
Overview .....	166
Determining When Energy Is Absorbed .....	166
Determining External Regen Resistor Size .....	167
Power Dissipation Calculation Procedure .....	167
Drive Energy Absorption Capability .....	168
Example Regen Resistor Power Dissipation Calculation .....	169
Example Motor and Drive Specifications .....	169
Example Step 1 .....	170
Example Step 2 .....	171
Example Step 3 .....	171
Example Step 4 .....	172
Example Step 5 .....	172
Example Step 6 .....	172
Example Step 7 .....	172
Example Step 8 .....	173



---

# Introduction



---

## At a Glance

**Document Scope** This user guide contains complete installation, wiring interconnection, power application, test and maintenance information on the Lexium 17D HP series servo drive.

**What's in this Chapter** This chapter provides general information about this user guide and contains the following topics:

Topic	Page
About this user guide	2
Related system components	4
Related documentation	5
Hazards, warnings, and guidelines	6
Standards and compliances	10
Conventions	12

---

## About this User Guide

---

### Who Should Use this User Guide

This user guide is written for any qualified person at your site who is responsible for installing (mounting and interconnecting), operating, testing and maintaining your Lexium 17D HP servo drive and the servo system equipment with which it interfaces. In addition, the following precautions are advised:

- Transportation of the servo drive to, or from, an installation site should only be performed by personnel knowledgeable in handling electrostatically sensitive components.
- Commissioning of the equipment should only be performed by personnel having extensive knowledge of, and experience with, electrical and servo drive technologies.

You are expected to have some overall understanding of what your 17D HP servo drive does and how it will function in a high-performance, single-axis motion control system. Accordingly, be sure you read and understand the general information, detailed descriptions and associated procedures presented in this manual, as well as those provided in other relevant manuals, before installing your 17D HP. (See *Related System Components* later in this chapter.)

If you have questions, please consult your Schneider Electric customer representative.

---

### How this User Guide Is Organized

This manual is organized as follows.

Chapter/Appendix	Description
Chapter 1 <i>About this User Guide</i>	An introduction to this manual — who should use this manual, how this manual is organized, related publications, hazards and warnings.
Chapter 2 <i>Lexium 17D HP Product Overview</i>	General descriptions of the 17D HP servo drives, descriptions of components that are supplied by Schneider in a typical 17D HP system, and a block diagram for internal electronics.
Chapter 3 <i>Mounting and Physical Dimensions</i>	Physical dimensions and information for mounting the servo drive, Regen resistor and optional Mains filter.

---

*Continued on next page*

---

## About this User Guide, continued

---

### How this Manual Is Organized, continued

<b>Chapter/Appendix</b>	<b>Description</b>
Chapter 4 <i>Wiring and I/O</i>	Wiring diagrams for the power connections and wiring diagrams and descriptions for all signal wiring connections — encoder, resolver, analog I/O, discrete I/O, and serial communications cable.
Chapter 5 <i>System Initialization, Commissioning and Operation</i>	Detailed procedures and associated descriptions on how to initialize, commission and operate a typical 17D HP system.
Chapter 6 <i>Troubleshooting</i>	Description of faults, probable causes and recommended corrective actions.
Appendix A <i>Specifications</i>	Specifications for the servo drives, including general, electrical, signal, and power specifications.
Appendix B <i>Parts List</i>	Part numbers related to the 17D HP servo drive system.
Appendix C <i>Drive to Controller Wiring Diagrams</i>	Wiring diagrams that show signal wiring between a 17D HP servo drive and MOT 201, Quantum MSx, B885-11x, and Premium CAY motion modules.
Appendix D <i>Cable Connection Wiring Diagrams</i>	Procedures and associated diagrams that show how to wire Sub-D and power cable connectors as well as the serial communication cable used with the drive.
Appendix E <i>Servo Loop Diagrams</i>	Illustrations of the 17D HP servo drive and single-axis motion module servo loops.
Appendix F <i>Expansion Options</i>	Description and procedure for using the expansion cards with the drive.
Appendix G <i>External Regen Resistor Sizing</i>	Description and procedure for determining the power dissipation requirement for the external Regen resistor.

---

---

## Related System Components

---

### **Single-Axis Motion Control System**

The 17D HP servo drive is typically only one component in a larger, single-axis motion control system. A single axis comprises one motion module, one servo drive, and one motor.

Compatible Schneider motion modules include:

- Quantum 140 MSx series motion modules
  - Compact MOT 201 motion modules
  - B885-11x series motion modules
  - Premium CAY motion modules
- 

### **UniLink Commissioning Software for 17D HP**

To configure your single-axis system, you will be using the UniLink axis commissioning software, which Schneider supplies.

UniLink allows you to configure your 17D HP servo drive axis and tune the motor quickly and easily. With its graphical user interface and oscilloscope tuning features, UniLink provides an easy point-and-click method for configuring motion setup parameters. UniLink minimizes or eliminates cumbersome programming tasks.

For complete information on UniLink, please see the UniLink online help.

---

---

## Related Documentation

---

### Documents

Related documentation that covers all these system components is illustrated below.

You will need these:

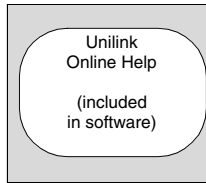

Depending on which motion module you have, you will also need one of these:

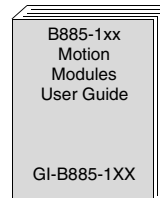
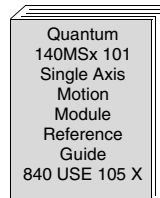
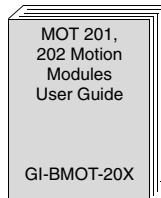

If you have a Premium motion module, you will also need this:

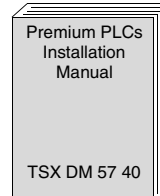
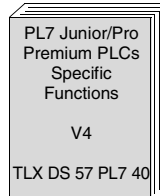

If you have a BPH motor, you will also need this:



\* included in AM0 CSW 001V350 (CDROM)

---

## Hazards, Warnings and Guidelines

---

### Hazards and Warnings

Read the following precautions very carefully to ensure the safety of personnel at your site. Failure to comply will result in death, serious injury or equipment damage.



#### **DANGER!**

#### **ELECTRIC SHOCK HAZARDS**

- During operation, keep all covers and cabinet doors closed.
- Do not open the servo drives; depending on degree of enclosure protection, the servo drives may have exposed components.
- Control and power connections on the drive may be energized even if the motor is not rotating.
- Never attempt to disconnect the electrical connections to the servo drive with power applied. Failure to comply may result in arcing at the contacts.
- Wait at least five minutes after disconnecting the servo drive from the mains supply voltage before touching energized sections of the equipment (for example, contacts) or disconnecting electrical connections. Capacitors can still have dangerous voltages present up to five minutes after switching off the supply voltages. To ensure safety, measure the voltage in the DC Link circuit and wait until it has fallen below 40V before proceeding.
- Check to ensure all energized connecting elements are protected from accidental contact. Lethal voltages up to 900V can be present. Never disconnect any electrical connections to the servo drive with power applied; capacitors can retain residual and dangerous voltage levels for up to five minutes after switching off the supply power.

**Failure to follow any one of these instructions will result in death, serious injury or equipment damage.**

---

*Continued on next page*

---

## Hazards, Warnings and Guidelines, continued

---



### **WARNING!**

#### **THERMAL HAZARD**

During operation, the front panel of the servo drive, which is used as a heat sink, can become hot and may reach temperatures above 80°C. Check (measure) the heat sink temperature and wait until it has cooled below 40°C before touching it.

**Failure to observe this precaution can result in severe injury.**

---



### **WARNING!**

#### **OVERCURRENT, OVERLOAD AND OVERHEATING PROTECTION**

Separate motor overcurrent, overload and overheating protection is required to be provided in accordance with the Canadian Electrical Code, Part 1 and the National Electrical Code.

**Failure to observe this precaution can result in severe injury.**

---

*Continued on next page*

---

## Hazards, Warnings and Guidelines, continued

---



### CAUTION!

#### SAFETY INTERLOCKS

Schneider recommends the installation of a safety interlock with separate contacts for each motor. Such a system should be hard wired with over-travel limit switches and a suitable emergency stop switch. Any interruption of this circuit or fault indication should:

- Open the motor contacts
- Shunt dynamic braking resistors across each motor, if they are present.

**Failure to observe this precaution can result in equipment damage.**

---



### CAUTION!

#### ELECTROSTATIC COMPONENTS

The servo drives contain electrostatically sensitive components that may be damaged by improper handling. Appropriately discharge yourself before touching the servo drive and avoid contact with highly insulating materials (artificial fabrics, plastic film, and so on). Place the servo drive on a conductive surface.

**Failure to observe this precaution can result in equipment damage.**

---

*Continued on next page*

---

## Hazards, Warnings and Guidelines, continued

---

### **Additional Safety Guidelines**

Read this documentation and adhere to the safety guidelines contained herein before engaging in any activities involving the servo drives.

- Ensure that all wiring is in accordance with the National Electrical Code (NEC) or its national equivalent (CSA, CENELEC, etc.), as well as in accordance with all prevailing local codes.
- Exercise extreme caution when using instruments such as oscilloscopes, chart recorders, or volt–ohm meters with equipment connected to line power.
- Handle the servo drives as prescribed herein. Incorrect handling can result in personal injury or equipment damage.
- Adhere to the technical information on connection requirements identified on the nameplate and specified in the documentation.
- The servo drives may only be operated in a closed cabinet or enclosure.
- **Nevertheless, operating conditions must be always respected (as defined in Appendix A):**
  - **operating temperature range**
  - **pollution degree 2 as defined in EN 50178**
  - **assembly.**

---

### **Qualified Personnel**

Only properly qualified personnel having extensive knowledge in electrical and servo drive technologies should install, commission and/or maintain the Lexium 17D HP servo drives.

---

---

## Standards and Compliances

---

### **European Directives and Standards**

The Lexium 17D HP servo drives are incorporated into an electrical plant and into machinery for industrial use.

When the servo drives are built into machines or a plant, do not operate the servo drive until the machine or plant fulfills the requirements of these European Standards:

- EC Directive on Machines 89/392/EEC
- EC Directive on EMC (89/336/EEC)
- EN 60204
- EN 292

In connection with the Low Voltage Directive 73/23/EEC, the associated standards of the EN 50178 series in conjunction with EN 60439-1, EN 60146 and EN 60204 are applied to the servo drives.

The manufacturer of the machine or plant is responsible for meeting the requirements of the EMC regulations.

---

### **EC Directive Compliance**

Compliance with the EC Directive on EMC 89/336/EEC and the Low Voltage Directive 73/23/EEC is mandatory for all servo drives used within the European Community.

The Lexium 17D HP servo drives were tested by an authorized testing laboratory and determined to be in compliance with the directives identified above.

---

*Continued on next page*

---

## Standards and Compliances, continued

---

### **UL and cUL Compliance**

UL Listed (cUL Certified) servo drives (Underwriters Laboratories Inc.) comply with the relevant American and Canadian standards (in this case, UL 840 and UL 508C).

This standard describes the minimum requirements for electrically operated power conversion equipment (such as frequency converters and servo drives) and is intended to eliminate the risk of injury to personnel from electric shock or damage to equipment from fire. Conformance with the United States and Canadian standard is determined by an independent UL (cUL) fire inspector through the type testing and regular checkups.

#### **UL 508C**

UL 508C describes the minimum requirements for electrically operated power conversion equipment (such as frequency converters and servo drives) and is intended to eliminate the risk of fire caused by that equipment.

#### **UL 840**

UL 840 describes air and insulation creepage spacings for electrical equipment and printed circuit boards.

---

---

## Conventions

---

### Acronyms and Abbreviations

The acronyms and abbreviations used in this manual are identified and defined in the table below.

<b>Acronym or Abbreviation</b>	<b>Description</b>
CE	European Community (EC)
CLK	Clock signal
COM	Serial communication interface for a PC-AT
cUL	Underwriters Laboratory (Canada)
DIN	German Institute for Norming
Disk	Magnetic storage (diskette, hard disk)
EEPROM	Electrically erasable programmable read only memory
EMC	Electromagnetic compatibility
EMI	Electromagnetic Interference
EN	European norm
ESD	Electrostatic discharge
IEC	International Electrotechnical Commission
IGBT	Insulated Gate Bipolar Transistor
ISO	International Standardization Organization
LED	Light Emitting Diode
MB	Megabyte
MS-DOS	Microsoft Disk Operating System for PC-AT
PC-AT	Personal computer in AT configuration
PELV	Protected extra low voltage
PWM	Pulse-width modulation
RAM	Random Access Memory (volatile)
Regen	Regen resistor
RBext	External Regen resistor
RFI	Radio Frequency Interference

---

*Continued on next page*

---

## Conventions, continued

### Acronyms and Abbreviations, continued

<b>Acronym or Abbreviation</b>	<b>Description</b>
PLC	Programmable Logic Controller
SRAM	Static RAM
SSI	Synchronous Serial Interface
UL	Underwriters Laboratory
Vac	Voltage, Alternating Current
Vdc	Voltage, Direct Current

---

---

# Product Overview

# 2

---

## At a Glance

### Introduction

This chapter contains a product overview of the Lexium 17D HP series servo drives and includes:

- Available drive models and related system components
- Feedback and performance information
- Power and signal electronics
- Software and axis configuration

---

### What's in this Chapter

This chapter contains the following topics:

Topic	Page
The 17D HP series servo drive family	16
Overview of usability features	22
Overview of 17D HP internal electronics	25
Overview of system software	29

---

## The 17D HP Series Servo Drive Family

---

### **Introducing the 17D HP Drive Family**

Each member of the Lexium 17D HP series family is comprised of a three-phase brushless servo amplifier, power supply and high-performance digital controller all housed in a single enclosure.

---

### **Drives Available**

The 17D HP drives are available in two models which are correlated to different output current levels as identified in the following table.

<b>Output Current Intermittent (Peak)</b>	<b>17D HP Drive</b>
112A	MHDA1112*00
198A	MHDA1198*00
Note: A00 means that restart lock -AS- is included.	

---

### **Implementing the Drives**

The Lexium 17D HP servo drives are intended for incorporation into electrical equipment or machinery and can only be commissioned as integral components of those types of devices.

---

### **Applicable Servo Motor Types**

The Lexium 17D HP servo drives are intended to drive Lexium BPH series brushless servo motors.

---

*Continued on next page*

# The 17D HP Series Servo Drive Family, continued

## Connection to different mains supply networks



On this page you'll find all possible connection variations to different mains supply networks.

### WARNING !

An isolating transformer is always required for 400...480V mains networks without earth(ground) and for networks with asymmetrical earth(ground).

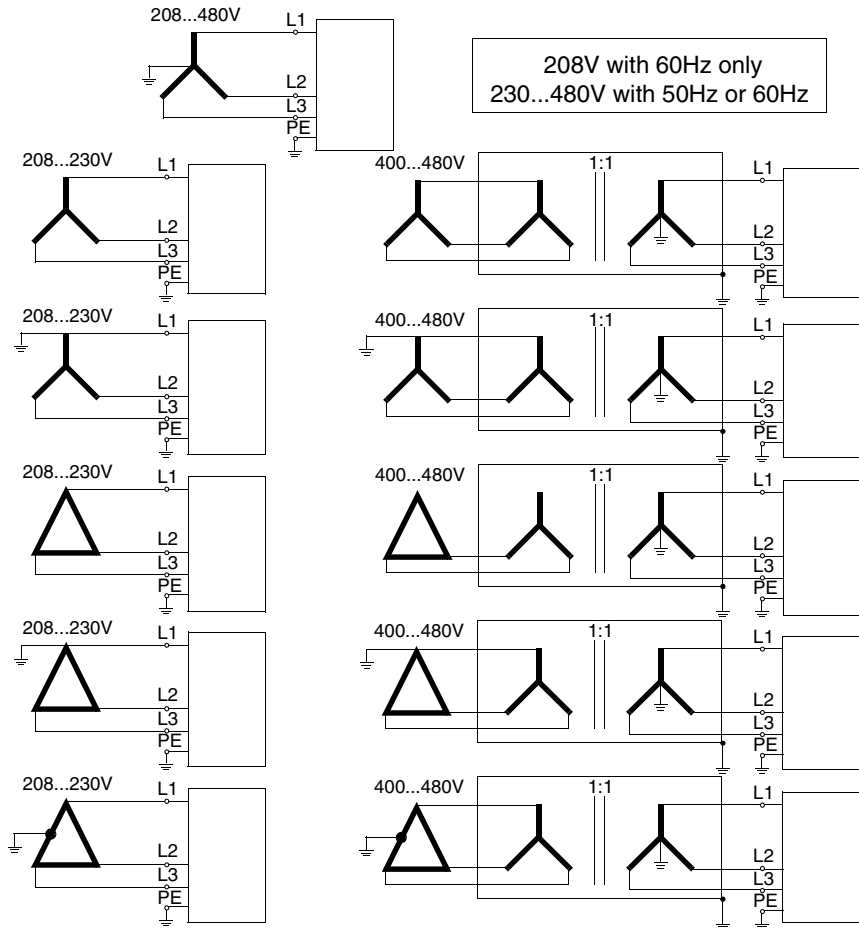

Continued on next page

---

## The 17D HP Series Servo Drive Family, continued

---

### Electrical Considerations

The Lexium 17D HP family of servo amplifiers is to be used on earthed three-phase industrial mains supply networks (TN-system, TT-system with earthed neutral point, not more than 5000 rms symmetrical amperes).

Periodic overvoltages between outer conductor (L1, L2, L3) and housing of the servo amplifier may not exceed 1000V (peak value). Transient overvoltages (< 50 $\mu$ s) between the outer conductors may not exceed 1000V. Transient overvoltages (< 50 $\mu$ s) between outer conductors and housing may not exceed 2000V.

The Lexium 17D HP drives are incompatible with the IT system because interference suppression filters are internal and connected to earth. If the user wants to connect Lexium drives to an IT system, he may:

- use an insulation star transformer in order to re-create a local TT or TN system. This way allows the rest of the wiring to stay an IT system (only warning in case of the first fault.)
- use a special Residual Current Circuit Breaker (RCCB) that is able to work with dc and high peak currents. This device detects unbalance of phases with regard to earth.

Warning: When the first fault occurs, the RCCB has to switch off quickly power of the drives. Set of the residual current value must be carefully done and must be started with the lowest available value (for example: 30mA.)

Following equipment of Merlin Gerin can be used:

- Vigirex, model RH328AF (Reference: 50055)
- One of these magnetic cores:
  - model TA, 30mm in internal diameter (Reference: 50437)
  - model PA, 50mm in internal diameter (Reference: 50438)
  - model IA, 80mm in internal diameter (Reference: 50439)

If the servo amplifiers are used in residential areas, or in business or commercial premises, then additional filter measures must be implemented by the user.

The Lexium 17D HP family of servo amplifiers is **only** intended to drive specific brushless synchronous servomotors from the Lexium BPH series, with closed-loop control of torque, speed and/or position. **The dielectric withstand voltage of the motors must be at least as high as the DC-link voltage of the servo amplifier.**

Use only copper wire. Wire size may be determined from EN 60204 (or table 310-16 of the NEC 60°C or 75°C column for AWG size).

We only guarantee the conformance of the servo amplifiers with the standards for industrial areas, if the components (motors, cables, amplifiers etc) are delivered by Schneider Automation.

---

*Continued on next page*

---

## The 17D HP Series Servo Drive Family, continued

---

### 17D HP Drive Family Portrait

The following photograph shows a representative member of the 17D HP drive family. The complete family consists of two models. Models MHDA1112•00, MHDA1198•00, have dimensionally identical physical housings. (See Chapter 3 for detailed dimensional information.)



A00 means that restart lock -AS- is included.

---

*Continued on next page*

---

## The 17D HP Series Servo Drive Family, continued

---

### Equipment Supplied

Each 17D HP servo drive includes the following hardware.

- Mating connectors X3, X4 and X10
- Read me first



**Note:** The mating Sub-D connectors are supplied with the appropriate cable.

---

### Equipment Necessary

- Mains choke
- 

### Equipment Available

The following items are optionally available to you from Schneider for use with the 17D HP servo drives:

- Lexium BPH series brushless servo motors
- Servo motor power and feedback cables



**Note:** Feedback cables are available in lengths from 5...75 m and are supplied by Schneider with the connector for the servo motor attached to the cable and with the connector for the drive unassembled and unattached to the cable. The 10 m length feedback cable is supplied (from stock) by Schneider with connectors attached to each end of the cable.

- Optional External Regen resistor
  - Serial communications cable (between drive and PC)
  - Pre-configured cables for various Telemecanique and Modicon motion controllers.
  - Mains filter (class A)
  - Optional expansion cards.
  - Optional accessories and communication cards (SERCOS, MODBUS+, FIPIO, PROFIBUS DP).
- 

*Continued on next page*

## The 17D HP Series Servo Drive Family, continued

### 17D HP System Configuration Diagram

The following illustration shows a typical 17D HP system configuration.

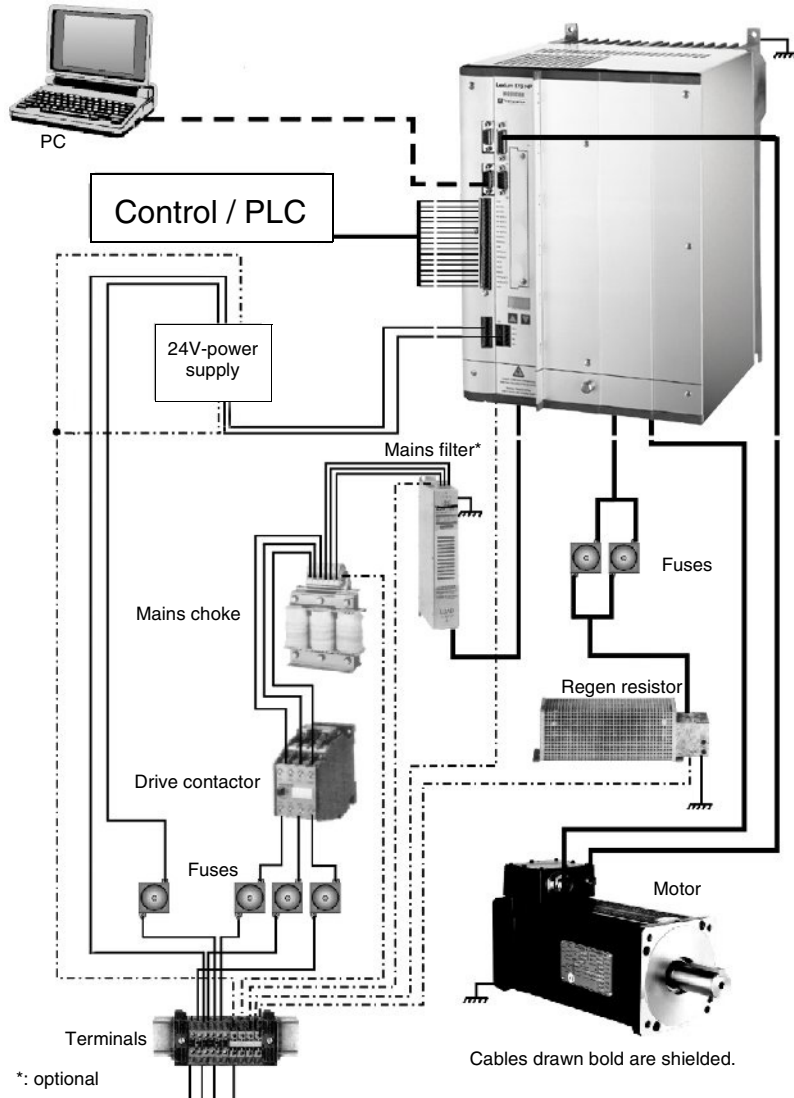

---

## Overview of Usability Features

---

### Digital Control

The 17D HP drive provides complete digital control of a brushless servo system. This includes:

- A digital field-oriented current controller operating at an update rate of 62.5  $\mu$ s
- A fully programmable digital PI-type speed controller operating at an update rate of 250  $\mu$ s
- If required by user application, an integrated, digital, position controller with configurable trajectory generation operating at an update rate of 250  $\mu$ s is also available. Up to 180 independent motion tasks can be configured and stored in the drive depending upon the application requirements.
- An integral step/direction input is provided for use with an external indexer which allows the 17D HP drive and the applicable BPH motor to be used as a stepper motor/drive replacement.
- Full digital evaluation of motor position feedback (primary feedback) from either a standard two-pole resolver or a high precision Sin-Cos type encoder (hiperface).
- Full digital emulation of either a standard incremental encoder or a SSI encoder is also available from position information derived from the primary feedback device. The drive may also be configured as a slave to follow a master incremental encoder with a programmable gear ratio.

---

*Continued on next page*

---

## Overview of Usability Features, continued

---

### **Usability Enhancements**

The following features are incorporated into the 17D HP drive to facilitate the set-up and operation of the servo system:

- Two analog +/-10 V inputs can be programmed for a multitude of functions depending upon the application. Both inputs incorporate automatic offset compensation, dead-band limitation and slew-rate limitation.
  - Two +/-10 V analog monitor outputs can be programmed to support a multitude of internal drive control loop variables via the analog voltage output levels.
  - Four fully programmable 24 V discrete inputs; two of which are typically defined as hardware limit switches.
  - Two fully programmable 24 V outputs and a separate 24 V brake output capable of driving a maximum of 3 Amps.
  - An integrated and fully isolated RS-232 connection for communication with a PC; used to set configuration parameters and tune the system with the Unilink configuration software.
  - A separate 24V bias supply input which may be connected through a UPS to preserve system data in the event of an interruption in the AC mains supply. Interference suppression filter (to class A) is integrated.
  - Integrated CANopen (default 500 kBauds).
  - Restart lock -AS-
-

---

## Overview of Usability Features, continued

---

**Restart lock -AS-** The restart lock -AS- is **exclusively** intended to provide safety for personnel, by preventing the restart of a system. To achieve this personnel safety, the wiring of the safety circuits must meet the safety requirements of EN60204, EN292 and EN 954-1.

The -AS- restart lock must **only** be activated,

- When the motor is no longer rotating (setpoint = 0V, speed = 0rpm, enable = 0V).  
Drives with a suspended load must have an additional safe mechanical blocking (e.g. by a motor-holding brake).
- When the monitoring contacts (KSO1/2 and Fault RA/RB for all servo amplifiers are wired into the control signal loop (to recognize a cable break).

The -AS- restart lock may **only** be controlled by a PLC if the control of the internal safety relay is arranged for redundant monitoring.

The -AS- restart lock must **not** be used if the drive is to be made inactive for the following reasons

- Cleaning, maintenance and repair operations
  - Long inoperative periods  
In such cases, the entire system should be disconnected from the supply by the personnel, and secured (main switch).
  - Emergency-stop situations.  
In an emergency-stop situation, the main contactor is switched off (by the emergency-stop button or the Fault RA/RB contact in the safety circuit).
-

## Overview of 17D HP Internal Electronics

### 17D HP Internal Electronics Block Diagram

The following block diagram illustrates the 17D HP internal electronics and depicts internal interfaces for power, signal I/O, and communication.

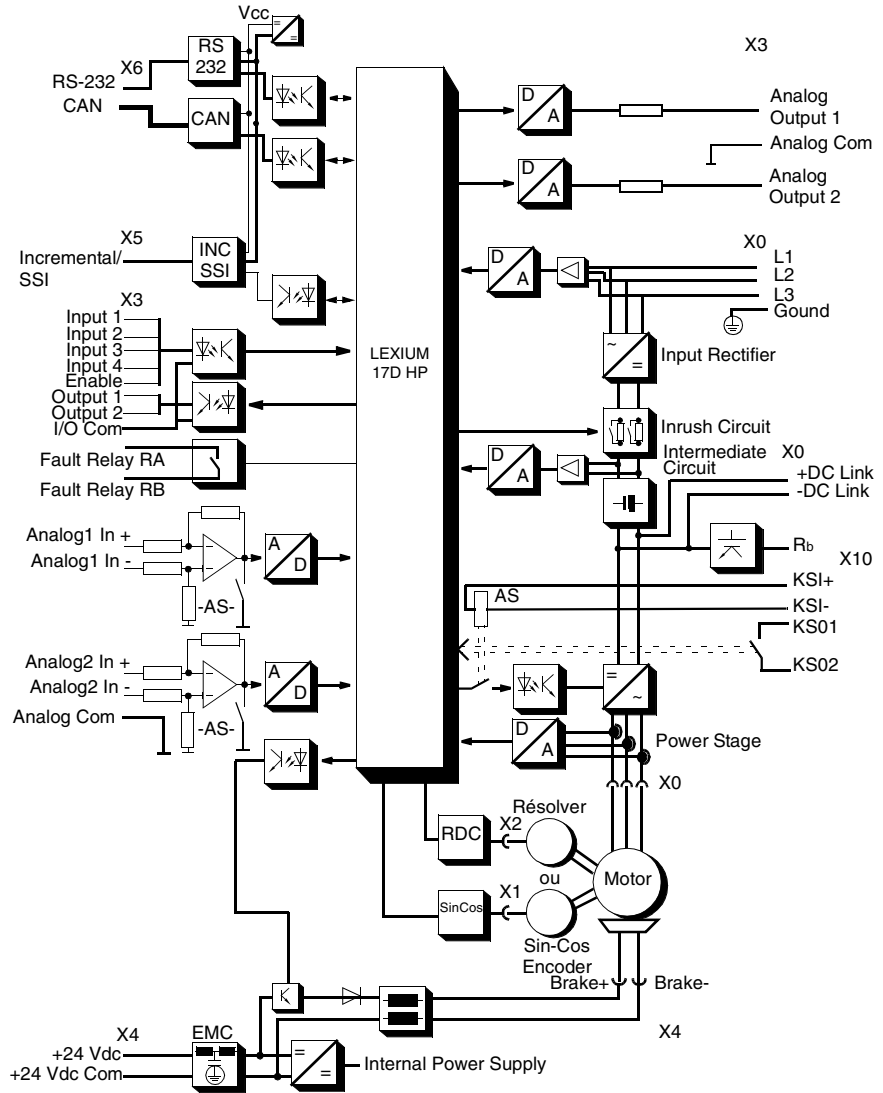

*Continued on next page*

---

## Overview of 17D HP Internal Electronics, continued

---

### General Characteristics

The Lexium 17D HP servo drives are available in two peak output current ratings (112A, 198A). Drives operate with an input voltage which may range from 208V - 10% 60Hz, 230V -10% 50Hz through 480V +10% 50-60Hz, 3 phase system.

Each drive provides:

- Direct shield connection points
  - Two analog setpoint inputs
  - Integrated and electrically isolated RS-232 communications
- 

### Primary Power

External Mains choke is required and **mandatory**. Fusing (fuse cut-out) is provided by the user. A single phase input supply may be used for commissioning and set-up.

---

### Bias Power

The 17D HP drive requires 24 Vdc bias power from an external, **electrically isolated supply (SELV)**.

---

### EMI Suppression

EMI suppression for the 17D HP drives is provided by filter only on the 24 Vdc bias supply (Class A) input.

---

*Continued on next page*

---

## Overview of 17D HP Internal Electronics, continued

---

### Internal Power Section

The Internal power section of the 17D HP drive includes the following:

- Power input: A rectifier bridge directly connected to the three-phase earthed supply system and inrush current limiting circuit.
  - Motor power output: PWM current-controlled voltage source IGBT-inverter with isolated current measurement
  - Regen circuit: Dynamic distribution of Regen power between several drives on the same DC Link circuit. External Regen resistors are available as required by your application.
  - DC Link voltage: 300...700 V dc, nominal (900 Vdc, intermittent) and can be operated in parallel.
- 

### DC Link Capacitor Reconditioning

If the servo drive has been stored for longer than one year, then the DC Link capacitors will have to be reconditioned as follows:

Step	Action
1	Ensure that all electrical connections to the drive are disconnected.
2	Provide 230 Vac, single-phase power to connector X0 (terminals L1 / L2) on the servo drive for about 30 minutes to recondition the capacitors.

---

### Integrated Safe Electrical Separation

The 17D HP drive ensures safe electrical separation (in accordance with EN 50178) between the power input/motor connections and the signal electronics through the use of appropriate insulation-creepage distances and electrical isolation. The drive also provides soft-start characteristics, overvoltage and overtemperature detection, short-circuit protection and input phase-failure monitoring. When using BPH series servo motors in conjunction with Schneider's pre-assembled cables, the drive also monitors the servo motor for overtemperature.

---

### LED display

A three-character display on the front of the 17D HP drive indicates drive status after the 24 Vdc bias supply is turned on. If applicable during operation, error and/or warning codes are displayed.

---

---

---

---

## Overview of System Software

---

### **Setup**

Configuration software is used for setting up and storing the operating parameters for the Lexium 17D HP series drives. The drive is commissioned with the assistance of the UniLink software and, during this process, the drive can be controlled directly through this software.

---

### **Setting Parameters**

You must adapt the servo drives to the requirements of your installation. This is usually accomplished by connecting a PC (programming unit) to the drive's RS-232 serial interface then running the Schneider-supplied UniLink configuration software.

The UniLink software and the associated documentation are provided on a CD-ROM. Use the UniLink software to alter parameters; you can instantly observe the effect on the drive when there is a continuous (online) connection to the drive. In addition, actual values are simultaneously received from the drive and displayed on the PC monitor.

During the configuration process, the Unilink software will show the BPH motors that are correctly matched to the current rating of the drive being configured.

---

### **Automatic Card Recognition**

Any interface modules (expansion cards) that may be built into the drive or that you install are automatically recognized by the drive's internal firmware. Any additional parameters required for position control or motion-block definition are made available automatically in the UniLink configuration software.

---

### **Default Settings**

Motor-specific default settings for all the reasonable combinations of drive and servo motor are incorporated into the drive's firmware. In most applications, you will be able to use these default values to get your drive running without any problems. (Refer to the UniLink online help for additional information on default values.)

---

---

## Overview of System Software, continued

---

### UniLink Commissioning Software

The minimum PC system requirements needed for the UniLink commissioning software are specified in the following table:

Item	Minimum Requirement
Operating System	Windows 95 Windows 98 Windows 2000 Windows ME Windows NT 4.0
Hardware:	
Processor	486 or higher
Graphics adapter	VGA
RAM	8 Mbytes
Hard drive space	5 Mbytes available
Communications	One RS-232 Serial Port

---

# Mounting and Physical Dimensions

# 3

---

## At a Glance

### What's in this Chapter

This chapter provides information on the mounting requirements for, and physical dimensions of, the Lexium 17D HP series servo drives and includes the following topics:

Topic	Page
Installation safety precautions	32
Installation considerations	34
Drive mounting and physical dimensions	35
Physical Dimensions of accessories	37

---

---

## Installation Safety Precautions

---



### **CAUTION!**

#### **MECHANICAL STRESS**

Protect the drive from physical impact during transport and handling. In particular, do not deform any exterior surfaces; doing so may damage internal components or alter critical insulation distances.

**Failure to observe this precaution can result in injury or equipment damage.**

---



### **CAUTION!**

#### **ELECTRICAL STRESS**

At the installation site, ensure the maximum permissible rated voltage at the Mains and bias input connectors on the drive are not exceeded. (See EN 60204-1, Section 4.3.1.) Excessive voltages on these terminals can result in destruction of the Regen circuit and/or the drive's electronics.

**Failure to observe this precaution can result in injury or equipment damage.**

---



### **CAUTION!**

#### **ELECTRICAL CONNECTIONS**

Never disconnect the electrical connections to the servo drive while power is applied.

**Failure to observe this precaution can result in injury or equipment damage.**

---

*Continued on next page*

---

## Installation Safety Precautions, continued

---



### **CAUTION!**

#### **CONTAMINATION AND THERMAL HAZARD**

Ensure the 17D HP drive is mounted within an appropriately vented and closed switchgear cabinet that is free of conductive and corrosive contaminants. Ensure the ventilation clearances above and below the drive conform to requirements. (Refer to Chapter 3 for additional information.)

**Failure to observe this precaution can result in injury or equipment damage.**

---



### **DANGER!**

#### **ELECTRIC SHOCK HAZARD**

Residual voltages on the DC link capacitors can remain at dangerous levels for up to five minutes after switching off the mains supply voltage. Therefore, measure the voltage on the DC Link (+DC/-DC) and wait until the voltage has fallen below 40 V.

Control and power connections can still be energized, even when the motor is not rotating.

**Failure to observe these instructions will result in death or serious injury.**

---

---

## Installation Considerations

---

### **Power Supply Overcurrent Protection**

You are responsible for providing overcurrent protection (via circuit breakers and/or fuses) for the Vac mains supply and the 24 Vdc bias supply that are connected to the drive.

---

### **Earth Connections**

Ensure the drive and associated servo motor are properly connected to earth.

---

### **Cable Separation**

Route power and control (signal) cables separately. Schneider recommends a separation of at least 20 cm. This degree of separation improves the performance of the system. If a servo motor power cable includes wires for brake control, those wires have a separate shield which must be connected to earth at both ends of the cable.

---

### **Air Flow**

Ensure that there is an adequate flow of cool, filtered air into the bottom of the switchgear cabinet containing the drive.

---

---

## Drive Mounting and Physical Dimensions

---

### 17D HP Height, Width and Depth Dimensions

The following diagram shows height, width and depth dimensions for the 17D HP drive.

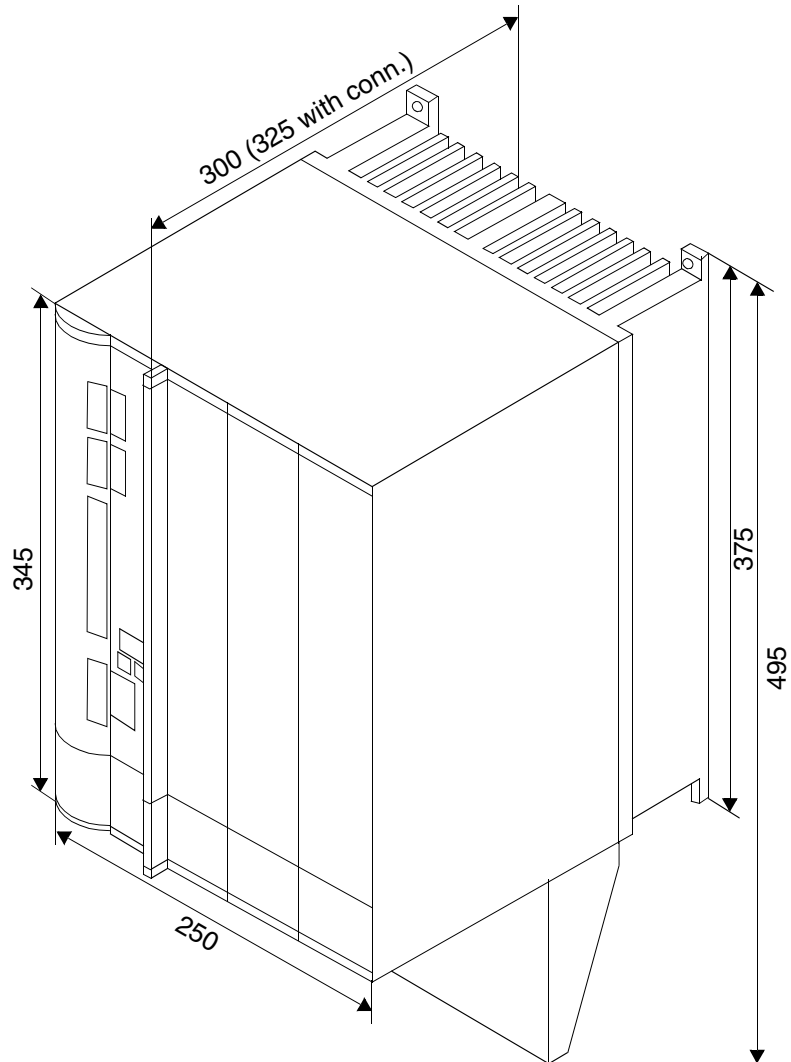

---

*Continued on next page*

## Drive Mounting and Physical Dimensions, continued

### 17D HP Drive and Mounting Area Dimensions

The following diagram shows depth dimensions and mounting area requirements for the 17D HP drive.

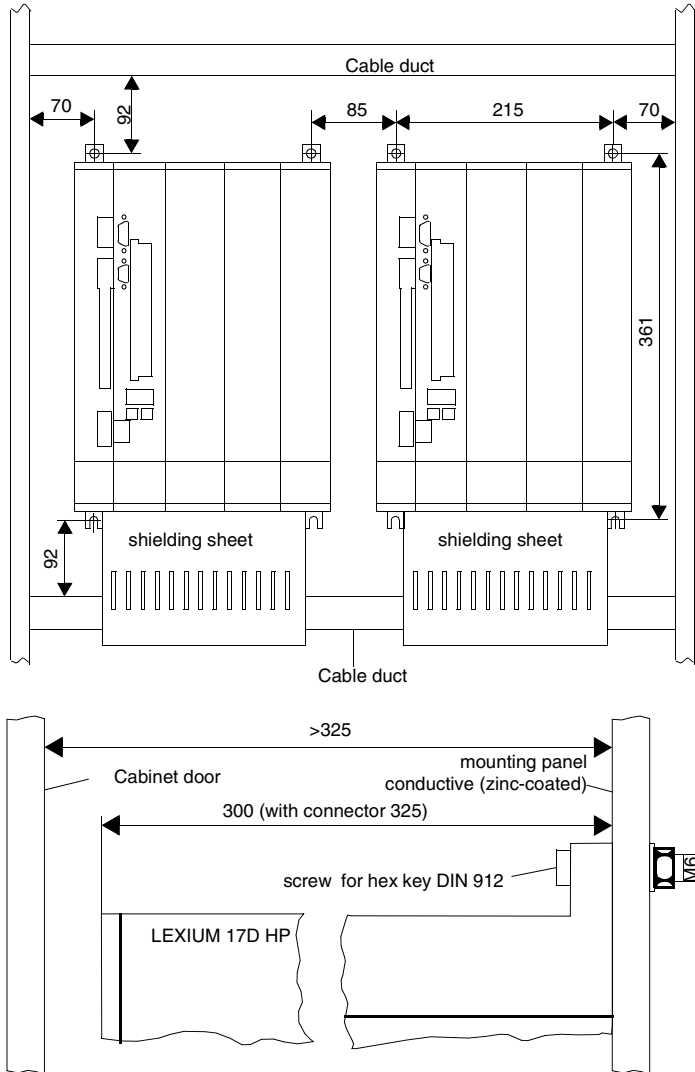

## Physical Dimensions of accessories

### External Regen Resistor Assembly Dimensions

The following diagram shows the dimensions for all two external Regen resistor assemblies.

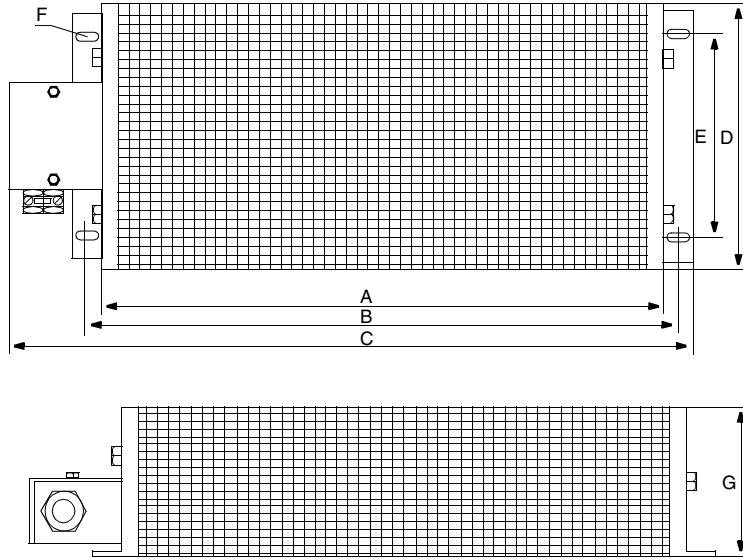

Regen Resistor Assembly Part Number	R	Power	A	B	C	D	E	F	G	Weight
	$\Omega$	W	mm	mm	mm	mm	mm	mm	mm	kg
AM0RFE002V086	15	860	300	326	386	92	64	6,5X12	120	3,5
AM0RFE002V160	10	1600	500	526	570	182	150	5,5X8	130	8,0

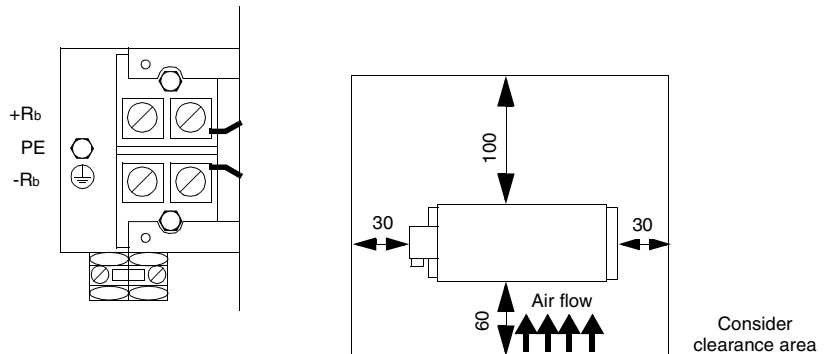

## Physical Dimensions of accessories, continued

### Mains Filters Assembly Dimensions

The following diagram shows the dimensions for the Mains filters assembly.

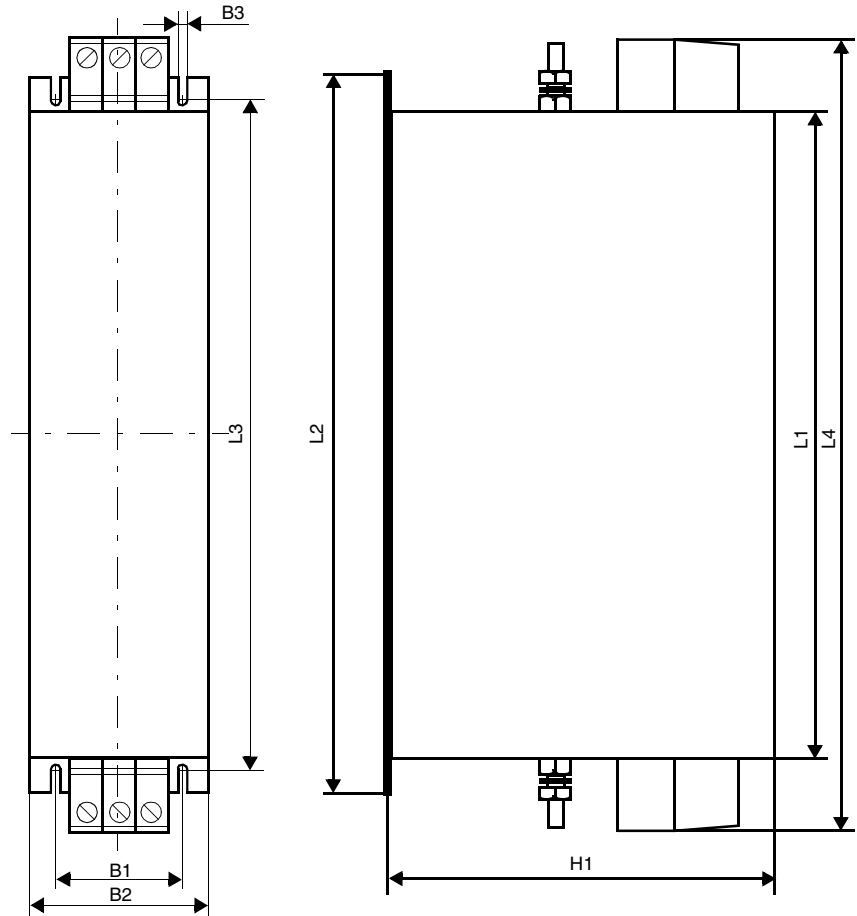

	Nom. current	L1	L2	L3	L4	B1	B2	B3	H1	Terminals	Bolts
Type	A	mm	mm	mm	mm	mm	mm	mm	mm	mm <sup>2</sup>	mm
AMOEMC118	42	305	335	320	355	35	60	7	150	10	5
AMOEMC212	75	300	330	314	380	55	80	7	185	25	6

## Physical Dimensions of accessories, continued

### Mains Choke Assembly Dimensions

The following diagram shows the dimensions for the Mains choke assembly.

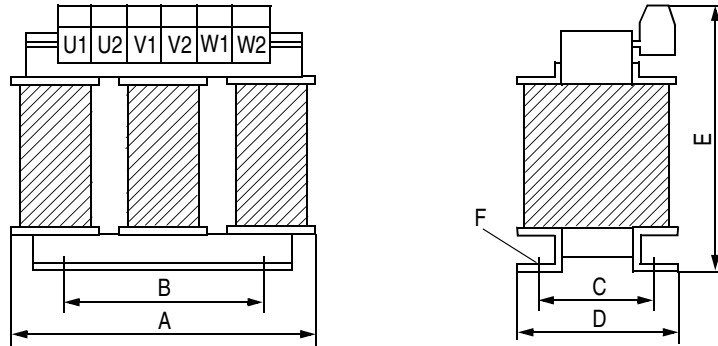

Type	Phase	Dimensions in mm						Weight	Current
		A	B	C	D	E	F	kg	A
AMOCHK170	3	190	170	58	110	255	Ø8	9	60
AMOCHK212	3	190	170	68	120	255	Ø8	10	75

---

---

# Wiring and I/O

# 4

---

## At a Glance

### Introduction

This chapter describes and illustrates all power wiring connections, all signal wiring connections, and I/O wiring connections on the 17D HP drive. Power and signal wiring connections are:

- **AC mains power** through a terminal block connector, x0
- **Bias power** through six-position, plug-in, terminal block connector, x4
- **Servo motor power** through a terminal block connector, x0
- **Regen power resistor** through a terminal block connector, x0
- **Resolver feedback input** through a nine-pin, plug-in, Sub-D connector, x2
- **Encoder feedback input** through a 15-pin, plug-in, Sub-D connector, x1
- **Auxiliary encoder/command interface** through a nine-pin, plug-in, Sub-D connector, x5
- **Master-Slave drive interface** through a nine-pin, plug-in, Sub-D connector, x5
- **Analog/digital I/O** through an 18-position, plug-in terminal block connector, x3
- **Serial communications interface** through a nine-pin, plug-in, Sub-D connector, x6
- **Stepper-motor control interface** through an nine-pin, plug-in, Sub-D connector, x5
- **Restart lock** through a 4-position, plug-in, terminal block connector, x10 (A00 drives only)

---

## At a Glance, continued

---

### What's in this Chapter

This chapter contains the following topics.

Topic	Page
Wiring and I/O initial considerations	43
Wiring overview	44
Cable shield connections	46
Power wiring	48
Signal wiring	54
Analog I/O connections	61
Fault Relay and Digital I/O connections	63
Serial communications connections	65
Stepper-motor control interface connections	71

---

---

## Wiring and I/O Initial Considerations

---

### Initial Considerations

Some descriptions and illustrations contained in this chapter are provided as examples. Actual implementation depends on the application of the equipment; thus, appropriate variations are allowed provided they neither violate any safety precautions nor jeopardize the integrity of the equipment.

---



### **DANGER!**

### **ELECTRIC SHOCK HAZARD**

Before you wire and connect cables, ensure the mains power supply, the 24 Vdc bias power supply and the power supplies to any other connected equipment, are OFF. Ensure any cabinet to be accessed is first electrically disconnected, secured with a lock-out and tagged with warning signs.

**Failure to observe these safety instructions will result in death or serious injury.**

---

### Grounding

Ensure the drive mounting plate, servo motor housing and Analog Com for the controls are connected to common panel earth ground point.

---

*Continued on next page*

# Wiring Overview

## Overview of 17D HP Wiring Connections

The following diagram shows the wiring connections for the 17D HP drive.

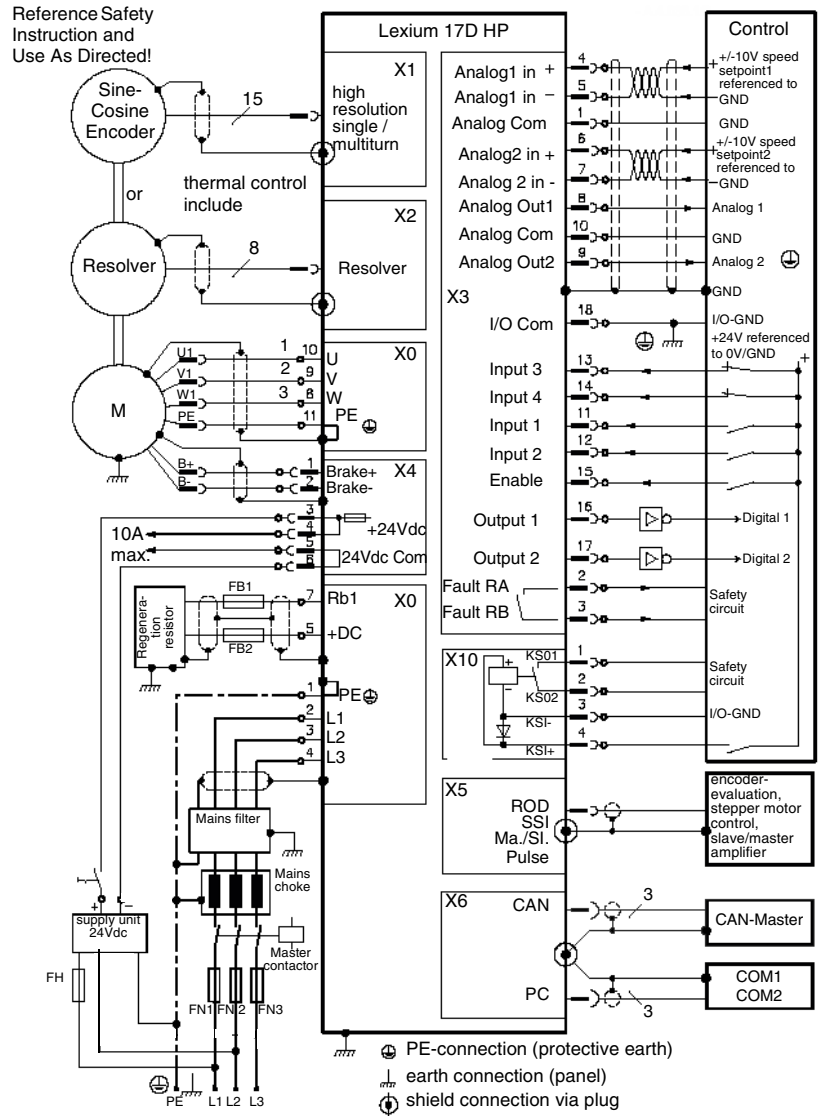



**Note:** The connectors described above appear in many wiring diagrams throughout the remainder of this document and are identified in those diagrams by their alphanumeric designations only (for example, X4); the term *connector* is excluded.

## Pin assignments for Lexium 17D HP Drive

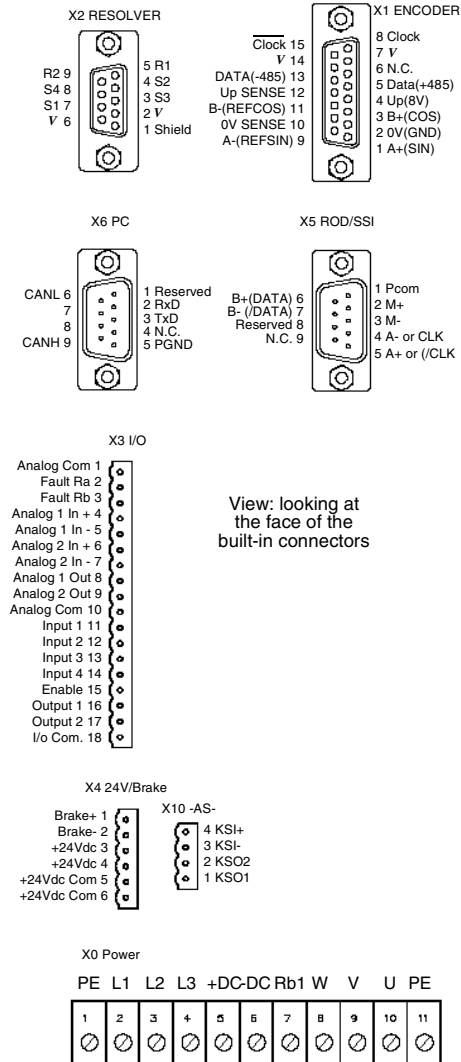

---

## Cable Shield Connections

---

### Connecting Cable Shields to the Front Panel

The following procedure and associated diagram describe how to connect cable shields to the front panel of the 17D HP drive:

Step	Action
1	Remove a length of the cable's outer covering and braided shield sufficient to expose the required length of wires.
2	Secure the exposed wires with a cable tie.
3	Remove approximately 30 mm of the cable's outer covering while ensuring the braided shield is not damaged during the process.
4	At the front panel of the drive, insert a cable tie into a slot in the shielding rail.
5	Use the previously inserted cable tie to secure the exposed braided shield of the cable firmly against the shielding rail.

---

*Continued on next page*

---

## Cable Shield Connections, continued

---

### Cable Shield Connection Diagram

The following diagram shows the cable shield connections at the front of the 17D HP drive.

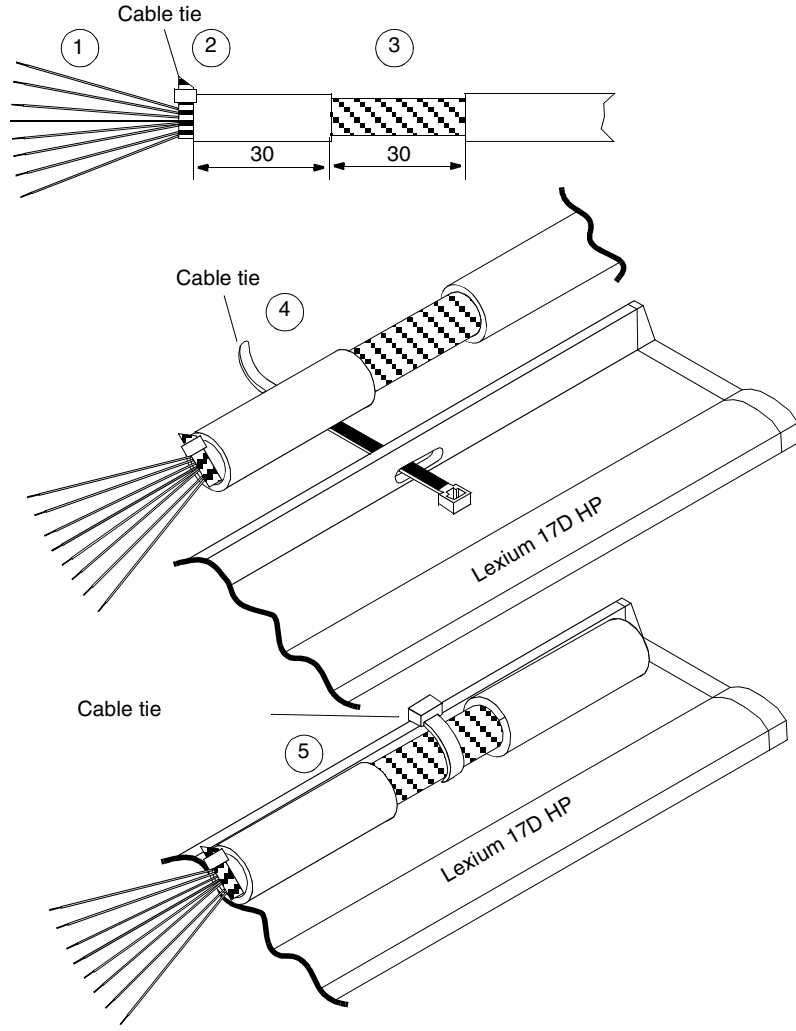

## Power Wiring

### AC Mains Power Supply Connection

The following diagram shows the connections for the AC mains power supply input to the 17D HP drive.

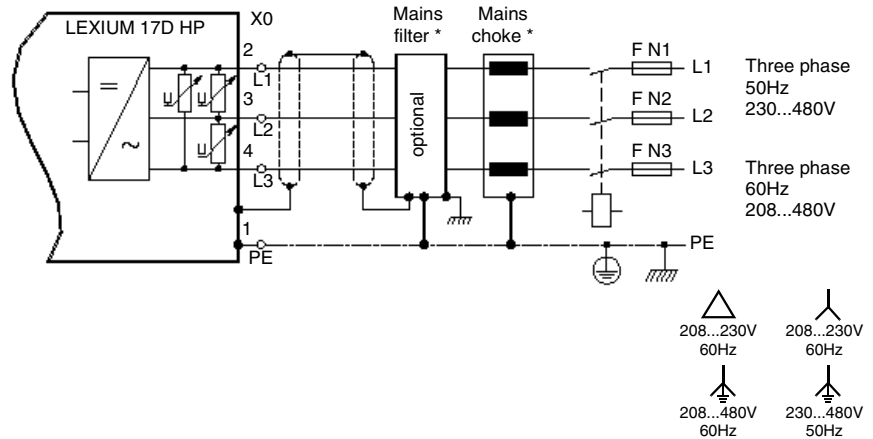

\*: They must be installed at a distance of one meter or less from the drive.

### Bias Supply Connection

The following diagram shows the connections for the bias power supply input to the 17D HP drive.

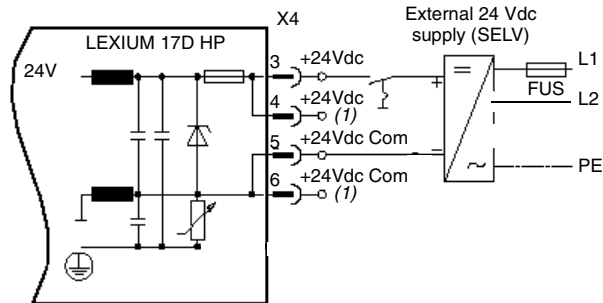

(1) The current must not exceed 10A through these pin.

*Continued on next page*

---

## Power Wiring, continued

---

### External Regen Resistor Connection

The following diagram shows the connections between the external Regen resistor and the 17D HP drive.

Fusing of the two lines to external Regen resistor is **mandatory**. Use high voltage AC/DC and fast fuses.

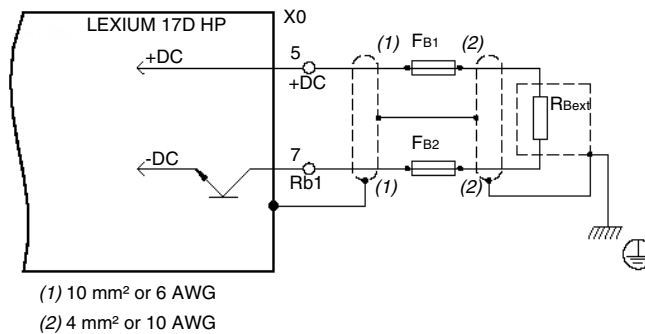

### Regen Circuit Functional Description

During braking, energy from the servo motor is returned to the drive and converted into heat in the Regen resistor. Operation of the Regen resistor is controlled by the Regen circuit using thresholds that are adjusted to the main supply voltage that is configured in the UniLink software. The following is an abbreviated functional description of the Regen circuit operation.

- **Individual drive** (not coupled through the DC Link circuit) - The circuit starts to respond at a DC Link voltage of 400V, 720V or 840V (depending on the supply voltage). If the energy fed back from the servo motor is higher than the preset Regen power, then the drive issues a "Regen power exceeded" signal and the Regen circuit will be switched off. Upon the next internal check of the DC Link voltage, an overvoltage will be detected, the fault relay contact will be opened and the drive will be switched off with the error message "Overvoltage".
- **Multiple drives** (coupled through the DC Link circuit) - In this case, the Regen energy is distributed equally among all the drives.

*Continued on next page*

---

## Power Wiring, continued

---

### Servo Motor (with Brake) Connection

The following diagrams show the connections between a servo motor and the 17D HP drive.

Connection between servo motor and drive

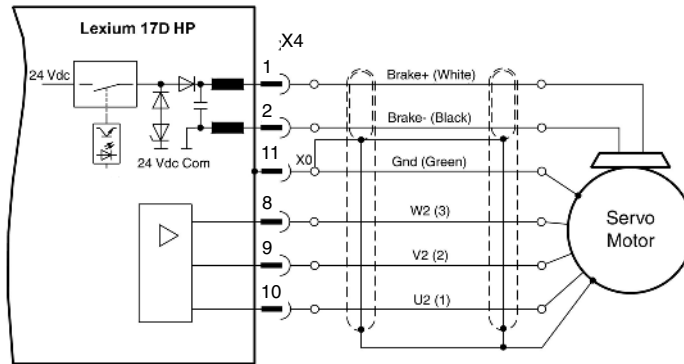

*Continued on next page*

---

## Power Wiring, continued

### Servo Motor (with Optional Dynamic Brake Resistors and Contactor) Connection

The following diagram shows the connections between a servo motor and the 17D HP drive when the optional dynamic brake resistors and associated contactor are incorporated.

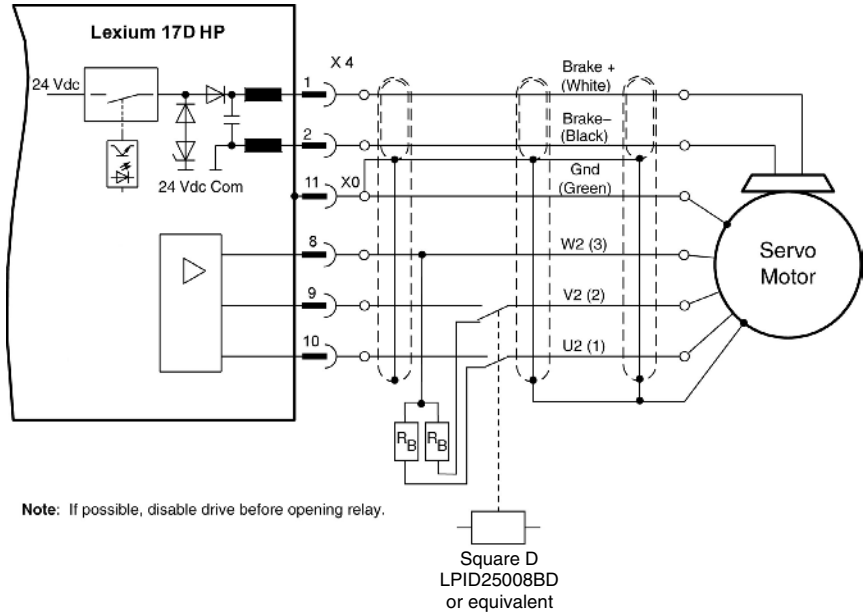

**Note:** If possible, disable drive before opening relay.

**BRAKING RESISTORS** - To determine the values of the braking resistors, use these formulas:

MINIMUM RESISTANCE (R<sub>db</sub>)

RESISTOR POWER RATING (P<sub>b</sub>)

$$R_b = \left( \frac{\text{max speed}}{1000} \right) \times \frac{\text{BEMF}}{I_{\text{MAX}} \times 0.8}$$

$$P_b = \frac{(I_{\text{MAX}} \times 0.8)^2 \times R_b}{10}$$

where: **max speed** is the maximum speed of the motor in RPM\*

**BEMF** is the back electromotive force of the motor in V / KPRM\*

**IMAX** is the maximum current of the motor in Amps RMS\*

\* These values are provided in the motor specification sheet.

*Continued on next page*

---

## Power Wiring, continued

---

### Servo Motor Holding-Brake Control Functional Description

A 24V holding brake in the servo motor is controlled directly by the 17D HP drive through software-selectable BRAKE parameter settings. The time and functional relationships between the ENABLE signal, speed setpoint, speed and braking force are shown in the following diagram.

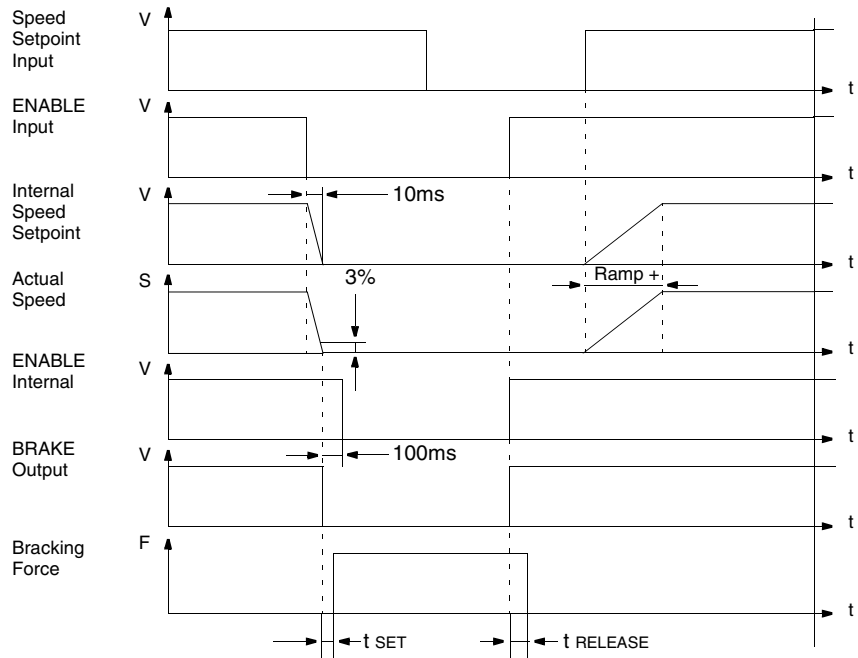

During the fixed ENABLE delay time of 100 ms, the internal speed setpoint of the drive is internally driven down a 10 ms ramp to 0 V. The 3% region of actual speed is scaled to  $V_{LIM}$ .



**Note:** The set and release times of the holding brake vary with the servo motor and thus must be considered when setting parameters.

---

## Power Wiring, continued

---



### WARNING! IMPACT HAZARD

The off-the-shelf configuration of the holding-brake function does not ensure the safety of personnel. In order to make this function safe for personnel, a normally open contact and a user-installed suppressor device (Metal oxide varistor or bidirectional transient voltage suppressor) must be incorporated into the brake circuit as shown in the following diagram.

**Failure to observe this precaution can result in severe injury or equipment damage.**

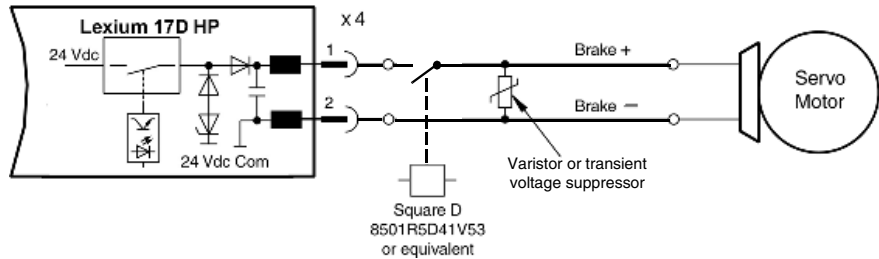

## Signal Wiring

### Resolver Connection

The following diagram shows the connections between the resolver and the 17D HP drive.



**Note:** The standard Lexium BPH series servo motors are equipped with two-pole, integral resolvers. The thermistor contact in the servo motor is connected via the resolver cable to the 17D HP drive.

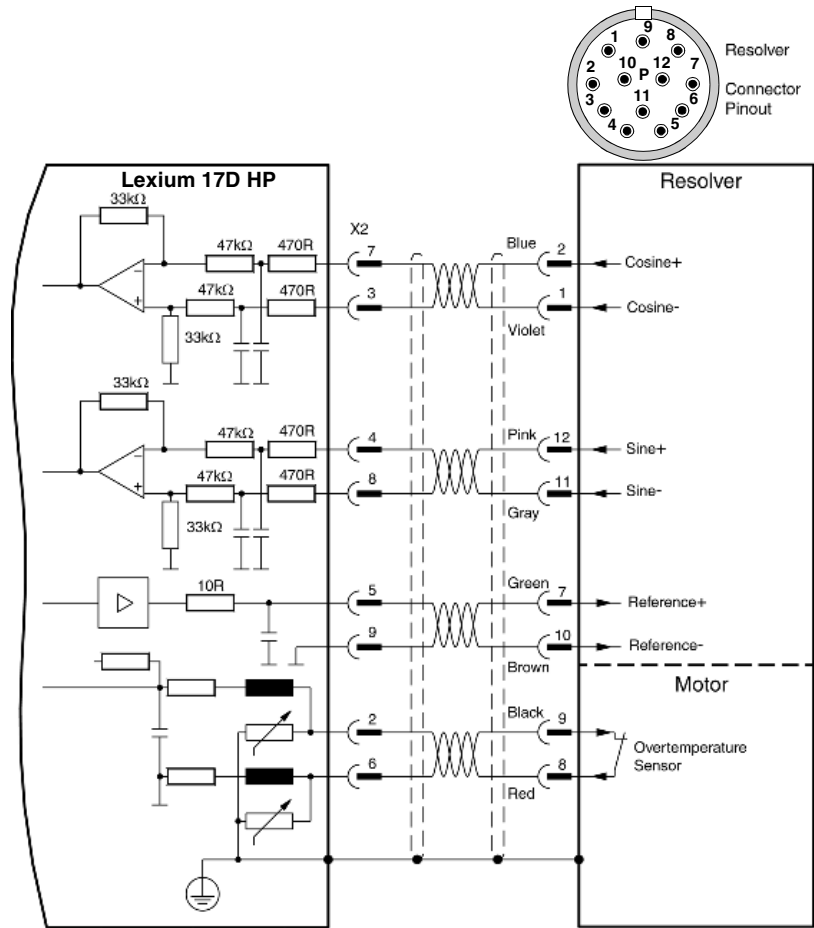

*Continued on next page*

## Signal Wiring, continued

### Encoder Input Connection

The following diagram shows the encoder input connections between the encoder and the 17D HP drive.



**Note:** The Lexium BPH series servo motors can be optionally fitted with a single-turn or multi-turn sine-cosine encoder, which is used by the 17D HP drive as the primary feedback device for operations requiring highly precise positioning or extremely smooth running. In addition, the thermistor contact in the servo motor is connected via the encoder cable to the 17D HP drive.

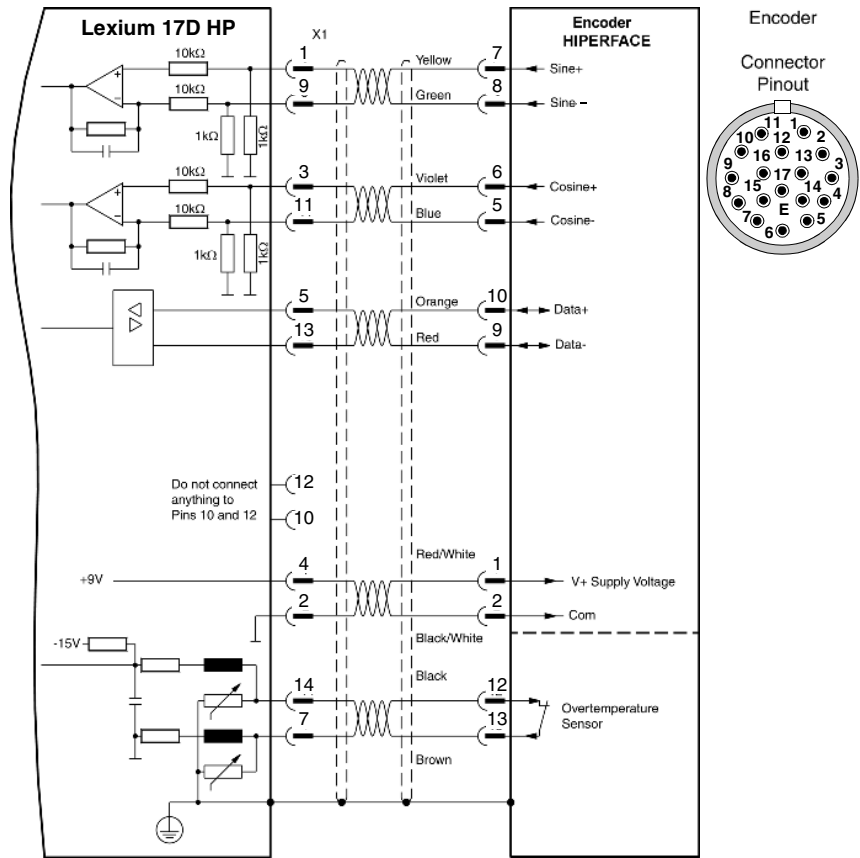

Continued on next page

---

## Signal Wiring, continued

---

### Incremental Encoder Emulation

#### ● Incremental-Encoder Output Connection

The following diagram shows the incremental encoder output connections between the 17D HP drive and the motion controller.



**Note:** The drivers are supplied from an internal supply voltage.

P<sub>Com</sub> must always be connected to the controller ground.

Use a cable with twisted pairs and shield (max. length: 10m.)

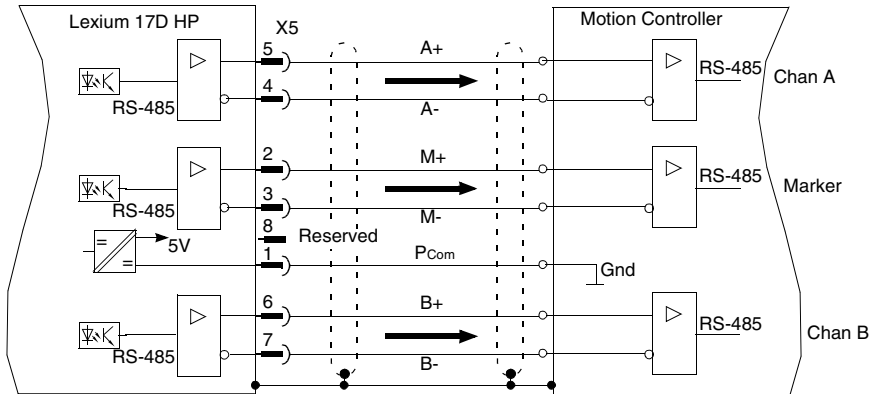

### Incremental-Encoder Output Functional Description

The position of the servo motor shaft is calculated using the cyclic-absolute signals from the resolver or encoder. The calculated position information is used to generate two incremental-encoder compatible signals (A and B) with a 90° phase difference and a marker pulse.

*Continued on next page*

---

## Signal Wiring, continued

---

### SSI Encoder Emulation

The following diagram shows the connections between a motion controller and the 17D HP drive.



**Note:** The drivers are supplied from an internal supply voltage. P<sub>Com</sub> must always be connected to the controller ground.

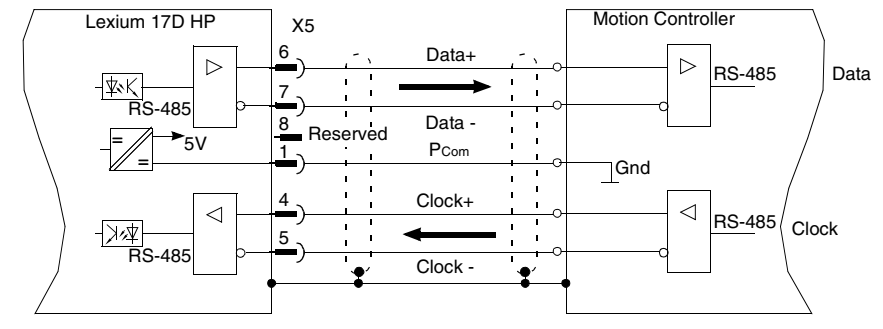

### SSI Encoder Output Functional Description

The SSI interface is synchronous serial absolute-encoder emulation. The position of the servo motor shaft is calculated using the cyclic-absolute signals from the resolver or encoder. This calculation is then used to generate a synchronous, serial, cyclic-absolute 12-bit information output that is compatible with the data format of normal commercial SSI absolute encoders. A total of 24 bits are transmitted as follows:

- The upper 12 bits contain the number of turns (multi-turn) or are fixed at zero (single turn).
- The lower 12 bits contain the cyclic absolute position information.

The signal sequence can be output in either:

- Gray code (standard)
- Binary code (parameter SSI-CODE)

The count increments positively when the motor shaft is rotating clockwise (when viewed from the shaft end).

---

*Continued on next page*

---

## Signal Wiring, continued

---

### Diagram of master-slave operation

The encoder interface can be used to link one or more 17D HP drives together in a master-slave operation, as shown in the following diagram. The UniLink software allows you to setup the parameters for the slave drive(s).

 **Note:** In this configuration, the analog setpoint inputs are disabled, a Analog Com and I/O Com (connector X3) must be connected together.

---

### Incremental encoder emulation

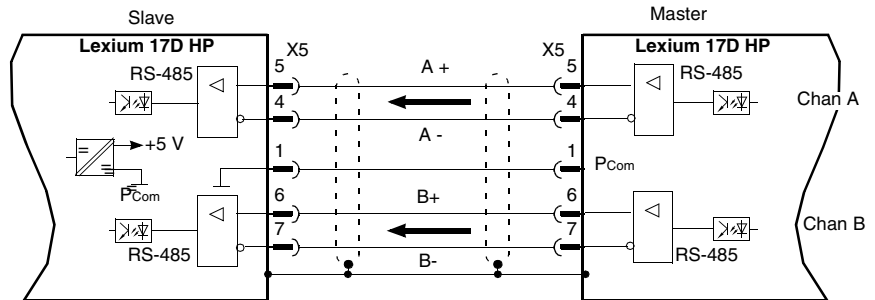

 **Note:** Up to 16 slaves drives can be controlled by the master drive.

---

### SSI encoder emulation

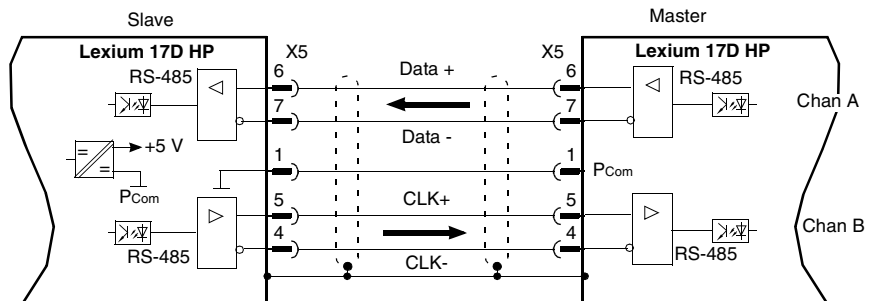

 **Note:** Only one slave drive can be controlled by the master drive.

---

*Continued on next page*

## Signal Wiring, continued

### External Incremental encoder connection

The following diagram shows the incremental encoder input connections between the 17D HP drive and an external incremental encoder.

**Note:** The receivers are supplied from an internal supply voltage.  $P_{Com}$  must always be connected to the encoder ground. Incremental encoder is powered by an external Power Supply.

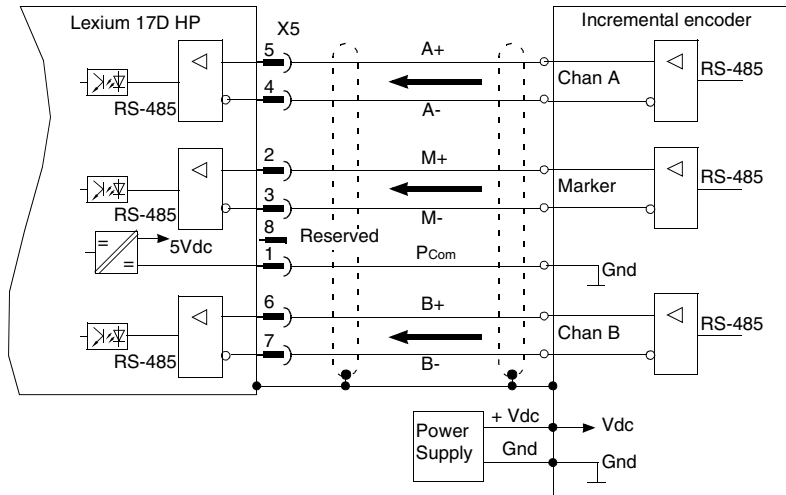

---

## Signal Wiring, continued

---

### External SSI encoder connection

The following diagram shows the connections between an external SSI encoder and the 17D HP drive.



**Note:** The drivers are supplied from an internal supply voltage.  $P_{Com}$  must always be connected to the encoder ground. SSI encoder is powered by an external Power Supply

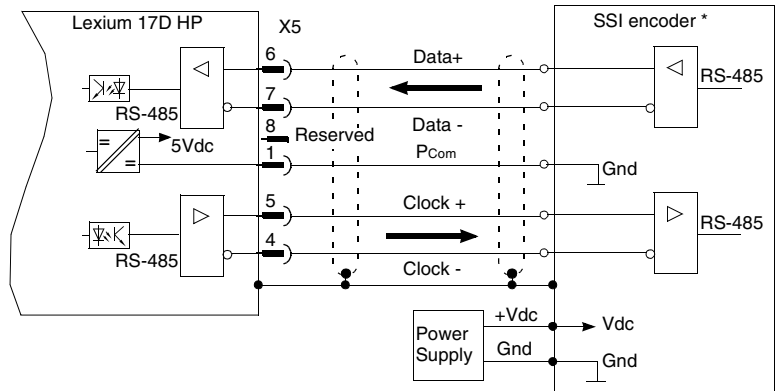

\* See Telemecanique XCC range

---

---

## Analog I/O Connection

---

### Analog Inputs

The following diagram shows the connections between the two fully programmable, differential analog inputs on the 17D HP drive and a user device. (Refer to the list of pre-programmed functions contained in the UniLink online help.)



**Note:** The Analog Com must always be connected to the user device Com as a ground reference.

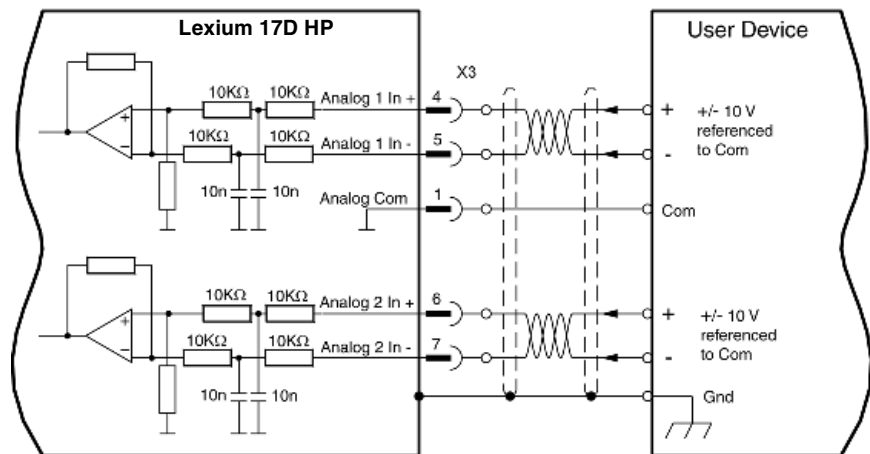

---

### Servo Motor Rotation Direction

The standard setting for direction of positive rotation of the servo motor shaft is clockwise (looking at the shaft end) and is achieved as follows:

- Positive voltage on connector X3, between terminals 4 (+) and 5 (-), or
- Positive voltage on connector X3, between terminals 6 (+) and 7 (-)

To reverse the direction of rotation, change the ROT. DIRECTION parameter in the "Speed controller" window; this window is accessed via the UniLink Configuration software.

*Continued on next page*

---

## Analog I/O Connection, continued

---

### Analog Outputs

The following diagram shows the connections between the two programmable, analog outputs on the 17D HP drive and a typical user device. (Refer to the list of pre-programmed functions in the UniLink online help.)

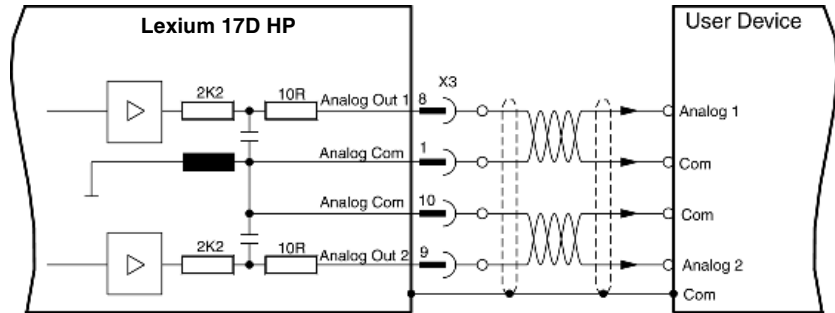

The outputs (+/-10V with 10-bit resolution) can be configured for various monitoring functions such as current or actual speed. The default settings are:

- **Analog Out 1:** Tachometer voltage (speed). The output delivers  $\pm 10V$  at the preset limit speed.
- **Analog Out 2:** Current setpoint (torque). The output delivers  $\pm 10V$  at the preset peak current (effective RMS value).
- **Note:** Output impedance of the analog outputs (2K2) must be taken into account when there is a connection to an user device: divider due to the input impedance of the user device.

## Fault Relay and Digital I/O Connection

### Digital Inputs and Outputs

The following diagram shows the connections between the fault relay, the four fully-programmable, digital inputs, dedicated enable input and two digital outputs on the 17D HP drive and typical user devices. (A list of pre-programmed functions is contained in the UniLink online help.)

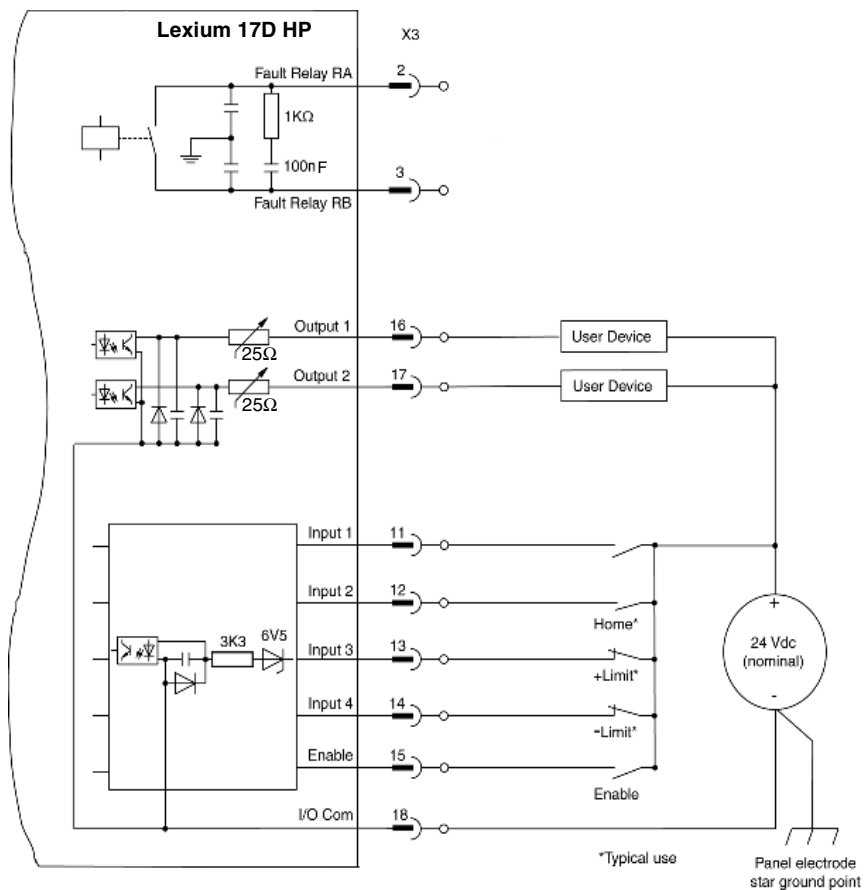

Continued on next page

---

## Fault Relay and Digital I/O Connection, continued

---

### Using Functions Pre-programmed into the Drive

**Fault Relay-** The isolated fault relay contacts are closed during normal operation and open when a fault condition exists. The relay state is not affected by the enable signal, I<sup>2</sup>t limit or warnings. All faults cause the Fault RA/RB contact to open and the switch-off of the output stage. A list of error messages can be found in chapter Troubleshooting.

**Digital Inputs 1, 2, 3 and 4** - You can use the four digital inputs to initiate pre-programmed functions that are stored in the drive.

Normally, the Input 3/Input 4 terminals (X3/13 and X3/14) are programmed for the connection of limit-switches. When they are connected as limit-switch positive/negative (PSTOP/NSTOP), a low PSTOP signal (open) on input terminal X3-13, inhibits the positive direction of axis rotation and a low NSTOP signal (open) on input terminal X3-14, inhibits the negative direction of axis rotation. In both cases, the ramp function remains effective.

---



### WARNING!

#### LIMIT SWITCH HAZARD

Once they are tripped, the limit switches must remain in that condition (PSTOP/ NSTOP signals low) in order to inhibit the corresponding direction of motion.

**Failure to observe this precaution can result in severe injury .**

---

**Digital Outputs 1 and 2** - You can use the two digital outputs to send messages from pre-programmed functions that are stored in the drive.

**Enable Input** - This is a dedicated, level-sensitive (as opposed to edge-sensitive) hardware input which will enable the output stage of the drive when 24 Vdc is applied and no fault conditions exist.



**Note:** The hardware enable is powered up upon detection of state sense versus transition sensitivity. Refer to the UniLink on-line help for software enable information.

---

---

## Serial Communications Connection

---

### Serial Communications Connection Diagram

The following diagram depicts the RS-232 communication connection between the Lexium 17D HP and a PC.

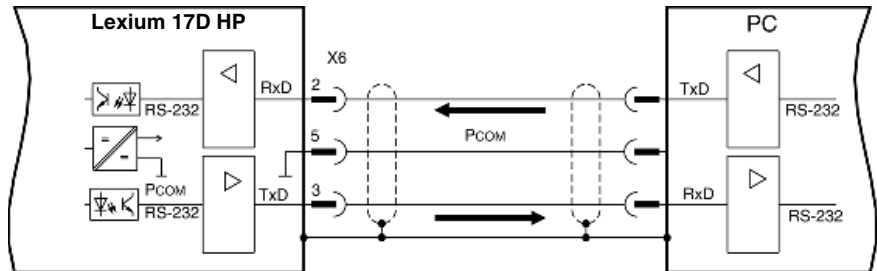

*See wiring in appendix D*

The setting of the operating, position control, and motion-block parameters can be carried out with an ordinary commercial PC.

Connect the PC interface (X6) of the servo amplifier **while the supply to the equipment is switched off** via a normal commercial 3-core cable to a serial interface on the PC. **Do not use a null-modem link cable!**

The interface is electrically isolated through an optocoupler, and is at the same potential as the CANopen interface.

---

---

## Serial Communications Connection, continued

---

### CANopen Interface

The interface for connection to the CAN bus (default 500 kBaud). The integrated profile is based on the communication profile CANopen DS301 and the drive profile DSP402.

The following functions are available in connection with the integrated position controller:

Jogging with variable speed, reference traverse (zeroing), start motion task, start direct task, digital setpoint provision, data transmission functions and many others.

Detailed information can be found in the CANopen manual. The interface is electrically isolated by optocouplers, and is at the same potential as the RS232 interface. The analog setpoint inputs can still be used.

**If the analog setpoint inputs are not used, then Analog Com and I/O Com (terminal X3) must be joined together !**

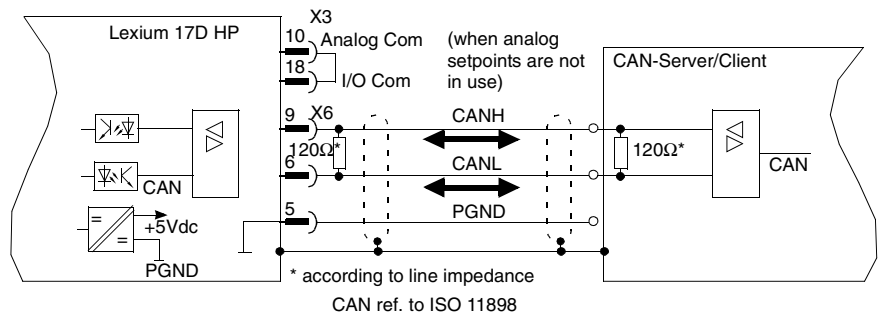

---

## Serial Communications Connection, continued

---

### CAN bus cable

To meet ISO 11898 you should use a bus cable with a characteristic impedance of  $120\ \Omega$ . The maximum usable cable length for reliable communication decreases with increasing transmission speed. As a guide, you can use the following values which we have measured, but they are not to be taken as assured limits:

<b>Cable data:</b>	Characteristic impedance	100-120 $\Omega$
	Cable capacitance	max. 60 nF/km
	Lead resistance (loop)	159.8 $\Omega$ /km

### Cable length, depending on the transmission rate

Transmission rate (kBauds)	max. cable length (m)
1000	20
500	70
250	115

Lower cable capacitance (max. 30 nF/km) and lower lead resistance (loop, 115  $\Omega$ /km) make it possible to achieve greater distances. (Characteristic impedance  $150 \pm 5\ \Omega$  => terminating resistor  $150 \pm 5\ \Omega$ ).

For EMC reasons, the SubD connector housing must fulfill the following conditions:

- metal or metallized housing
- Shield connection to housing

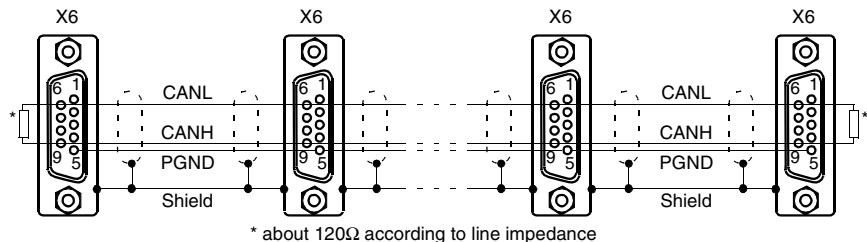

---

**Expansion module  
AM02CA001V000**

The X6 connector on the Lexium drive serves as an interface for both the RS232 and CAN bus protocols. This means that a special cable would be necessary when using both the RS232 link and the CAN bus link simultaneously. Moreover, the pin assignment of the X6 connector is not in accordance with the Standards.

This new AM02CA001V000 module addresses these issues as it includes :

- one male SubD connector for the RS232 link,
- two SubD connectors for the CAN bus interface (these two connectors are wired in parallel).

Additionally, the pin assignment of the three connectors is in accordance with the Standards.

The module also includes a switch that allows the connection of the CAN bus termination resistor (120 Ohm).

---

**Position of the connectors**

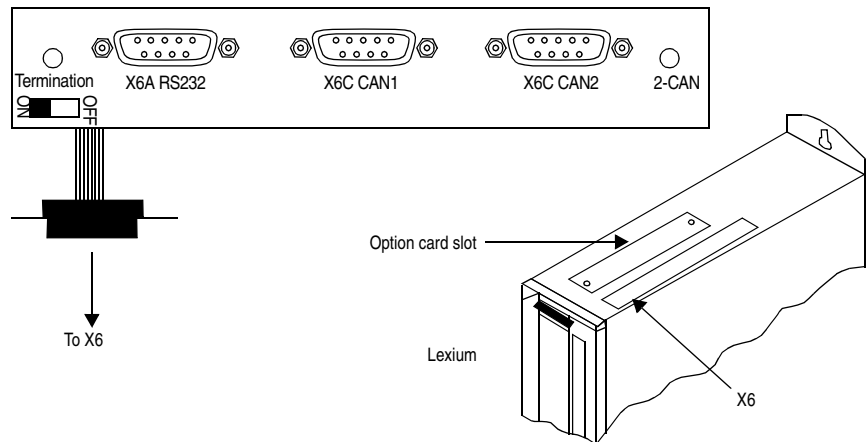

---

**Fitting the expansion module**

Please, follow the procedure below :

- Make sure that power to the drive is off,
- Remove the two metal spacers that are screwed on to the module and retain the two screws,
- With the help of a suitable screwdriver, remove delicately, from the drive, the metal cover that covers the slot for the option cards,

- Take care so that no small parts (screw for example) fall inside the drive,
- Screw the two spacers into the threaded holes used for mounting the option cards,
- Position the module on the two spacers (pay attention to the orientation ensuring the X6A connector of the module is adjacent to the X6 connector of the drive),
- Screw in the two screws,
- Connect the SubD connector of the module to the X6 connector of the drive.

### Connection technology

Standard shielded cables can be used for the RS232 and CAN interfaces.

**If the servo amplifier is the last device on the CAN bus, then the switch for the bus termination must be set to ON. Otherwise, the switch must be set to OFF (condition as delivered).**

### Connector assignmentss

RS232		CAN1 or CAN2	
X6A Pin	Signal	X6B or X6C in	Signal
1	Vcc	1	
2	RxD	2	CAN-Low
3	TxD	3	CAN-GND
4		4	
5	GND	5	
6		6	
7		7	CAN-High
8		8	
9		9	

---

**Connection  
diagram**

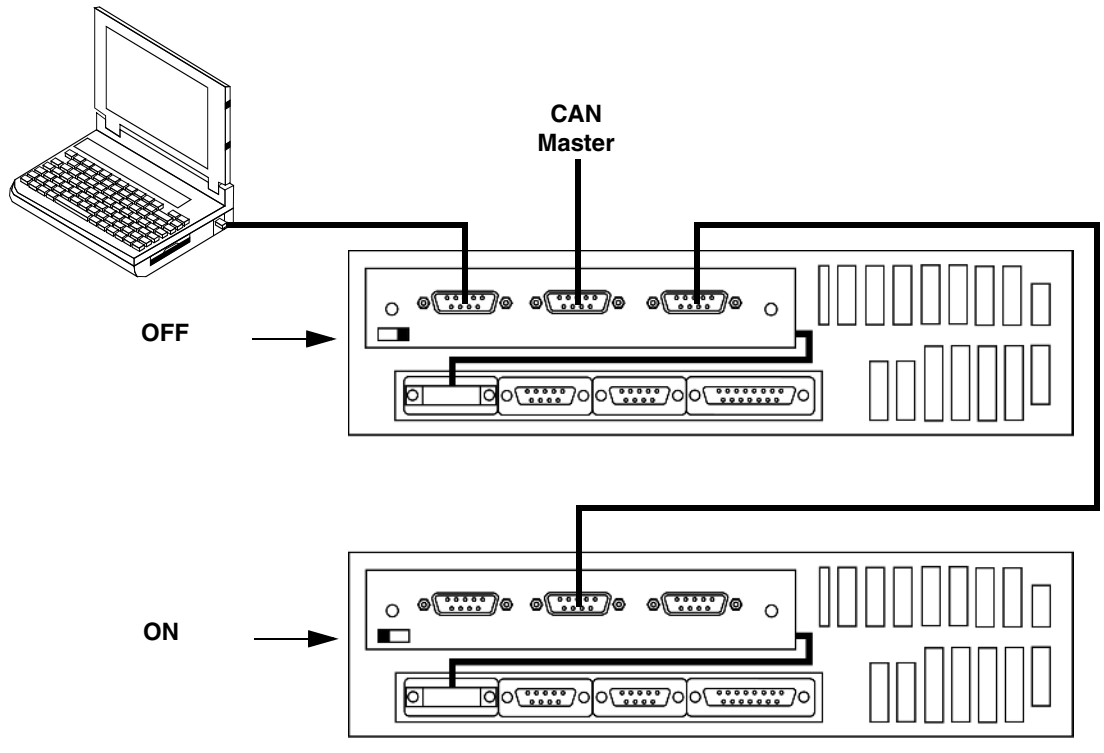

---

## Stepper Motor Control Interface Connection

---

### Stepper-Motor Control Interface Connection Functional Description

This interface can be used to connect the servo drive to a third-party stepper motor controller. The parameters for the drive are set using the UniLink software and the number of steps are adjustable to allow the drive to correlate to the step-direction signals of any stepper-motor controller. In this configuration, the analog inputs are disabled and the drive can provide various monitoring signals.

---

### Stepper-Motor Control Interface Connection Diagram

The following diagram depicts the communication connection between the Lexium 17D HP and a stepper-motor controller.

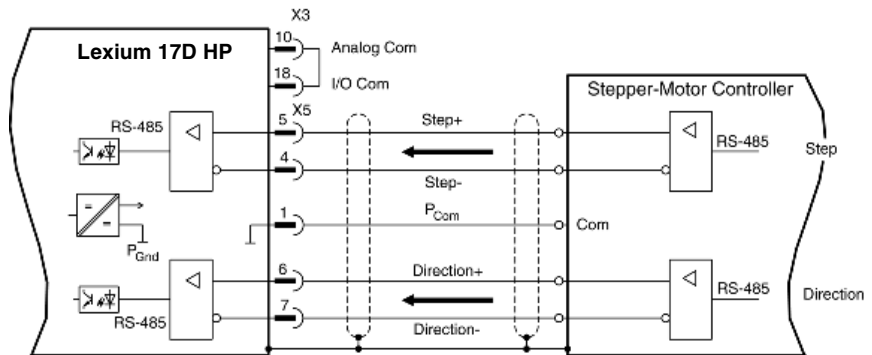

*Continued on next page*

---

## Stepper Motor Control Interface Connection, continued

---

### Stepper-Motor Speed Profile and Signal Diagram

The following is the speed profile and signal diagram of the stepper-motor configuration.

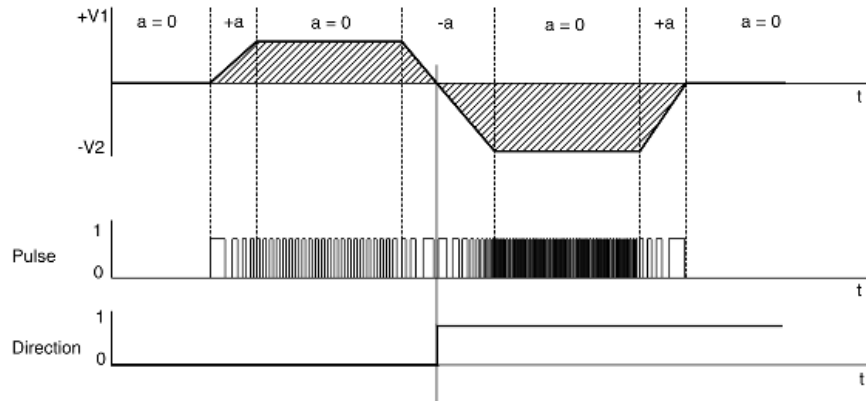

**Derivatives:**

- Distance traversed  $s$  ----- number of pulses
- Velocity  $v$  ----- pulse frequency
- Acceleration  $a$  ----- change of pulse frequency

---

# System Operation



---

## At a Glance

### What's in this Chapter

This chapter provides information on operating the Lexium 17D HP series servo drives and includes the following topics:

Topic	Page
Powering up and powering down the system	74
Description of the restart lock -AS-	78
Procedure for verifying system operation	86
Front panel controls and indicators	90

---

---

## Powering Up and Powering Down the System

---

### Power-on and Power-off Characteristics

The following diagram illustrates the functional sequence that occurs when the drive is turned on and off.

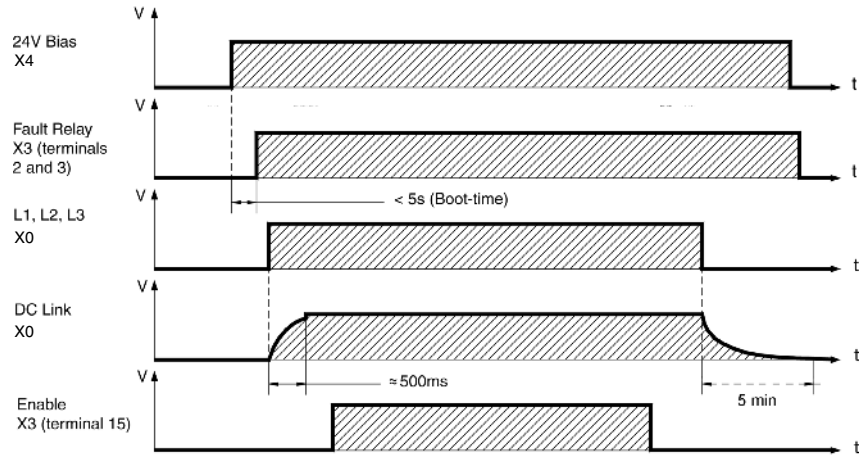

*Continued on next page*

---

## Powering Up and Powering Down the System, continued

---

### Stop Function

If a fault occurs the output stage of the servo amplifier is switched off and the Fault RA/RB contact is opened. In addition, a global error signal can be given out at one of the digital outputs (terminals X3/16 and X3/17). These signals can be used by the higher-level control to finish the current PLC cycle or to shut down the drive (with additional brake or similar.).

The built-in restart lock -AS- can be used to switch off the drive via a positive action safety relay, so that personnel safety is ensured at the drive shaft.

Instruments which are equipped with a selected "Brake" function use a special sequence for switching off the output stage.

The Stop functions are defined in EN 60204 (VDE 0113), Para. 9.2.2, 9.2.5.3.

There are three categories of Stop functions:

- **Category 0:**

Shut down by immediately switching off the supply of energy to the drive machinery (i.e. an uncontrolled shut down);

- **Category 1:**

A controlled shut down, during which the supply of energy to the drive machinery is maintained to perform the shut-down, and where the energy supply is only interrupted when the shut-down has been completed;

- **Category 2:**

A controlled shut down, where the supply of energy to the drive machinery is maintained.

Every machine must be equipped with a Stop function to Category 0. Stop functions to Categories 1 and/or 2 must be provided if the safety or functional requirements of the machine make this necessary.

---

*Continued on next page*

---

## Powering Up and Powering Down the System, continued

---

### Emergency Stop strategies

The Emergency Stop function is defined in EN 60204 (VDE 0113), Para. 9.2.5.4.

#### Implementation of the Emergency Stop function:

- **Category 0:**

The controller is switched to "disable", the electrical supply (400VAC) is disconnected.

The motor must be held by an electromagnetic holding device (brake).

In multiaxis systems with connected DC-link bus (intermediate circuit) the motor leads have to be disconnected by a changeover switch and short-circuited by resistors connected in a star configuration.

- **Category 1:**

If hazardous conditions can result from an emergency stop switch-off with an unbraked run-down, then the drive can be switched off by a controlled shut-down.

Stop Category 1 permits electromotive braking with a switch-off when zero speed has been reached. Safe shut-down can be achieved, when the loss of the mains supply is not rated as a fault and the control takes over the disabling of the servo amplifier.

In the normal situation, only the supply power is switched off in a safe manner.

The 24V auxiliary supply remains switched on.

---

*Continued on next page*



---

## Description of the restart lock -AS-

---

### **Advantages of the restart lock**

A frequently required application task is the protection of personnel against the restarting of drives. This can not be achieved by an electronic inhibit, but must be implemented with mechanical elements (positively driven relay contacts).

To get round this problem, up to now either the main contactor in the mains supply line was switched off, or another contactor was used to disconnect the motor from the servo amplifier.

The disadvantages of this method are :

- the DC-link has to be charged up again at restart
- wear on the contacts of the contactors, caused by switching under load
- extensive wiring required, with additional switching components

The restart lock -AS- avoids these disadvantages. A safety relay in the servo amplifier is activated either by the PLC or manually. Positively driven contacts provide a safe disconnection of the amplifier, the setpoint input of the servo amplifier is inhibited, and a signal is sent to the safety circuit.

### **Advantages of the restart lock -AS- :**

- the DC-link remains charged up, as long as the mains supply line remains active
- only low voltages are switched, so there is no contact wear
- very little wiring is required
- the functionality and the personnel safety when using the circuit recommendations in this documentation have been approved by the trade liability association.

---

*Continued on next page*

---

## Description of the restart lock -AS-, continued

---

### Functional description

The connector (X10) is mounted on the front panel of the Lexium 17 D HP. The coil connections and a make (n.o.) contact of a safety relay are available through 4 terminals on this connector.

Two contacts switch off the driver supply of the output stage in the servo amplifier, and short the internal setpoint signal to Analog Com (0 V).

The make (n.o.) contact used for monitoring is looped into the control circuit.

If the safety relay is not energized, then the monitoring contact is open and the servo amplifier is ready for operation.

If the drive is electronically braked, the servo amplifier is disabled and the motor-holding brake is on, then the safety relay is energized (manually or by the controls).

The supply voltage for the driver circuit of the output stage is switched off in a safe manner, the internal setpoint is shorted to 0V, and the monitoring contact bridges the safety logic in the control circuit of the system (monitoring of protective doors etc.)

Even if the output stage or driver is destroyed, it is impossible to start the motor.

If the safety relay itself is faulty, then the monitoring contact cannot bridge the safety logic of the system. Opening the protective devices will then switch off the system.

---

*Continued on next page*

---

## Description of the restart lock -AS-, continued

---

### Block diagram

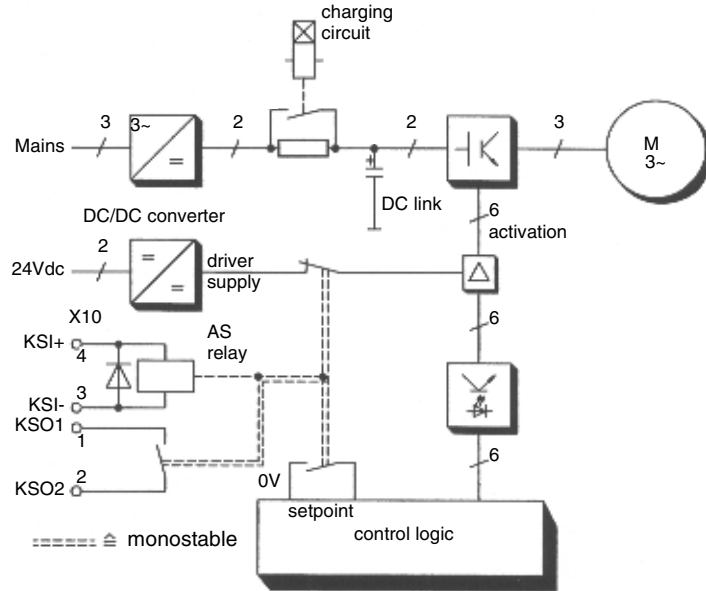

 **Note:** AS relay :

Its main features are:

- according to EN 50205, IEC 255, IEC 664
- monostable
- high mechanical service life
- high switching reliability
- approvals TUV, UL and CSA.

*Continued on next page*

---

## Description of the restart lock -AS-, continued

---

### Signal diagram (sequence)

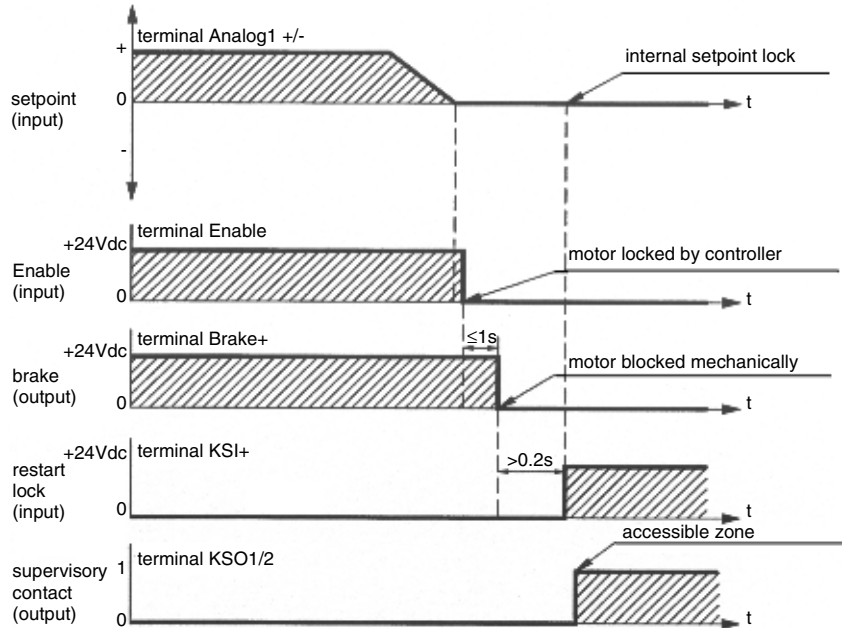

 **Note:** Restart lock input must not be activated when the drive is enabled. The diagram above must be respected.

*Continued on next page*

---

## Description of the restart lock -AS-, continued

---

### Installation / Commissioning

#### Safety instructions

- Observe the prescribed use of the restart lock -AS-
- The monitoring contacts (KSO1/2) for each amplifier with an restart lock -AS- must be looped into the control circuit. This is vital, so that a malfunction of the internal safety relay or a cable break can be recognized.
- If the restart lock -AS- is automatically activated by a control system (KSI1/2), then make sure that the output of the control is monitored for possible malfunction. This can be used to prevent a faulty output from activating the restart lock -AS- while the motor is running.
- **Keep to the following functional sequence when the restart lock -AS- is used:**
  1. Brake the drive in a controlled manner (speed setpoint = 0V)
  2. When speed = 0 rpm, disable the servo amplifier (enable = 0V)
  3. If there is a suspended load, apply an additional mechanical block to the motor
  4. Activate the restart lock -AS

#### Functional test

The functioning of the restart lock must be tested during commissioning, after every alteration in the wiring of the system, or after exchanging one or more components of the system.

1. Stop all drives, with setpoint 0V, disable drives, mechanically block any suspended loads
2. Activate the restart lock -AS-.
3. Open protective screens (enclosure doors, etc) but do not enter hazardous area
4. Pull off the X10 connector from an amplifier; **the Mains contactor must drop out**
5. Reconnect X10. Switch on Mains contactor again.
6. Repeat steps 4 and 5 for each individual servo amplifier.

---

*Continued on next page*

---

## Description of the restart lock -AS-, continued

---

### Connection diagram

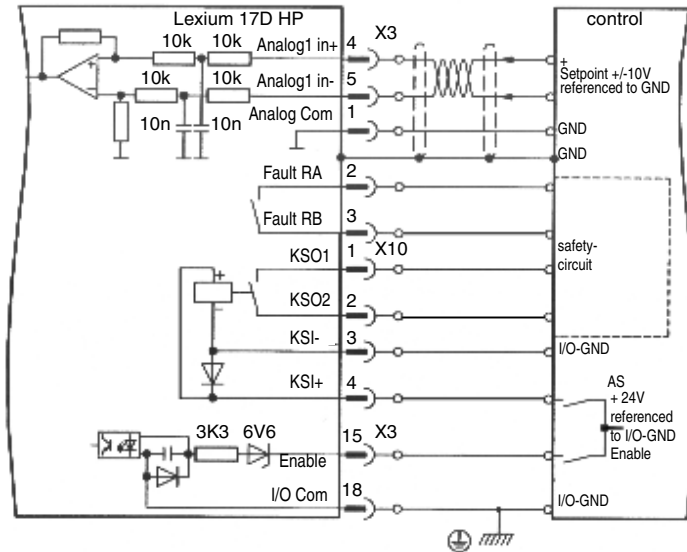

*Continued on next page*

---

## Description of the restart lock -AS-, continued

---

### Application examples

#### **Moving single axes or axis-groups in setting-up operation**

In setting-up operation, people will frequently be within the danger zone of the machinery. Axes will normally be moved under the control of permission switches. An additional switch-off of the unused axes, by means of the restart lock, increases the safety margin and avoids the repeated switching of main contactors or motor.

#### **Switching off grouped axes with separate working areas**

Even when several Lexium 17D HP are operating off a common mains supply and DC-link, it is possible to set up groups for separate working areas. These groups can then be switched off separately for personnel safety. For this purpose, we have provided you with a suggested circuit (mains supply circuit and control circuit for 2 separate working groups which have interconnected DC-links and a common mains supply voltage).

---

*Continued on next page*

## Description of the restart lock -AS-, continued

### Control circuit

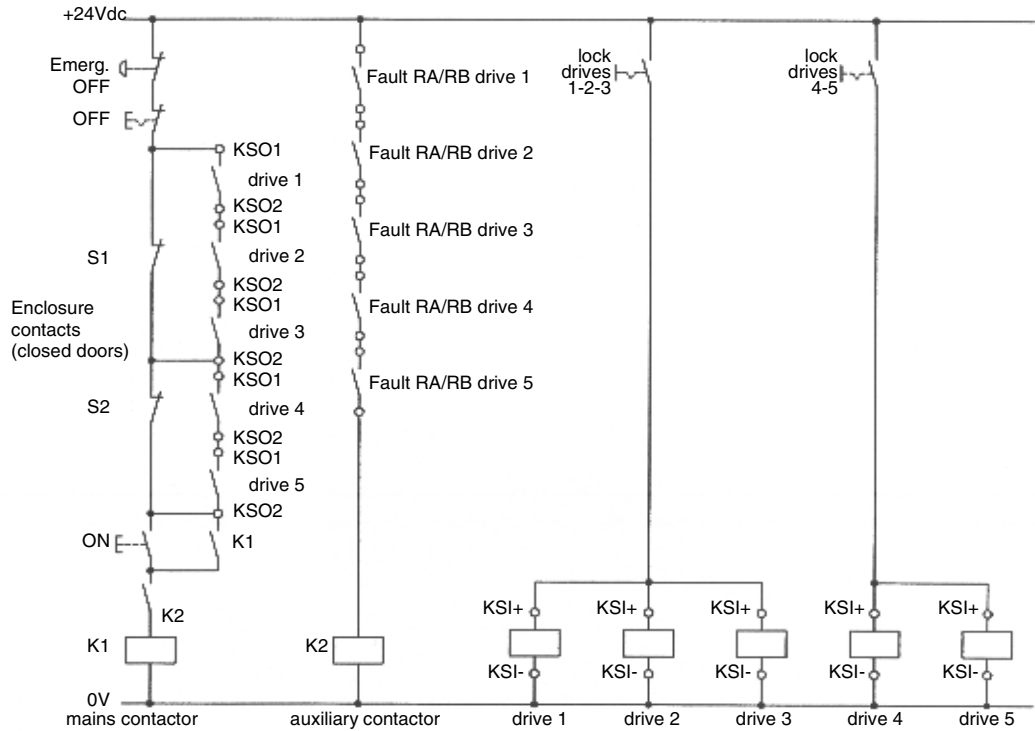

- Note:**
- Servo drives 1, 2 and 3 inside the enclosure 1 with door contact S1
  - Servo drives 4 and 5 inside the enclosure 2 with door contact S2

---

## Procedure for Verifying System Operation

---

### Overview

The following procedure and associated information verifies operation of the system without creating a hazard to personnel or jeopardizing the equipment. This procedure presumes the drive has been configured with UniLink software in OpMode 1 as a speed controller with analog input command.



**Note:** Default parameters for each BPH series motor are loaded into your drive at the factory and contain valid and safe values for the current and speed controllers. A database for the servo motor parameters is stored in the drive. During commissioning, you must select the data set for the connected servo motor and store it in the drive. For most applications, these settings will provide good servo loop efficiency. For a description of all parameters and motor tuning, see the UniLink online help.

---

*Continued on next page*

---

## Procedure for Verifying System Operation, continued

---

### Quick Tuning Procedure

This procedure will enable you to rapidly assess the operational readiness of the system.

Step	Action
1	<p>Disconnect the drive from the power source.</p> <p> <b>WARNING!</b></p> <p><b>MECHANICAL MOVEMENT HAZARD</b></p> <p>Ensure the motor is securely mounted and that the load is disconnected from the motor.</p> <p><b>Failure to observe this precaution can result in severe injury or equipment damage.</b></p>
2	Ensure 0 V is applied to the enable input (connector X3, terminal 15).
3	Connect the PC to the drive via the serial communications cable.
4	Turn on the 24 Vdc bias supply. After the initialization procedure (< 5 seconds) the status is shown in the LED display.
5	Switch on the PC, start the UniLink software and select the serial communication port to which the drive is connected. (The parameters that are stored in the SRAM of the drive are transferred to the PC.)
6	<p>Use the UniLink software to check/establish the following:</p> <ul style="list-style-type: none"><li>● <b>Drive Parameters</b> - Set/restore the drive parameters to the factory default values</li><li>● <b>Supply voltage</b> - Set the supply voltage to the actual mains supply voltage</li><li>● <b>Servo Motor</b> - Select the applicable BPH servo motor.</li><li>● <b>Feedback</b> - Ensure the feedback matches the feedback unit in the servo motor</li></ul>

---



*Continued on next page*

---

## Procedure for Verifying System Operation, continued

---

### Quick Tuning Procedure, continued

Step	Activity
7	<p>Check safety devices such as hardware limit switches, emergency stop circuitry and so forth.</p> <p> <b>WARNING!</b></p> <p><b>MECHANICAL MOVEMENT HAZARD</b></p> <p>Ensure personnel, tools and all other obstructions are clear of the equipment.</p> <p><b>Failure to observe this precaution can result in severe injury or equipment damage.</b></p>
8	<p>Apply 0V to the analog command input on connector X3, terminals 4 and 5 or 6 and 7.</p>
9	<p>Turn on the AC mains power supply, drive being disabled.</p>
10	<p>Enable 24 Vdc on connector X3, terminal 15. Observe that 500 ms after the power supply was switched on, the servo motor is motionless with a standstill torque of <math>M_0</math>.</p>
11	<p>Using the UniLink Oscilloscope Service Function, program a small 50-rpm velocity command. If the servo motor oscillates, the Kp parameter in the "speed controller" menu page must be adjusted.</p> <p> <b>Note:</b> The Kp parameter may have to be adjusted after connecting the load. Refer to UniLink on-line help for more tuning information.</p>

 **Note:** The hardware enable is powered up upon detection of state sense versus transition sensitivity.

---

*Continued on next page*

---

## Procedure for Verifying System Operation, continued

---

### Parameter settings

A default parameter set is loaded into your servo amplifier by the manufacturer. This contains valid and safe parameters for the current and speed controllers.

A database for motor parameters is stored in the servo amplifier. During commissioning you must select the data set for the motor that is connected and store it in the servo amplifier. For most applications these settings will already provide good control loop characteristics.

An exact description of all parameters and the possibilities for optimizing the control loop characteristics can be found in the help of Unilink

### Multi-Axis System

You can connect servo amplifiers together and to your PC if they have different addresses (see next page)

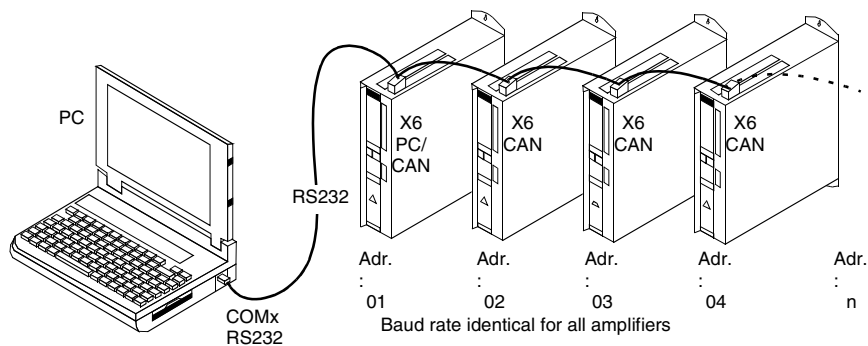

With the PC connected to just one servo amplifier you can now use the setup software to select all amplifiers through the preset station addresses and set up the parameters.

---

---

## Front Panel Controls and Indicators

---

### Keypad Operation

The operation of the keypad on the front panel of the drive is described in the following table. The two keys can be used (as an alternative to using the PC) to specify and enter the address for the drive.

Key	Function
▲ ▼	<b>From the initial display,</b> <b>Press once one of the two keys</b> to display the current address.
▲	<b>Press once:</b> Increments address by 1 <b>Press twice in rapid succession:</b> Increments address by 10
▼	<b>Press once:</b> Decrements address by 1 <b>Press twice in rapid succession:</b> Decrements address by 10
▲ ▼	<b>Press and hold right key, then press left key:</b> Enters the address specified above.

---

*Continued on next page*

---

## Front Panel Controls and Indicators, continued

---

### LED Display

The alphanumeric display indicates drive power status conditions, error codes and warning codes. The power status conditions are shown below; error and warning codes are described in the pages that follow.

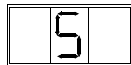

Option -AS- is active

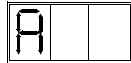

Reset input active

The "Reset" function is assigned to a digital input where a High signal is connected

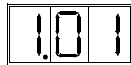

Status 1 : 24 Vdc switched on. Displays the firmware version then after 1 second displays Status 2, 3 or 4.

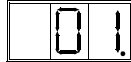

Status 2 : 24 Vdc switched on. Displays the continuous current rating of the drive; in this case, 1A. (Dot will be flashing.)

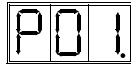

Status 3 : 24 Vdc and main supply switched on but drive is disabled. (Dot will be flashing.)



Status 4 : 24 Vdc and main supply switched on but drive is enabled. (Dot will be flashing.)

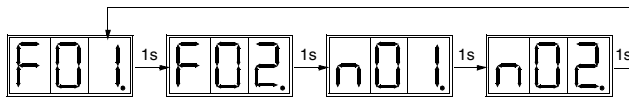

fault / warning signal:  
each error / warning that  
has occurred will be  
indicated successively for  
4 blinks each.

---

---

# Troubleshooting



---

## At a Glance

### What's in this Chapter

This chapter provides information on correcting problems with the drive and contains the following topics:

Topic	Page
Warning messages	94
Error messages	95
Troubleshooting	99

## Warning Messages

### Warning Identification and Description

A warning is generated when a non-fatal fault occurs. Non-fatal faults allow the drive to remain enabled and the fault relay contact to remain closed. Either of the programmable digital outputs can be programmed to indicate that a warning condition has been detected. The cause of the warning is presented as an alphanumeric code on the drive's front panel LED display; these warning codes are identified and described in the following table.

Warning Code	Designation	Explanation
n01	!t warning	Current threshold set by "I <sup>2</sup> t Message" parameter was exceeded.
n02	Regen power	Power threshold set by "Max Regen Power" parameter was exceeded.
n03	Following Fault	Following error threshold set by "Following Error" parameter was exceeded.
n04	Response monitoring	Response monitoring (fieldbus) is active
n05	Mains phase	Mains phase missing. Can be disabled for single phase operation with the "Mains Phase Missing" parameter.
n06	Sw limit-switch 1	Passed software limit-switch 1.
n07	Sw limit-switch 2	Passed software limit-switch 2.
n08	Motion task error	A faulty motion task was started.
n09	No "Home" reference point	Motion task started with no "Home" reference point set.
n10	Positive Limit	Positive limit-switch activated.
n11	Negative Limit	Negative limit-switch activated.
n12	Default values	Only HIPERFACE@: motor default values loaded.
n13	Expansion card	Expansion card not functioning correctly.
n14	HIPERFACE@-reference mode	Attempt to reset while HIPERFACE@-reference mode was active.
n15	Table error	Velocity current table INXMODE 35 error
n16	"OR" Warning	Is active, if one or more of the warnings n17 ... n31 are active.
n17	CAN-SYNC	CAN-Sync is not locked
n18	Moving overrun	Using Multiturn encoder feedback, a overrun over the maximum number of resolution (+/-2048) was detected (starting with firmware 4.91)
n19 ... n31	Reserved	reserved
n32	Firmware beta version	The firmware is not a released beta version
A	Reset	RESET is active at DIGITAL IN x

---

## Error Messages

---

### Error Identification and Description

Errors are generated when a fatal fault occurs. Fatal faults cause the drive to be disabled, the brake (if installed) to be activated and the fault relay contacts to open. Either of the programmable digital outputs can also be programmed to indicate that an error has been detected. The cause of the error is presented as an alphanumeric code on the drive's front panel LED display; these error codes are identified and described in the following table.

Error Code	Error (Fault)	Possible Cause/Corrective Action
F01*	Drive heat sink overtemperature.	<ul style="list-style-type: none"><li>- Improve ventilation.</li><li>- Reduce motion profile duty cycle.</li></ul>
F02*	DC link voltage limit exceeded.	<ul style="list-style-type: none"><li>- Check Parameter "Mains Supply Voltage" for correct setting.</li><li>- Supply voltage too high; use a mains transformer.</li><li>- Regen power limit was exceeded; adjust motion profile or install larger regen resistor.</li></ul>
F03*	Following error limit exceeded.	<ul style="list-style-type: none"><li>- Increase <math>I_{rms}</math> or <math>I_{peak}</math> (keep within motor operating range).</li><li>- SW ramp parameters set too large.</li></ul>
F04	Feedback signals missing or incorrect.	<ul style="list-style-type: none"><li>- Defective feedback device.</li><li>- Check for correct device type selected in "Feedback Type" parameter.</li><li>- Check feedback cable and connections.</li></ul>
F05*	DC-link voltage less than factory preset (100V).	Supply voltage not present or too low when drive was enabled. Only enable the drive when the mains supply voltage has been on longer than 500 ms.

*Continued on next page*

## Error Messages, continued

### Error Identification and Description, continued

Error Code	Error (Fault)	Possible Cause/Corrective Action
F06	Motor overtemperature.	<ul style="list-style-type: none"> <li>- <math>I_{rms}</math> or <math>I_{peak}</math> set too high.</li> <li>- Defective motor</li> <li>- If motor is not hot, check feedback cables and connectors.</li> <li>- Reduce motion profile duty cycle</li> <li>- Improve ventilation of the motor</li> </ul>
F07	Internal 24 Vdc fault.	Return drive to manufacturer
F08*	Motor speed limit exceeded.	<ul style="list-style-type: none"> <li>- Feedback parameters not set correctly.</li> <li>- Incorrect feedback wiring.</li> <li>- Motor phases reversed.</li> <li>- Check Parameter "Overspeed" for correct setting.</li> </ul>
F09	EEPROM checksum error.	Return drive to manufacturer.
F10	Flash-EPROM checksum error.	Return drive to manufacturer.
F11	Motor brake fault.	<ul style="list-style-type: none"> <li>- Brake parameter set to "WITH" when brake does not exist.</li> <li>- Defective brake.</li> <li>- Check motor power cable and connections.</li> </ul>
F12	Motor phase missing.	<ul style="list-style-type: none"> <li>- Defective motor.</li> <li>- Check motor power cable and connections</li> </ul>
F13*	Drive internal temperature exceeded.	<ul style="list-style-type: none"> <li>- Improve ventilation.</li> <li>- Reduce motion profile duty cycle.</li> </ul>

*Continued on next page*

## Error Messages, continued

### Error Identification and Description, continued

Error Code	Error (Fault)	Possible Cause/Corrective Action
F14	Drive output stage fault.	<ul style="list-style-type: none"> <li>- Check motor cable for damage or shorts.</li> <li>- Output module is overheated; improve ventilation.</li> <li>- Short-circuit or short to ground in the external Regen resistor.</li> <li>- Motor has short-circuit/ground short; replace motor.</li> <li>- Output stage is faulty; return drive to manufacturer.</li> </ul>
F15	I <sup>2</sup> t maximum value exceeded.	<ul style="list-style-type: none"> <li>- I<sub>rms</sub> or I<sub>peak</sub> set incorrectly.</li> <li>- Reduce motion profile duty cycle.</li> </ul>
F16*	Mains supply missing two or three phases.	<ul style="list-style-type: none"> <li>- Check mains fuses.</li> <li>- Check mains wiring and connections on drive.</li> </ul>
F17	A/D converter error.	Return drive to manufacturer
F18	Regen circuit faulty or incorrect setting.	<ul style="list-style-type: none"> <li>- Check wiring of external regen resistor if used.</li> <li>- Check fuses of external regen resistor.</li> </ul>
F19*	Mains supply missing one phase.	<ul style="list-style-type: none"> <li>- Single phase operation is forbidden. Phase missing parameter must not be "no message"</li> <li>- Check mains supply fuses.</li> <li>- Check mains connector on drive.</li> <li>- Check mains supply wiring.</li> </ul>
F20	Slot fault	Hardware fault of the expansion card

---

<b>Error Code</b>	<b>Error (Fault)</b>	<b>Possible Cause/Corrective Action</b>
F21	Handling fault	Software fault of the expansion card
F22	Short circuit to earth	Short circuit to earth
F23	CAN Bus off	CAN Bus total communication error
F24	Warning	Warning displays as error
F25	Commutation error	Encoder system only. Actual speed is incompatible with speed and acceleration parameters.
F26	Limit switch	Homing error (hardware limit switch reached)
F27	AS-option	Operating error for AS-option
F28	Reserved	Reserved
F29	SERCOS/networks	SERCOS error. Communication loss, - hardware disable is not valid - sharing of SERCOS/RS232 resources
F30	Emerg. Stop Timeout	Emerg. Stop Timeout
F31	Reserved	Reserved
F32	System error	System software not responding correctly, return drive to manufacturer.

\* = These error messages can be cancelled by the ASCII command CLRFAULT, without executing a reset. If only these errors are present, and the RESET button or the I/O-function RESET is used only, the CLRFAULT command will be carried out.

---

---

## Troubleshooting

---

### **Problems, Possible Causes and Corrective Actions**

The following table identifies some common system problems, their possible causes and recommended corrective actions. However, the configuration of your installation may create other reasons, and consequently other corrections, for the problem.

<b>Problem</b>	<b>Possible Causes</b>	<b>Corrective Actions</b>
No communication with PC	<ul style="list-style-type: none"><li>- Wrong cable used.</li><li>- Cable plugged into wrong position in drive or PC.</li><li>- Wrong PC interface selected.</li></ul>	<ul style="list-style-type: none"><li>- Check cable.</li><li>- Plug cable into the correct sockets on the drive and PC.</li><li>- Select correct interface.</li></ul>
Motor does not rotate	<ul style="list-style-type: none"><li>- Drive not enabled.</li><li>- Break in analog input cable.</li><li>- Motor phases swapped.</li><li>- Brake not released.</li><li>- Motor is mechanically blocked.</li><li>- Motor pole number set incorrectly.</li><li>- Feedback set up incorrectly.</li></ul>	<ul style="list-style-type: none"><li>- Apply enable signal</li><li>- Check cable</li><li>- Correct motor phase sequence</li><li>- Check brake control</li><li>- Check mechanism</li><li>- Set motor pole number.</li><li>- Set up feedback correctly.</li></ul>

---

*Continued on next page*

---

## Troubleshooting, continued

---

### Problems, Possible Causes and Corrective Actions, continued

Problem	Possible Causes	Corrective Actions
Motor oscillates	<ul style="list-style-type: none"><li>- Gain too high (speed controller).</li><li>- Shielding in feedback cable has a break.</li><li>- Analog Com not connected.</li></ul>	<ul style="list-style-type: none"><li>- Reduce Kp (speed controller).</li><li>- Replace feedback cable.</li><li>- Connect Analog Com to controller common.</li></ul>
Poor servo performance (drive too soft)	<ul style="list-style-type: none"><li>- Kp (speed controller) too low.</li><li>- Tn (speed controller) too high.</li><li>- PID-T2 too high.</li><li>- T-Tacho too high.</li></ul>	<ul style="list-style-type: none"><li>- Increase Kp (speed controller).</li><li>- Use motor default value for Tn (speed controller).</li><li>- Reduce PID-T2.</li><li>- Reduce T-Tacho.</li></ul>
Motor runs roughly	<ul style="list-style-type: none"><li>- Kp (speed controller) too high.</li><li>- Tn (speed controller) too low.</li><li>- PID-T2 too low.</li><li>- T-Tacho too low.</li></ul>	<ul style="list-style-type: none"><li>- Reduce Kp (speed controller).</li><li>- Use motor default value for Tn (speed controller).</li><li>- Increase PID-T2.</li><li>- Increase T-Tacho.</li></ul>

---

---

# Specifications

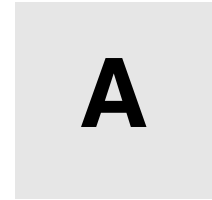

---

## At a Glance

### What's in this Appendix

This appendix contains the following topics.

Topic	Page
Performance specifications	102
Environmental and mechanical specifications	103
Electrical specifications	105
Wire specifications (recommended)	119

---

---

## Performance Specifications

---

### Performance Specifications Table

The following table lists 17D HP performance specifications.

PERFORMANCE		
Servo updates	Torque	62.5 $\mu$ sec
	Velocity	250 $\mu$ sec
	Position	250 $\mu$ sec
Tuning procedure	UniLink application*	
* Included in AM0 CSW 001V350 (CD-ROM)		

---

## Environmental and Mechanical Specifications

### Environmental Specifications Table

The following table provides 17D HP environmental specifications.

ENVIRONMENTAL		
Storage	High temperature, non-operating	+70°C maximum
	Low temperature, non-operating	-25°C minimum
Humidity	Non-operating	95% RH maximum, non-condensing
	Operating	85% RH maximum, non-condensing
Operating temperature (ambient measured at fan inlet)	Full power	0 ... 45°C
	With linear derating 2.5% / °C (available power: 75% of rated output at 55°C)	45 ... 55°C max
Vibration (operational)	10 ... 57 Hz	Sinusoidal, 0.75 mm amplitude
	57 ... 150 Hz	1.0 g
Air pressure	Operating:	
	Full power	1000 m (90 kPa)
	With linear derating 1.5% / 100m (available power: 75% of rated output at 2500m)	1000 ... 2500m (73kPa) max
	Transport	57 kPa (4540 m)
Contaminants	Pollution degree 2, as defined in EN60204/EN50178	
Cooling	Models: MHDA1112p00 MHDA1198p00	Forced convection by built-in fans

Continued on next page

---

## Environmental and Mechanical Specifications, continued

---

### Mechanical Specifications Table

The following table provides 17D HP mechanical specifications.

Rated data		MHDA1112p00	MHDA1198p00
Weight	Kg	19.5	21
Height without shield sheet, without eyes (with eyes)	mm	345 (375)	
Height with shield sheet, without eyes (with eyes)	mm	484 (495)	
Width	mm	250	
Depth without connectors	mm	300	
Depth with connectors	mm	325	

---

---

## Electrical Specifications

---

### What's in this Section

This section provides tables for the following topics.

Topic	Page
Electrical Specifications - Power	106
Electrical Specifications - Regen resistor	111
Electrical Specifications - Signal	112

---

---

## Electrical Specifications - Power

---

### Line Input Specifications Table

The following table provides 17D HP line input specifications.

LINE INPUT		
Voltage	208 Vac -10% 60 Hz, 230 Vac -10% 50 Hz. 480 Vac +10%, 50 ... 60 Hz, three-phase*	
Current	MHDA1112p00	48 A
	MHDA 1198p00	84 A
Inrush current	Internally limited	
* Read carefully "Electrical considerations"		

---

*Continued on next page*

## Electrical Specifications - Power, continued

### Bias Input Specifications Table

The following table provides 17D HP bias input specifications.

Motor Brake Present	Bias Input	Value
No	Voltage	24V -5% +15%
	Current	2 A
Yes	Voltage	*
	Current	2 A + I brake
* See the following table		



**Note:** The bias input also provides power to the optional motor brake.

### Limit supply values of the servodrive MHDA associated with a BPH motor brake

To take into account voltage drops caused by the Lexium MHDA servodrive and AGO FRU/AGO KIT supply cable connecting the servodrive to the motor, it is essential that the servodrive power connection supply the holding brake with a compatible voltage.

#### Voltage range of servodrive power supply c V (1)

Power supply cable length							
Model	5 m	10 m	15 m	25 m	40 m	50 m	75 m
BPH190p with brake	23,6...26,8	24...27	24,3...27,2	25...27,6	26...27,6	26,6...27,6	impossible (2)

(1) Voltage measured on the X4 connector of the MHDA servodrive

(2) A relay between brake and drive is necessary.

### External Fuse Specifications Table

The following table provides 17D HP external fuse specifications.

Input Type	Model Number	Fuse
Line	MHDA1112p00	50 A, aM
	MHDA1198p00	80 A, aM
External Regen	MHDA1112p00	16 A, fast acting* (DF2-CN16)
	MHDA1198p00	20 A, fast acting*(DF2-CN20)
*Two fuses in series, >= 500 V, dimensions: 10 x 38		

---

*Continued on next page*

---

## Electrical Specifications - Power, continued

---

### Motor Output Specifications Table

The following table provides 17D HP motor output specifications.

Parameter	Type	Model Number	Current
Output current (RMS)	Continuous (I <sub>rms</sub> )	MHDA1112p00	40 A
		MHDA1198p00	70 A
	Intermittent* (I <sub>peak</sub> )	MHDA1112p00	80 A
		MHDA1198p00	140 A
Switching frequency	8 kHz ± 0.1%		
Cable length	75 m max		
Maximum cable capacitance (motor phase to ground or shield)	< 250 pF/m		
* Duration depends on settings in Unilink			
$T_{I_2T} = \frac{I_{rms}^2 \times 15s}{I_{peak}^2 - I_{rms}^2}$			

Motors must be compatible with following table.

Model	Inductance Min. (mH)		
	480V - 8 kHz	230V - 8 kHz	230V - 16 kHz
MHDA1112p00	0.75	0.4	0.2
MHDA1198p00	0.38	0.2	0.1

---

---

## Electrical Specifications - Power, continued

---

### Internal Power Dissipation Specifications Table

The following table provides 17D HP internal power dissipation at maximum continuous output power. This information may be useful to size the thermal capability of the mounting cabinet.

Model Number	Power
MHDA1112p00	400 W
MHDA1198p00	700 W



**Note:** These power dissipations are measured at maximum continuous power and should be considered worst case. Often in sizing servo systems, factors such as profile duty cycle may reduce these numbers. These values do not include power dissipated in the Regen resistor. This is application-specific and must be calculated separately.

Quiescent dissipation when output stage is disabled is 40 W

---

## Electrical Specifications - Regen Resistor

### Regen Circuit Specifications

The following table provides technical data on the Regen circuit.

Parameter		Rated data	Units	Model Number	
				MHDA	
				1112p00	1198p00
Supply Voltage	3 phase, 230 V	Upper switch-on level of Regen circuit	V	400 - 430	
		Switch-off level of Regen circuit	V	380 - 410	
		Overvoltage F02	V	450	
		Continuous power of Regen circuit (RBext) max.	kW	6	
		Pulse power, external (RBext max. 1s)	kW	10	16
	3 phase, 400 V	Upper switch-on level of Regen circuit	V	720 - 750	
		Switch-off level of Regen circuit	V	680 - 710	
		Overvoltage F02	V	800	
		Continuous power of Regen circuit (RBext) max.	kW	6	
		Pulse power, external (RBext max. 1s)	kW	35	50
	3 phase, 480 V	Upper switch-on level of Regen circuit	V	840 - 870	
		Switch-off level of Regen circuit	V	800 - 830	
		Overvoltage F02	V	900	
		Continuous power of Regen circuit (RBext) max.	kW	6	
		Pulse power, external (RBext maximum 1s)	kW	45	70
External Regen resistor			Ω	15	10

---

## Electrical Specifications - Signal

---

### Motor Overtemperature Input Specifications Table

The following table provides 17D HP motor overtemperature input specifications.

MOTOR OVERTEMPERATURE INPUT	
Thermistor	PTC, will generate fault when resistance exceeds $290\Omega \pm 10\%$ (default value)*
Thermostat	Closed for normal operation
*The value of the threshold is adjustable by the parameter MAXTEMPM (see Unilink commands)	

---

### Resolver Input Specifications Table

The following table provides resolver input specifications.

RESOLVER	
Reference	8kHz $\pm$ 0.1%
Drive capability	35 mA RMS max.
Amplitude	4.75V RMS
Resolution	14 bits (0.02°)
Accuracy	12 bits (0.09°)
Conversion method	Tracking
Resolver type	Transmit mode
Resolver transformation ratio	0.5
Loss of feedback	Detection circuit included
Maximum cable length	75 m
Maximum cable capacitance (signal connector to shield)	120 pF/m
Pair of poles	1 (default)

---

*Continued on next page*

## Electrical Specifications - Signal, continued

### Encoder Input Specifications Table

The following table provides 17D HP encoder input specifications

ENCODER INPUT				
Internal power supply	Voltage	9V $\pm$ 5%		
	Current (maximum)	200 mA		
Input Signal	Sin-Cos encoder (cyclic absolute)	Absolute accuracy	15 bits (39 arc-seconds or 0.01°)	
		Resolution	20 bits (1.2 arc-seconds or 0.0003°)	
	Sin-Cos encoder (multi-turn absolute)	Turn counter	12 bits	
		Absolute accuracy within one turn	15 bits (39 arc-seconds or 0.01°)	
		Resolution within one turn	20 bits (1.2 arc-seconds or 0.0003°)	

### Emulated Encoder Output (Incremental Format) Specifications Table

The following table provides 17D HP emulated encoder output (in incremental format) specifications.

EMULATED ENCODER OUTPUT (INCREMENTAL FORMAT)	
Channels	A, B, and Marker
Type	Differential, RS-485 compliant
Resolution with:	Resolution:
Resolver feedback	16...1024
Sin-Cos Encoder feedback	16...4096 and 8192...524288 (2 <sup>n</sup> )

*Continued on next page*

## Electrical Specifications - Signal, continued

### Encoder Output (Incremental Format) Timing Diagram

The following diagram shows the timing for the encoder output (incremental format).

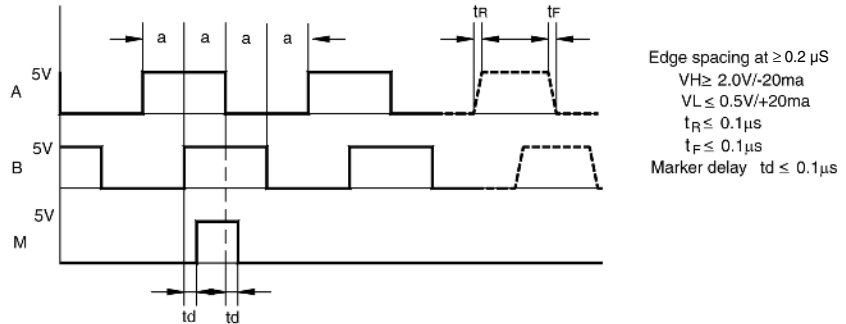

### Encoder Output (SSI Format) Specifications Table

The following two tables provide 17D HP encoder output (in SSI format) specifications

ENCODER OUTPUT (SSI FORMAT) - ELECTRICAL	
Channels	Data and Clock
Type	Differential, RS-485 compliant

ENCODER OUTPUT - SSI FORMATTING	
Primary Feedback Type	Possible Emulations
Resolver	Single-turn SSI - 12 upper bits set to 0, 12 lower bits for position within one turn. Configurable for Gray or binary code.
Sin-Cos (single-turn)	
Sin-Cos	Single-turn SSI - 12 upper bits set to 0, 12 lower bits for position within one turn (SSIMODE 0). Configurable for Gray or binary code.
	Multi-turn SSI - 12 upper bits for turns count, 12 lower bits for position within one turn (SSIMODE 1). Configurable for Gray or binary code.

*Continued on next page*

---

## Electrical Specifications - Signal, continued

---

### Encoder Input (Slave) Specifications Table

The following table provides 17D HP encoder input (slave) specifications.

ENCODER INPUT (SLAVE)	
Channels	A and B
Type	Differential, RS-485 compliant
Voltage	8 V nominal
Current	200 mA (maximum)
Maximum frequency	1.5 MHz
Rise time	$\leq 0.1 \mu\text{s}$
Fall time	$\leq 0.1 \mu\text{s}$

---

### Discrete Input Specifications Table

The following table provides 17D HP discrete input specifications.

DISCRETE INPUT	
Channels	Five (four programmable and one dedicated for enable)
Type	Solid state, optically isolated, compatible IEC 1131-2 type 1
Transient isolation voltage	250 Vac (channel to chassis)
$V_{IN}$ maximum	30 Vdc
$I_{IN}$ @ $V_{IN} = 24 \text{ V}$	5 mA
$V_{IH}$ minimum	12 V (minimum input voltage to be recognized as high – true)
$V_{IL}$ maximum	7 V (maximum input voltage to be recognized as low – false)
Scan time:	
Normal	1 ms
High speed	$< 50 \mu\text{sec}$

---

*Continued on next page*

---

## Electrical Specifications - Signal, continued

---

### Discrete Output Specifications Table

The following table provides 17D HP discrete output specifications.

DISCRETE OUTPUT	
Channels	Two
Type	Solid state: open collector 30Vdc max, optically isolated
Transient isolation voltage	250 Vac (channel to chassis)
Sense	True low, sinking
$I_{OUT}$	10 mA maximum
Protection	Yes (PTC resistor: 25 $\Omega$ )
Scan time	1 ms

---

### Fault Relay Output Specifications Table

The following table provides 17D HP fault relay output specifications.

FAULT RELAY OUTPUT	
Type	Relay contact
Sense	True (open)
$V_{MAX}$	36 Vdc; 42 Vac
$I_{OUT}$	500 mA resistive

---

### Brake Output Specifications Table

The following table provides 17D HP brake output specifications.

BRAKE OUTPUT	
$V_{OUT}$	Internally connected to bias supply 24 Vdc
$I_{OUT}$	3 A (maximum)



**Note:** An external brake relay is required for cable lengths greater than 50 m.

---

*Continued on next page*

---

## Electrical Specifications - Signal, continued

---

### Analog Input Specifications Table

The following table lists the analog inputs specifications.

ANALOG INPUTS	
Channels	Two
Type	Differential, non-isolated
Maximum common mode voltage referenced to AGND	$\pm 10\text{V}$
Measurement range	$\pm 10\text{ Vdc}$
Maximum differential input	$\pm 12\text{ V}$
Accuracy	12 bit
Resolution	Input 1 = 14 bits ( $\pm 10\text{V}$ range) Input 2 = 12 bits ( $\pm 10\text{V}$ range)
Input impedance	20 k $\Omega$
Scan time	250 $\mu\text{s}$

---

### Analog Output Specifications Table

The following table lists the analog output specifications.

ANALOG OUTPUTS	
Channels	Two
Type	Single-ended, non-isolated referenced to AGND
$V_{\text{OUT}}$	$\pm 10\text{ V}$
$I_{\text{OUT}}$	$\pm 5\text{ mA}$
Output impedance	2.2 k $\Omega$
Maximum load capacitance	0.1 $\mu\text{F}$
Resolution	10 bit
Update time	5 msec

---

*Continued on next page*

---

## Electrical Specifications - Signal, continued

---

### Serial Communications Specifications Table

The following table lists the serial communications specifications.

SERIAL I/O	
Data bit	Eight
Stop bit	One
Parity	None
Baud rate	9600

---

## Wire Specifications (Recommended)

### Wire Specifications

The following table lists the recommended wire specifications. Use only copper wire with insulation rated at 75°C or greater, unless otherwise specified.

Item	Drive Model No.	Wire Size	Notes
AC mains	MHDA1112p00	16 mm <sup>2</sup> or 5 AWG	600V, 105°C
	MHDA1198p00	25 mm <sup>2</sup> or 3 AWG	
Protective earth	All 17D HP	25 mm <sup>2</sup> or 3 AWG	
DC Link	MHDA1112p00	16 mm <sup>2</sup> or 5 AWG	Shielded for lengths greater than 20cm 1000V , 105°C
	MHDA1198p00	25 mm <sup>2</sup> or 3 AWG	
Analog signals	All 17D HP	0.25 mm <sup>2</sup> or 22 AWG minimum	Twisted pairs, shielded
Digital I/O and Fault Relay	All 17D HP	0.5 mm <sup>2</sup> or 20 AWG minimum	
Brake	All 17D HP	1.0 mm <sup>2</sup> or 18 AWG minimum	Shielded
Bias power 24 Vdc	All 17D HP	2.5 mm <sup>2</sup> or 14 AWG maximum	check voltage drop
External Regen resistor	All 17D HP	10 mm <sup>2</sup> or 6 AWG (see p, 49)	High temperature insulation 1000V, 105°C or greater

---

---

## Parts List



# B

---

### At a Glance

#### What's in this Appendix

This appendix contains information about the following Lexium 17D HP parts and assemblies.

Topic	Page
Lexium 17D HP drives	122
Mains choke	123
External 24VDC supply	124
Drive cables	125
Optional external Regen resistor assemblies	126
Optional Mains filters	127
Spare parts	128

---

---

## Lexium 17D HP Drives

---

**Drives Available** The Lexium 17D HP drives are available in two models according to different output current levels as identified in the following table.

<b>Model</b>	<b>Intermittent (Peak) Output Current</b>	<b>Intermittent (RMS) Output Current</b>	<b>Continuous (RMS) Output Current</b>
MHDA1112*00	112.0 A	80.0 A	40.0 A
MHDA1198*00	198.0 A	140.0 A	70.0 A

---

---

## Mains choke

---

### Mains choke

External Mains choke is required and mandatory.

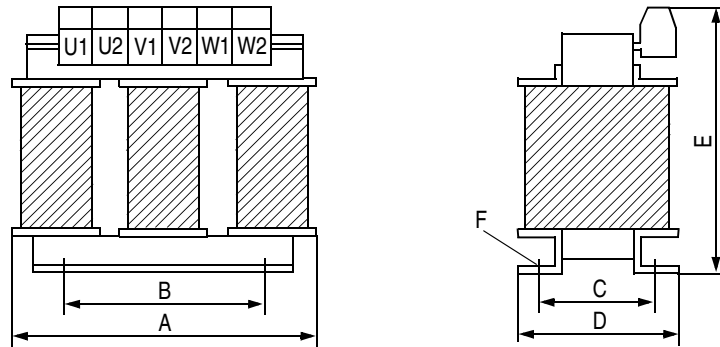

Type		Dimensions in mm						Weight	Current
	Phase	A	B	C	D	E	F	kg	A
AM0CHK170	3	190	170	58	110	255	Ø8	9	60
AM0CHK212	3	190	170	68	120	255	Ø8	10	75



**NOTE:** It must be installed very close to the drive.

---

---

## External 24VDC supply

---

### External 24VDC supply

	Output voltage	Rating	Parallel connection	Reference
	<b>V</b>	<b>A</b>		
<b>Module ~ 100...120V and ~ 200...240V, 50/60 - 400 Hz</b>	24 Vdc SELV	2.2	Yes	<b>TSX SUP 1021</b> (1) (2)
		5	Yes	<b>TSX SUP 1051</b> (1) (2)
<b>Unit ~ 100...120V and ~ 200...240V, 50/60 - 400 Hz</b>	24 Vdc SELV	10	Yes	<b>TSX SUP 1101</b> (1)

(1) Product supplied as standard with a bilingual reference guide: French and English.

(2) Mounted in Premium TSX RKY 6/8/12/6E/8E/12E racks (any slot except the slot for TSX PSY●●0M power supply modules), on AM1-DE200/DP200 rails or on AM1-PA mounting plate.

---

---

## Drive Cables

---

### Drive to Motor Cables

Consult the BPH motors manual for drive-to-motor cable part numbers and motor part numbers.

---

### RS-232 Serial Communications Cable Part Table

To connect the drive's serial interface port to your PC, use the following cable.

Part Number	Description
AM0CAV001V003	3 m cable

---

### Encoder Output Cable Parts Table

The following table lists encoder output cables for the Lexium 17D HP drive.

Part Number	Description
TSXCXP235	2 m 17D HP to CAY, incremental format
TSXCXP635	6 m 17D HP to CAY, incremental format
TSXCXP245	2 m 17D HP to CAY, SSI format
TSXCXP645	6 m 17D HP to CAY, SSI format
690MCI00206	6 m 17D HP to Quantum breakout module, tinned leads

---

*Continued on next page*

## Optional External Regen Resistor Assemblies

### Optional Regen Resistor Assembly Part Table

The following table identifies the optional external Regen resistor assemblies available for the Lexium 17D HP drive.

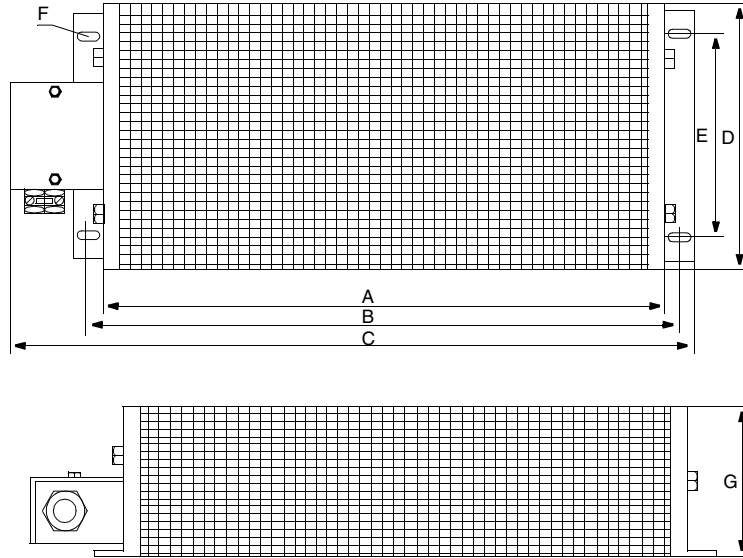

Regen Resistor Assembly Part Number	R	Power	A	B	C	D	E	F	G	Weight
	$\Omega$	W	mm	mm	mm	mm	mm	mm	mm	kg
AM0RFE002V086	15	860	300	326	386	92	64	6,5X12	120	3,5
AM0RFE002V160	10	1600	500	526	570	182	150	5,5X8	130	8,0

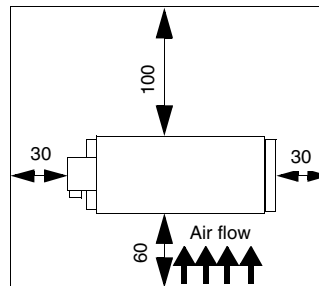
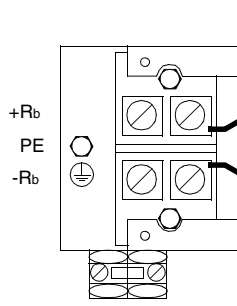

## Optional Mains filters

### Optional Mains filters

External interference suppression filter between Mains supply network and drive is required for class A.

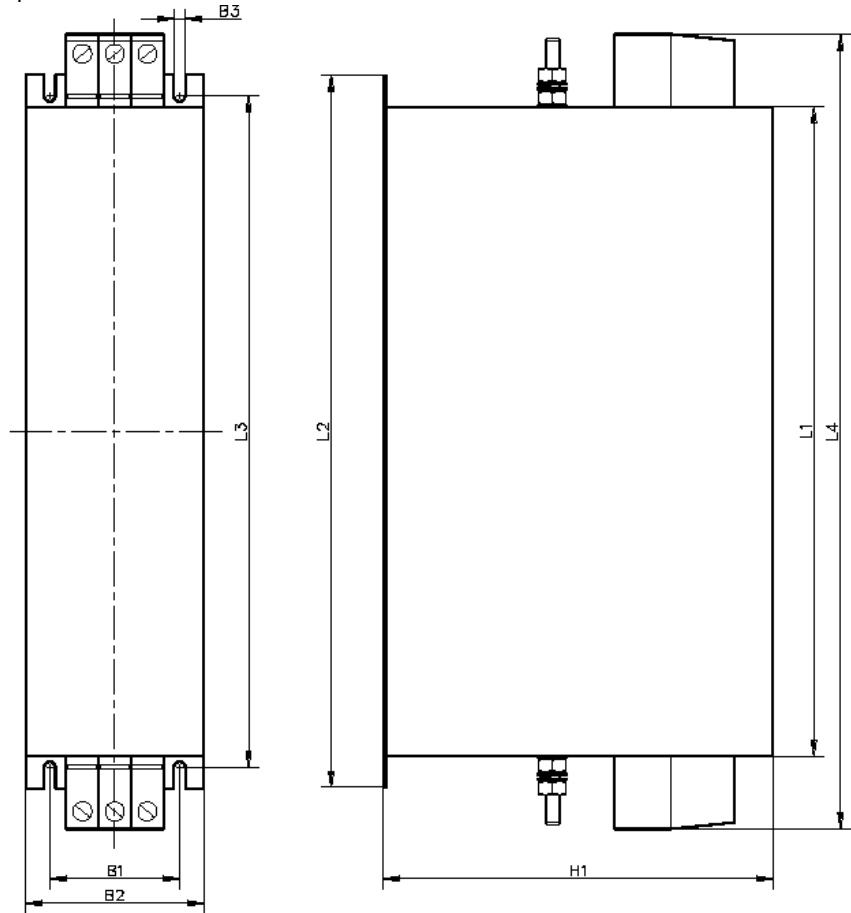

	Nom. current	L1	L2	L3	L4	B1	B2	B3	H1	Terminals	Bolts
Type	A	mm	mm	mm	mm	mm	mm	mm	mm	mm <sup>2</sup>	mm
AM0EMC118	42	305	335	320	355	35	60	7	150	10	5
AM0EMC212	75	300	330	314	380	55	80	7	185	25	6

---

## Spare Parts

---

### Spare Parts Table

These field-replaceable spare parts are available from Schneider.

Part Number	Description
AM0SPA002V001	17D HP Connector Kit: I/O connector 24 Vdc connector AS function connector

---

---

# Drive-to-Controller Wiring Diagrams

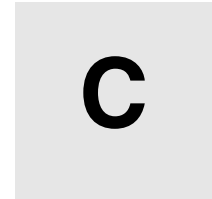

---

## At a Glance

### What's in this Appendix

This appendix provides diagrams that show you how to wire the signal connections between the Lexium 17D HP drive and all the Schneider closed-loop positioning modules that support it:

- Typical motion controller interface connections
- Modicon MOT 201 compact motion module
- Modicon Quantum Automation Series 140 MSx 101 00 motion modules
- Modicon B885-11x motion modules
- Premium CAY motion modules

This appendix presents the following topics:

Topic	Page
Typical motion controller interface connections	130
Wiring a 17D HP drive to Premium CAY motion modules	131
Wiring a 17D HP drive to a MOT 201 motion module	134
Wiring a 17D HP drive to Quantum 140 MSx motion modules	137
Wiring a 17D HP drive to B885-11x motion modules	138

## Typical Motion Controller Interface Connections

### Motion Controller Interface Diagram

The following diagram shows the connections between the 17D HP drive and a typical motion controller. (Refer to the list of pre-programmed functions contained in the UniLink online help.)

 **Note:** The Analog Com must always be be connected to the Controller Com as a ground reference.

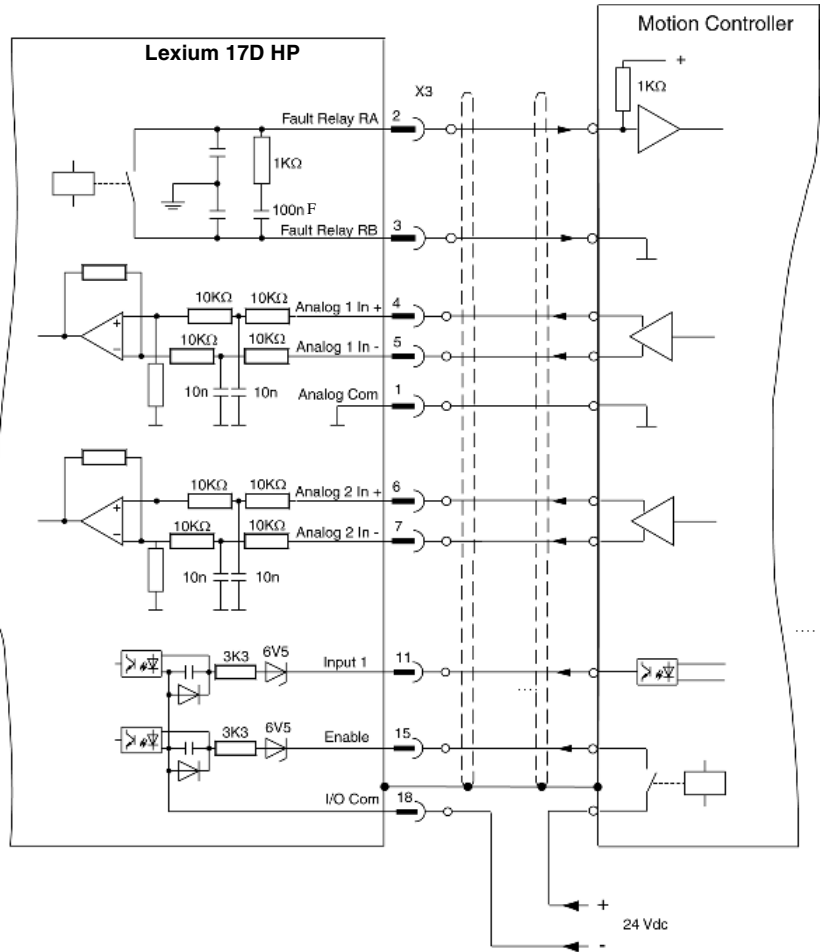

## Wiring a 17D HP Drive to Premium CAY Motion Modules

### Premium CAY Single Axis Drive Option Diagram

The following diagram shows wiring between a Premium CAY motion module and the X3 connector on a single Lexium 17D HP axis.

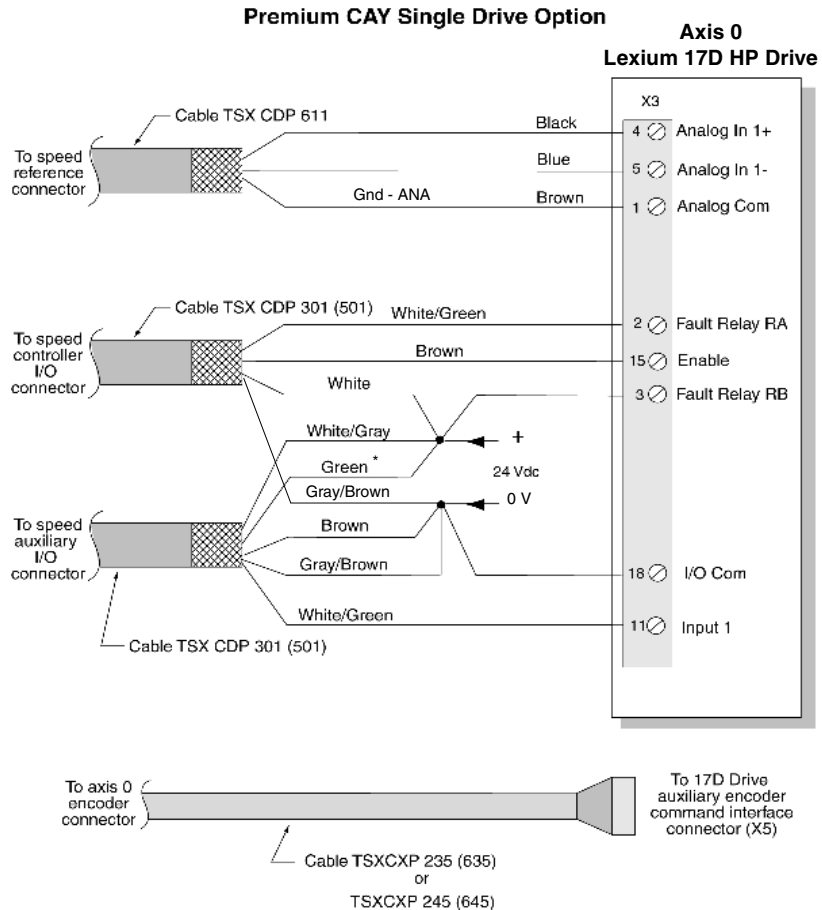

\* the encoder is powered by a 24 Vdc power supply

*Continued on next page*

## Wiring a 17D HP Drive to Premium CAY Motion Modules, continued

### Premium CAY Multi-Axis Breakout Module Wiring Diagram

The following diagram shows how the TAP MAS breakout module facilitates wiring between a Premium CAY multi-axis motion module and the Lexium 17D HP Analog I/O connector. This represents the first of four axes. It also shows wiring from the motion module to the Lexium 17D HP auxiliary encoder command interface connectors (X5) for four axes.

### Premium CAY Multi-Axis Motion Module and Breakout Module for Four 17D HP Axes

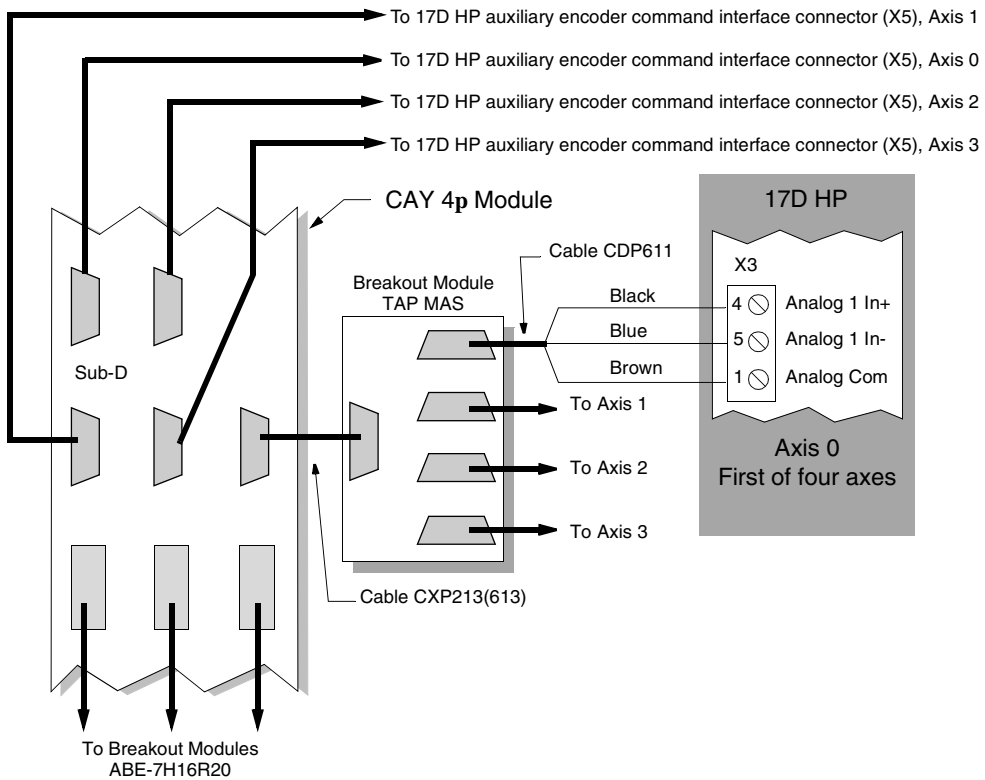

*Continued on next page*

## Wiring a 17D HP Drive to Premium CAY Motion Modules, continued

### Premium CAY Multi-Axis and Breakout Module Diagram, First of Four Axes

The following diagram shows how breakout module ABE-7H16R20 facilitates wiring from the Premium CAY multi-axis motion module and the Lexium 17D HP X3 connector. This represents the first of four axes.

### Premium CAY Multi-axis Breakout Modules Wiring, First of Four Axes

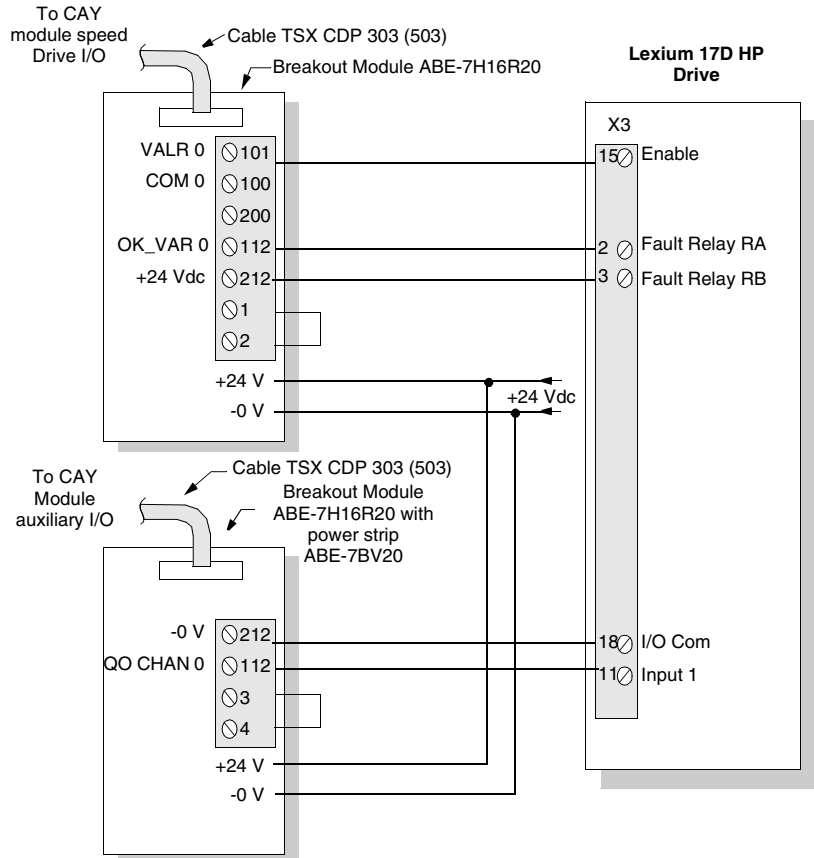

## Wiring a 17D HP Drive to a MOT 201 Motion Module

### MOT 201 Control Wiring Diagram

The following diagram shows the wiring between the MOT 201 connectors J3 and J1 and the Lexium 17D HP drive X3 connector as well as the 24 Vdc bias field power connection.

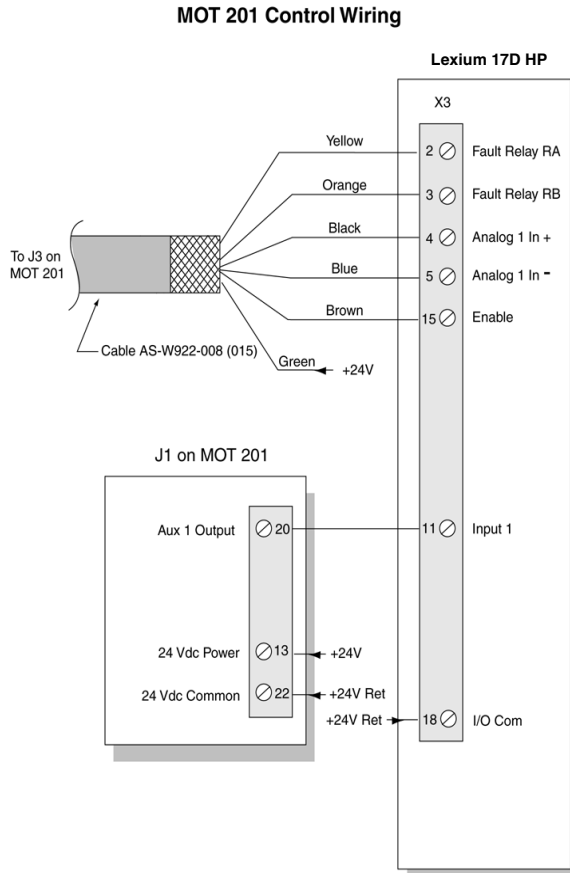

*Continued on next page*

---

## Wiring a 17D HP Drive to a MOT 201 Motion Module, continued

---

### MOT 201 Encoder Wiring Diagram: Option 1

The following diagram shows the wiring between the MOT 201 connector J4 and the Lexium 17D HP drive and the auxiliary encoder command Interface connector (X5).

#### MOT 201 Encoder Wiring Option 1

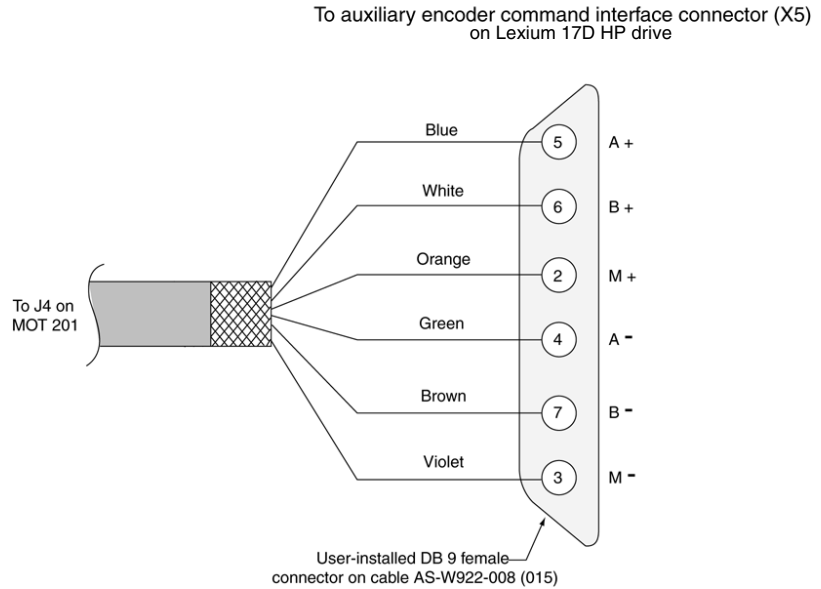

*Continued on next page*

---

## Wiring a 17D HP Drive to a MOT 201 Motion Module, continued

---

### MOT 201 Encoder Wiring Diagram: Option 2

The following diagram shows how the AS-BR85-110 breakout module facilitates encoder wiring between a MOT 201 motion module and an Lexium 17D HP drive. At one end, the MOT J5 and J4 connectors are plugged into the breakout module P3 connector. At the other end, the breakout module P1 connector is wired to the drive's auxiliary encoder command Interface connector.

#### MOT 201 Encoder Wiring Option 2

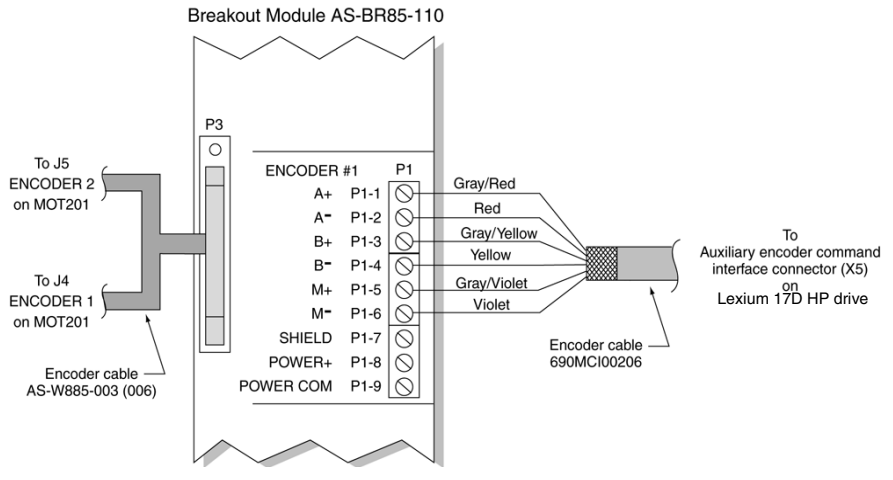

## Wiring a 17D HP Drive to Quantum 140 MSx Motion Modules

### Quantum 140 MSx Control and Encoder Wiring Diagram

The following diagram shows how a Quantum 140 MSx breakout module facilitates control and encoder wiring between a Quantum 140 MSx 101 00 motion module and an Lexium 17D HP drive.

Quantum 140 MSx 101 00 Control and Encoder Wiring

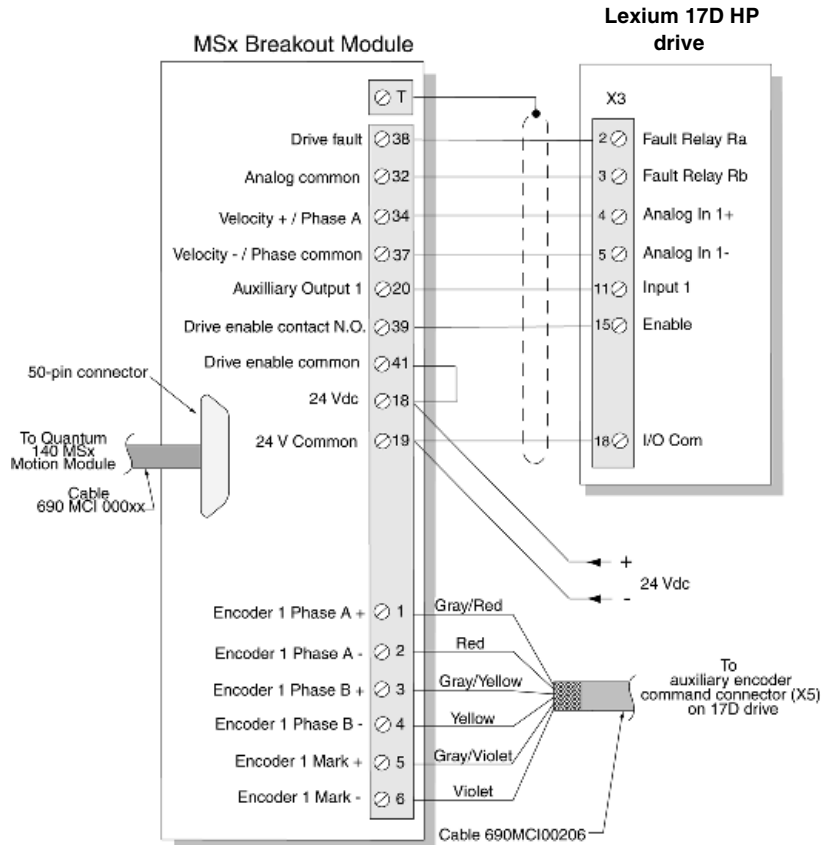

---

## Wiring a 17D HP Drive to B885-11x Motion Modules

---

### B885-11x Control Wiring Diagram

The following diagram shows the wiring between a B885-11x motion module connectors TB1 and TB3 to the Lexium 17D HP drive X3 connector.

### B885-11x Control Wiring

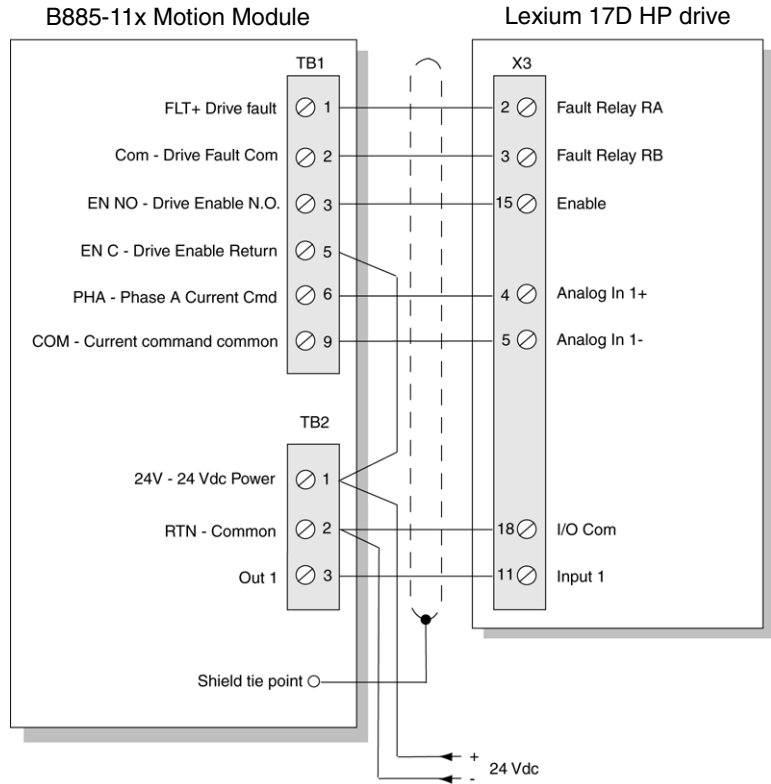

*Continued on next page*

---

## Wiring a 17D HP Drive to B885-11x Motion Modules, continued

---

**B885-11x  
Encoder Wiring  
Diagram:  
Option 1**

The following diagram shows the encoder wiring between the B885-11x motion module DB-25 connector and the Lexium 17D HP drive auxiliary encoder command interface connector (X5).

**B885-11x Encoder Wiring Option 1**

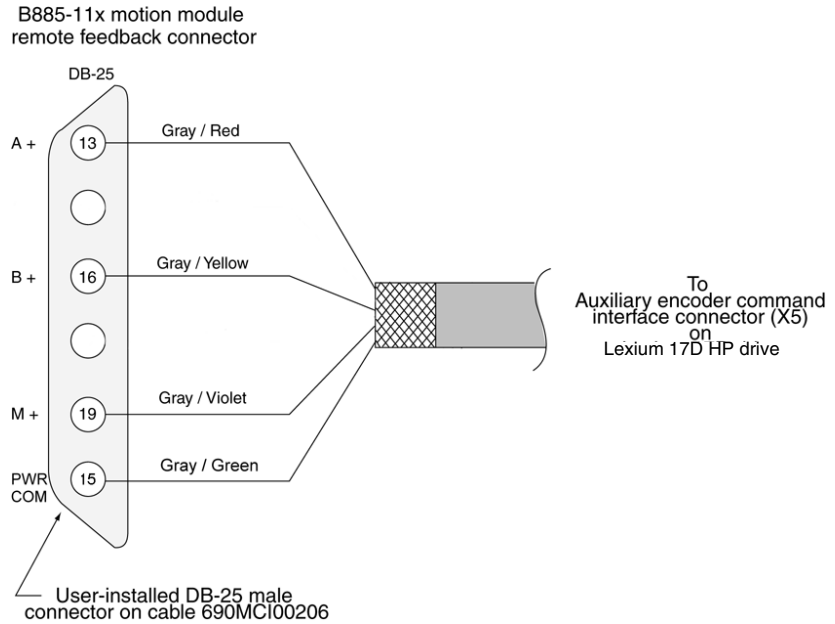

*Continued on next page*

---

## Wiring a 17D HP Drive to B885-11x Motion Modules, continued

---

### B885-11x Encoder Wiring Diagram: Option 2

The following diagram shows how the AS-BR85-110 breakout module facilitates encoder wiring between a B885-11x motion module and an Lexium 17D HP drive.

**B885-11x Encoder Wiring Option 2**

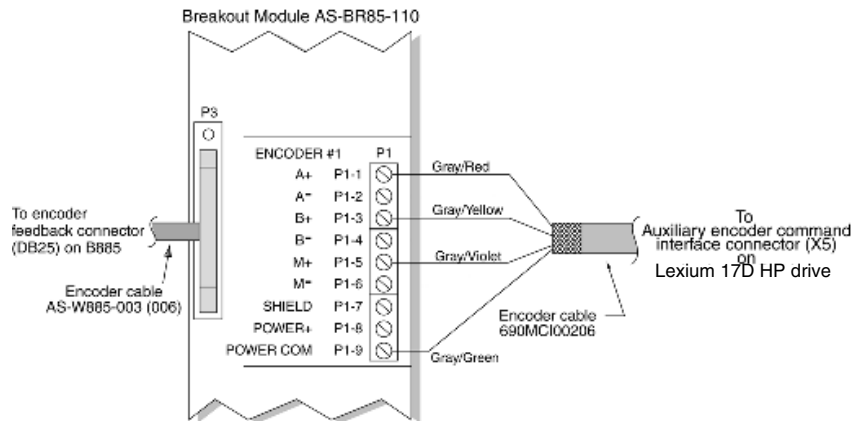

---

# Cable Connection Wiring Diagrams

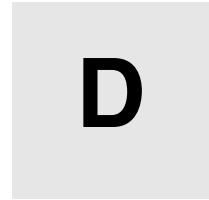

---

## At a Glance

### What's in this Appendix

This appendix provides procedures and diagrams that show you how to wire certain cable connectors that are used with the Lexium 17D HP drive.

This appendix presents the following topics.

Topic	Page
Wiring the Motor Power Connector (drive side)	142
Wiring a Sub-D connector with shielding	143
Wiring the feedback connector of the motors	145
Serial communications interface connector (X6) RS 232	146

---

# Wiring the Motor Power Connector (drive side)

## Motor Power Connector (Drive end) Diagram

The following diagram shows how to wire the motor power connector.

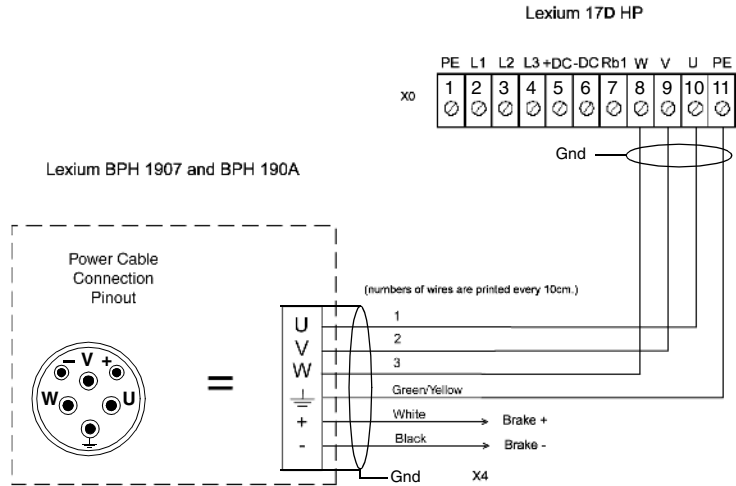

---

## Wiring a Sub-D Connector with Shielding

---

### Wiring the Sub-D Connector

If you construct your own Sub-D connector with shielding, please do so according to the following procedure which correlates to the eight steps in the diagram that follows this procedure.

Step	Action
1	Carefully remove about 25mm of the outer covering while taking care not to damage the braided shield.
2	Push the exposed braided shield back over the outer covering.
3	Leave the first 12mm of the braided shield free and insulate the rear portion with shrink tubing.
4	Carefully strip about 5mm from the individual wires while taking care not to damage the copper strands.
5	Verify pin assignments then solder the individual wires to the solder cups of the Sub-D connector. (Check the wire colors.) *
6	Attach the cable to the connector housing strain relief; the strain relief must have good contact with the exposed shielding of the cable.
7	Place the knurled screws in position.
8	Place the Sub-D connector in the groove of the half-housing (pin 1 at bottom) and press the two halves together.  <b>Note:</b> Once the halves of the housing have been pressed together, they cannot be opened without damaging them.



### Warning !

\* If the SubD connector housing is made of metallized plastic or is not metallic, solder a short wire between the cable shield and the metallic part of the SubD (Gnd).

---

## Wiring a Sub-D Connector with Shielding, continued

---

### Sub-D Connector Diagram

The following diagram shows the eight steps required to wire a Sub-D connector with shielding.

#### Wiring a Sub-D Connector with Shielding

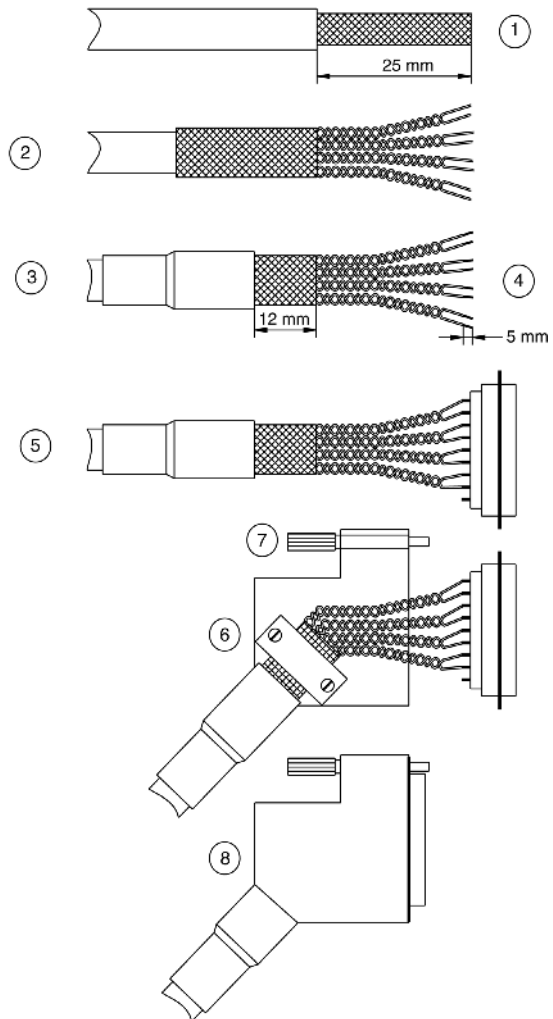

## Wiring the feedback connector of the motors

### Wiring the feedback connector of the BPH motors

Resolver.

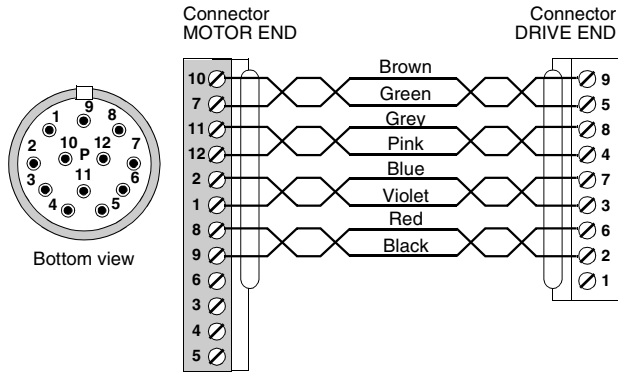

SINCOS encoder.

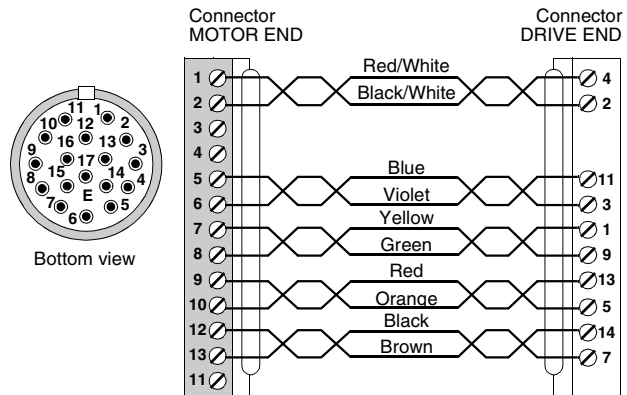

---

## Serial Communication Interface Connection (X6) RS 232

---

### Serial Communication Interface Cable Connectors

The following diagram details the connection between the drive and a PC.

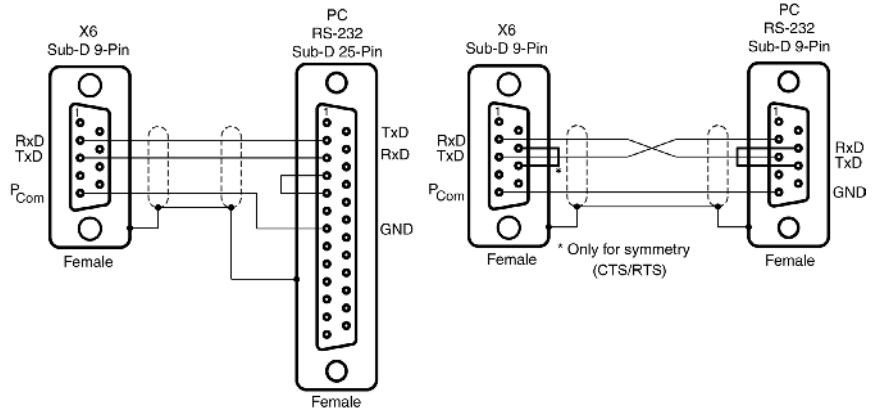

---

# Servo Loop Diagrams



---

## At a Glance

### What's in this Appendix

This appendix illustrates several servo loops within a 17D HP single-axis system.

Topic	Page
17D HP current controller overview	148
17D HP velocity controller loop	149
17D HP analog input loop diagrams	150

---

---

## 17D HP Current Controller Overview

---

### 17D HP Current Controller Diagram

The following diagram shows an overview of the 17D HP current controller servo loop.

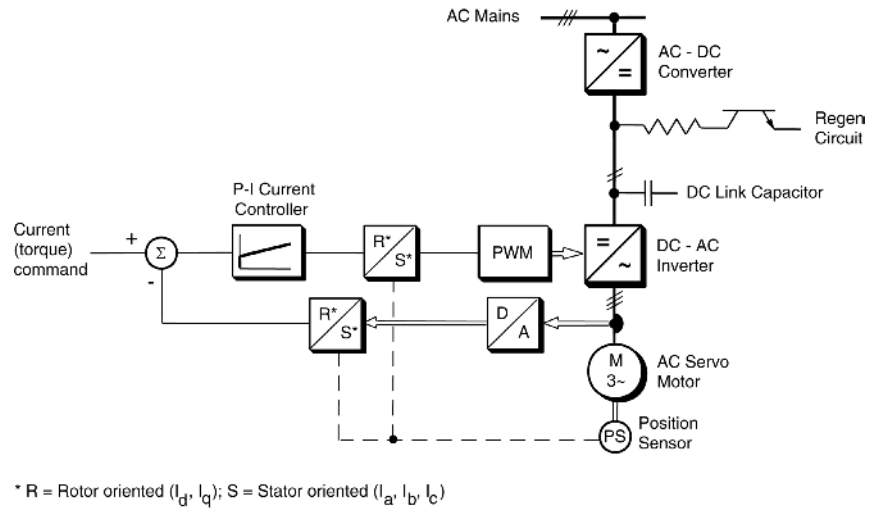

---

## 17D HP Velocity Controller Loop

---

### 17D HP Velocity Controller Loop Diagram

The following diagram shows a 17D HP velocity controller servo loop.

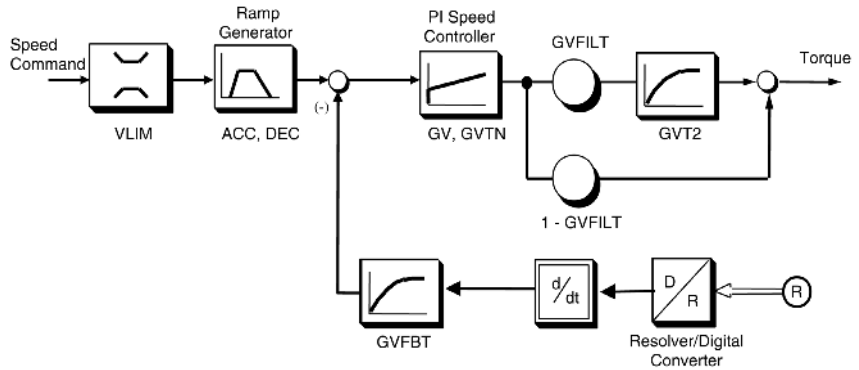

**Note:** Parameter designations correlate to terms used in the UniLink software.

---

---

## 17D HP Analog Input Loop Diagrams

---

### Overview

The following illustrations show simplified servo loops for analog input Modes 0, 1, 3, 4 and 5.

---

### 17D HP Analog Input Mode 0 Loop Diagram

The following diagram shows an 17D HP analog input Mode 0 servo loop.

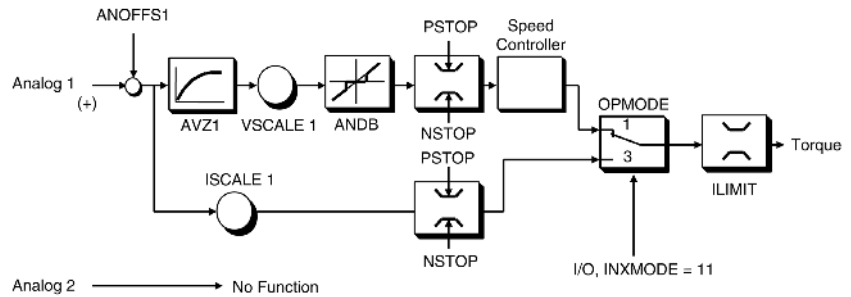

Standard Configuration

Velocity/Current Command via Analog 1

Analog 2 no Function

Selectable by OPMODE or Input

**Note:** Parameter designations correlate to terms used in the UniLink software.

---

*Continued on next page*

## 17D HP Analog Input Loop Diagrams, continued

### 17D HP Analog Input Mode 1 Loop Diagram

The following diagram shows an analog input Mode 1 servo loop.

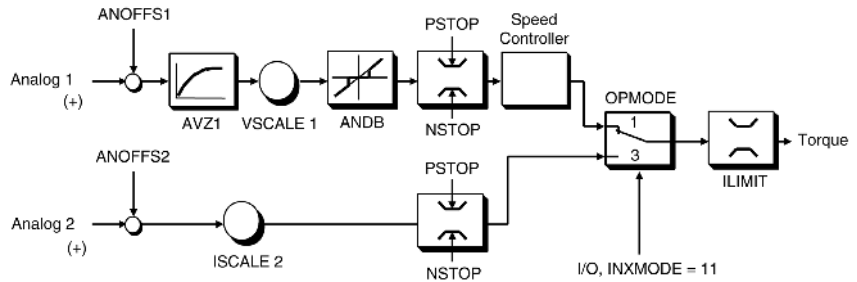

$V_{\text{command}} = \text{Analog 1}$ ,  $I_{\text{command}} = \text{Analog 2}$

Velocity Command via Analog 1

Current Command via Analog 2

Selectable by OPMODE or Input

**Note:** Parameter designations correlate to terms used in the UniLink software.

*Continued on next page*

## 17D HP Analog Input Loop Diagrams, continued

### 17D HP Analog Input Mode 3 Loop Diagram

The following diagram shows an analog input Mode 3 servo loop.

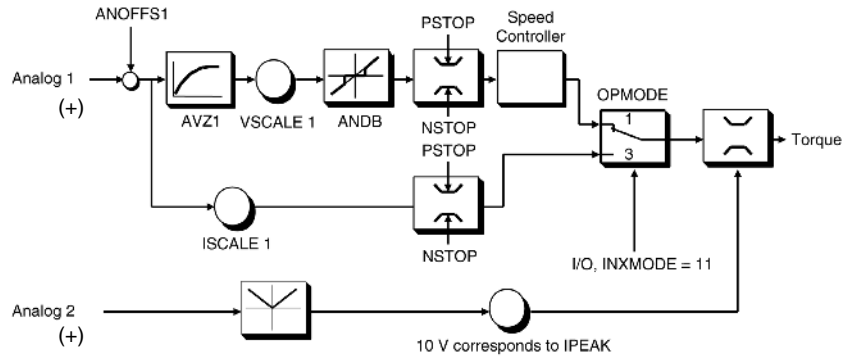

$$X_{\text{command}} = \text{Analog 1}, \quad I_{\text{limit}} = |\text{Analog 2}|$$

Selectable by OPMODE or Input

**Note:** Parameter designations correlate to terms used in the UniLink software.

*Continued on next page*

## 17D HP Analog Input Loop Diagrams, continued

### 17D HP Analog Input Mode 4 Loop Diagram

The following diagram shows an analog input Mode 4 servo loop.

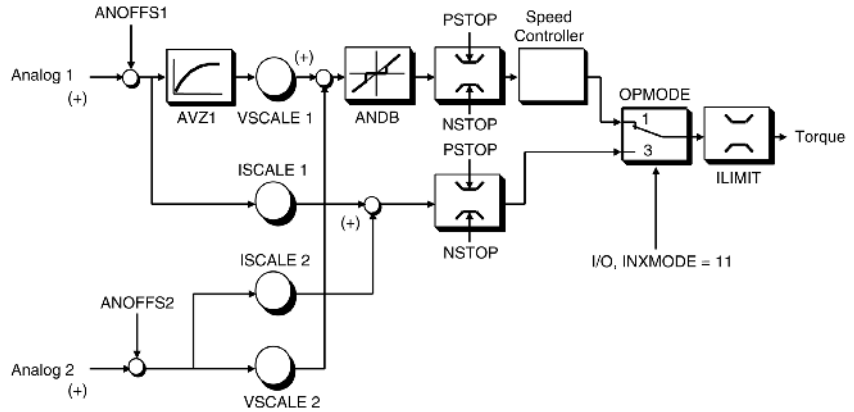

$$X_{\text{command}} = \text{Analog 1} + \text{Analog 2}$$

Selectable by OPMODE or Input

**Note:** Parameter designations correlate to terms used in the UniLink software.

*Continued on next page*

---

## 17D HP Analog Input Loop Diagrams, continued

---

### 17D HP Analog Input Mode 5 Loop Diagram

The following diagram shows an analog input Mode 5 servo loop.

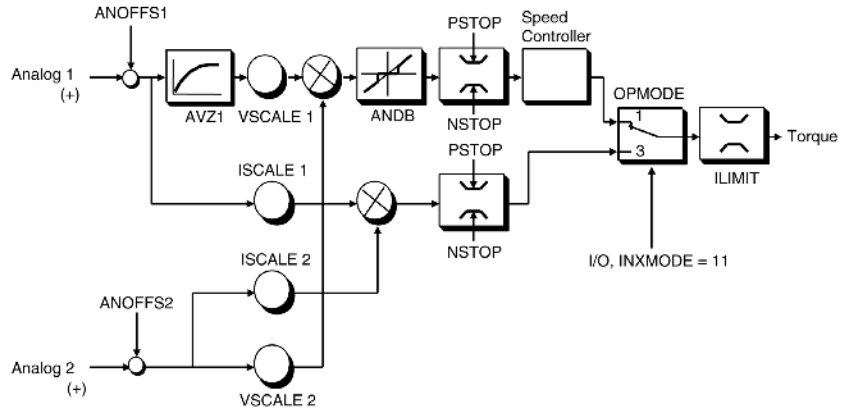

$$X_{\text{command}} = \text{Analog 1} * \text{Analog 2}$$

Selectable by OPMODE or Input

**Note:** Parameter designations correlate to terms used in the UniLink software.

---

# Expansion Options



---

## At a Glance

### What's in this Appendix

This appendix contains the following topics.

Topic	Page
Expansion cards	156
I/O expansion cards	157

---

## Expansion Card

---

### Overview

The Lexium 17D HP drive includes a standard expansion slot (X11) which can be used to increase the functionality of the drive. This slot can accommodate one expansion card. Available expansion cards are a 24 Vdc discrete I/O expansion card and the communication cards FIPIO, MODBUS+, PROFIBUS DP, SERCOS. Each of the communication cards has an user manual.

---

### Fitting expansion card

If you want to fit an expansion card into the Lexium 17D HP, please observe the following:

- Detach the cover from the expansion/option slot. Take care that no small items fall into the open expansion slot.
  - Push the expansion card carefully, and without twisting it, into the guide rails that are provided.
  - Press the expansion card firmly into the slot, until the front cover sits on the fixing lugs. This ensures that the connector has a good contact.
  - Screw the bolts in the front cover into the threaded holes in the fixing lugs.
-

---

## I/O Expansion Cards

---

### **24 Vdc Discrete I/O Expansion Card**

The 24 Vdc discrete I/O Expansion Card (I/O Card AM0INE001V000) increases the available I/O to the drive. With the I/O Card installed, the drive can accommodate an additional 14 discrete inputs and 8 discrete outputs which are fully compatible with Modicon/Telemecanique family of PLCs. The drive must be powered off (both the AC Mains and the 24 Vdc Bias Supply) when the I/O Card is installed. The card is automatically recognized upon power-up of the drive.

---

---

## I/O Expansion Cards, continued

---

### IConnector and LED Location Diagram

The following drawing shows the locations of the Light-Emitting Diodes (LEDs) and the connectors for the I/O Expansion Card.

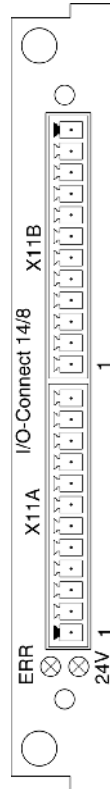

---

### Light-Emitting Diodes (LEDs)

As shown in the diagram above, the two LEDs are mounted next to the terminals on the expansion card. The green LED signals that the 24 Vdc bias supply is available for the expansion card. The red LED signals faults in the outputs from the expansion card (overload of the switching elements, short-circuit).

*Continued on next page*

---

---

## I/O Expansion Cards, continued

---

### Terminal Assignments

The terminal assignments for I/O connector X11A are provided in the following table.

CONNECTOR X11A			
Terminal	Function	Signal Identification	Notes
1	Input	A0	Motion task number $2^0$ (LSB)
2	Input	A1	Motion task number $2^1$
3	Input	A2	Motion task number $2^2$
4	Input	A3	Motion task number $2^3$
5	Input	A4	Motion task number $2^4$
6	Input	A5	Motion task number $2^5$
7	Input	A6	Motion task number $2^6$
8	Input	A7	Motion task number $2^7$ (MSB)
9	Input	Reference	See UniLink online help.
10	Input	Sfault clear	
11	Input	Start MT Next	
12	Input	Start Jog v=x	

---

*Continued on next page*

---

## I/O Expansion Cards, continued

---

### Terminal Assignments, continued

The terminal assignments for I/O connector X11B are provided in the following table.

<b>CONNECTOR X11B</b>			
<b>Terminal</b>	<b>Function</b>	<b>Signal Identification</b>	<b>Notes</b>
1	Input	Motion task restart	See UniLink online help.
2	Input	Start motion task number X	
3	Output	InPos	
4	Output	Next-InPos	
5	Output	Sfault	
6	Output	PosReg1	
7	Output	PosReg2	
8	Output	PosReg3	
9	Output	PosReg4	
10	Output	Not Used	Reserved for future use
11	Power	24 Vdc	Auxiliary supply voltage
12	Power	I/O-Gnd	Digital ground (for controls)

---

---

## I/O Expansion Cards, continued

---

### **Controlling Pre-programmed Motion Tasks**

The additional I/O points provided by the expansion card are used for controlling the execution of pre-programmed, independent motion tasks which can be stored in the drive via the Unilink configuration software. The I/O is used to provide the number of the next internally stored motion task to be executed by the drive and to synchronize the start and finish of these tasks. When connected through this simple discrete I/O interface to a Modicon/Telemecanique PLC, a very cost effective, high functionality single axis positioner can be realized without the expense of purchasing any special external positioning modules.

---

### **Programming the PLC**

As the interface between the drive and the PLC is realized with standard discrete I/O in this configuration, the user is free to program the PLC in any preferred language. The PLC will handle all program flow and branching while the drive will execute the appropriate motion task when commanded by the PLC. Up to 180 separate motion tasks can be stored in the drive's standard non-volatile memory. An additional 75 motion tasks can be stored in the drive's volatile memory at system start-up.

---

### **Motion Task Coordination**

Coordination between the PLC and the drive is achieved through the "In position" output of the drive, the "Start next motion task" input to the drive and the required discrete inputs to the drive corresponding to the binary decoded address of the next motion task to be executed.

---

### **Motion Task Application Examples**

Two examples of motion task applications are as follows:

- If the application under consideration requires configuration and storage of 50 separate motion tasks in the drive, then 6 discrete inputs to the drive must be reserved to uniquely address each task with a 7th discrete input of the drive dedicated to the "Start next motion task" bit and a discrete output of the drive dedicated to the "In position" bit.
- 

*Continued on next page*

---

## I/O Expansion Cards, continued

---

### Motion Task Application Examples, continued

- If the application under consideration requires only 4 separate motion tasks in the drive, then only 2 discrete inputs to the drive need be reserved to uniquely address the stored motion tasks along with the dedicated "In position" and "Start next motion task" bits.



**Note:** A complete description of the operation of the drive's internal positioner and stored motion tasks can be found in the Unilink online help.

---

### Example of a Motion Task Number

An example of a motion task number is provided in the following table.

Motion Task Number								
Decimal	Binary							
	A7	A6	A5	A4	A3	A2	A1	A0
174	1	0	1	0	1	1	1	0

*Continued on next page*

---

# I/O Expansion Cards, continued

## Connection Diagram

The I/O expansion card connections are presented in the following diagram.

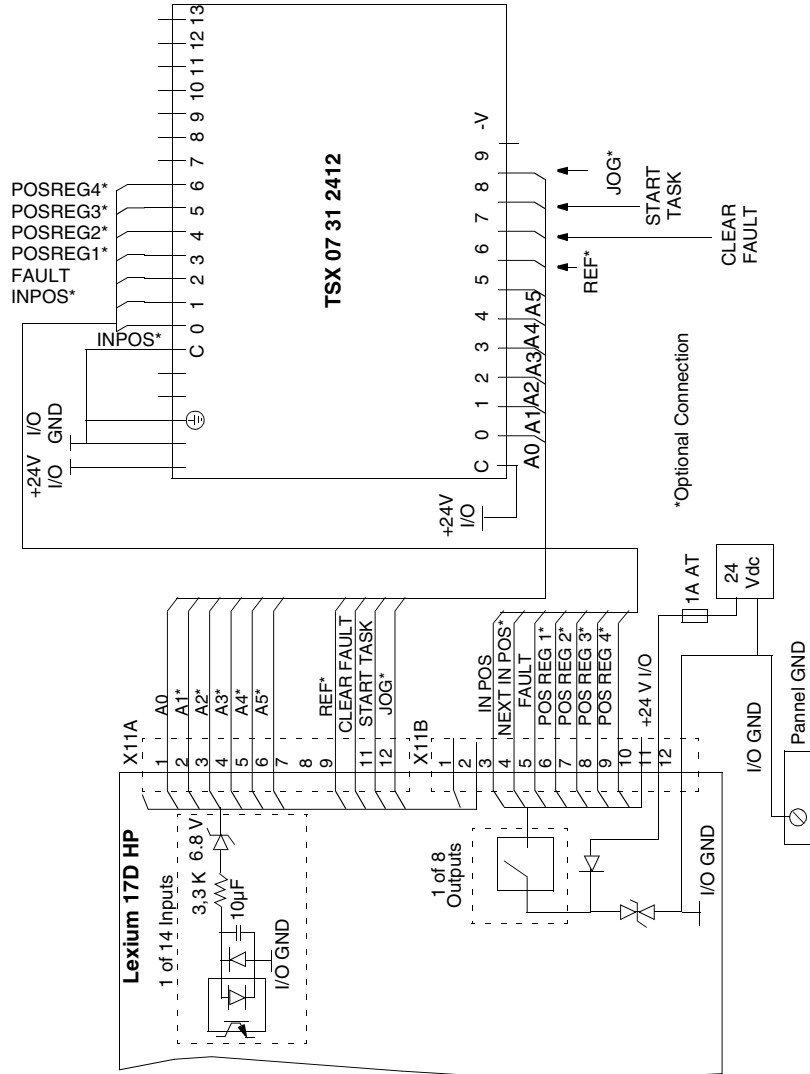

---

---

## External Regen Resistor Sizing



---

### At a Glance

#### What's in this Appendix

This appendix contains descriptions and procedures for calculating the power dissipation requirements for the external Regen resistor.

This appendix presents the following topics.

Topic	Page
Determining external Regen resistor size	167
Example Regen resistor power dissipation calculation	169

---

*Continued on next page*

---

## At a Glance, continued

---

### Overview

When the drive is braking or decelerating a moving load, the kinetic energy of the load must be absorbed by the drive. As the drive decelerates the load, this energy charges the DC link capacitors to successively higher voltages. To prevent damage to the internal electronics, a shunt regulator circuit will apply the Regen resistor across the capacitors when the voltage rises to a set voltage level (determined by the “Mains Voltage” parameter). This dissipates the remaining energy as heat in the Regen resistor. The energy dissipated by the Regen resistor must be calculated in order to determine the proper power rating of the resistor.

---

### Determining When Energy Is Absorbed

To determine when the drive is absorbing energy, examine the motion profile (that is, a graphical plot) of axis speed and torque applied to the motor. Whenever the sign (+ or -) of the torque applied to the motor is opposite that of the speed, the drive is absorbing energy. This typically happens when the drive is decelerating the motor, the motor is controlling tension in a web application, or the motor is lowering a mass in a vertical axis.

---

## Determining External Regen Resistor Size

### Power Dissipation Calculation Procedure

The following is the procedure for calculating the power dissipated by the Regen resistor in a simple system wherein friction is negligible. Ignoring friction in the following calculations gives worst case results since friction will absorb a portion of the energy during deceleration. An example of each step in this procedure is provided later in this chapter.

Step	Action
1	Plot speed versus time and torque versus time for the entire move cycle. (Magnitude of the torque is not required; only the direction is required.)
2	Identify each section of the plot where the drive is decelerating the load or where speed and torque have opposite signs.
3	Calculate the energy returned to the drive in each deceleration using the formula $E = \frac{1}{2} J_t \omega^2$ Where E = Energy in joules $J_t$ = Total system inertia, including motor, in $kg(m^2)$ $\omega$ = Speed at start of deceleration in radians per second ( $\omega = 2 \pi \text{ RPM} / 60$ )
4	Compare the energy in each deceleration with the energy required to turn on the Regen circuit. (See Drive Energy Absorption Capability table.) If the energy is less than that listed in the table, disregard that deceleration for the remainder of the calculations.
5	Calculate the energy dissipated by the Regen resistor by subtracting the energy listed in the table from the energy of the deceleration. $E_{\text{dissipated}} = E_{\text{generated}} - E_{\text{absorbed by capacitors}}$
6	Calculate the pulse power of each deceleration by dividing the dissipated energy by the time of the deceleration. $P_{\text{pulse}} = E_{\text{dissipated}} / T_{\text{decel (seconds)}}$
7	Calculate the continuous power dissipated by the Regen resistor by totaling all the dissipated energy and dividing it by the total cycle time. $P_{\text{continuous}} = (E1_{\text{dissipated}} + E2_{\text{dissipated}} + \dots + EN_{\text{dissipated}}) / T_{\text{total cycle (seconds)}}$

*Continued on next page*

---

## Determining External Regen Resistor Size, continued

---

### Power Dissipation Calculation Procedure, continued

Step	Action
8	An external Regen resistor must be chosen and installed. (See the Parts List appendix for a list of the available external Regen resistors.)

---

### Drive Energy Absorption Capability

The drive energy absorption capability values (in joules) that are needed during the sizing calculations are provided in the following table.

Drive Energy Absorption Capability (joules)				
Line Voltage		230 VAC	400 VAC	480 VAC
Drive Model Number	MHDA1112p00	60	150	180
	MHDA1198p00	120	300	360



**Note:** Multiple drives can be interconnected via the DC-Link. When this is done, the energy absorption capability of the drives and the continuous power ratings of the Regen resistors are additive. The energy absorbed by the drives must be calculated by superimposing all the time speed plots and calculating the energy generated by each axis. (For calculating the power in complex multi-drive applications contact Schneider Electric for assistance.)

---

---

## Example Regen Resistor Power Dissipation Calculation

---

### Example Motor and Drive Specifications

The following is an example application of each step in the power dissipation calculation procedure using the motor, drive and input power specifications identified below. Refer to the power dissipation calculation procedure presented earlier in this chapter.

- Motor = BPH1907p with brake

$$\text{Total Inertia } (J_T) = J_M + J_B + J_L = 0.015 + 0.003 + 0.018 = 0.036 \text{ kgm}^2$$

where:

$$\text{Motor inertia } (J_M) = 0.015 \text{ kg(m}^2\text{)}$$

$$\text{Brake inertia } (J_B) = 0.003 \text{ kg(m}^2\text{)}$$

$$\text{Load inertia } (J_L) = 0.018 \text{ kg(m}^2\text{)}$$

- Drive = MHDA1112p00
- Line Voltage = 480 Vac

---

*Continued on next page*

---

## Example Regen Resistor Power Dissipation Calculation, continued

**Example Step 1** Plot speed versus time and torque versus time for the entire move cycle.

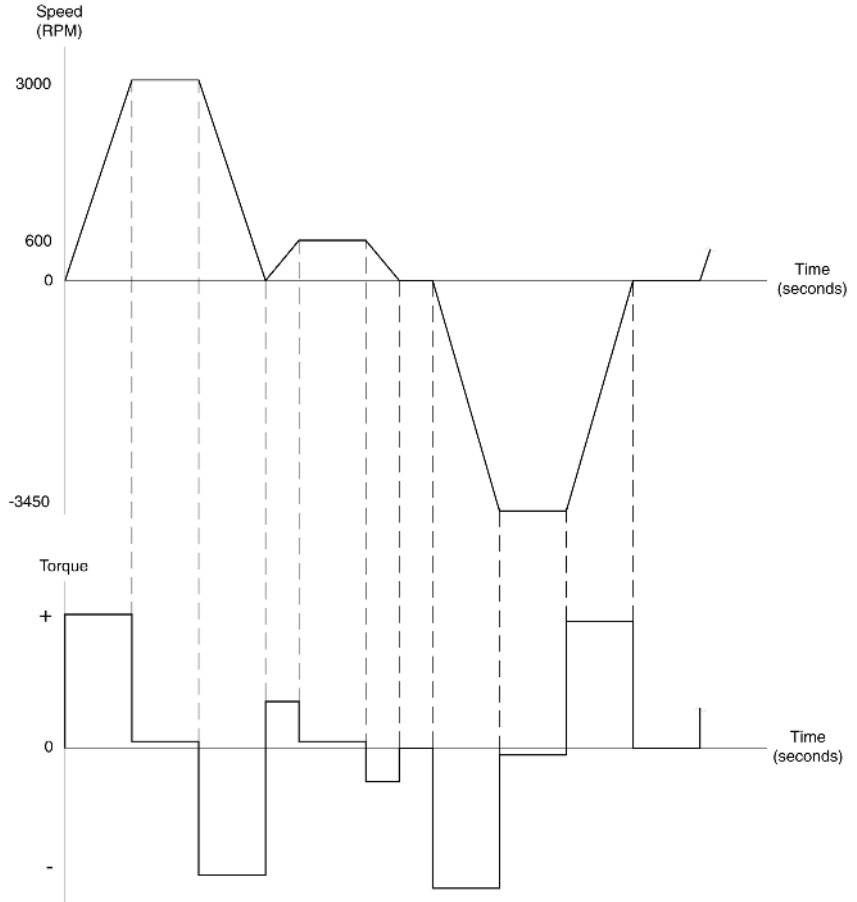

*Continued on next page*

---

## Example Regen Resistor Power Dissipation Calculation, continued

---

**Example Step 2** Identify each deceleration of the plot where the drive is decelerating the load.

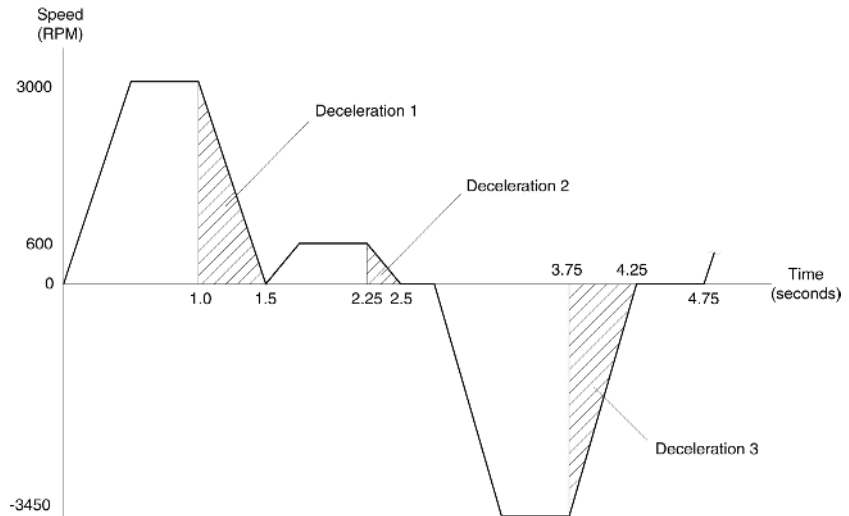

---

**Example Step 3** Calculate the energy returned to the drive in each deceleration as follows:

Deceleration 1

$$\omega = 2 \pi 3000\text{RPM} / 60 = 314 \text{ radians/sec}$$
$$E = \frac{1}{2} 0.036\text{kgm}^2 (314 \text{ radians/sec})^2 = 1775 \text{ joules}$$

Deceleration 2

$$\omega = 2 \pi 600\text{RPM} / 60 = 63 \text{ radians/sec}$$
$$E = \frac{1}{2} 0.036\text{kgm}^2 (63 \text{ radians/sec})^2 = 71 \text{ joules}$$

Deceleration 3

$$\omega = 2 \pi 3450\text{RPM} / 60 = 361 \text{ radians/sec}$$
$$E = \frac{1}{2} 0.036\text{kgm}^2 (361 \text{ radians/sec})^2 = 2347 \text{ joules}$$

---

*Continued on next page*

---

## Example Regen Resistor Power Dissipation Calculation, continued

---

**Example Step 4** Compare the energy in each deceleration with the energy required to turn on the Regen circuit (that is, the energy absorbed by the internal capacitors).

As specified in the Drive Energy Absorption Capability table, the MHDA1112p00 drive at 480 Vac can absorb 180 joules without turning on the Regen resistor circuit.

Deceleration 1: 1775 joules > 180 joules

Deceleration 2: 71 joules < 180 joules (disregard this segment in the remaining steps)

Deceleration 3: 2347 joules > 180 joules

---

**Example Step 5** Calculate dissipated energy as follows:

Deceleration 1:  $E = 1775 - 180 = 1595$  joules

Deceleration 3:  $E = 2347 - 180 = 2167$  joules

---

**Example Step 6** Calculate the pulse power as follows:

Deceleration 1:  $P_{\text{pulse}} = 1595 \text{ joules} / 0.5 \text{ seconds} = 3190$  watts

Deceleration 3:  $P_{\text{pulse}} = 2167 \text{ joules} / 0.5 \text{ seconds} = 4334$  watts

---

**Example Step 7** Calculate continuous power as follows:

$P_{\text{continuous}} = (1595 \text{ joules} + 2167 \text{ joules}) / 4.75 \text{ seconds} = 792$  watts

---

*Continued on next page*

---

## Example Regen Resistor Power Dissipation Calculation, continued

---

**Example Step 8** Compare the ratings as follows:

External Regen resistor ratings of the MHDA1112p00: AM0RFE002V086

$$P_{\text{pulse}} = 45 \text{ kW}$$

$$P_{\text{continuous}} = 860\text{W}$$

Deceleration 1:  $P_{\text{pulse}} = 3190\text{W} < 45 \text{ kW rating}$

Deceleration 2:  $P_{\text{pulse}} = 4334\text{W} < 45 \text{ kW rating}$

$$P_{\text{continuous}} = 792\text{W} < 860\text{W}$$

Power of the Regen resistor is enough.

---

---

# Index

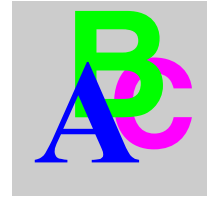

---

## A

- acronyms and abbreviations, 12
- additional safety guidelines, 9
- air flow, 34
- analog
  - I/O connection, 61
  - input mode 0 servo loop, 150
  - input specifications, 117
  - inputs, 61
  - output specifications, 117
  - outputs, 62
- automatic card recognition, 29
- auxiliary encoder interface, 58

## B

- B885-11x
  - control wiring, 138
  - encoder wiring, 139, 140
  - wiring to drive, 138
- B885-11x encoder wiring
  - option 1, 139
  - option 2, 140
- bias input specifications, 107
- bias power, 26
- bias supply, connection, 48
- brake output specifications, 116
- breakout module wiring
  - for Quantum 140 MSx, 137
  - for TSX Premium CAY, 132, 133

## C

- cable separation, 34
- cable shields, connections, 46
- cables
  - parts list, 125
- câbles
  - de sortie codeur, 69
- CAN bus cable, 67
- CANopen interface, 66
- codeur
  - câbles de sortie, 69
- compatible motion modules, 4
- connection to different mains supply networks, 17
- connector and LED location, 158
- control wiring
  - B885-11x, 138
  - MOT 201, 134
  - Quantum 140 MSx, 137
- controlling pre-programmed motion tasks, 161
- current controller servo loop, 148

## D

- DC Link capacitor recharging, 27
- default settings, 29
- determining external regen resistor size, 167
- digital control, 22
- digital inputs and outputs, 63
- dimensions, physical, 44, 47, 48, 49, 50,

51, 52, 53, 54, 55, 56, 57, 59, 61, 62, 63,  
130, 158, 163

discrete

I/O expansion card, 157

input specifications, 115

output specifications, 116

document scope, 1

drive and mounting area dimensions, 36

drive dimensions, 35

drive energy absorption capability, 168

drive implementation, 16

drive models, 16, 122

drive mounting and physical dimensions,  
35

drives available, 16

drives, family, 19

drive-to-motor cables, 125

## E

earth connections, 34

EC directive compliance, 10

electric shock hazards, 6

electrical considerations, 18

electrical specifications, 105, 110

electrical specifications, regen resistor, 111

electrical specifications, signal, 112

electrostatic components precaution, 8

emergency stop strategies, 76

EMI suppression, 26

emulated encoder output (incremental

format) specifications, 113

encoder

emulation, 56

input (slave) specifications, 115

input connection, 55

input specifications, 113

output (incremental format) timing  
diagram, 114

output (SSI format) specifications, 114

output cables, 125

output specifications, 113, 114

wiring for MOT 20x, 135, 136

wiring for Quantum 140 MSx, 137

wiring to B885-11x, 139, 140

environmental and mechanical

specifications, 103

environmental specifications, 103

equipment available, 20

equipment necessary, 20

equipment supplied, 20

error identification and description, 95

error messages, 95

European directives and standards, 10

expansion card, 156

discrete I/O, 157

external 24VDC supply, 124

external fuse specifications, 107

external incremental-encoder, connection,  
59

external regen resistor assembly

dimensions, 37

external regen resistor, connection, 49

external SSI encoder input, 60

## F

fault relay and digital I/O, connection, 63

fault relay output specifications, 116

front panel controls and indicators, 90

## G

general characteristics, 26

grounding, 43

## H

hazards and warnings, 6

## I

I/O expansion card connection, 163

Incremental Encoder Emulation, 58

incremental- encoder output, functional  
description, 56

incremental-encoder output, connection,  
56

installation considerations, 34

installation safety precautions, 32

internal electronics, block diagram, 25

internal power, 27  
internal power dissipation specifications,  
110

## K

keypad operation, 90

## L

LED display, 27, 91  
Lexium 17D HP drives, 122  
Light-Emitting Diodes (LEDs), 158  
Limit supply values with a BPH motor  
brake, 107  
line input specifications, 106

## M

mains choke, 123  
mains choke assembly dimensions, 39  
master-slave operation, 58  
mechanical specifications, 104  
Modbus  
  cables, 125  
models, drive, 16, 122  
MOT 201 control wiring, 134  
MOT 201 encoder wiring  
  option 1, 135  
  option 2, 136  
MOT 20x  
  encoder wiring, 135, 136  
  signal wiring, 134  
moteur  
  au variateur, 68  
motion controller interface, typical  
connections, 130  
motion task applications, 161  
motion task coordination, 161  
motion task number, 162  
motor  
  output specifications, 109  
  overtemperature input specifications,  
  112  
  to drive cables, 125  
motor power connector, 142

mounting dimensions, 36  
multi-axis system, 89

## O

optional mains filters, 127  
output cables, 125  
overcurrent protection, 34  
overview  
  drive models, 16, 122

## P

parameter settings, 89  
parts list  
  cables, 125  
  overview, 121  
  regen resistor assemblies, 126  
  spare parts, 128  
performance specifications, 102  
physical dimensions, 35  
power dissipation calculation, 167  
power electrical specifications, 106  
power supply overcurrent protection, 34  
power wiring, 48  
power-on and power-off characteristics, 74  
Premium CAY  
  single axis drive option, 131  
  single axis wiring, 131  
pre-programmed functions, use, 64  
primary power, 26  
problems, possible causes and corrective  
actions, 99  
products, introduction, 15  
programming the PLC, 161

## Q

qualified personnel, 9  
Quantum 140 MSx control and encoder  
wiring, 137  
Quantum 140 MSx wiring to drive, 137  
quick tuning procedure, 87

## R

- regen circuit functional description, 49
- regen circuit specifications, 111
- regen resistor
  - assembly parts list, 126
- regen resistor power dissipation
  - calculation, example, 169
- regen resistor, determining when energy is absorbed, 166
- regen resistor, overview, 166
- related documents, 5
- resolver input specifications, 112
- resolver, connection, 54
- restart lock
  - advantages, 78
  - application examples, 84
  - AS, 24
  - block diagram, 80
  - connection diagram, 83
  - functional description, 79
  - installation / commissioning, 82
  - signal diagram (sequence), 81
- RS232 interface cable connectors, 146
- RS-232 serial communications cable, 125

## S

- safe electrical separation, 27
- serial communication interface connection, 146
- serial communications specifications, 118
- serial communications, connection, 65
- servo loops
  - analog input mode 0, 150
  - analog input mode 1, 151
  - analog input mode 3, 152
  - analog input mode 4, 153
  - analog input mode 5, 154
  - current controller, 148
  - velocity controller, 149
- servo motor (with brake), connection, 50
- servo motor (with options), connection, 51
- servo motor holding-brake control, 52
- servo motor, rotation direction, 61
- servo motors, types, 16

- setting parameters, 29
- signal wiring, 54
- single-axis motion control system, 4
- software setup, 29
- spare parts table, 128
- specifications
  - analog input, 117
  - analog output, 117
  - bias input, 107
  - brake output, 116
  - discrete input, 115
  - discrete output, 116
  - electrical, 105
  - encoder input, 113
  - encoder output, 113, 114
  - environmental, 103
  - external fuse, 107
  - fault relay output, 116
  - internal power dissipation, 110
  - line input, 106
  - mechanical, 104
  - motor output, 109
  - motor overtemperature, 112
  - power electrical, 106
  - resolver input, 112
- SSI Encoder Emulation, 58
- SSI encoder output, connection, 57
- SSI encoder output, functional description, 57
- stepper motor control, interface
  - connection, 71
- stepper-motor control interface connection, functional description, 71
- stepper-motor control, interface connection diagram, 71
- stepper-motor, speed profile and signal diagram, 72
- stop function, 75
- Sub-D connector wiring diagram, 144
- system configuration, diagram, 21

## T

- terminal assignments, 159
- thermal hazard, 7
- troubleshooting, 99

---

TSX Premium CAY  
breakout module multi-axis wiring, 132  
multi-axis wiring, 133

## U

UL 508C, 11  
UL 840, 11  
UL and cUL compliance, 11  
UniLink commissioning software, 4  
usability enhancements, 23  
usability features, 22  
user guide organization, 2

## V

velocity servo loop, 149  
verifying system operation, 86

## W

warning identification and description, 94  
warning messages, 94  
who should use this guide, 2  
wire specifications, 119  
wiring  
connections, 44  
drive to B885-11x, 138  
drive to MOT 201, 134  
drive to Quantum 140 MSx, 137  
drive to TSX Premium CAY, 131  
wiring and I/O, initial considerations, 43  
Wiring the feedback connector of the BPH  
motors, 145  
wiring the Sub-D connector, 143

